

Assembly, installation and maintenance manual

Montage-, Aufbau- und Wartungsanleitung • Assemblage, manuel de montage et d'entretien • Montaje, instalación y mantenimiento • Manuale di montaggio, installazione e manutenzione • Monterings- og vedlikeholdsmanual • Monterings-, installations- och underhållsmanual • Kokoamis-, asennus- ja huolto-ohje • Vejledning for montering og vedligehold • Handleiding voor montage, installatie en onderhoud • Manual de montagem, instalação e manutenção • Návod k montáži, instalaci a údržbě • Instrukcja montażu, instalacji i konserwacji • Surinkimo, montavimo ir priežiūros vadovas • Montāžas, uzstādīšanas un apkopes rokasgrāmata • Руководство по сборке и обслуживанию • Montaaži-, paigaldus- ja säilitamise juhend



Sauna **FR44-2323**

<p>Factory inspection by • Werkskontrolle durch • Contrôle à partir de l'usine par • Inspector de fábrica • Collaudato da • Fabrikkontroll utført av • Fabriksbesiktigat av • Tehtaan tarkastaja • Fabriks Kontrol udført af • Fabriekscontrole door • Inspeção de fábrica, por: • Zkontrolováno ve výrobním závodě • Kontrola fabryczna do • Apžiūrą gamykloje atliko • Rūpnīcas pārbaudi veicis • Заводской контроль • Tehase kontroll teostatud:</p> <p>.....</p>	<p>Date • Datum • Date • Fecha • Data • Dato • Datum • Päiväys • Dato • Datum • Data • Datum • Data • Datums • Data • Дата • Kuupäev:</p>
	<p>Pack number • Pack Nr. • Packet n° • Bulto N° • Pacco N. • Serienr • Produktionsnummer • Pakettinro • Pakke nr. • Pak nr. • Número de embalagem • Číslo balení • Numer opakowania • Pakuotės numeris • Iepakojuma numurs • Упаковочный номер • Pakinumber:</p>



www.palmako.ee/information-hub

English: Before installing and using the product, please read the instructions and warranty terms at www.palmako.ee/information-hub to guarantee proper installation and long-lasting performance.

Deutsch: Wichtig! Bitte vor Aufbau und Nutzung des Produkts unbedingt die detaillierte Montageanleitung sowie die Garantiebedingungen unter www.palmako.ee/information-hub lesen, um eine fachgerechte Montage und eine lange Funktionssicherheit zu gewährleisten.

Français: Avant d'installer et d'utiliser le produit, veuillez lire les instructions et les conditions de garantie sur www.palmako.ee/information-hub afin de garantir une installation correcte et la longévité du produit.

Español: Antes de instalar y utilizar el producto, lea las instrucciones y las condiciones de garantía en www.palmako.ee/information-hub para asegurar una instalación correcta y una larga vida útil del producto.

Italiano: Prima di installare e utilizzare il prodotto, leggere le istruzioni e le condizioni di garanzia su www.palmako.ee/information-hub per garantire una corretta installazione e prestazioni durature.

Norsk: Før montering og bruk av produktet, vennligst les monteringsanvisningene og garantivilkårene på www.palmako.ee/information-hub for å sikre korrekt montering og fremtidig holdbarhet.

Svenska: Innan du installerar och använder produkten, vänligen läs instruktionerna och garantivillkoren på www.palmako.ee/information-hub för att säkerställa korrekt installation och produktens långvariga hållbarhet

Suomi: Ennen tuotteen asentamista ja käyttämistä, lue ohjeet ja takuehdot osoitteessa www.palmako.ee/information-hub varmistaaksesi oikean asennuksen ja pitkäkestoisen toiminnan.

Русский: Перед установкой и использованием изделия ознакомьтесь с инструкцией и условиями гарантии на сайте www.palmako.ee/information-hub, чтобы гарантировать правильную установку и долговечность изделия.

Eesti: Enne toote paigaldamist ja kasutuselevõttu lugege palun juhiseid ja garantiitingimusi aadressil www.palmako.ee/information-hub, et tagada nõuetekohane paigaldus ja toote pikk eluiga.

Dansk (Oversat af AI): Læs venligst instruktionerne og garantibetingelserne på www.palmako.ee/information-hub, før du installerer og bruger produktet, for at garantere korrekt installation og langvarig ydeevne.

Dutch (Vertaald door AI): Lees vóór de installatie en het gebruik van het product de instructies en garantievoorwaarden op www.palmako.ee/information-hub om een correcte installatie en langdurige werking te garanderen

Português (Traduzido por IA): Antes de instalar e utilizar o produto, leia as instruções e os termos de garantia em www.palmako.ee/information-hub para garantir uma instalação adequada e um desempenho duradouro.

Čeština (Přeloženo umělou inteligencí): Před instalací a použitím produktu si prosím přečtěte pokyny a záruční podmínky na www.palmako.ee/information-hub, abyste zaručili správnou instalaci a dlouhodobý výkon.

Polski (Przetłumaczone przez AI): Przed zainstalowaniem i użyciem produktu należy przeczytać instrukcję oraz warunki gwarancji dostępne na stronie www.palmako.ee/information-hub, co pozwoli zagwarantować prawidłową instalację i długotrwałą wydajność.

Latviešu (Mākslīgā intelekta tulkojums): Pirms produkta uzstādīšanas un lietošanas, lūdzu, izlasiet instrukcijas un garantijas noteikumus vietnē www.palmako.ee/information-hub, lai garantētu pareizu uzstādīšanu un ilgstošu darbību.

Lietuviškai (Išvertė DI): Prieš montuodami ir naudodami gaminį, perskaitykite instrukcijas ir garantijos sąlygas adresu www.palmako.ee/information-hub, kad užtikrintumėte tinkamą montavimą ir ilgalaikį veikimą.

210 102

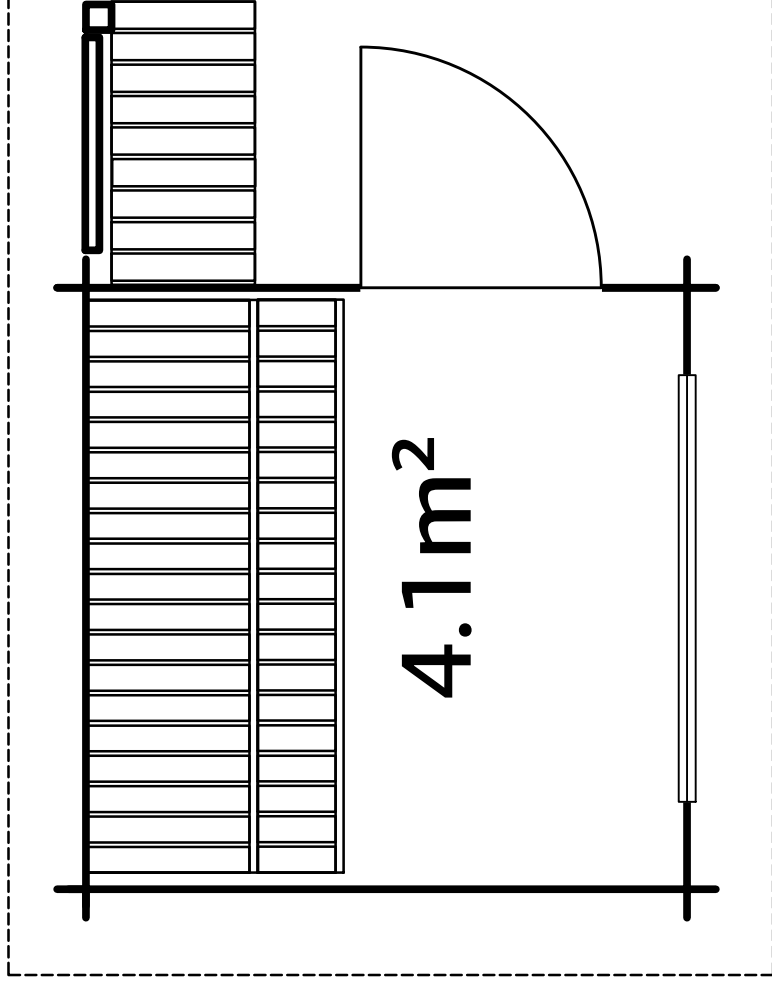









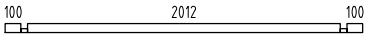
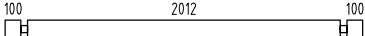

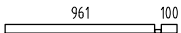

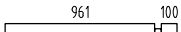
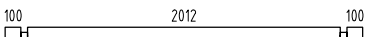

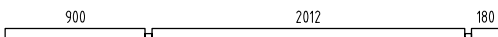
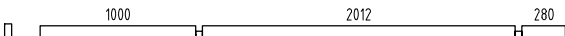
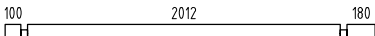

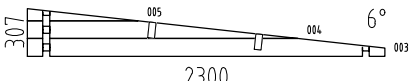
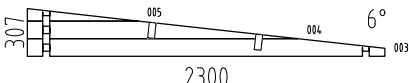

210



267

342



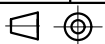





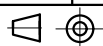



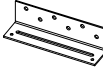









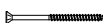



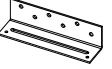

4.1m²

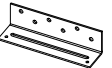
Pos	SPECIFICATION-STÜCKLISTE-NOMENCLATURE-ELEMENTI-ESPECIFICACIÓN FR44-2323	Pcs	Profile (mm)	Length (mm)
001		1	44x57	2300
002		45	44x114	2300
006		1	44x57	350
007		1	44x57	1105
008		17	44x114	350
009		17	44x114	1105
010		1	44x114	2300
011		18	44x114	400
012		1	44x114	3180
013		1	44x120	3380
014		1	44x114	2380
015		1	44x120	3380
W1-1		1		
W2-1		1		
AR1	Foundation- Fundament- Fondation- Fondazione- Vigas de cimentación 	2	70x45	2090
AR2	Foundation- Fundament- Fondation- Fondazione- Vigas de cimentación 	5	70x45	1950
FB1	Floor board- Fussbodenbrett- Madrier du plancher - Tavola pavimento- Tabla de suelo 	17	120x28	2006
Pst1	Post- Pfosten- Poteau- Montante- Poste 	1	45x70	405
Pst2	Post- Pfosten- Poteau- Montante- Poste 	1	90x90	2120
Sla1	Slat- Leiste- Baguette- Listello- Listón 	6	19x19	2010
Sla3	Slat- Leiste- Baguette- Listello- Listón 	1	28x45	845
SP1	Support brace- Stützleiste- Baguette de support- Listello di supporto- Listón de soporte 	2	34x70	2010
SP2	Support brace- Stützleiste- Baguette de support- Listello di supporto- Listón de soporte 	1	58x40	470

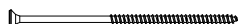



Pos	SPECIFICATION-STÜCKLISTE-NOMENCLATURE-ELEMENTI-ESPECIFICACIÓN FR44-2323	Pcs	Profile (mm)	Length (mm)
SP3	Support brace- Stützleiste- Baguette de support- Listello di supporto- Listón de soporte 	2	58x40	370
SP4	Support brace- Stützleiste- Baguette de support- Listello di supporto- Listón de soporte 	2	58x40	570
PR1	Purlin- Dachpfette- Arbalétrier- Arcareccio- Correa 	2	44x120	3380
RB2-1	Roof board- Dachbrett- Madrier du toit- Tavola tetto- Tabla de tejado 	38	89x19	2640
CB1-1	Ceiling board- Dachbodenbrett- Madrier du Grenier- Tavola soffitta- Tabla de techo 	23	89x16	2018
EaE6-1	Eave edging- Dachrandbrett- Madrier en bordure du toit- Tavola bordo tetto- Tabla de valadizo 	2	19x120	2740
EaE6-2	Eave edging- Dachrandbrett- Madrier en bordure du toit- Tavola bordo tetto- Tabla de valadizo 	2	19x120	3480
FIB2-1	Floor beading- Fussbodenleiste- Baguette du plancher- Listello pavimento- Listón de suelo 	4	19x19	2040
CeS1-1	Ceiling slat- Deckenleiste- Baguette du plafond- Listello tetto- Listón de techo 19x19 	4	19x19	2040
RE2-1	Roof edge reinforcement- Dachrandleiste- Baguette en bordure du toit- Rinforzo bordo tetto- Refuerzo borde tejado 	2	32x40	3380
Sis1-1	Side slat- Randleiste- Baguette en bordure- Listón de borde- Listello bordo 	4	19x70	1150
Sis1-2	Side slat- Randleiste- Baguette en bordure- Listón de borde- Listello bordo 	1	19x70	1600
Sis1-3	Side slat- Randleiste- Baguette en bordure- Listón de borde- Listello bordo 	4	19x70	2050
Sis2-1	Side slat- Randleiste- Baguette en bordure- Listón de borde- Listello bordo 	2	19x95	1050
Sis2-2	Side slat- Randleiste- Baguette en bordure- Listón de borde- Listello bordo 	3	19x95	1750
StB1-1	Storm brace- Sturmleiste- Protection contre le vent- Antivento- Protector contra tormentas 	2	25x45	2060
StB1-2	Storm brace- Sturmleiste- Protection contre le vent- Antivento- Protector contra tormentas 	2	25x45	2250
WG1-1	Water gutter- Wasserleiste- Rejet d'eau- Protección de lluvia- Protezione dalla pioggia 	1	19x33	1050
WB1-1	Wind brace- Windbrett- Madrier contre le vent- Tavola vento- Tabla contra el viento 	2	16x45	2740
Fim	-Fixing kit- Befestigungsset- Moyens de fixation- Materiale di fissaggio- Kit de fijación	1	USE	
QLA16	Adjustment bolt - Senkbolzen - Boulon de réglage - Bullone di regolamento- Perno de ajuste 	1	Pst2	
QRT30 x10x50	Adjustment bolt - Senkbolzen - Boulon de réglage - Bullone di regolamento- Perno de ajuste 30xM10x50 	1	Pst1	
QTE 50AL	Aluminium tape - Aluminiumband- Ruban d'aluminium- Nastro di alluminio- Cinta de aluminio- QTE50AL 	1	MMPI30x 600x1200	
QPOYP8 x100Zn	Bolt -Schloss-schraube -Boulon- Bullone- Perno- M8x100mm PUP0 	1	Pst2	
QPOYP 8x80Zn	Bolt -Schloss-schraube -Boulon- Bullone- Perno- M8x80mm PUP0 	9	StB1-1 StB1-2	

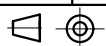

Pos	SPECIFICATION-STÜCKLISTE-NOMENCLATURE-ELEMENTI-ESPECIFICACIÓN FR44-2323	Pcs	Profile (mm)	Length (mm)
QULSI3 0x40-2	Cylinder- Zylinderschloss- Serrure a mortaiser- Serratura a cilindro- Bombin- 30.40-2		1	U44-100P
QLIU3 5x92Hb	Door fittings- Türbeschlag- Ferrure- Ferramenta porta- Manilla (puerta)- QLIU35x92Hb		1	U44-100P
QNU35x3 5x130Zn	L-iron- Winkel- Angle -Angolo- Angulo 35x35x130 EM VN353590		3	Louvre
QNA1 4x40Me	Nail- Nagel- Clou- Chiodo- Clavo- 1.4x40mm		100	
QNA2 2x50Zn	Nail- Nagel- Clou- Chiodo- Clavo- 2.5x50mm		170	RB2-1 CB1-1
QMUk K8Zn	Nut- Schraubenmutter- Écrou- Dado- Tuerca- M8mm		9	
QKRPP3 _5x40Zn	Screw- Schraube- Vis- Vite- Tornillo- 3.5x40mm		41	 ; Sla1
QKRPP 3x20Zn	Screw- Schraube- Vis- Vite- Tornillo- 3x20mm		12	
QKRPP 4_2x6 5HATX	Screw- Schraube- Vis- Vite- Tornillo- 4.2x65mm		170	FB1 ; FB2
QKRPP4 _5x50Zn	Screw- Schraube- Vis- Vite- Tornillo- 4.5x50mm		166	EaE6-x;WB1-x;RE2-x EL3; Sisx-x
QKRPP4 _5x60Zn	Screw- Schraube- Vis- Vite- Tornillo- 4.5x60mm		2	CoB1
QKRPP4 _5x70Zn	Screw- Schraube- Vis- Vite- Tornillo- 4.5x70mm		50	 SP2; SP3; SP4 001; 007; 006 013; 015; SP6; SP7
QKRPP 4x16Zn	Screw- Schraube- Vis- Vite- Tornillo- 4x16mm		18	
QKRYP5 x40ZnTX	Screw- Schraube- Vis- Vite- Tornillo- 5x40mm		3	
QKRPP5 x80ZnTX	Screw- Schraube- Vis- Vite- Tornillo- 5x80mm		20	SP2; SP3; SP4 EL1a ; EL1b
QKRPP 5x90Zn	Screw- Schraube- Vis- Vite- Tornillo- 5x90mm		33	Wx-1 ; PR1x CnB1
QKRPP6 x150Zn	Screw- Schraube- Vis- Vite- Tornillo- 6x150mm		10	AR2
QKA1 00ANT	Ventilation grate- Lüftungsdeckel- Couvercle d'aération- Copertura aerazione- Embelcedor ventilación QKA100ANT		3	Wall1 ; WallB
QTU-2	Ventilation grate- Lüftungsdeckel- Couvercle d'aération- Copertura aerazione- Embelcedor ventilación QTU-2		1	WallB
QSE8 x22Zn	Washer- Dichtscheibe- Joint- Rondella- Arandela- 8x22mm		9	
QMUL G10Zn	Captive nut- Einschlagmutter- Écrou a griffes- Dado a ragno filettatura- Tuerca arana- LM10		1	
MMPI30x 600x1200	Finnfoam FF-PIR 30 SAUNA 30x600x1200mm		8	

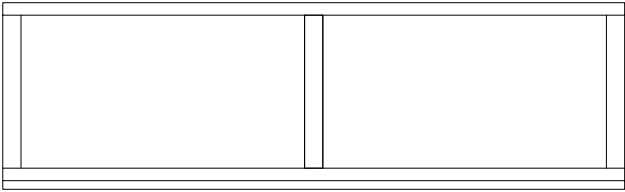
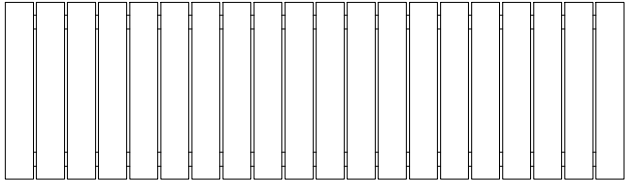
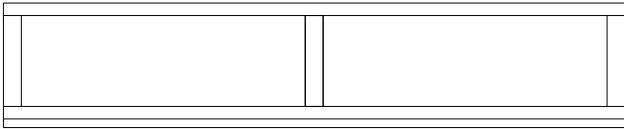
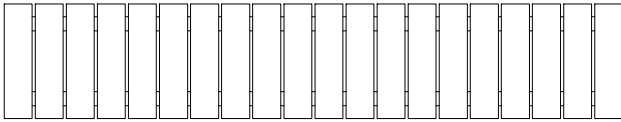

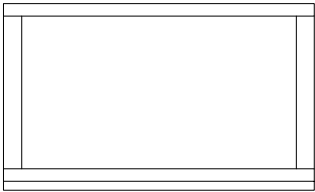
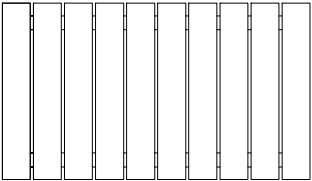
Pos	SPECIFICATION-STÜCKLISTE-NOMENCLATURE-ELEMENTI-ESPECIFICACIÓN FR44-2323	Pcs	Profile (mm)	Length (mm)
EL1a		1	600x90	2000
EL1b		1	568x47	1990
EL2a		1	400x90	2000
EL2b		1	368x47	1990
EL3		1	320x47	1900
EL4a		1	500x90	1000
EL4b		1	468x47	990

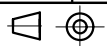

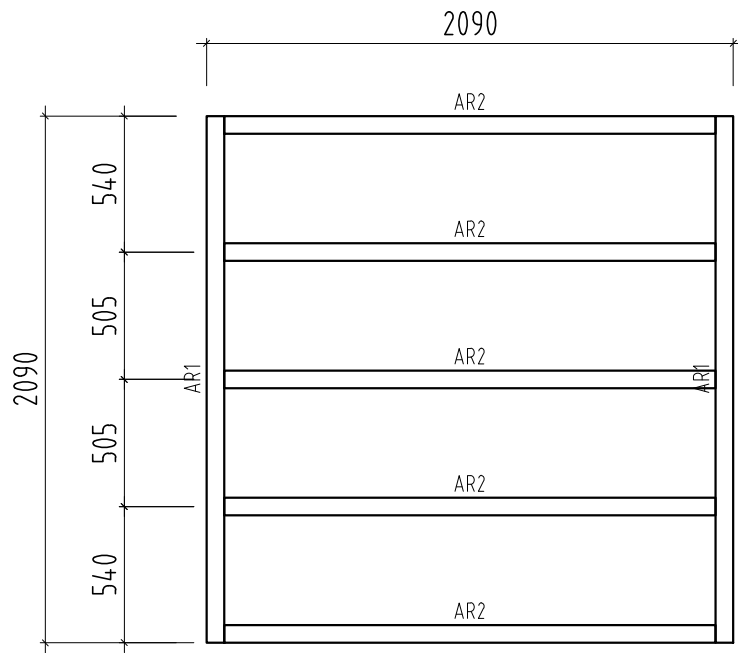

H = 1.700 m
TOTAL: 4.05 m²

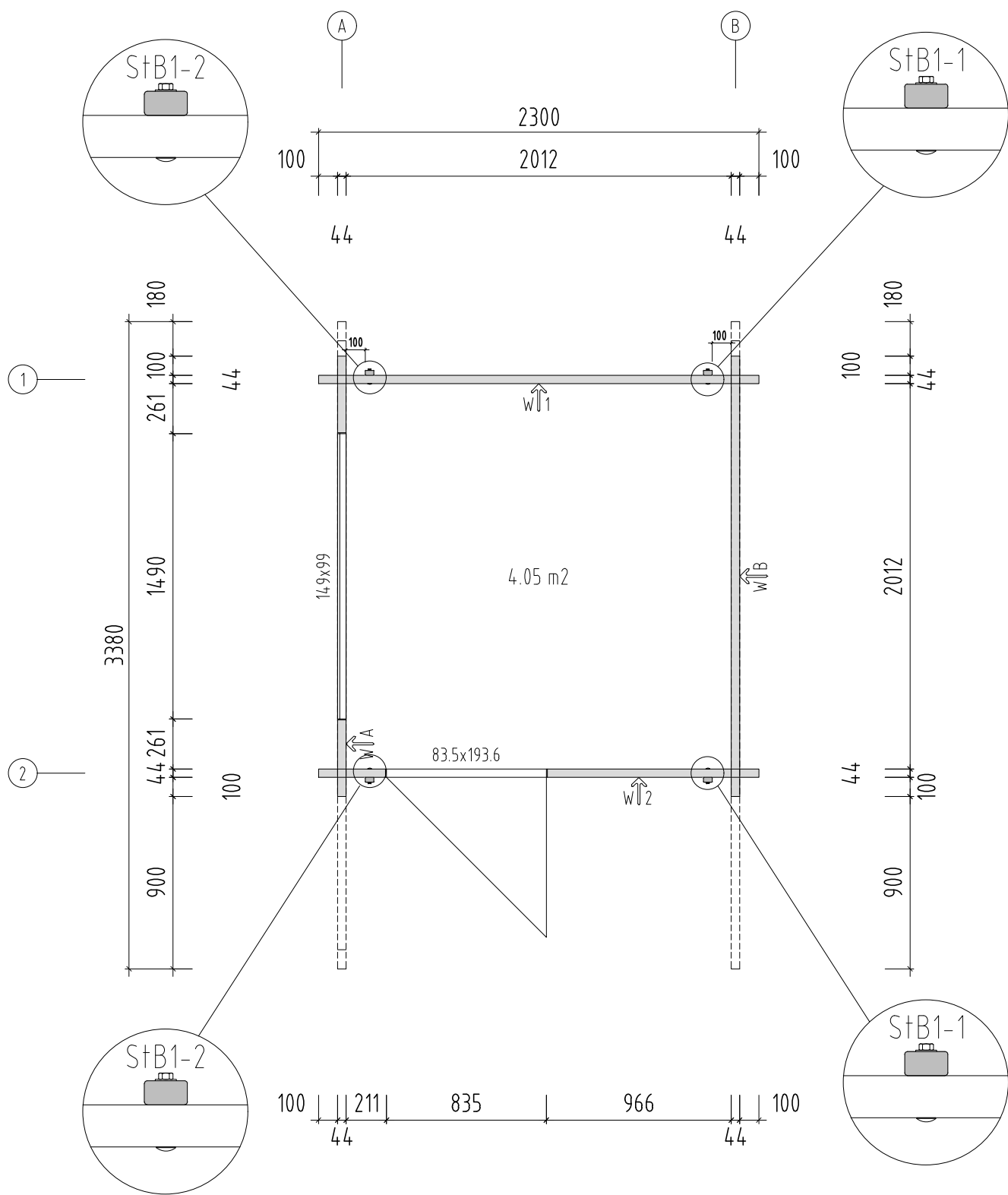

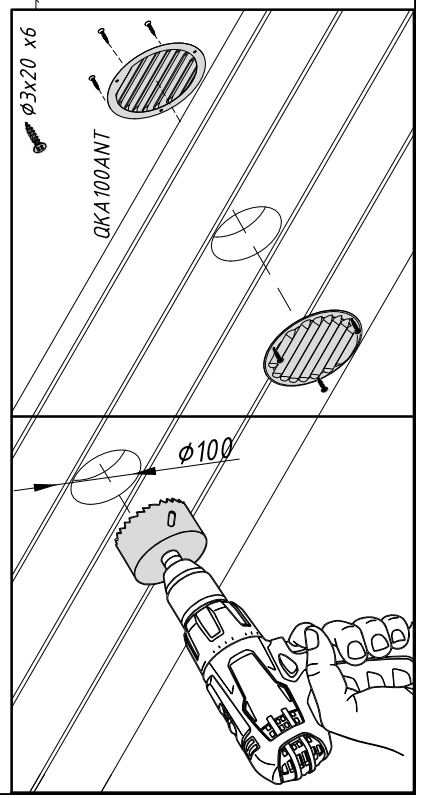
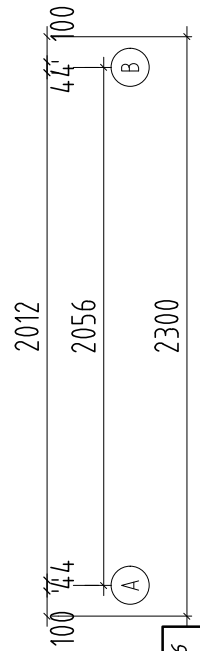
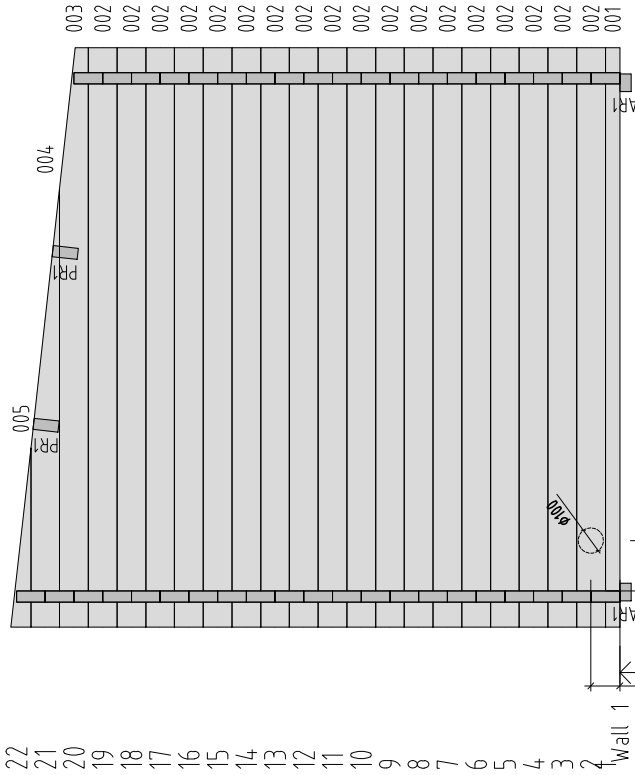
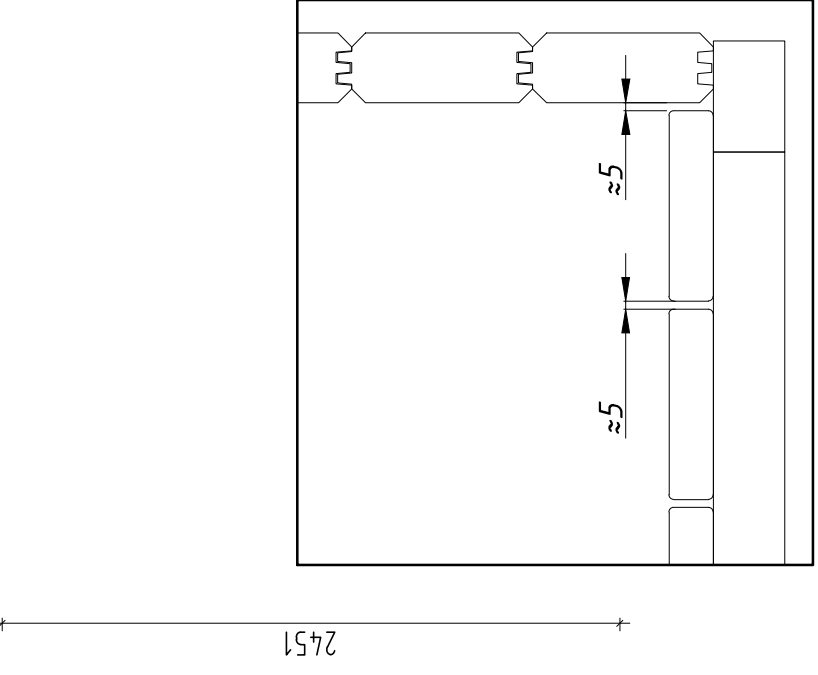

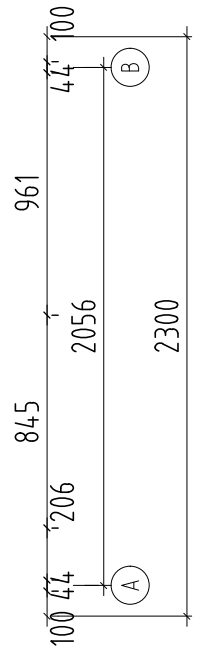
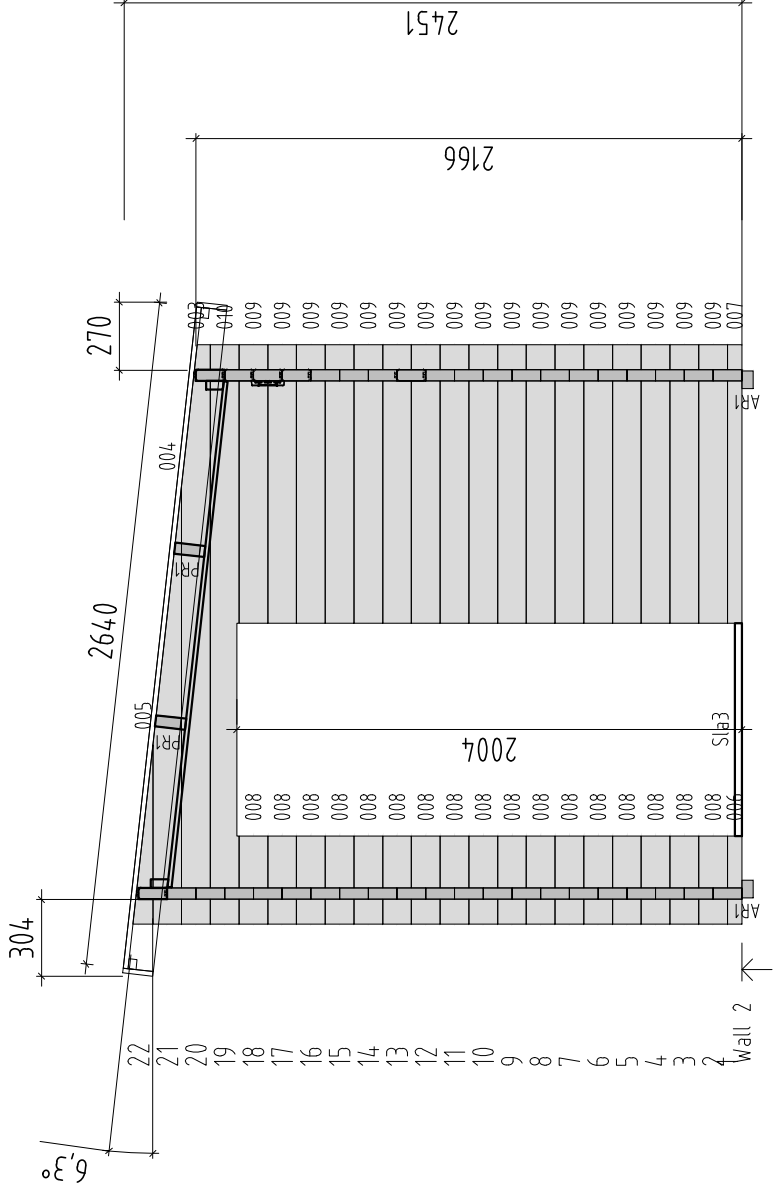

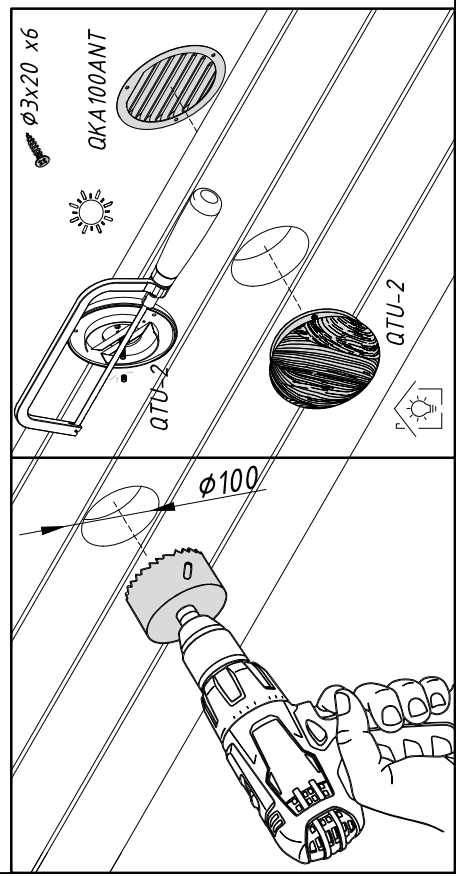
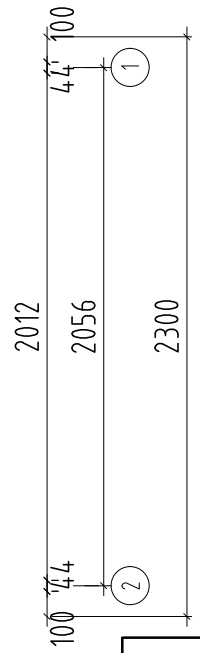
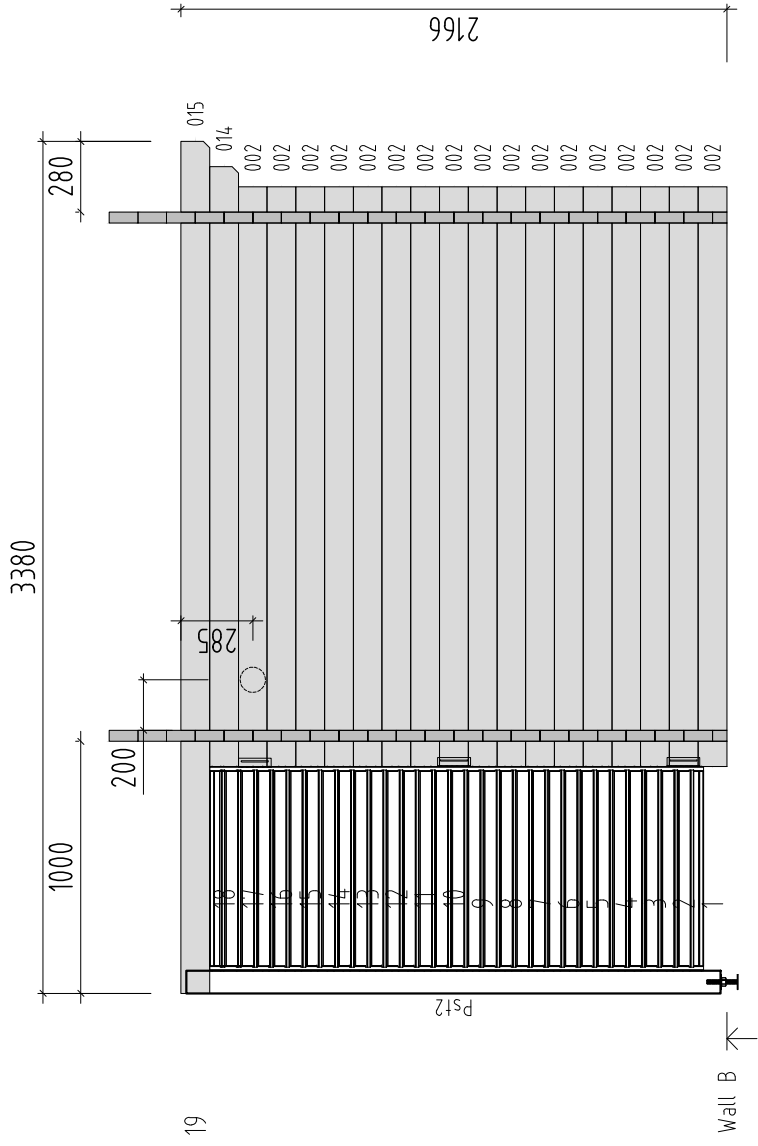

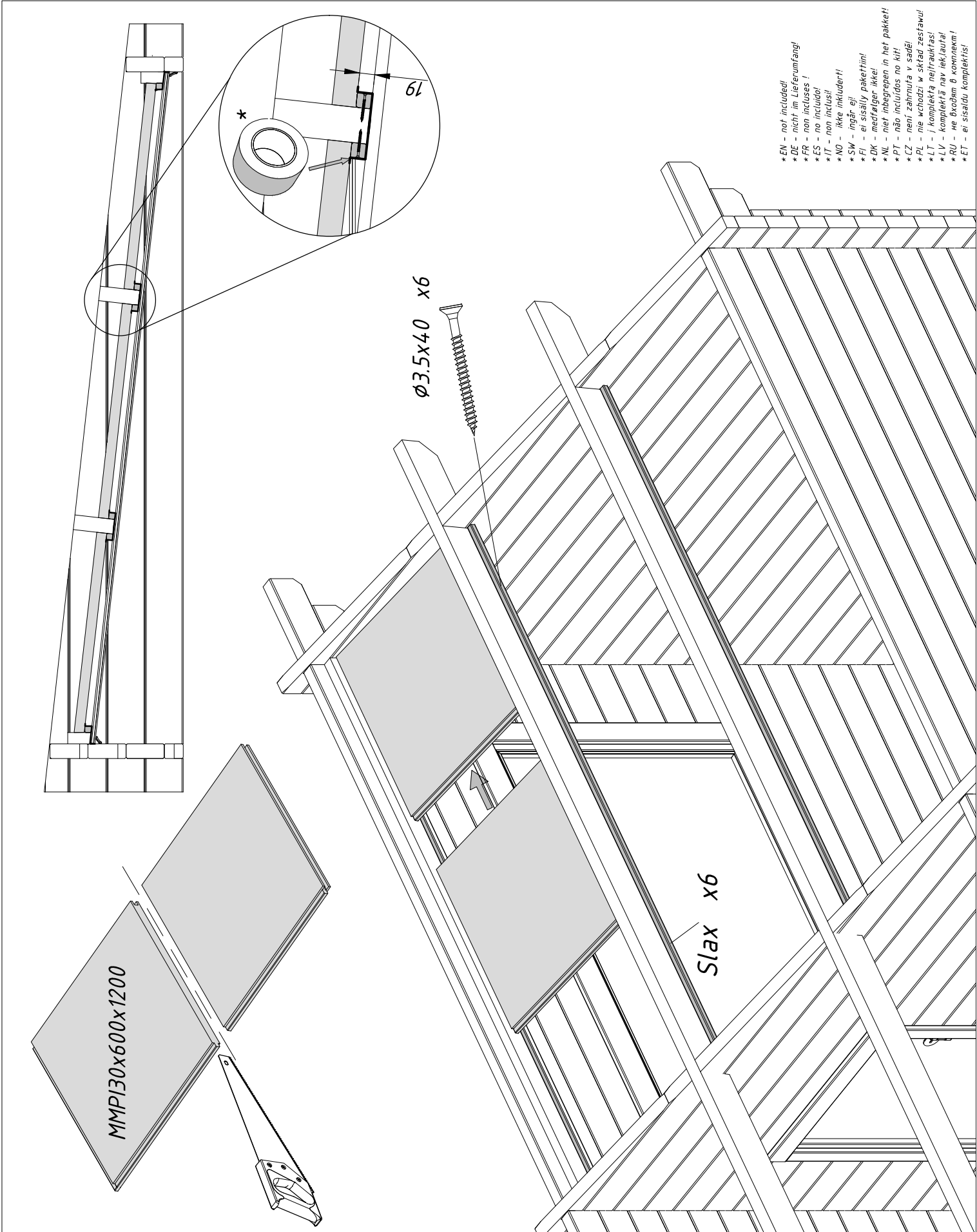

MMPI30x600x1200

Ø3.5x40 x6

Slax x6

- *EN - not included!
- *DE - nicht im Lieferumfang!
- *FR - non inclusés !
- *ES - no included!
- *IT - non inclusi!
- *NO - ikke inkludert!
- *SW - ingår ej!
- *FI - ei sisälly pakettiin!
- *DK - medfølger ikke!
- *NL - niet inbegrepen in het pakket!
- *PT - não incluídos no kit!
- *CZ - není zahrnuta v sadě!
- *PL - nie wchodzi w skład zestawu!
- *LT - į komplektą neįtrauktas!
- *LV - komplektā nav iekļauti!
- *RU - Не входит в комплект!
- *ET - ei sisaldu kompleksis!

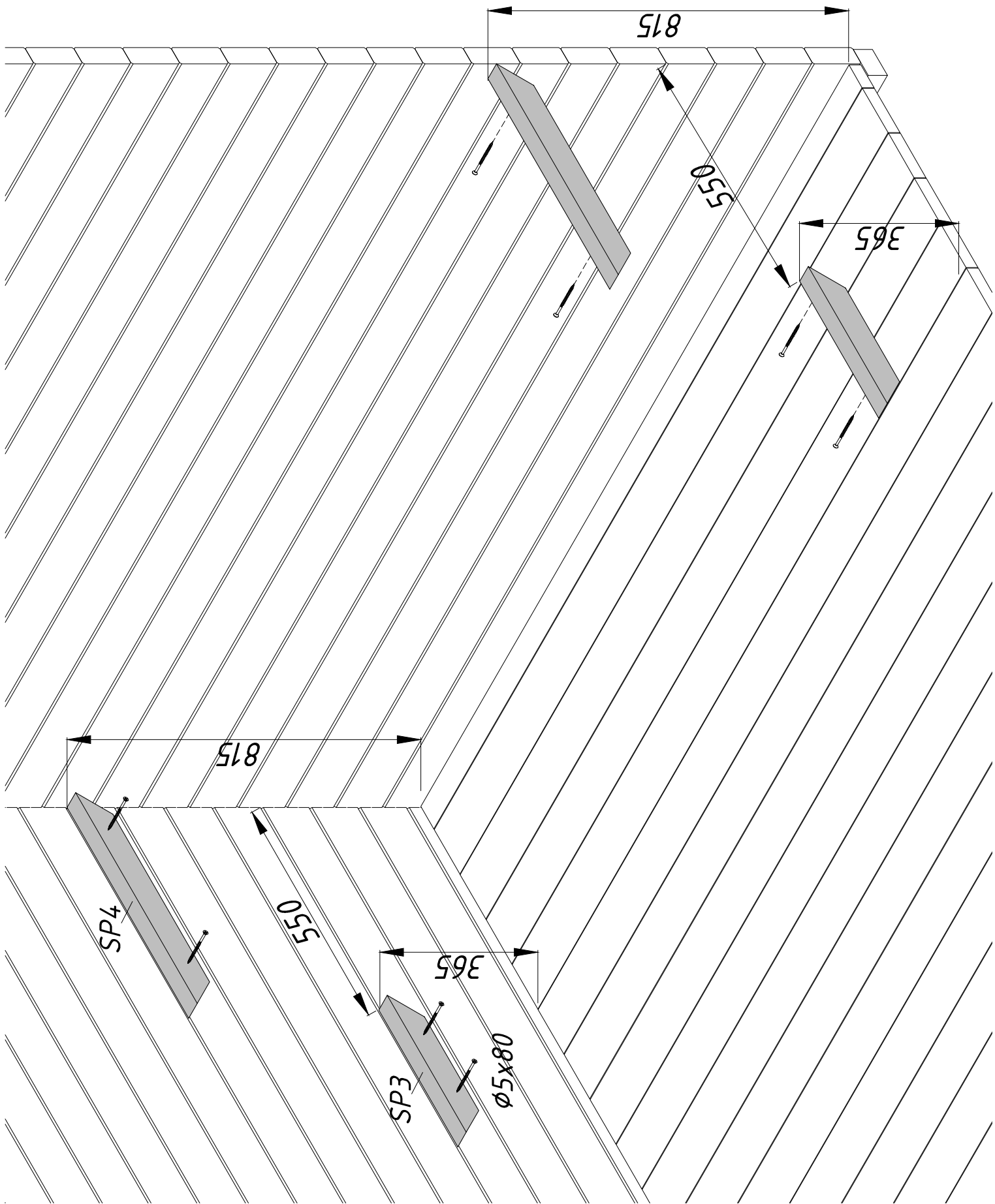

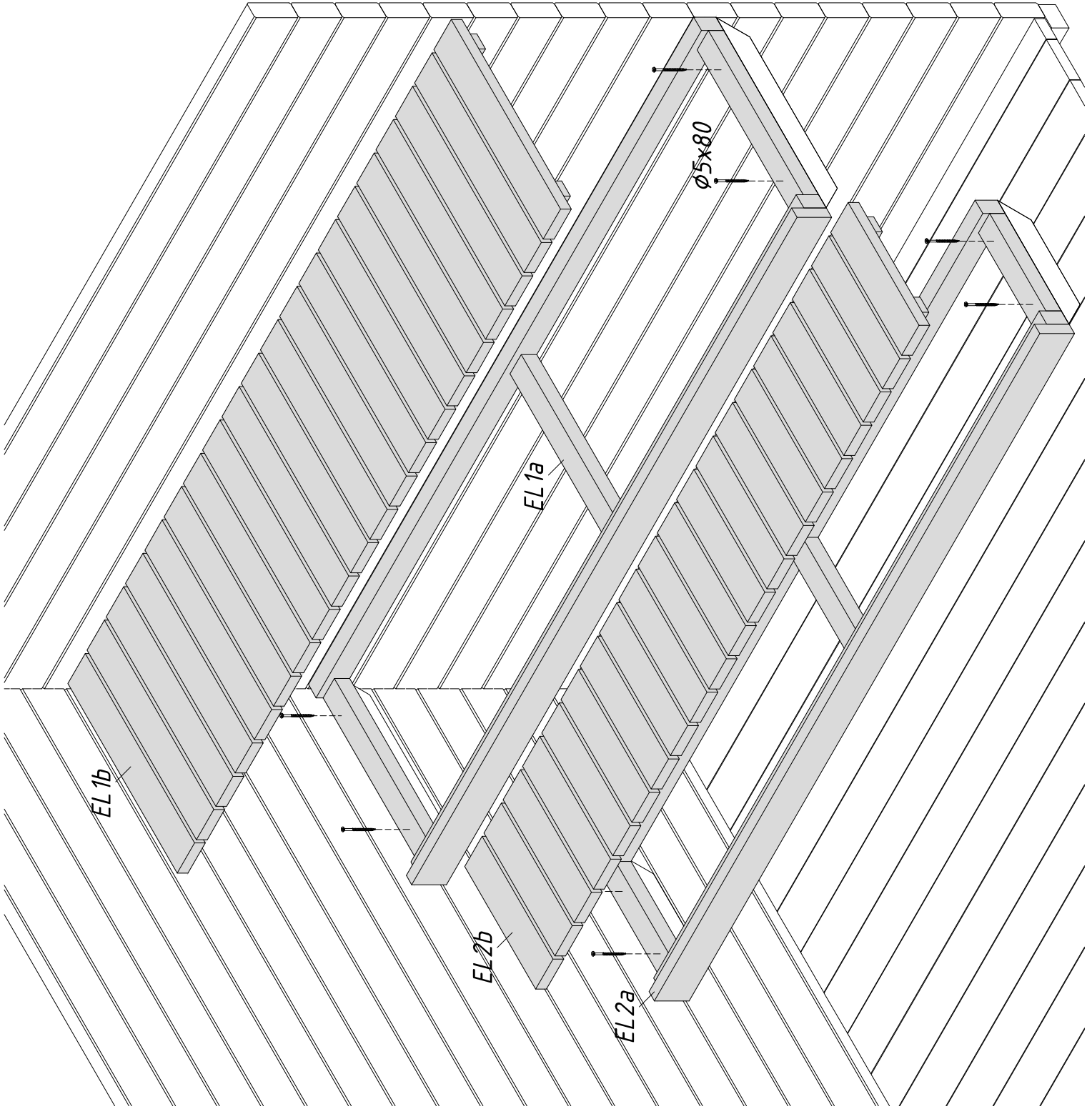

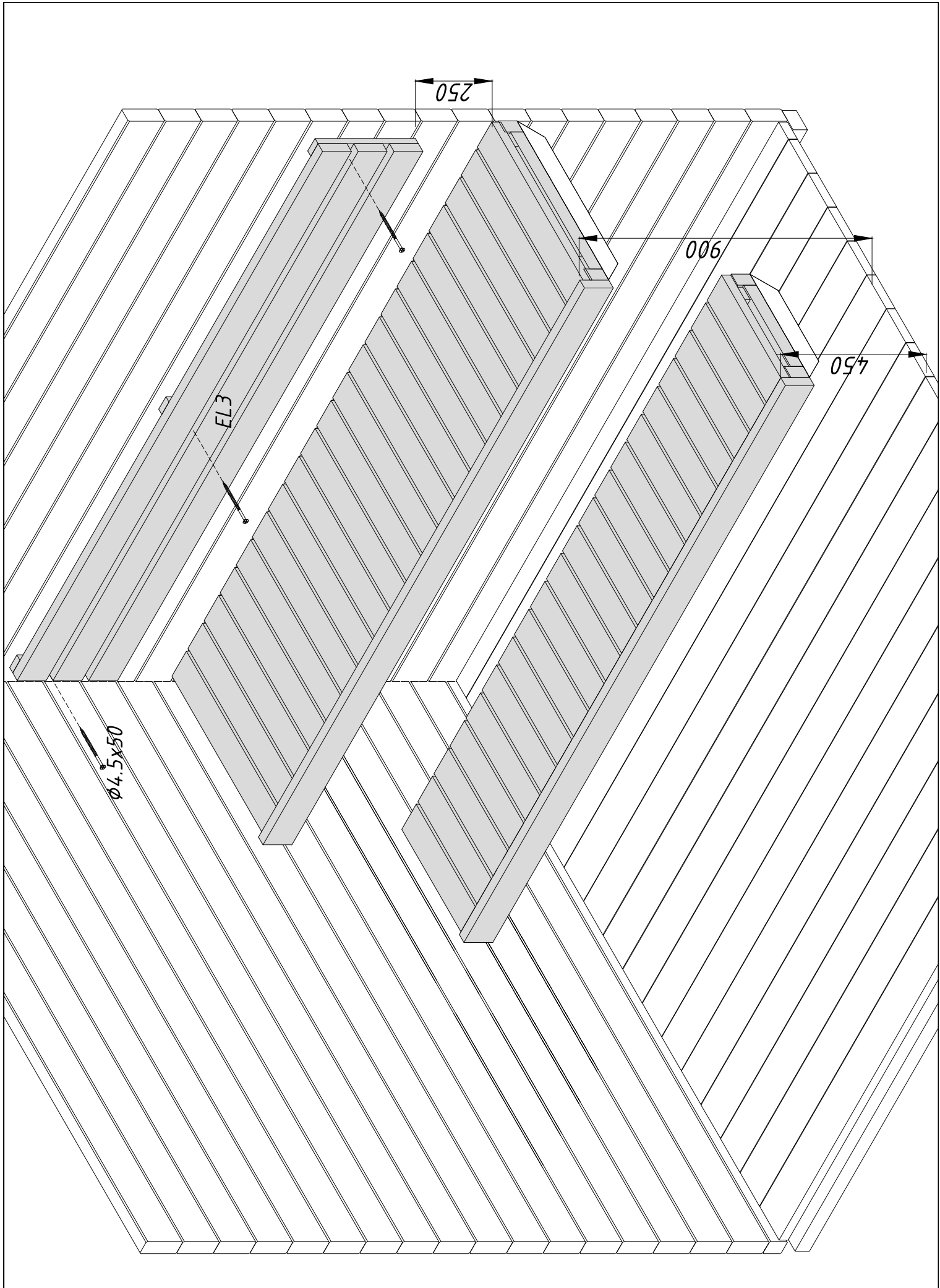

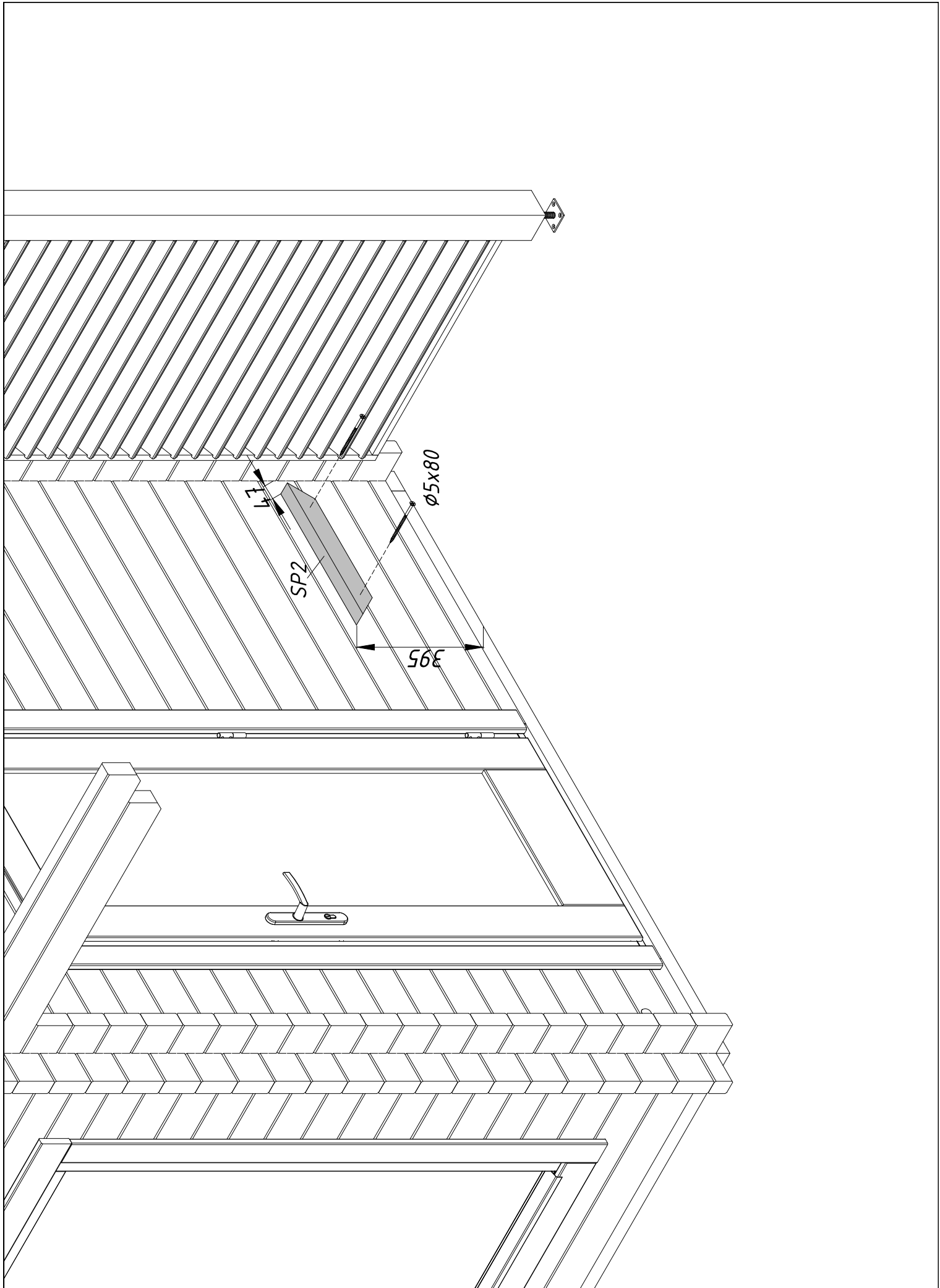

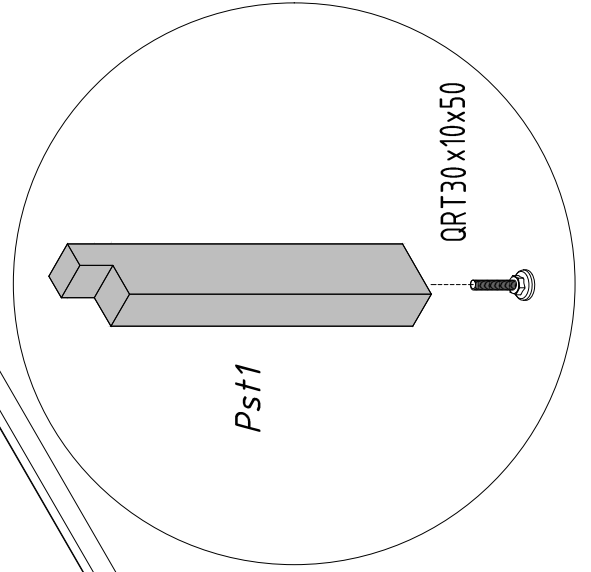
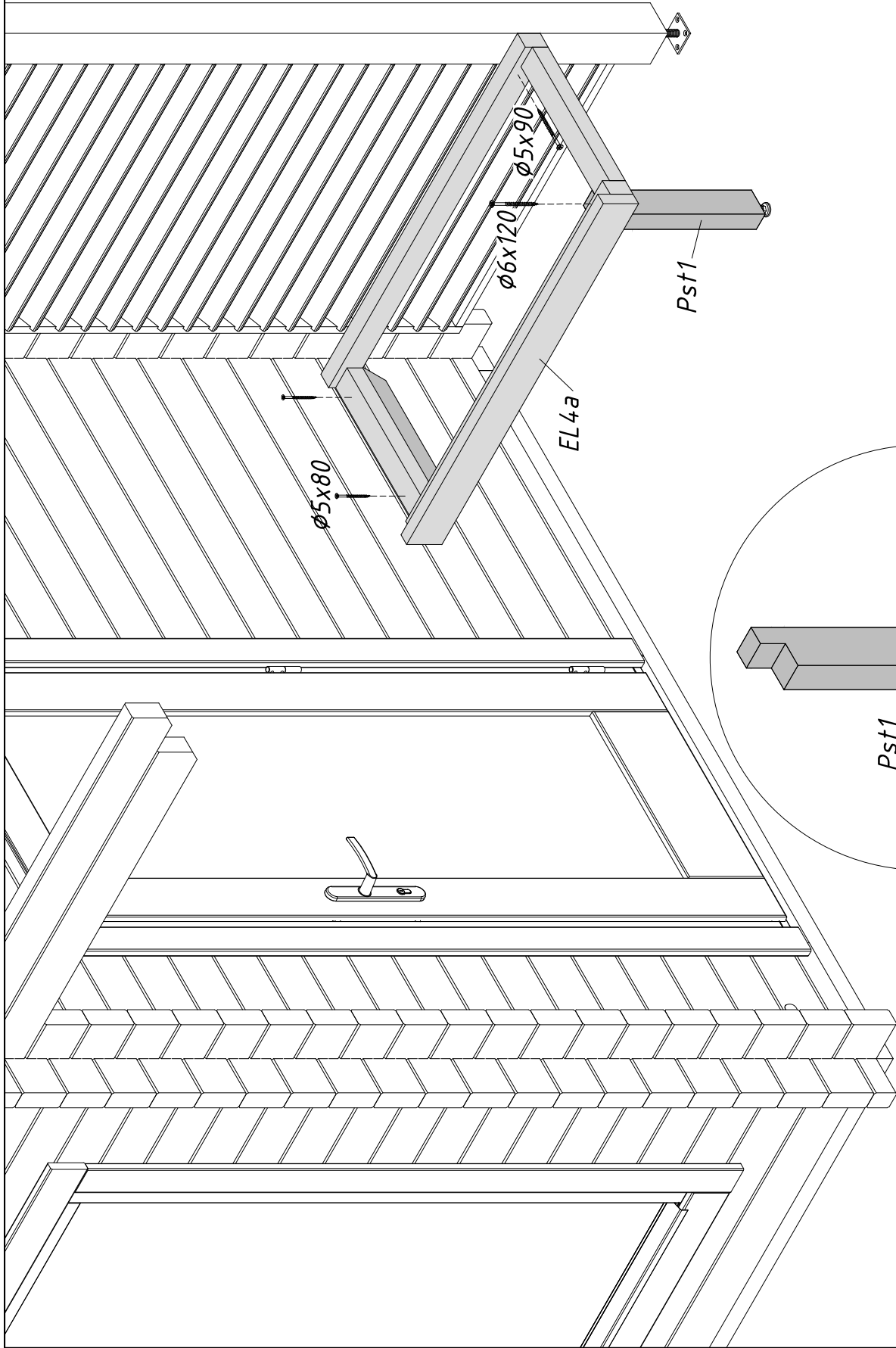

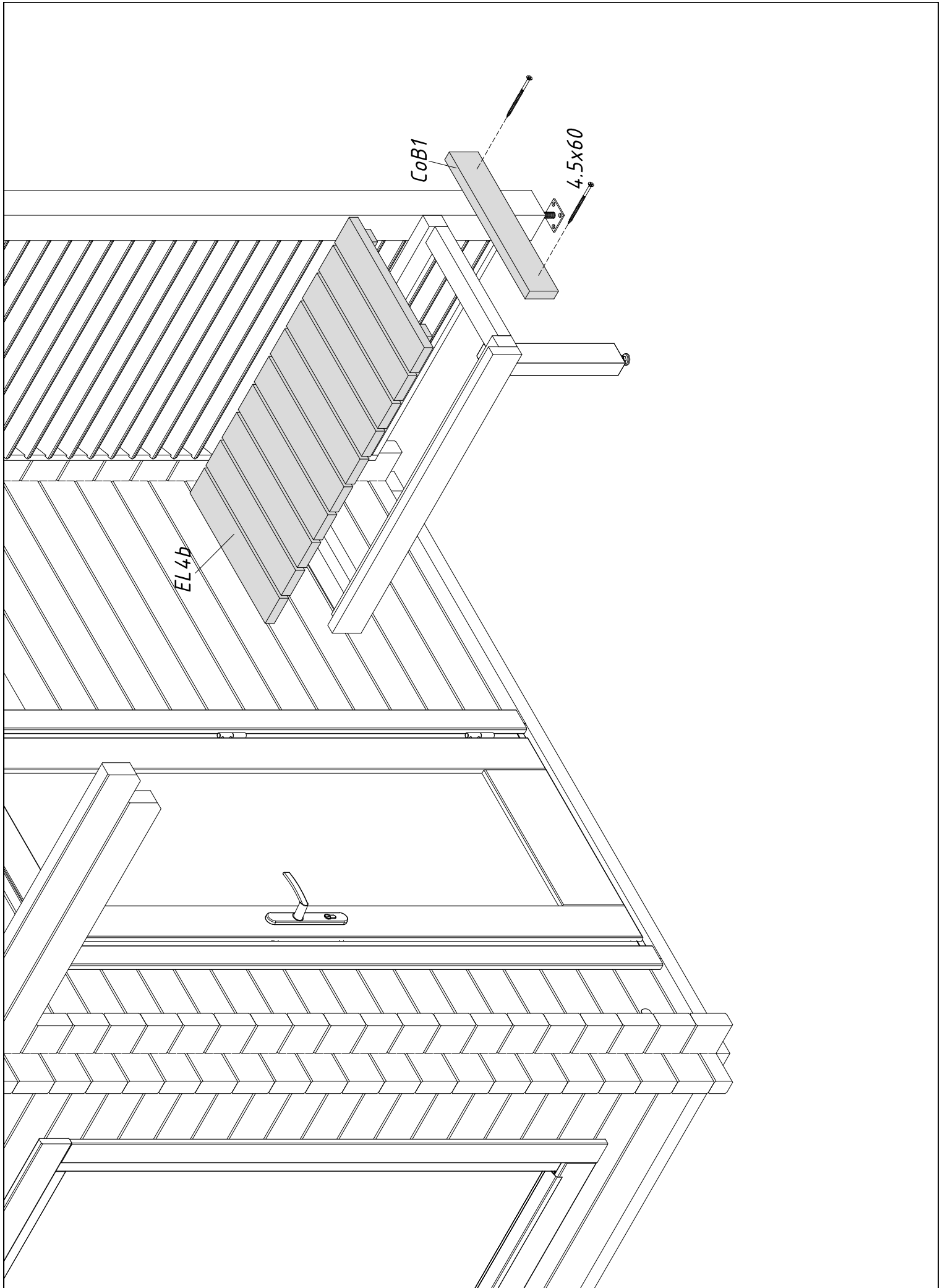

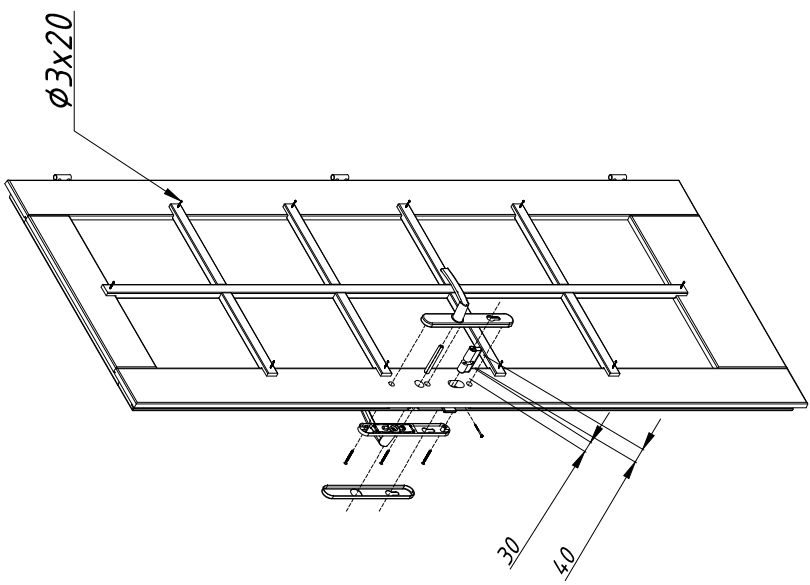
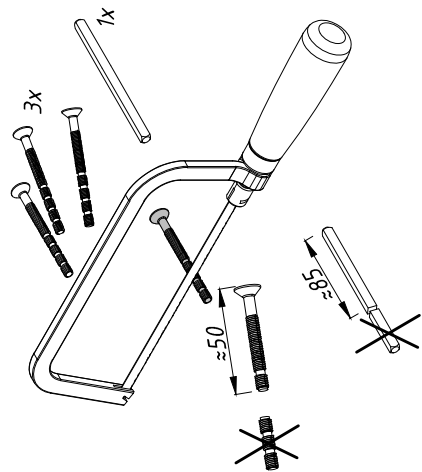
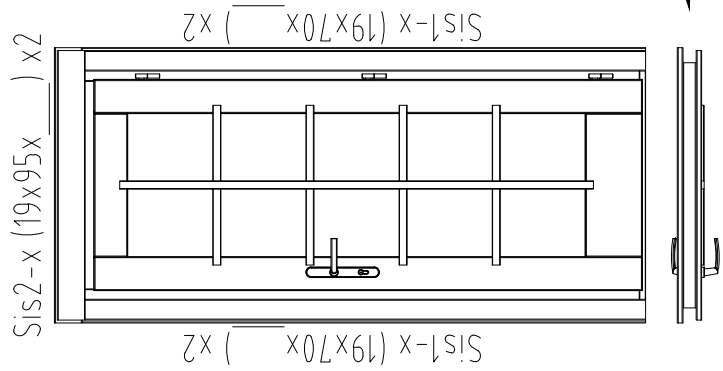
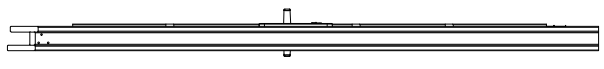
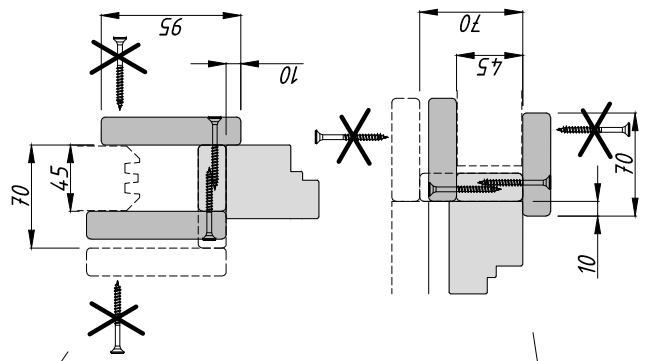
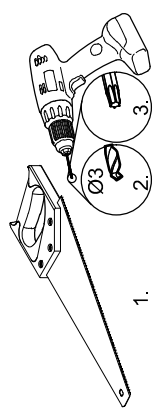
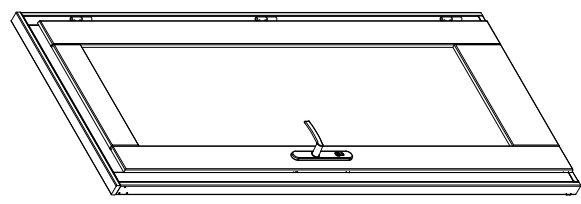
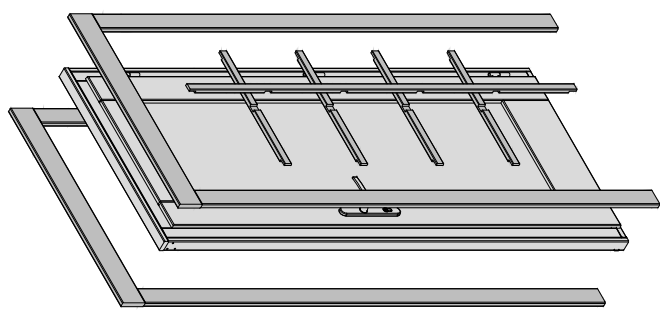
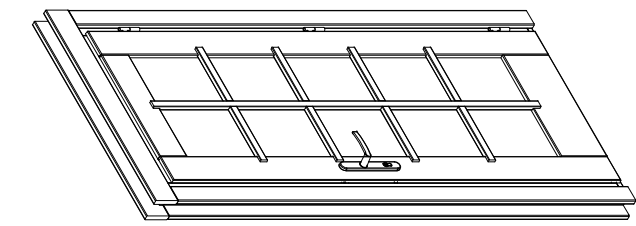

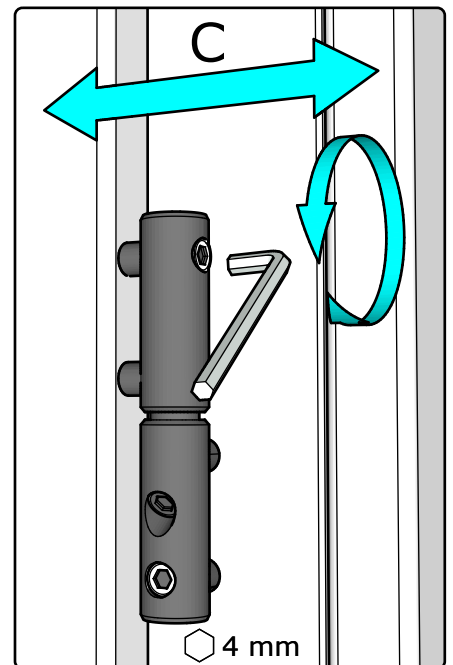
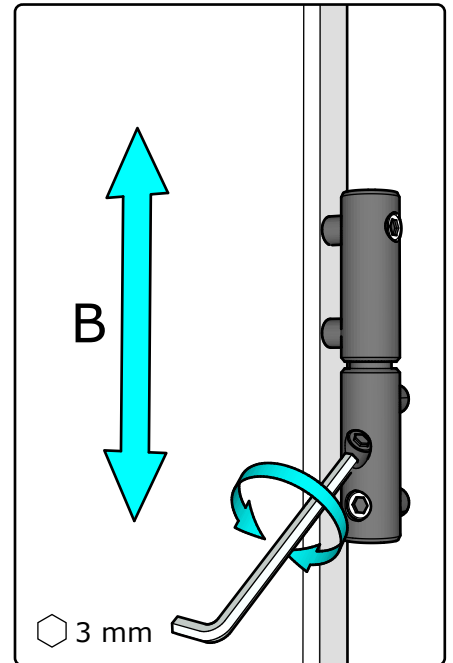
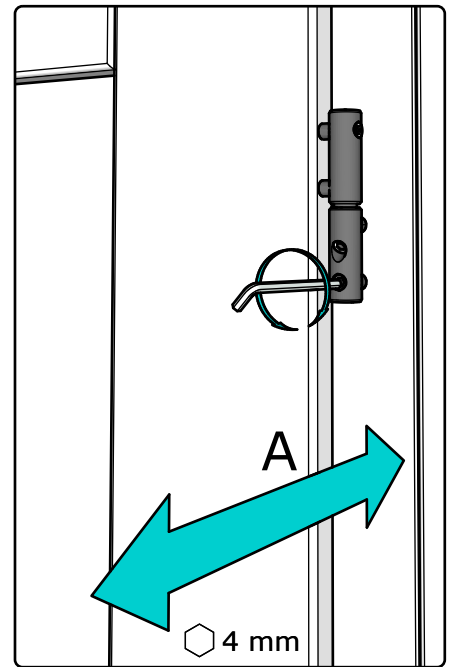
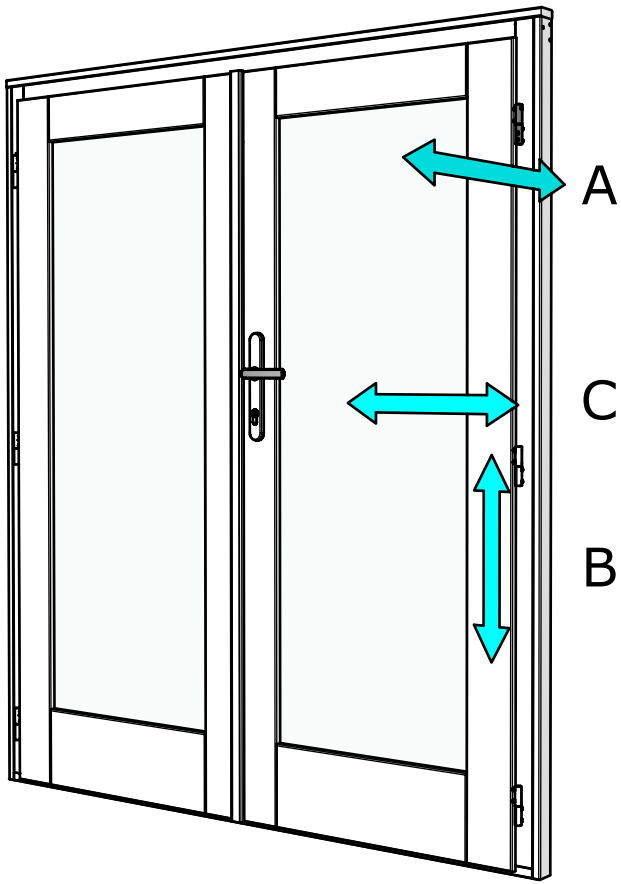

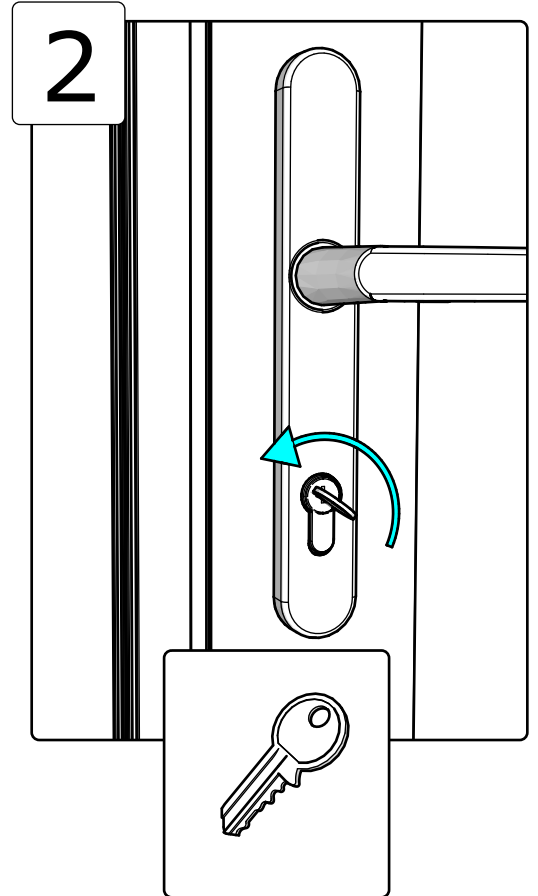
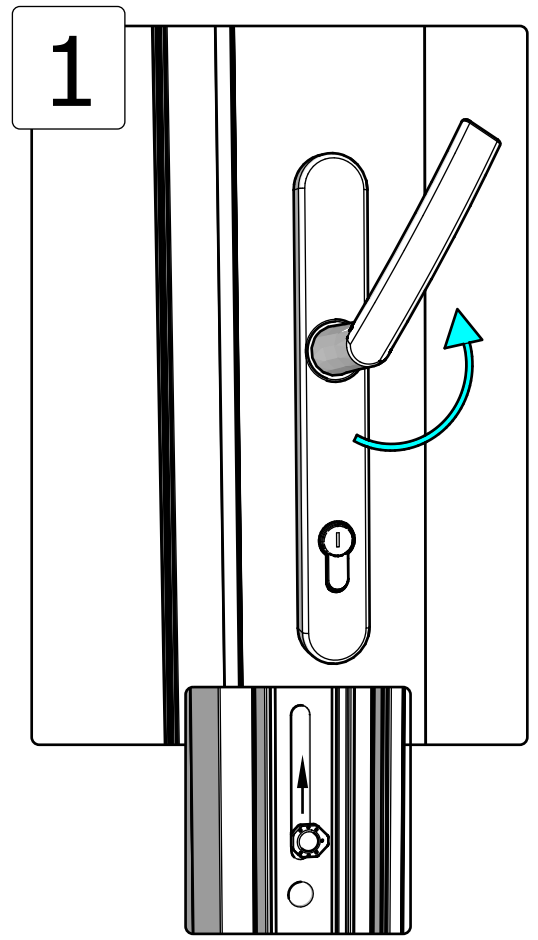
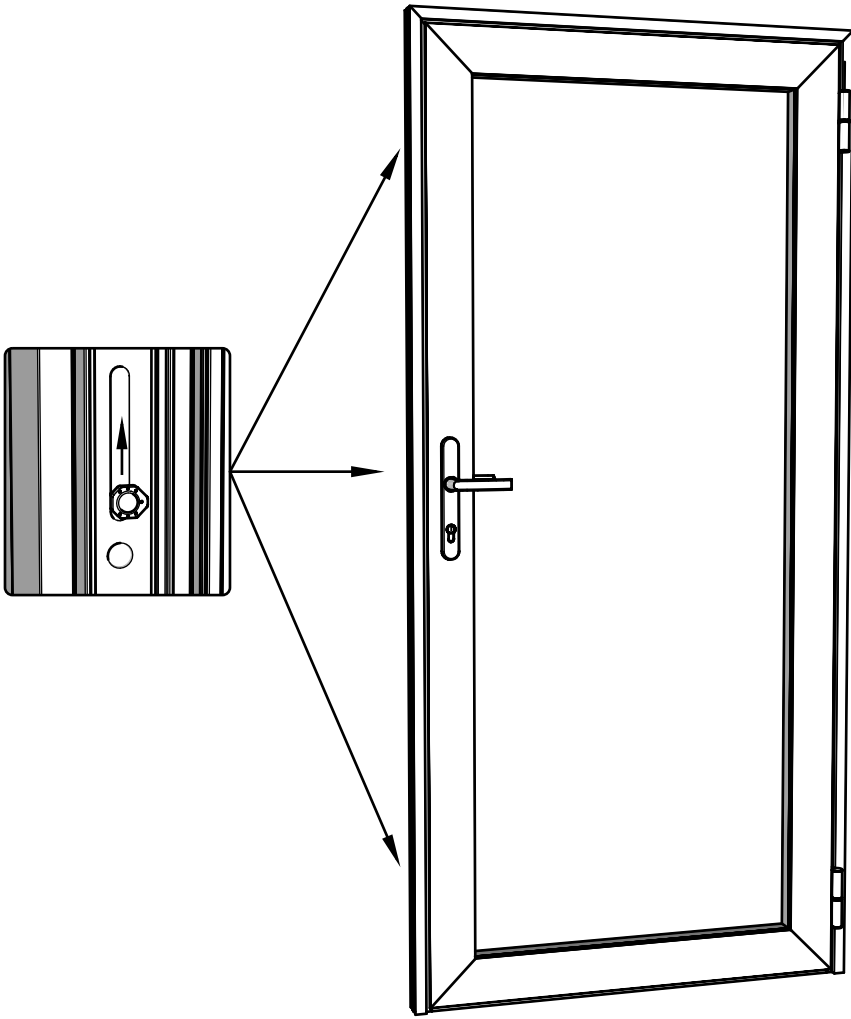

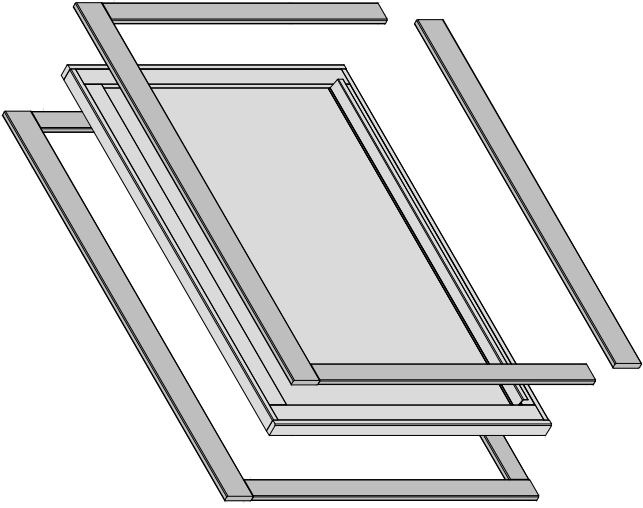
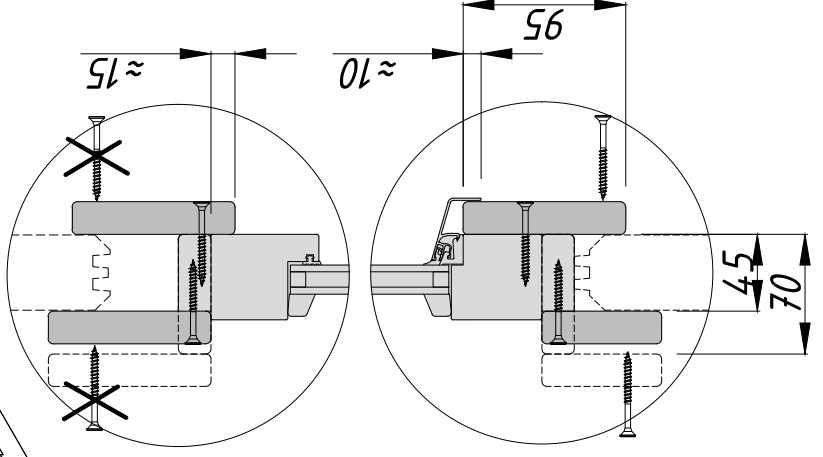
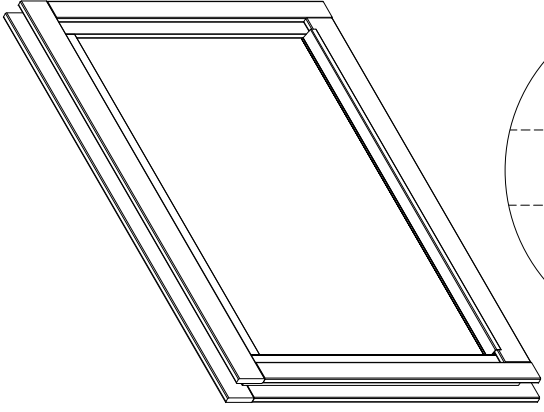

Sis2-x (19x95x) x2



Sis1-x (19x70x) x2

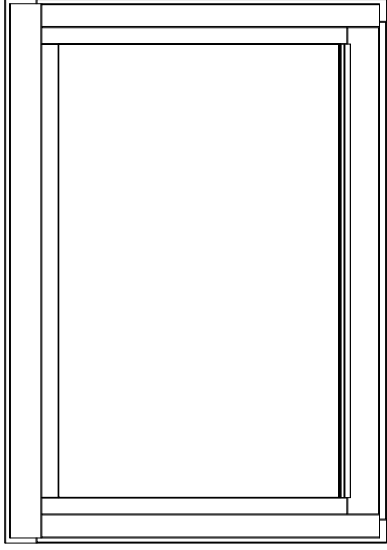

Sis2-x (19x95x) x1

Sis1-x (19x70x) x1



Sis1-x (19x70x) x2

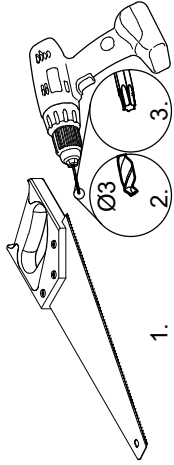
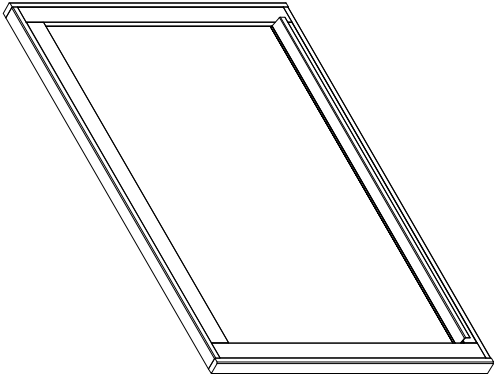

Ø4,5x50

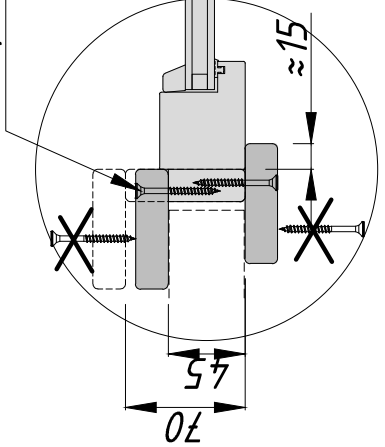

EN

When choosing a heater, the steam room size requirements of the heater manufacturer must be followed. Make sure that the minimum required safety distances from the heater are ensured for the heater to be installed.

DE

Bei der Auswahl des Saunaofens sind die Größenangaben des Herstellers zu befolgen. Vergewissern Sie sich, dass die erforderlichen Sicherheitsabstände zum Ofen eingehalten werden.

FR

Lors du choix du poêle les exigences de sécurité du fabricant doivent être respectées. Lors de l'installation veillez à ce que les distances minimales tout autour du poêle soient conformes aux prescriptions communiquées.

ES

Al seleccionar una estufa, se deben considerar los requisitos del fabricante de la estufa para el tamaño del cuarto de vapor. Asegúrese de que con la estufa que va a instalar sea posible cumplir con las distancias mínimas de seguridad requeridas desde el cuerpo calefactor.

IT

Quando si sceglie una stufa per sauna, è necessario rispettare i requisiti dimensionali della sala vapore indicati dal produttore della stufa stessa. Assicurarsi che siano rispettate le distanze di sicurezza minime richieste per l'installazione della stufa.

NO

Ved valg av badstueovn, må produsenten av badstueovnens krav i forhold til rommets størrelse følges. Sørg for at alle minimum sikkerhetsavstander fra ovnen er ivaretatt for ovnen som skal installeres.

SE

När du väljer en kamin måste basturummets storlekskrav från kaminens tillverkare följas. Se till att minsta nödvändiga säkerhetsavstånd från värmaren är säkerställda för kaminen som ska installeras.

FI

Kiuasta valittaessa on noudatettava kiukaan valmistajan suosituksia saunan koosta. Varmista, että kiuasta asennettaessa noudatetaan kiukaan vähimmäisturvaetäisyyksiä.

DK

Når du vælger en ovn, skal du sørge for, at de specifikationer, som producenten har angivet for saunarummet, er opfyldt. Sørg for, at minimumssikkerhedsafstandene fra ovnen er til stede, så ovnen kan installeres.

NL

Bij de keuze van de verwarmers moeten de eisen die de fabrikant van de verwarmers aan de grootte van de stoomkamer stelt, worden opgevolgd. Zorg er bij de installatie van de heater voor dat de vereiste veiligheidsafstand tot de heater in acht wordt genomen.

PT

Ao escolher um aquecedor, devem ser seguidos os requisitos do fabricante do aquecedor relativamente ao tamanho da cabine. Certifique-se de que as distâncias de segurança mínimas exigidas para a instalação do aquecedor estão garantidas.

CZ

Při výběru kamen je třeba dodržet požadavky výrobce kamen na velikost sauny. Při instalaci kamen se ujistěte, že prostor umožňuje dodržet minimální požadované bezpečnostní vzdálenosti.

PL

Przy wyborze generatora pary należy przestrzegać wymagań producenta dotyczących wymiarów łaźni parowej. Przed montażem generatora, należy upewnić się, że minimalne bezpieczne odległości od generatora pary są zachowane.

LT

Renkantis šildytuvą, reikia vadovautis šildytuvo gamintojo keliamais garinės pirties dydžio reikalavimais. Pasirūpinkite, kad montuojant šildytuvą būtų paisoma minimalių reikalingų saugių atstumų nuo šildytuvo.

LV

Izvēloties krāsni, ir jāievēro krāsns ražotāja prasības attiecībā uz pērtuves izmēru. Uzstādot krāsni, nodrošiniet, lai tiktu ievērots minimālais drošības attālums ap to.

RU

При выборе печи необходимо руководствоваться требованиями производителя печи к размерам парной. При установке печи должны быть соблюдены минимально необходимые безопасные расстояния вокруг нее.

ET

Kerise valikul tuleb lähtuda kerisetootja nõuetest leiliruumi suurusele. Veenduge, et paigaldatava kerise puhul on võimalik tagada minimaalsed nõutud ohutuskaugused küttekehast.