

# OFCU3(NF/GR/AN)

V.8

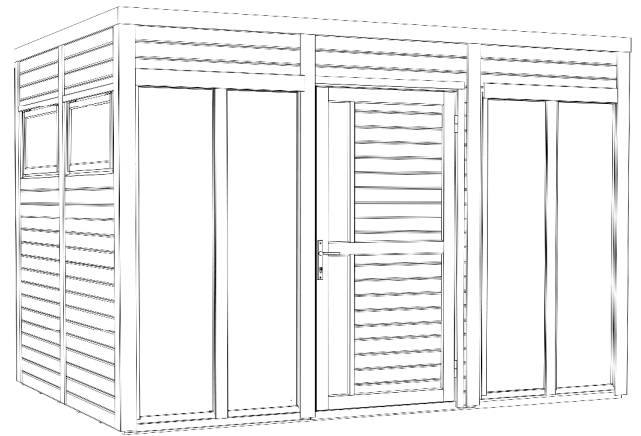
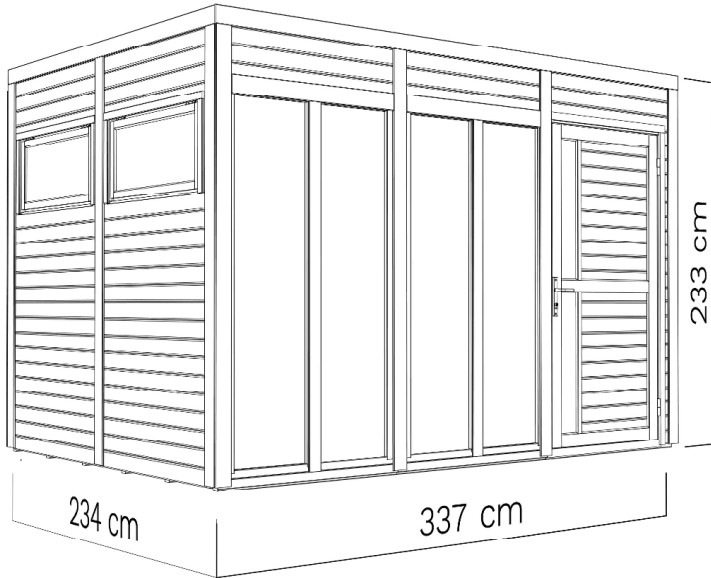

Page 19-29

**Version B**

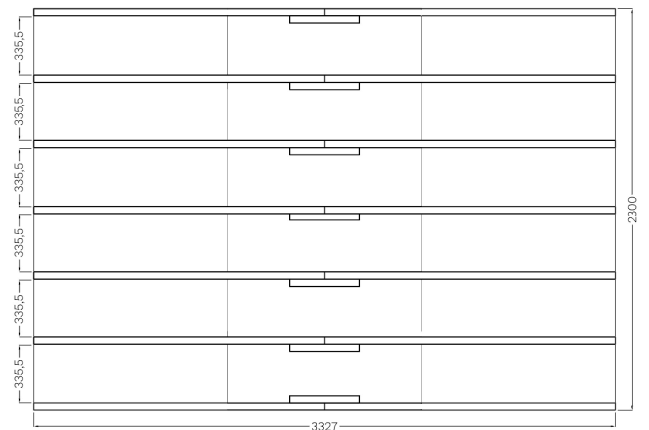
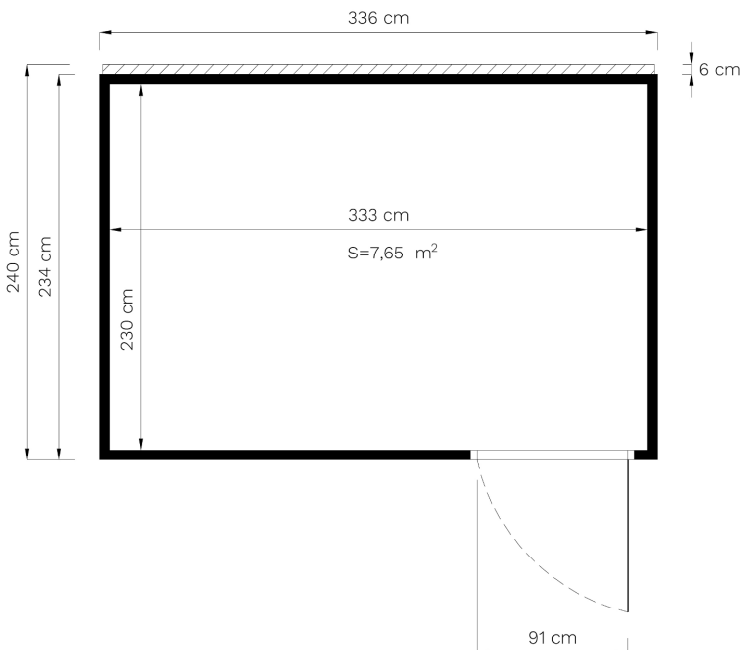

DE - Technische Änderungen vorbehalten.

Alle Maße sind ca. Maße.

EN - Technical modifications reserved.

All dimensions are approximate dimensions.



# OFCU3(NF/GR/AN)

## DE **Bevor Sie beginnen**

• Es ist empfehlenswert sich etwas Zeit zu nehmen, um die Aufbauanleitung anzusehen, bevor mit dem Aufbau begonnen wird. • Alle Schritte für den Aufbau werden – auch in Detailbildern – dargestellt. • Die vorgegebene Reihenfolge ist zu beachten. • Bitte prüfen Sie vor dem Aufbau anhand der Teileliste die Vollständigkeit und den Zustand der Lieferung. • Besonders wichtig ist der Holzschutz! Die Boden-elemente sind vor dem Aufbau von unten mit einem geeigneten Holzschutz zu behandeln! • Das für die meisten Produkte online verfügbare Datenblatt bietet weitere wichtige Hinweise für den Aufbau. • Beigefügt sind auch die Garantiebedingungen.

## FR **Avant de commencer**

• il est recommandé de prendre le temps de lire les instructions de montage avant de commencer. • Toutes les étapes du montage sont présentées, y compris sur des illustrations détaillées. • L'ordre prescrit doit être respecté. • Avant le montage, vérifiez l'exhaustivité et l'état de la livraison à l'aide de la liste des pièces. • La protection du bois est particulièrement importante! Avant le montage, les éléments de plancher doivent être traités par le bas avec un produit de protection du bois approprié! • La fiche technique disponible en ligne pour la plupart des produits fournit d'autres informations importantes pour le montage. • Les conditions de garantie y sont également jointes.

## CZ **Než začnete**

• Doporúčujeme, abyste si vzali trochu času k prohlédnutí montážního návodu, než s montáží začnete. • Všechny montážní kroky jsou zobrazeny - také na podrobných obrázcích. • Je nutné dodržovat uvedený postup. • Před montáží zkontrolujte podle seznamu dílů, zda jste obdrželi všechny díly a zda je dodávka v dobrém stavu. • Obzvláště důležitá je dřevěná botka! Podlahové prvky musí být před montáží zespoda ošetřeny vhodným ochranným přípravkem na dřevo! • Datový list, který je k dispozici online pro většinu produktů, poskytuje další důležité pokyny k montáži. • V příloze naleznete také záruční podmínky.

## DK **Før du starter**

• Det kan anbefales at tage sig tid til at kigge på samlevejledningen, før du starter samlingen. • Alle trin i samlingen bliver vist – også i detaljerede billeder. • Overhold den angivne rækkefølge. • Kontrollér, at leveringen er fuldstændig og i den rette tilstand ved hjælp af delelisten, før du starter samlingen. • Særligt vigtig er træbeskyttelsen! Gulvelementerne skal behandles med egnede træbeskyttelse nedefra, før du starter samlingen! • Til de fleste produkter kan du finde datablade online, der indeholder yderligere vigtige informationer til samlingen. • Garantibetingelserne er også vedlagt.

## NL **Voordat u begint**

• Het is aan te bevelen om de tijd te nemen om de opbouwhandleiding door te nemen voordat er met het opbouwen wordt begonnen. • Alle stappen voor het opbouwen worden - ook met gedetailleerde afbeeldingen - weergegeven. • Neem de aangegeven volgorde in acht. • Controleer voor het opbouwen aan de hand van de onderdelenlijst de volledigheid en de hoedanigheid van de levering. • Bijzonder belangrijk is de bescherming van het hout! De vloerelementen moeten voor het opbouwen van onderen met een geschikt houtbeschermingsmiddel worden behandeld! • Het voor de meeste producten online beschikbare gegevensblad bevat verdere belangrijke aanwijzingen voor de opbouw. • Bijgevoegd zijn ook de garantiebepalingen.

## PL **Przed rozpoczęciem**

• Wskazane jest, aby przed przystąpieniem do montażu zapoznać się z instrukcją montażu. • Pokazane są wszystkie etapy montażu – również na szczegółowych zdjęciach. • Należy przestrzegać podanej kolejności. • Przed montażem należy skorzystać z listy części, aby sprawdzić, czy dostawa jest kompletna i w dobrym stanie. • Ochrona drewna jest szczególnie ważna! Przed montażem elementy podłogowe należy zabezpieczyć od dołu odpowiednim środkiem do konserwacji drewna! • Arkusz danych, który jest dostępny online dla większości produktów, zawiera dalsze ważne informacje dotyczące montażu. • Załączone są również warunki gwarancji.

## SV **Innan du börjar**

• Vi rekommenderar att du åsidosätter lite tid för att titta igenom monteringsanvisningen innan du påbörjar monteringen. • Alla monteringsstegen visas – även med detaljerade bilder. • Den angivna ordningen måste följas. • Kontrollera att leveransen är komplett och i gott skick innan monteringen påbörjas med hjälp av listan över delar. • Träskyddet är av yttersta vikt! Golvelementen ska behandlas underifrån med lämpligt träskyddsmedel före monteringen! • Annan viktig information före montering finns i databladet (tillgängligt online för de flesta produkter). • Garantivillkoren bifogas också.

## RO **Înainte să începeți**

• Vă recomandăm să dedicați puțin timp pentru a consulta Instrucțiunile de asamblare înainte de a începe asamblarea. • Toate etapele de asamblare sunt prezentate amănunțit - și în forma unor figuri detaliate. • Respectați ordinea specificată. • Înainte de asamblare, vă rugăm să verificați lista de componente pentru a vă asigura că furnitura este completă și în stare bună. • Acordați o deosebită atenție protecției lemnului! Elementele de podea trebuie tratate de dedesubt cu o substanță conservantă adecvată pentru protecția lemnului înainte de asamblare! • Fișa de date, care este disponibilă și online pentru majoritatea produselor, oferă informații suplimentare importante cu privire la asamblare. • Atașat veți găsi și condițiile de garanție.











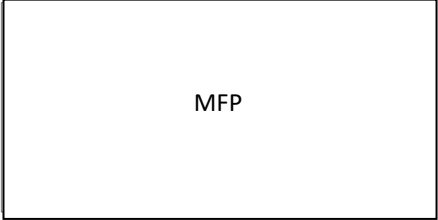
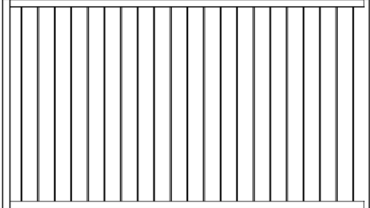
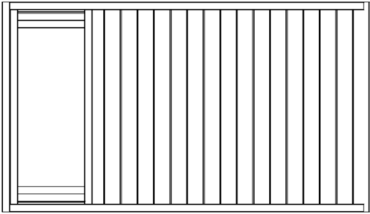
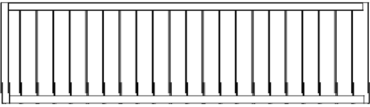
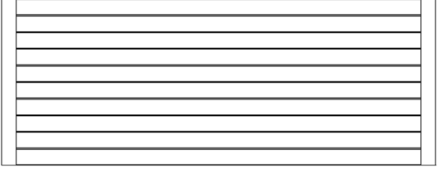
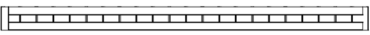

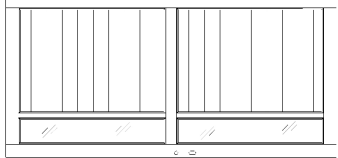









## EE **Soovitused enne paigalduse alustamist**

• Soovitame enne paigalduse alustamist võtta aega ja tutvuda paigaldusjuhendiga. • Kõik kokkupaneku etapid on näidatud ka üksikasjalikel piltidel. • Paigaldustööd tuleks teha etteantud järjekorras. • Enne paigalduse alustamist kontrollige detailide nimekirja alusel, kas kõik elemendid on olemas ja ega need pole kahjustada saanud. • Puidukaitse on eriti oluline! Põrandaelemente tuleb enne kokkupanekut töödelda altpoolt sobiva puidukaitsevahendiga! • Andmeleht, mis on enamiku toodete kohta internetis saadaval, pakub kokkupanekuks täiendavat olulist teavet. • Lisatud on ka garantiitingimused.











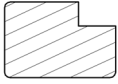
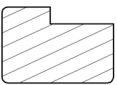

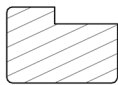

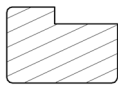
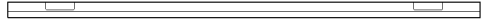



## EN **Before assembly**

• We recommend that time is taken to read the assembly instructions prior to assembly. • All assembly steps are shown – also in detailed images. • The step-by-step instructions must be followed. • Before assembly, please use the parts list to check that all components are accounted for and in good condition. • Wood protection is particularly important! The floor elements must be treated from below with a suitable wood preservative before assembly! • The data sheet, which is available online for most products, offers further important information for assembly. • The guarantee conditions are also attached.





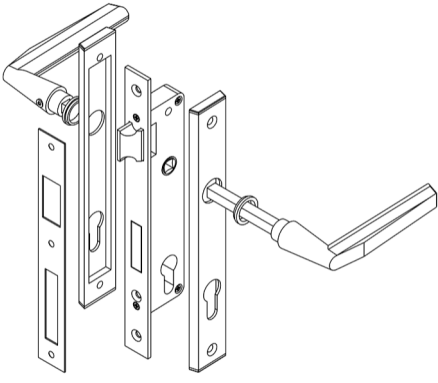
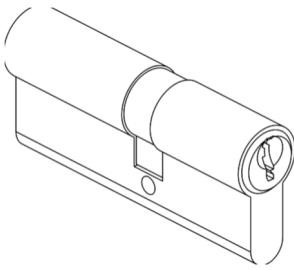
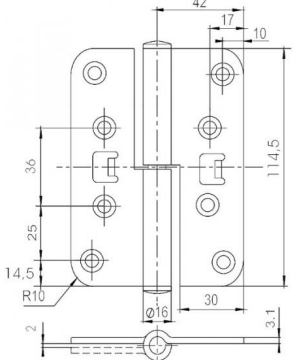
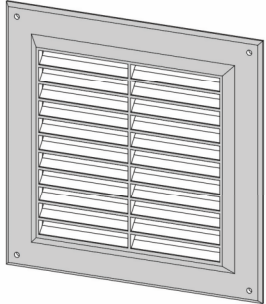



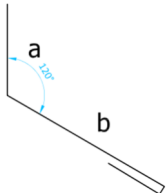

# OFCU3(NF/GR/AN)

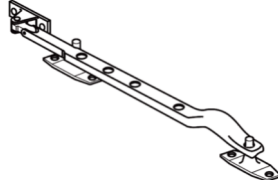
ID	Details in mm (Tolerance/Toleranz ...+ 2mm)	Pcs.	ID	Details in mm (Tolerance/Toleranz ...+ 2mm)	Pcs.
<b>1112</b>	16 x 1109 x 2300 	x 3	<b>148</b>	60 x 1109 x 1953 	x 4
<b>388</b>	60 x 1109 x 1953 	x 2	<b>149</b>	60 x 554 x 1953 	x 2
<b>156</b>	38 x 792 x 2218 	x 3	<b>150</b>	60 x 120 x 1953 	x 1
<b>152</b>	60 x 350 x 2218 	x 1	<b>35</b>	32 x 920 x 1868 	x 1
<b>154</b>	60 x 314 x 2218 	x 1	<b>153</b>	60 x 224 x 2218 	x 1
<b>38</b>	32 x 413 x 896 	x 2	<b>155</b>	60 x 314 x 2218 	x 1
<b>906</b>	40 x 80 x 2295 	x 8	<b>555</b>	350 x 830 	x 2
<b>642</b>	12 x 90 x 1170 	x 4	<b>559</b>	150 x 835 	x 2
<b>857</b>	40 (41) x 60 (41) x 500 	x 6	<b>668</b>	12 x 90 x 2200 	x 15
<b>732</b>	19 x 45 x 989 	x 1	<b>1242</b>	12 x 90 x 1004 	x 2
<b>595</b>	12 x 42 x 1926 	x 1	<b>756</b>	19 x 45 x 2245 	x 4
<b>1244</b>	12 x 42 x 2218 	x 1	<b>1239</b>	12 x 70 x 1840 	x 2
<b>791</b>	19 x 88 x 2218 	x 2	<b>1241</b>	12 x 42 x 995 	x 1
			<b>1235</b>	12 x 42 x 1034 	x 2

# OFCU3(NF/GR/AN)

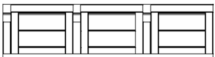
ID	Details in mm (Tolerance/Toleranz ...+ 2mm)	Pcs.	ID	Details in mm (Tolerance/Toleranz ...+ 2mm)	Pcs.	
<b>1227</b>	40 x 60 x 1877 	x 4	<b>860</b>	40 x 60 x 989 	x 1	
<b>944</b>	40 x 60 x 1878  	x 1	<b>1243</b>	40 x 60 x 2218 	x 1	
<b>707</b>	15 x 15 x 909 	x 1	<b>867</b>	40 x 60 x 1878  	x 1	
<b>1002</b>	15 x 15 x 324 	x 4	<b>1001</b>	15 x 15 x 837 	x 4	
<b>1129</b>	15 x 15 x 154	} (NB! BCCU3GR/AN) 	x 4			
<b>1131</b>	15 x 15 x 335			x 4		
<b>1135</b>	15 x 15 x 838			x 4		
<b>1114</b>	41 x 41 x 1663 	x 14	<b>1502</b>	∅4,5 x 70 	x 216	
<b>1116</b>	41 x 41 x 400 	x 7	<b>1506</b>	∅3,5 x 35 	x 204	
<b>1505</b>	∅4,5 x 50 	x190	<b>1510</b>	∅3 x 19 	x 20	
<b>1512</b>	∅1,5 x 25 	x 56				
<b>1531</b>		x 1	<b>1554</b>	ES60 (30/30) 	x 1	
<b>1527</b>	Righthand hinge 	x 2	<b>1557</b>	VR1515 Ventilation rest 	x 2	
<b>945</b>	15 x 15 x 154 	x 4	<b>946</b>	15 x 15 x 807 	x 4	

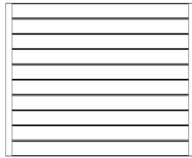
# OFCU3(NF/GR/AN)

ID	Details in mm (Tolerance/Toleranz ...-+ 2mm)	Pcs.	ID	Details in mm (Tolerance/Toleranz ...-+ 2mm)	Pcs.
1573	20 x 40 x 929 	x 2	1572		x 4
1569	Ø4,8 x 32 Dark Grey 	x 6	1525		x 2
64	60 x 513 x 1877 	x 4	1507	Ø3,5 x 30 	x 12
1501	Ø4,5 x 90 	x 4	160	60 x 350 x 1109 	x 1
161	60 x 224 x 1109 	x 1	162	32 x 792 x 1109 	x 3
658	12 x 90 x 1698 	x 2			

# NB!

Empfohlen bei Aufbau auf besonders feuchtem Untergrund.  
Recommended for assembly on moist ground.

## \* Nicht im Lieferumfang enthalten / Not included!

\* Unterlagspad /  
\* Patio Pads

Min. 18,4 lfm/rm

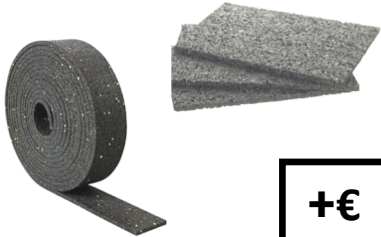

+€

\* Imprägniert Kantholz /  
\* Impregnated beam

40\*60\*2300 mm

8 Stck/Pcs

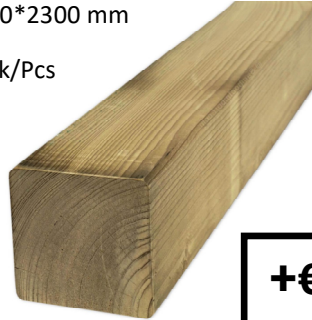

+€

\* Schraube /  
\* Screw

4,5\*80 mm

56 Stck/Pcs



+€

## Fundamentplan / Foundation Plan

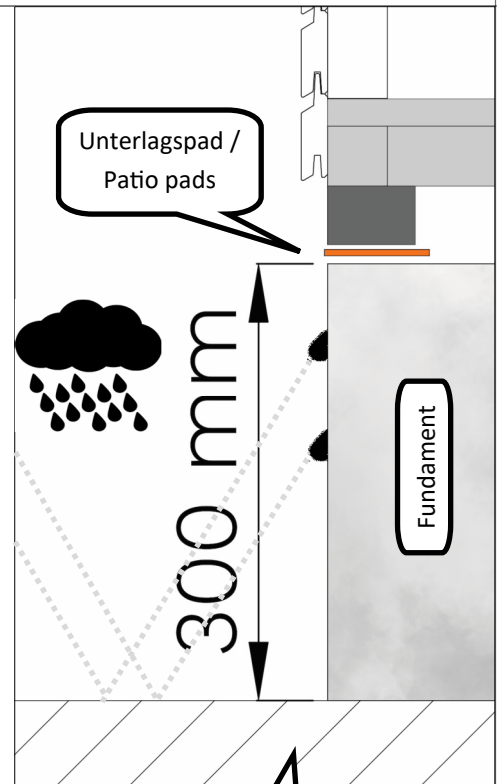
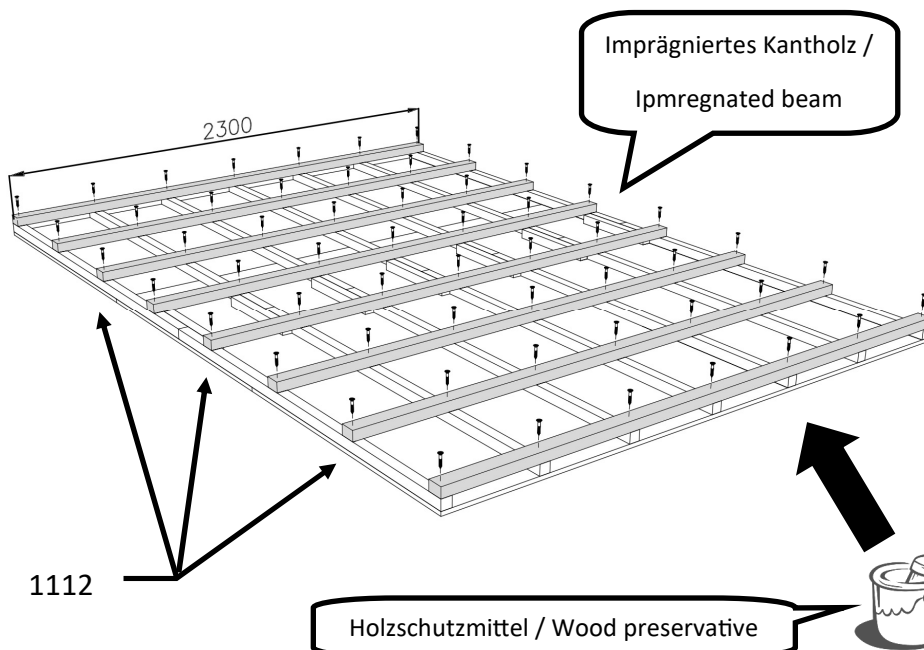
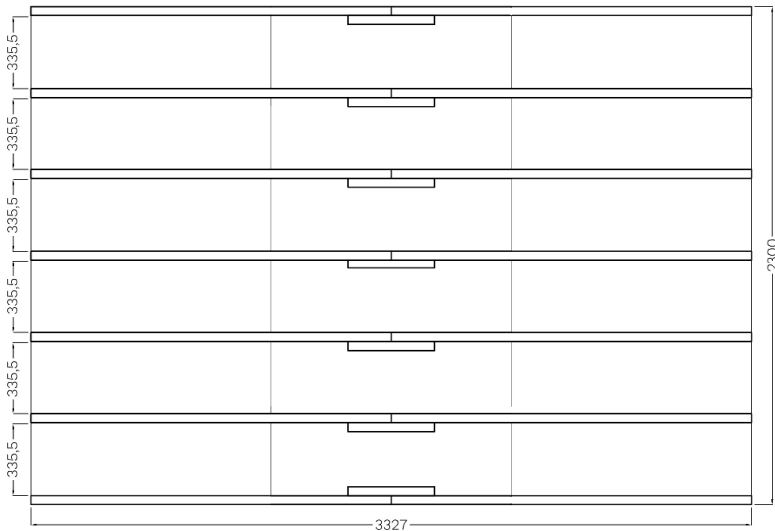

### Bitte beachten!

Lass Dein Bauvorhaben vorab bei Deiner zuständigen Gemeinde prüfen, denn die Bauordnungen sowie die Bebauungspläne müssen eingehalten werden.

### Please note!

Have your construction project checked in advance at your responsible municipality, because the building regulations and the development plans must be observed.

# OFCU3(NF/GR/AN)

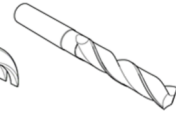
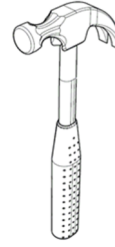
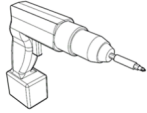

Ø 4 mm  
Ø 8 mm

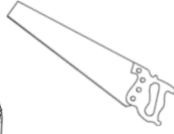
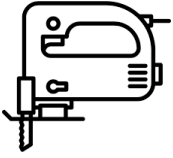

1.

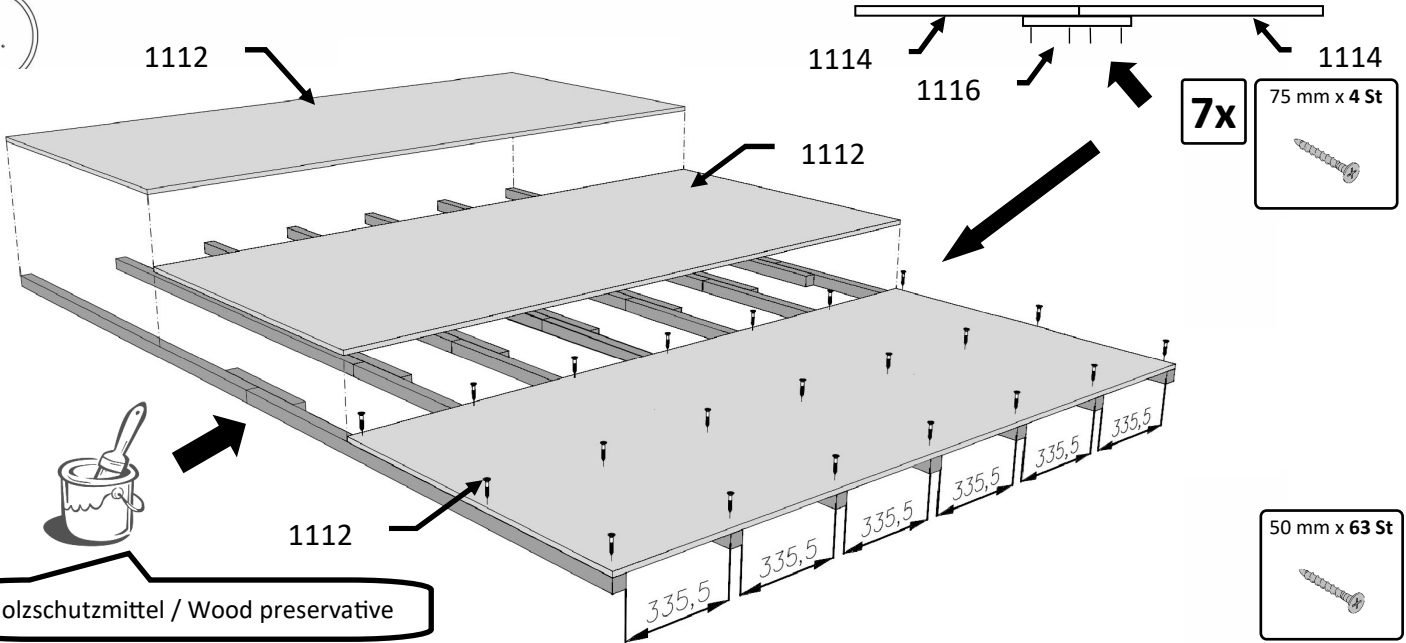

2.

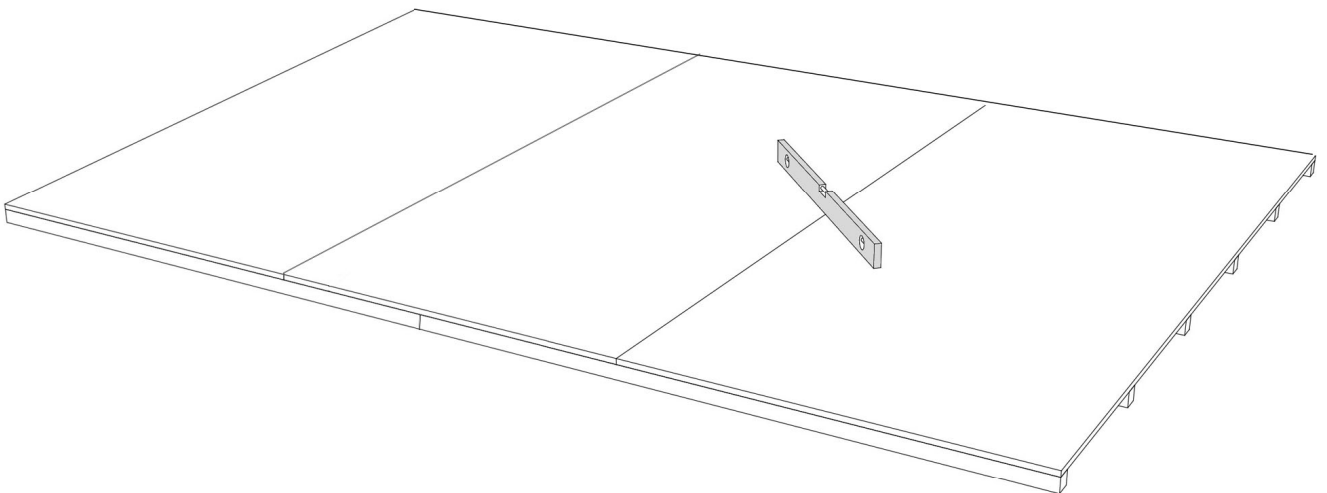

# OFCU3(NF/GR/AN)

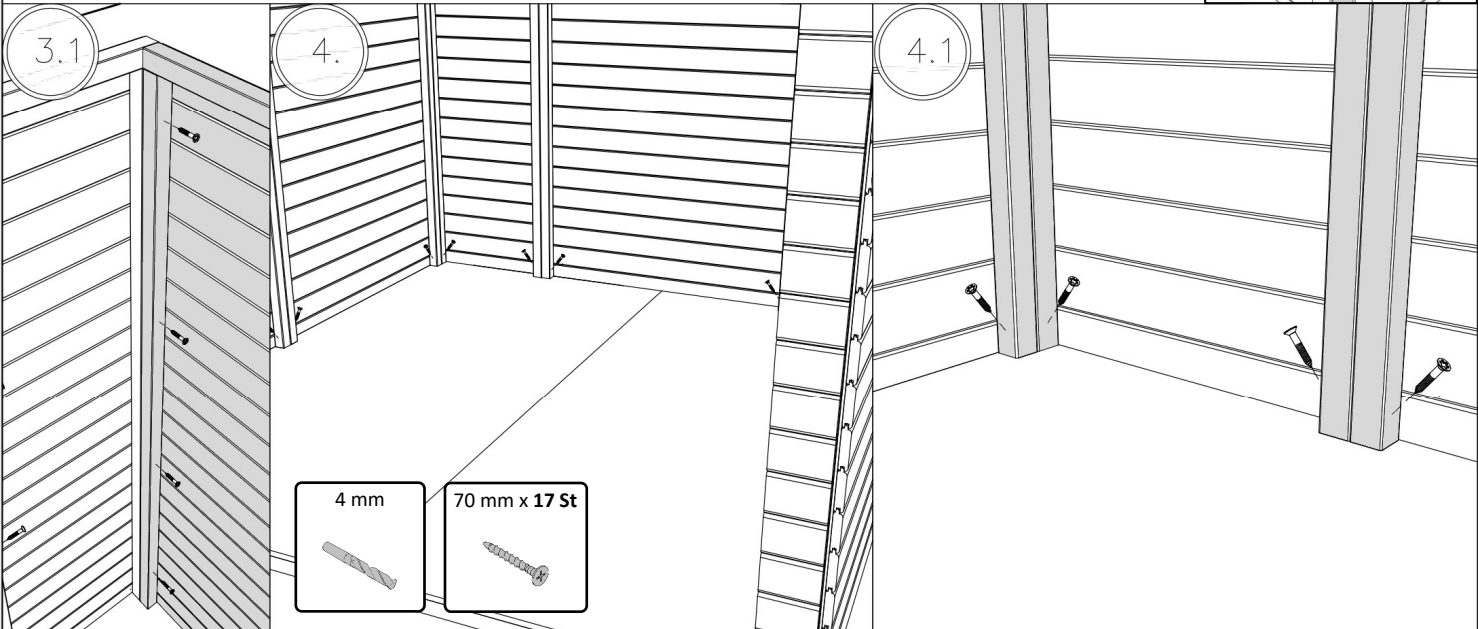
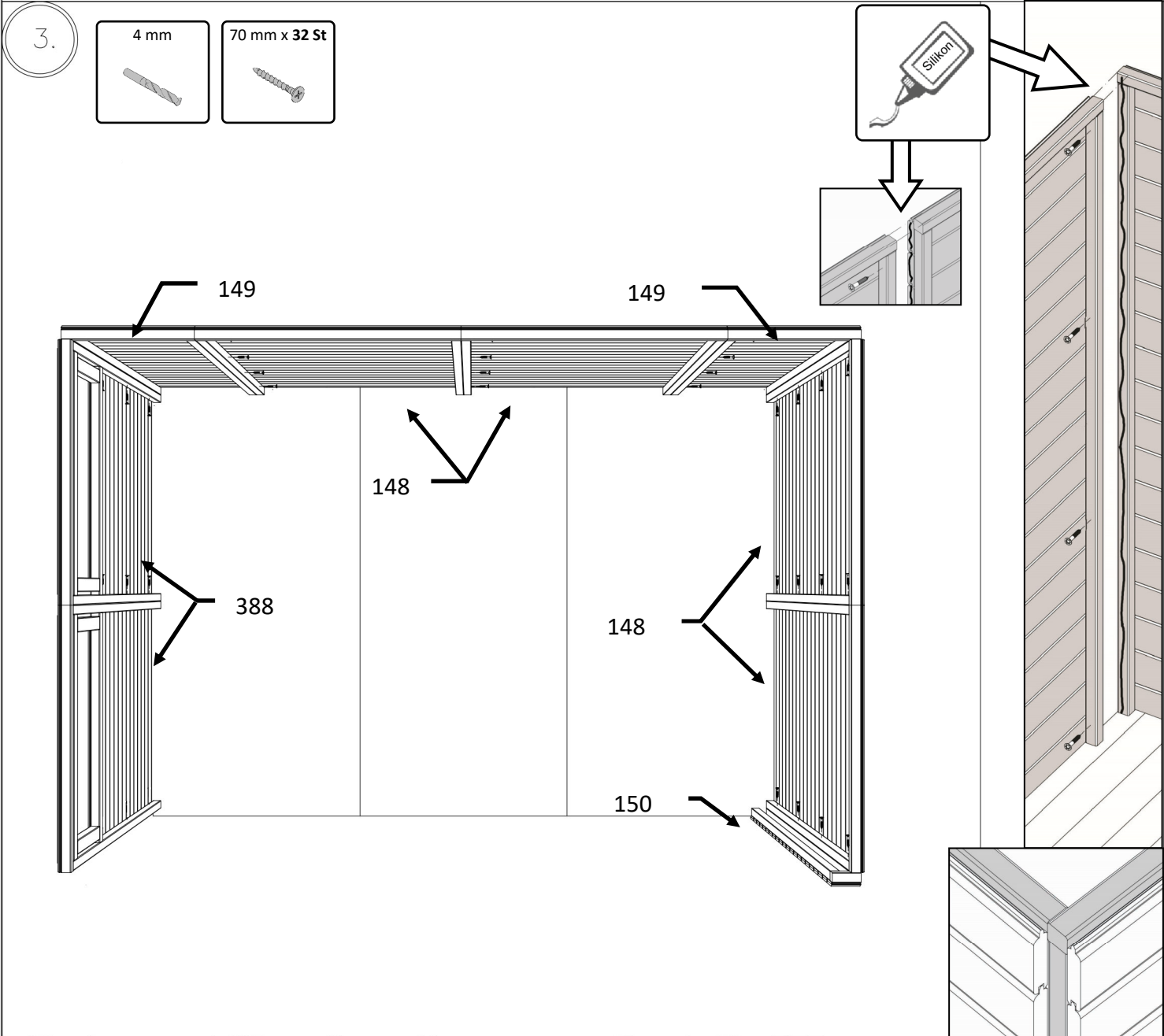

# OFCU3(NF/GR/AN)

5.

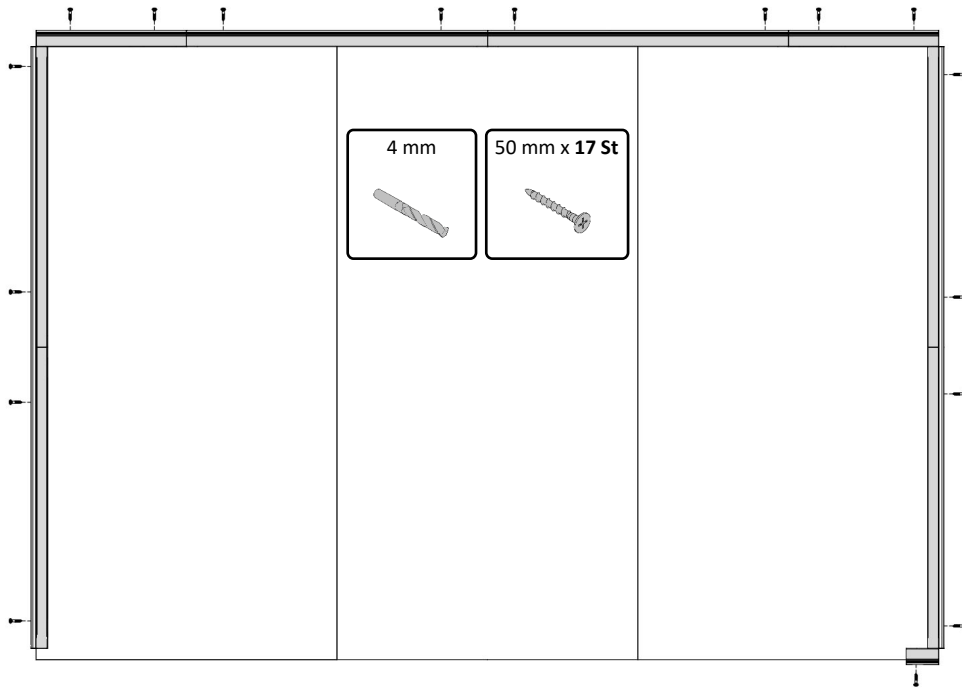

5.1

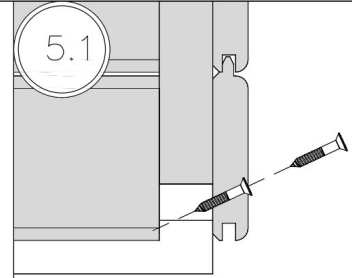

5.2



Step 7!

**Version B**

NB! Page 19-29

6.

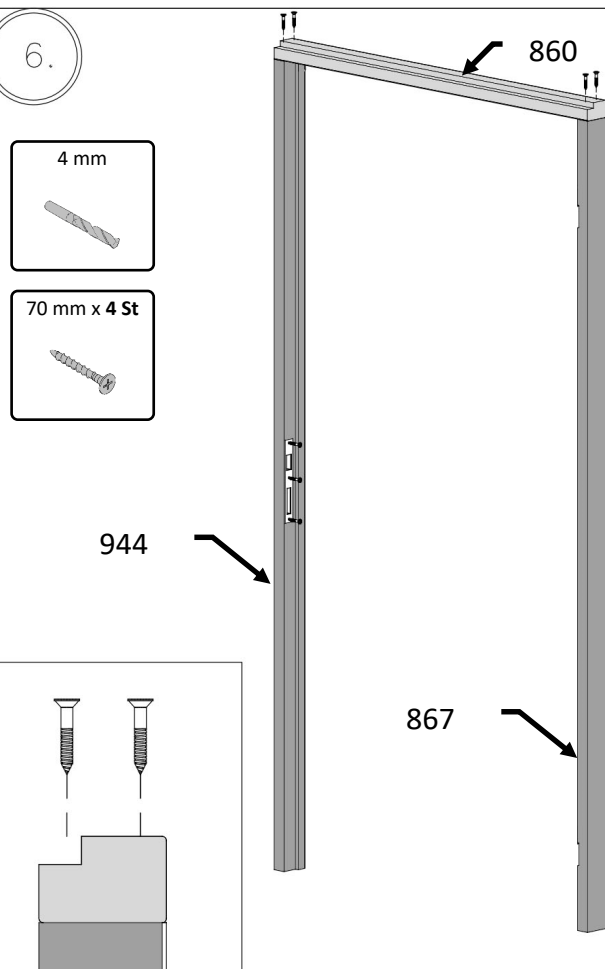

6.1

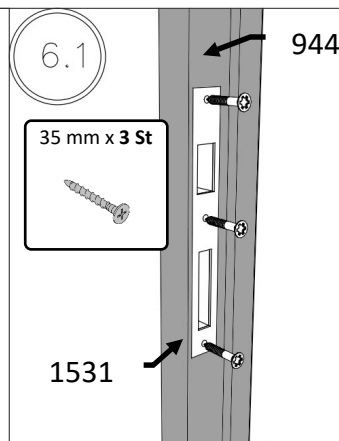

1531

7.1

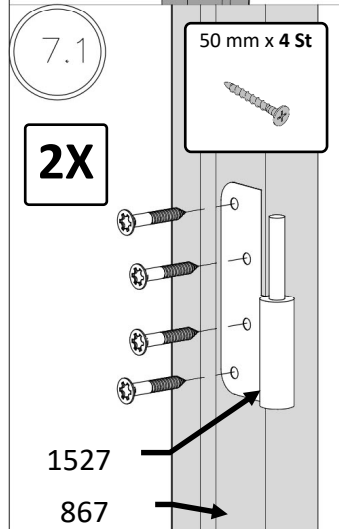

7.

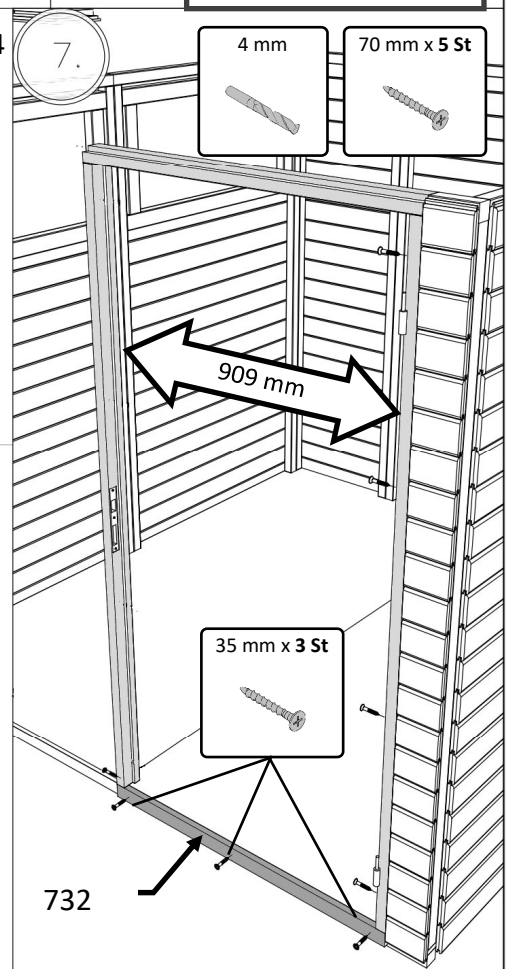

# OFCU3(NF/GR/AN)

NB! Page 19-29

**Version B**

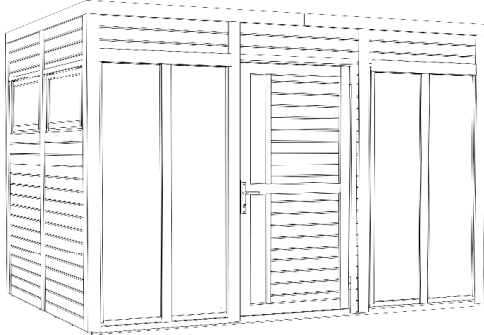

8.

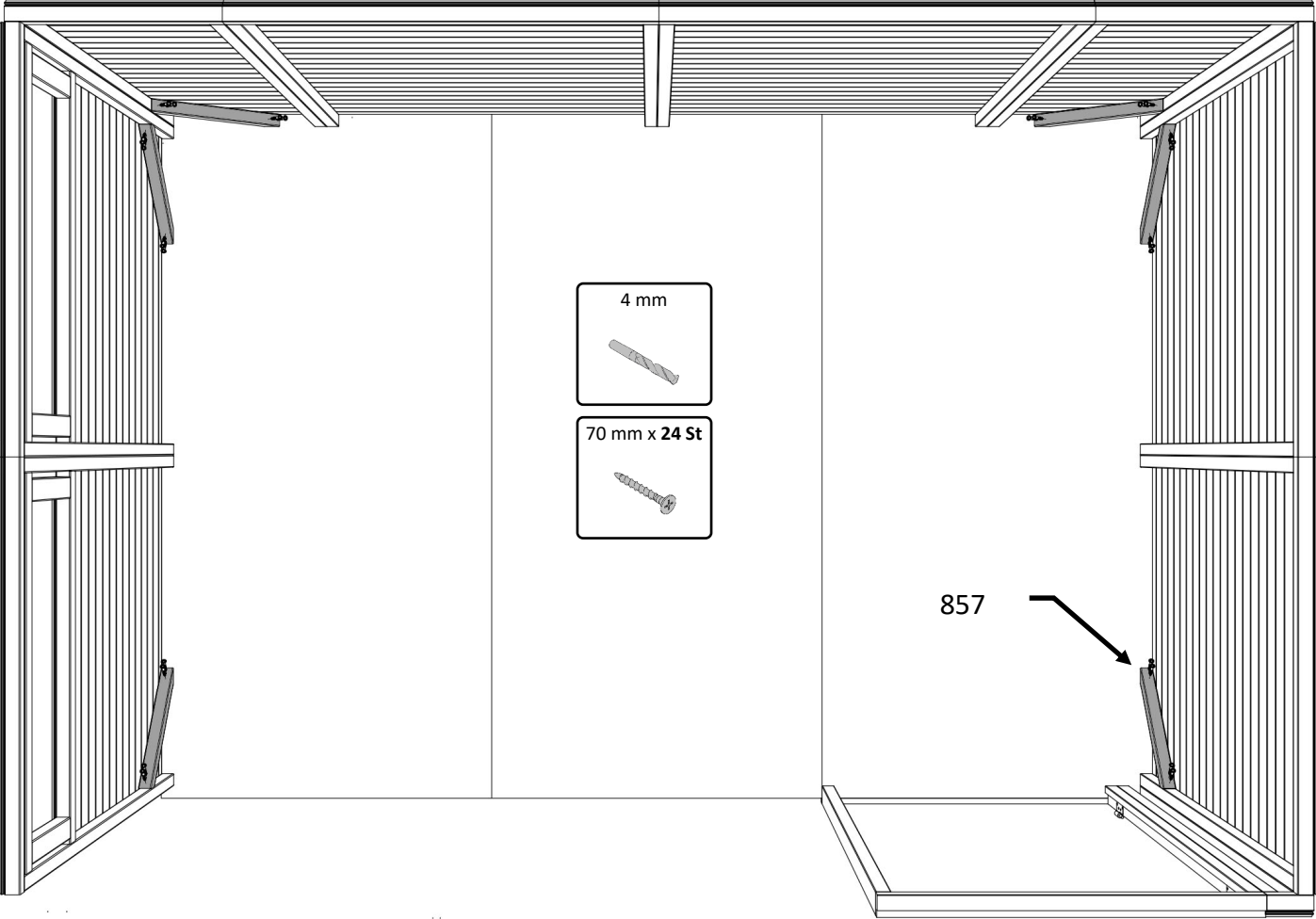

8.1

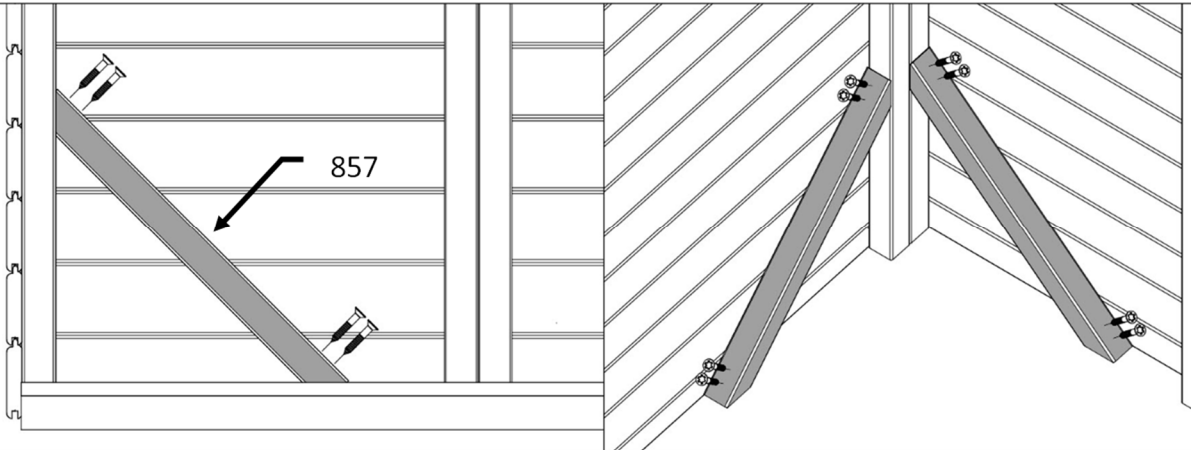

# OFCU3(NF/GR/AN)

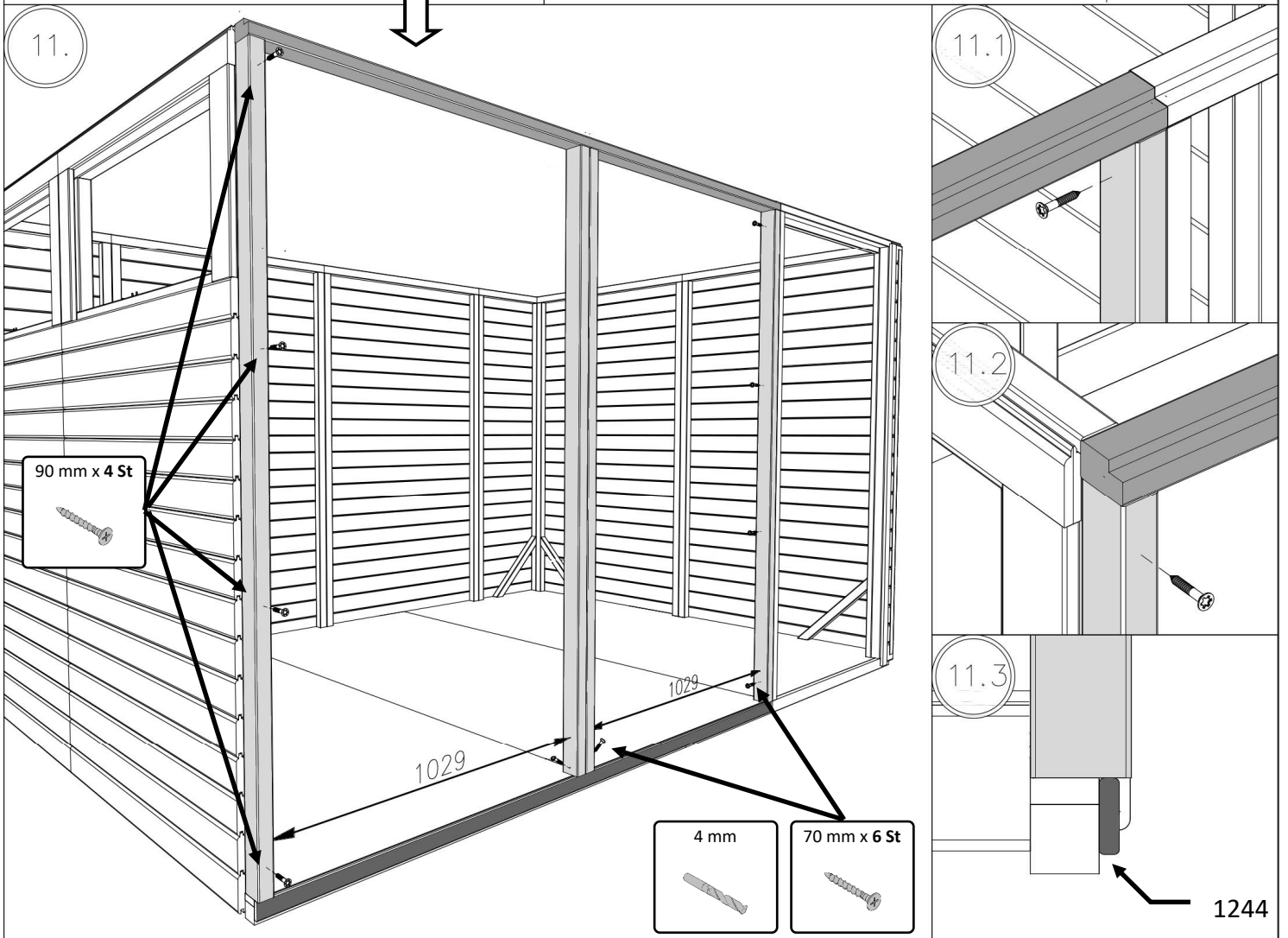
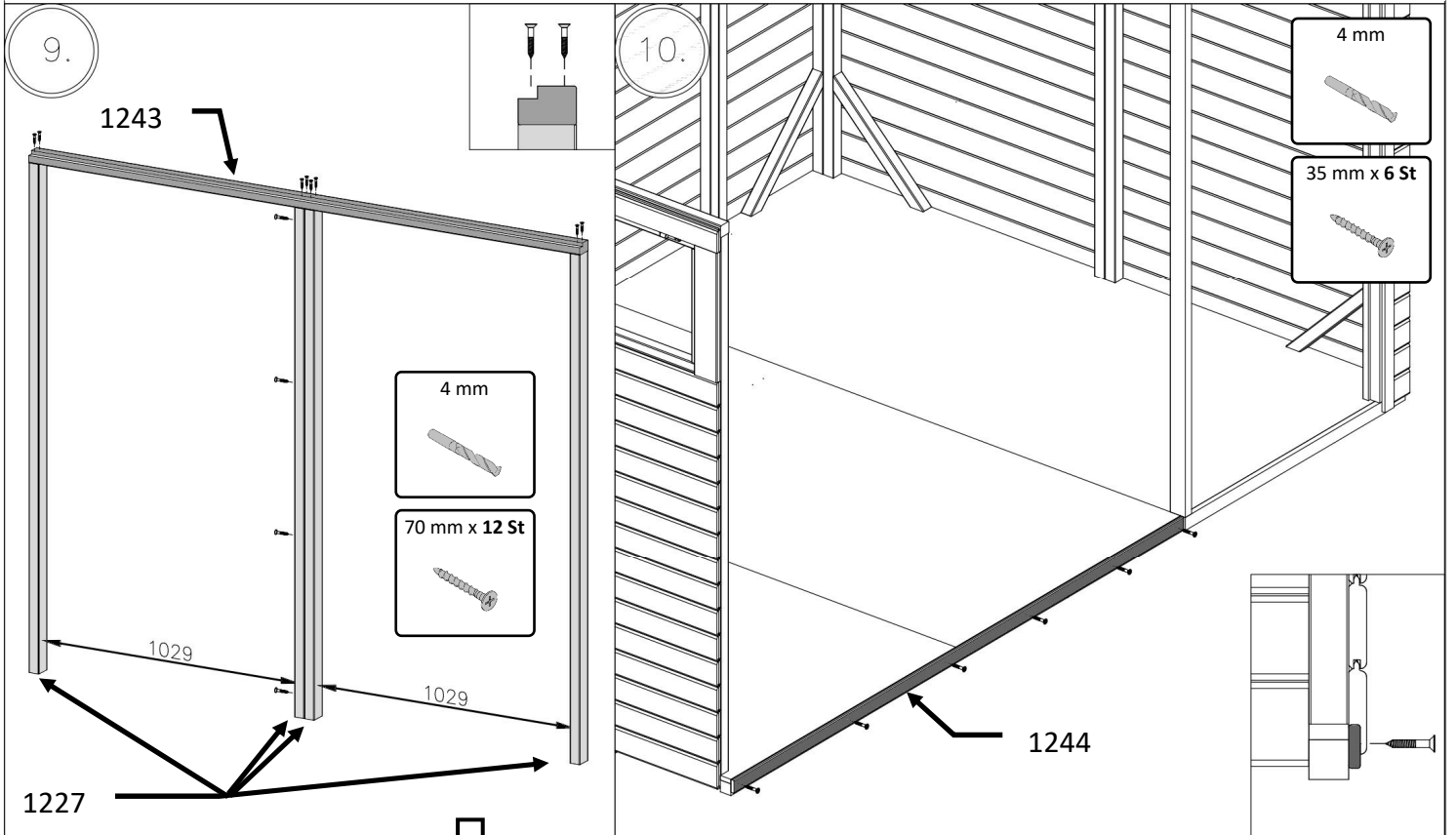

# OFCU3(NF/GR/AN)

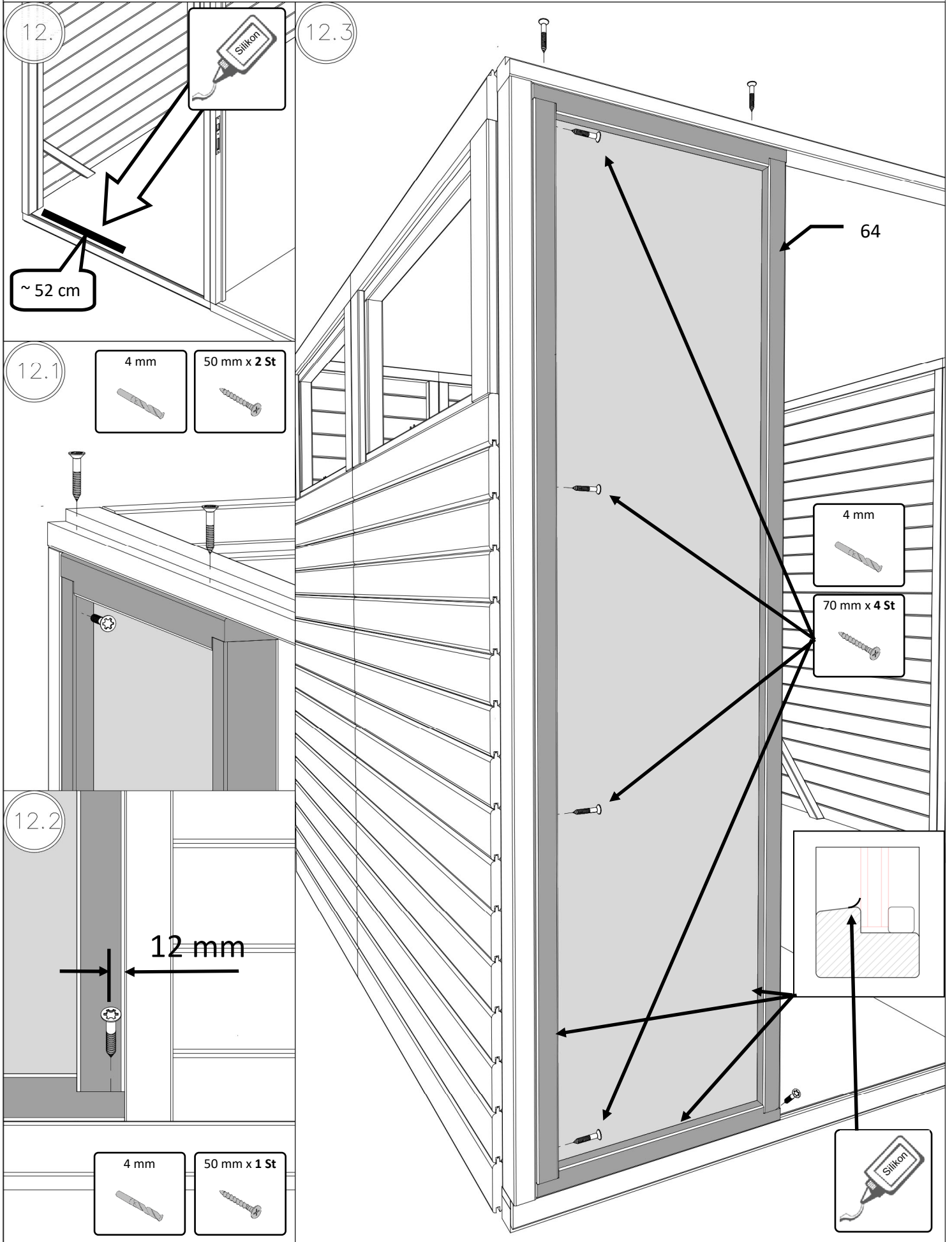

# OFCU3(NF/GR/AN)

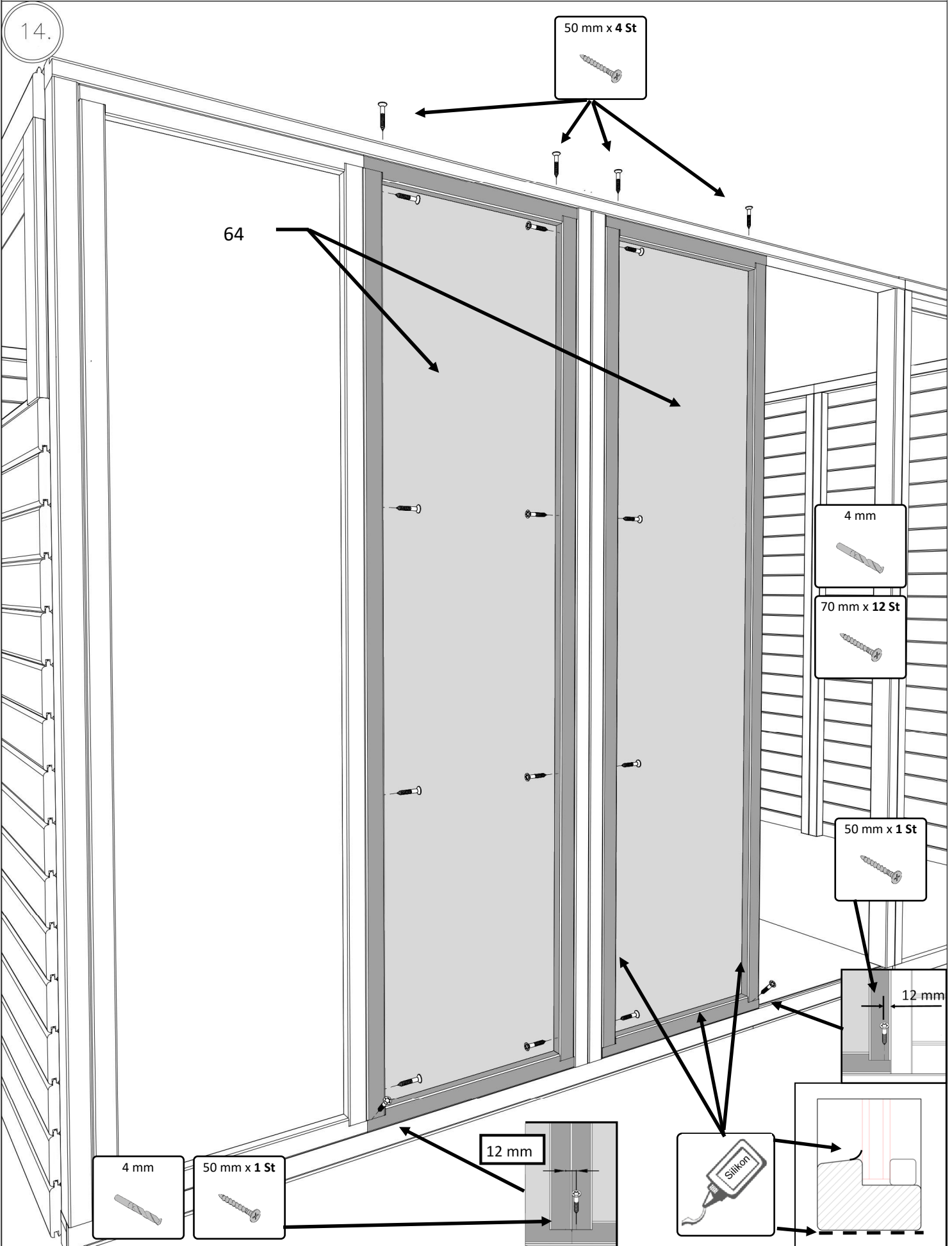

# OFCU3(NF/GR/AN)

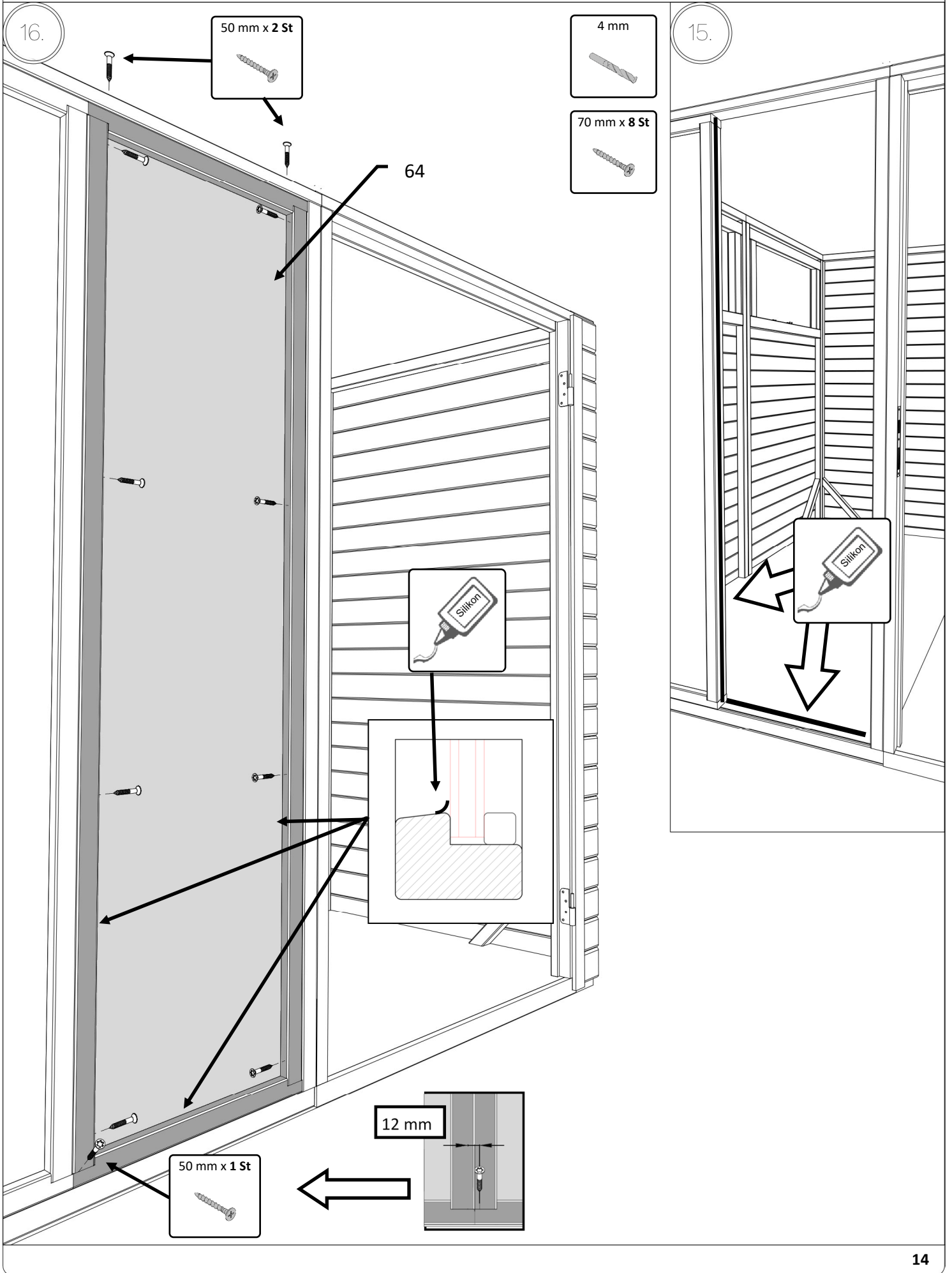

# OFCU3(NF/GR/AN)

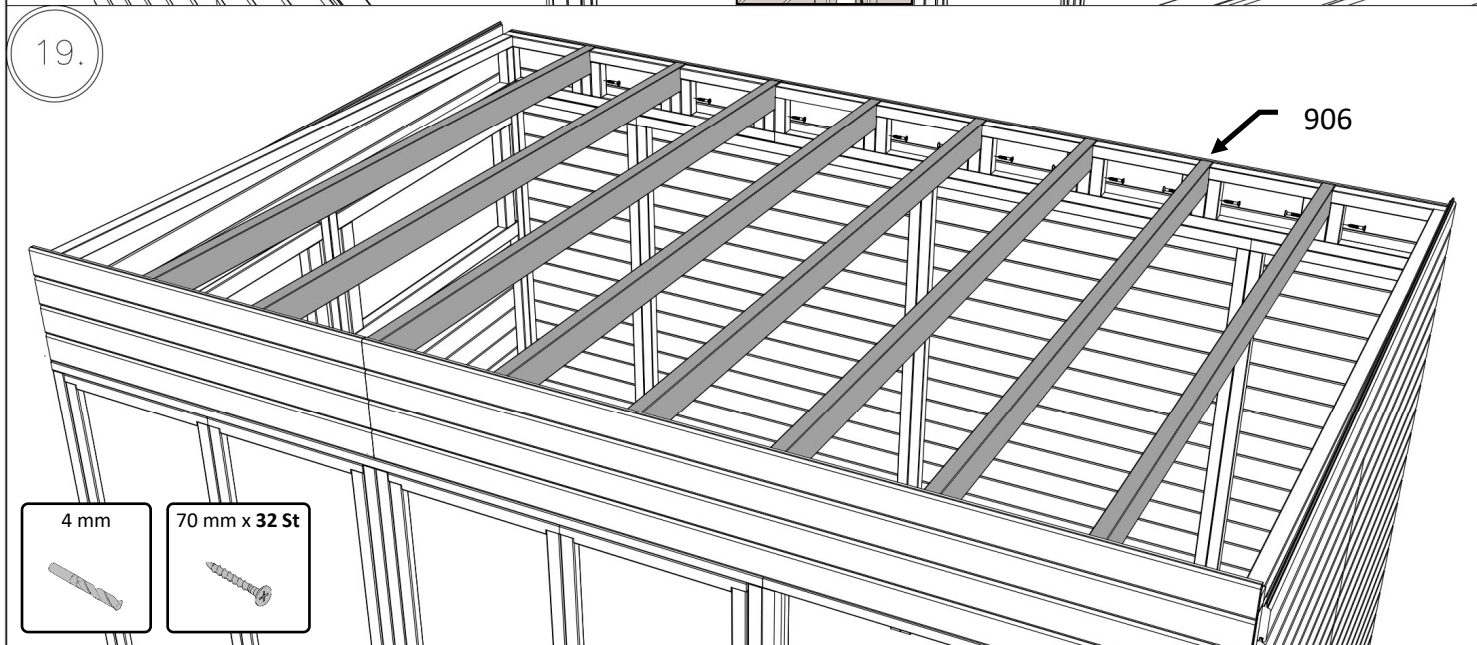
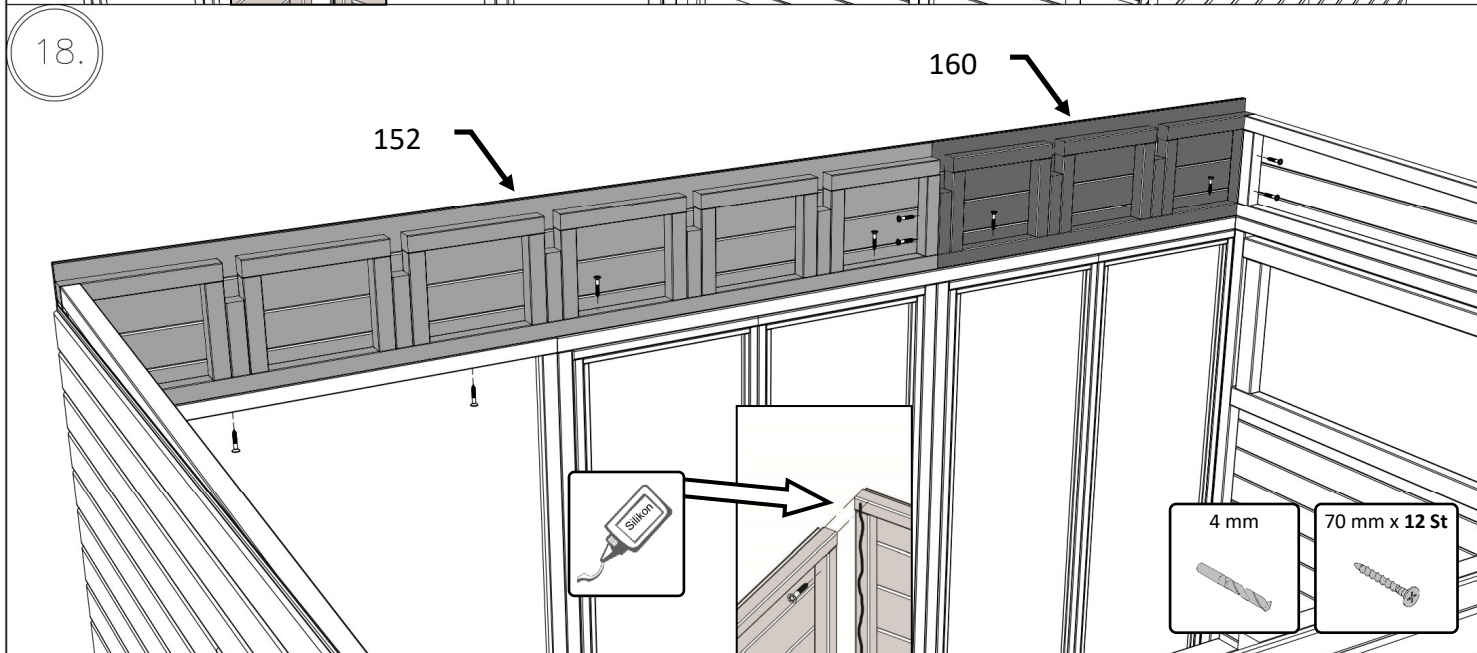
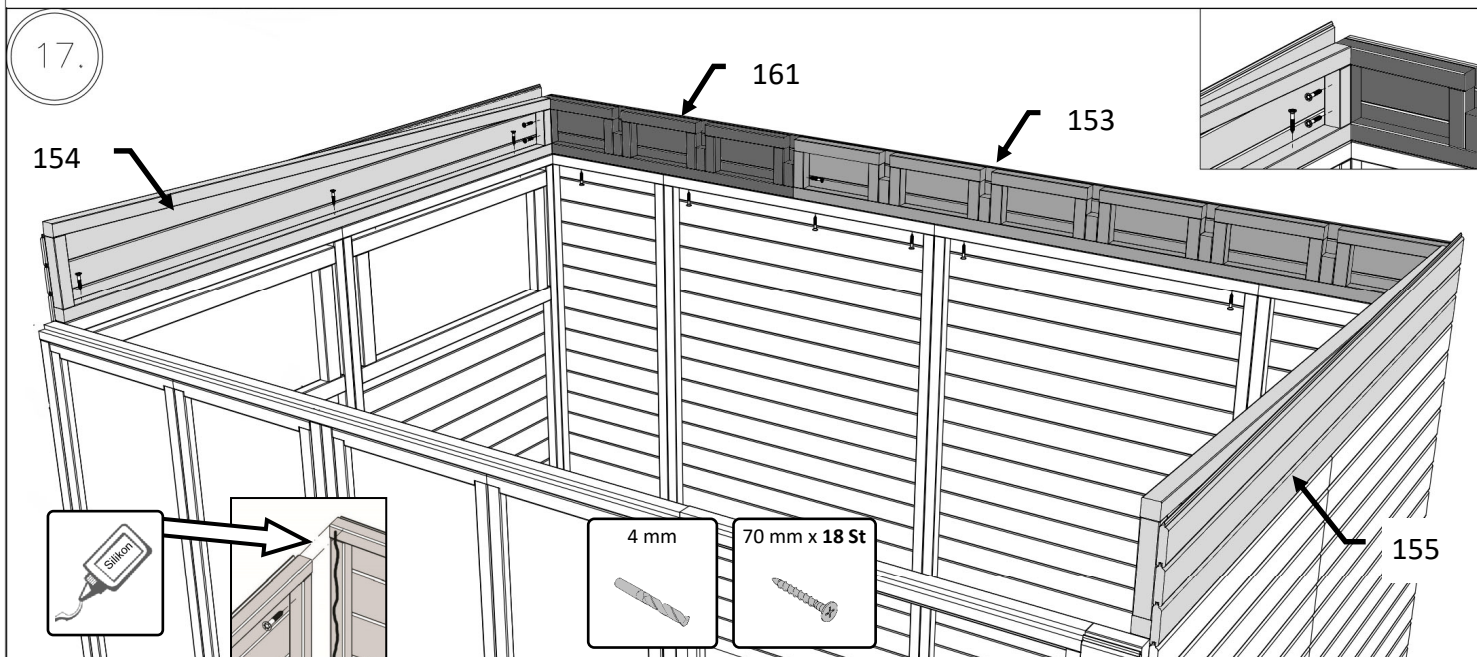

# OFCU3(NF/GR/AN)

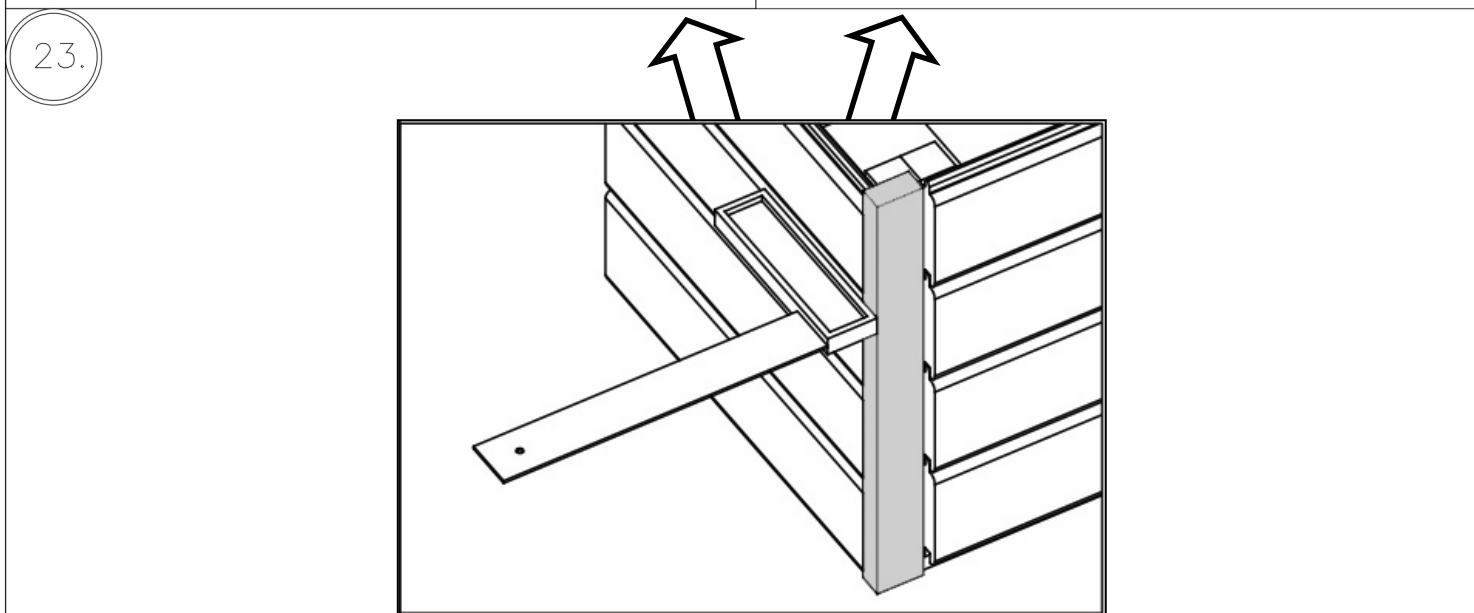
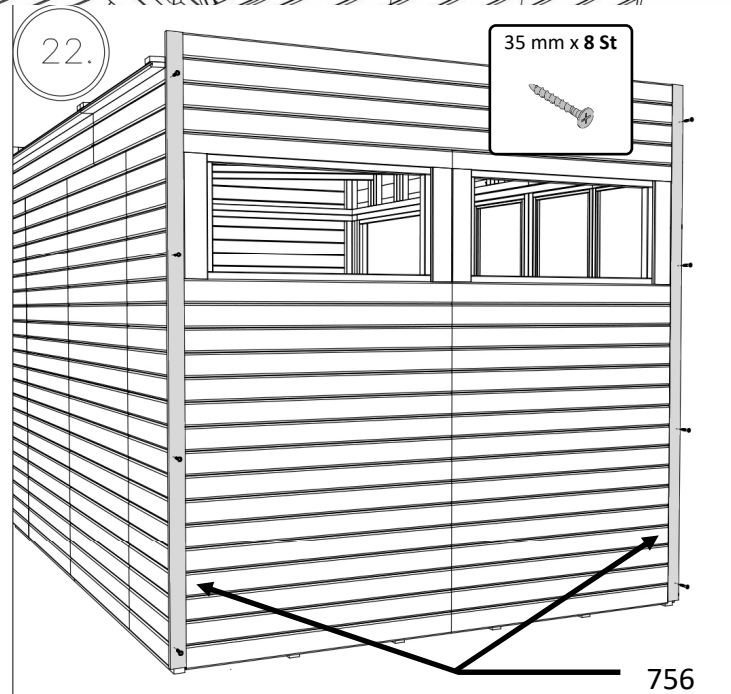
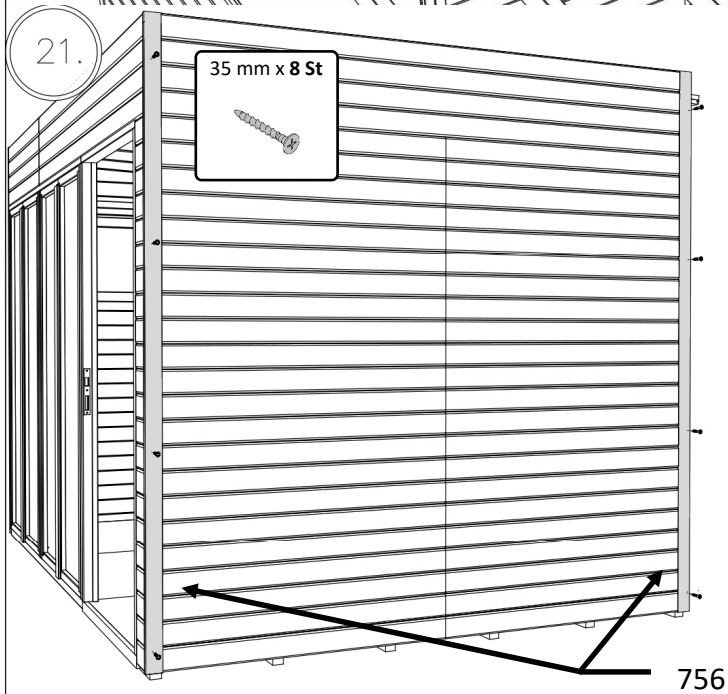
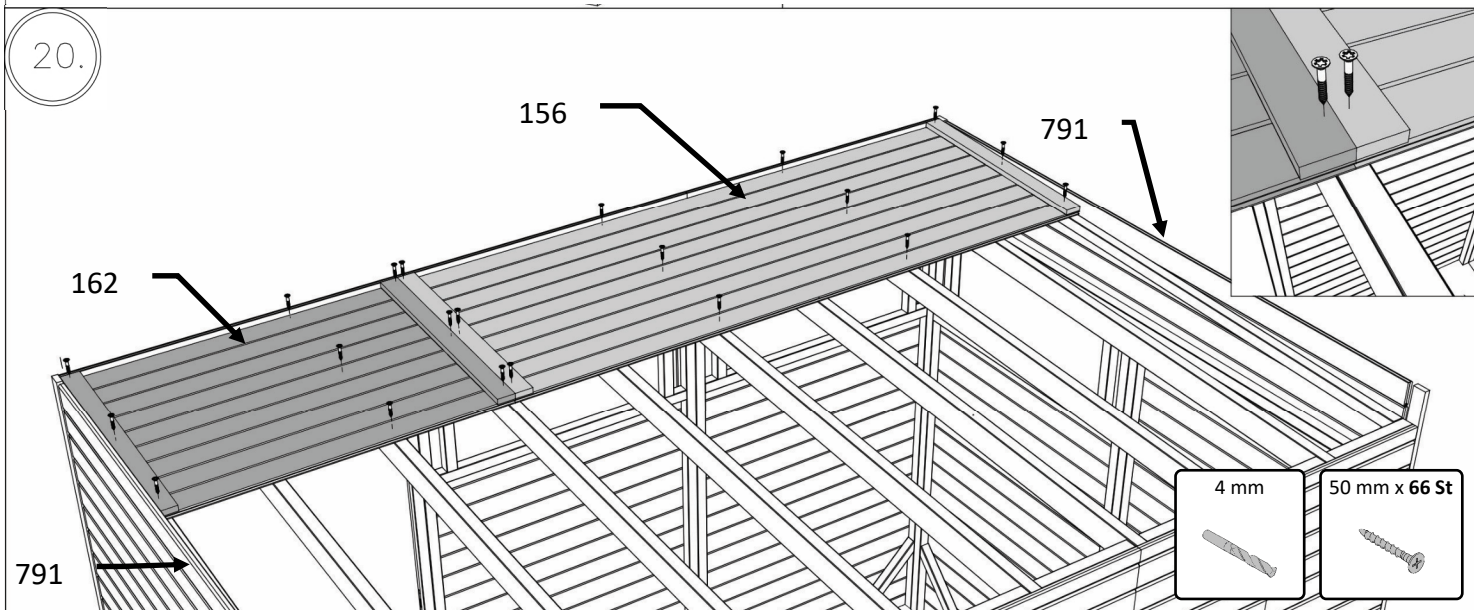

# OFCU3(NF/GR/AN)

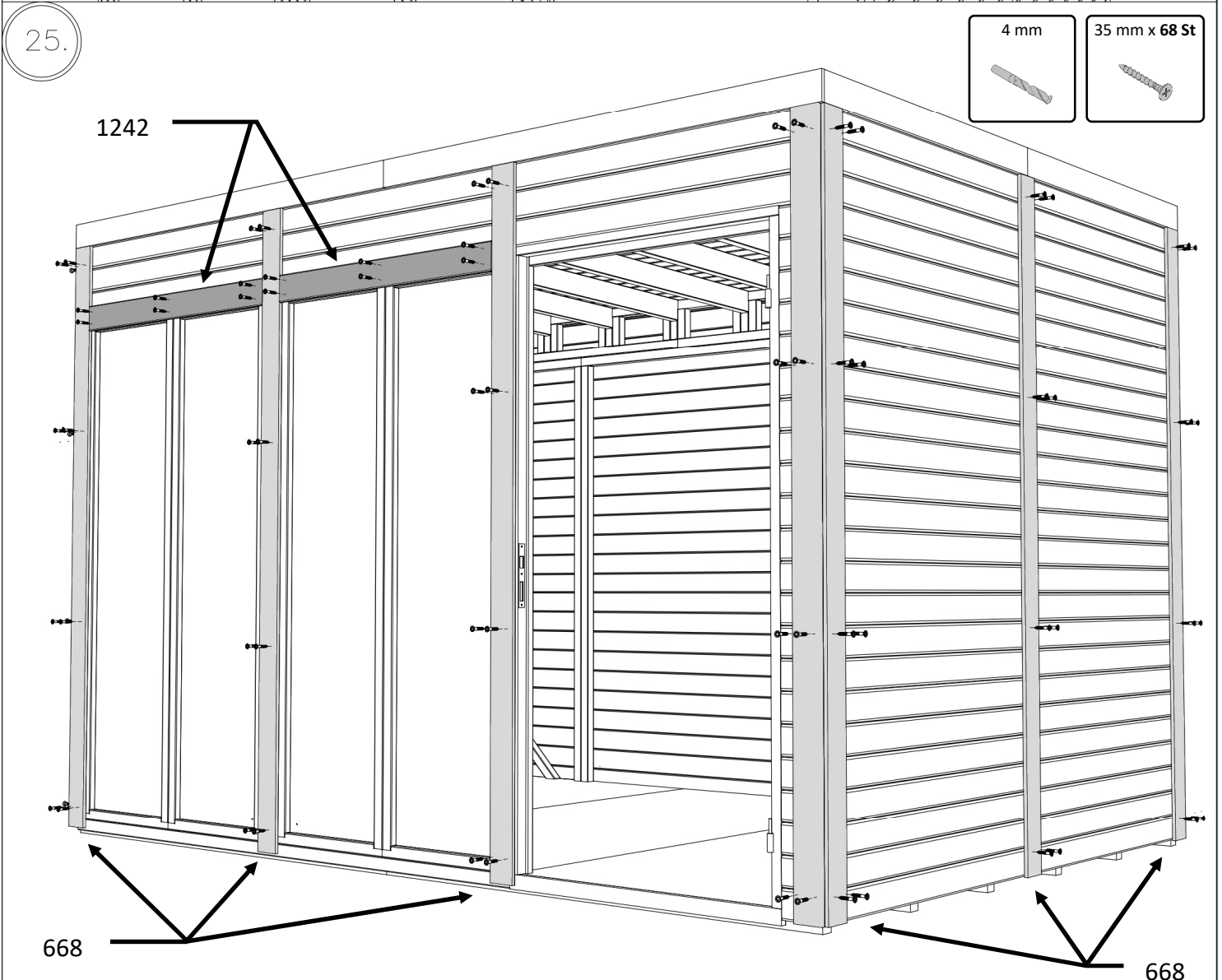
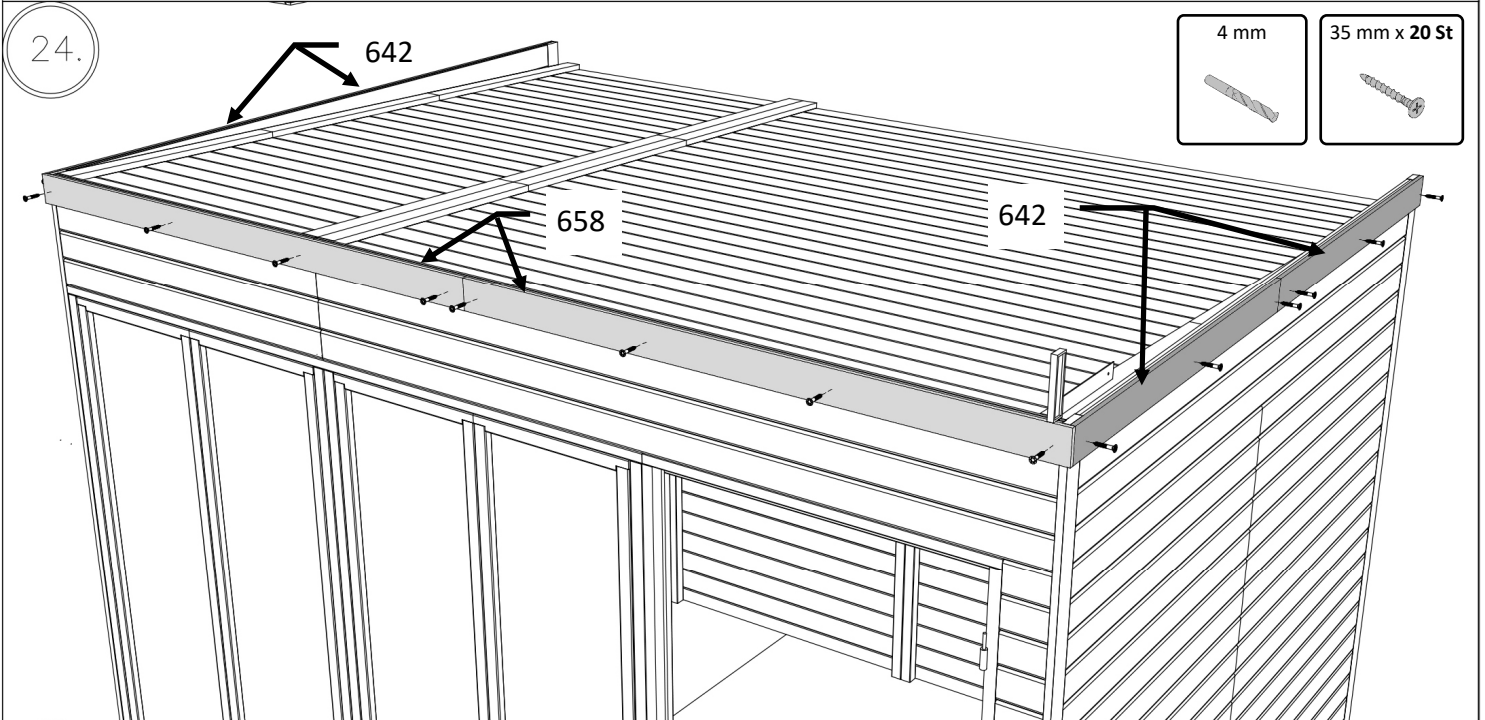

# OFCU3(NF/GR/AN)

26.

35 mm x 23 St



4 mm

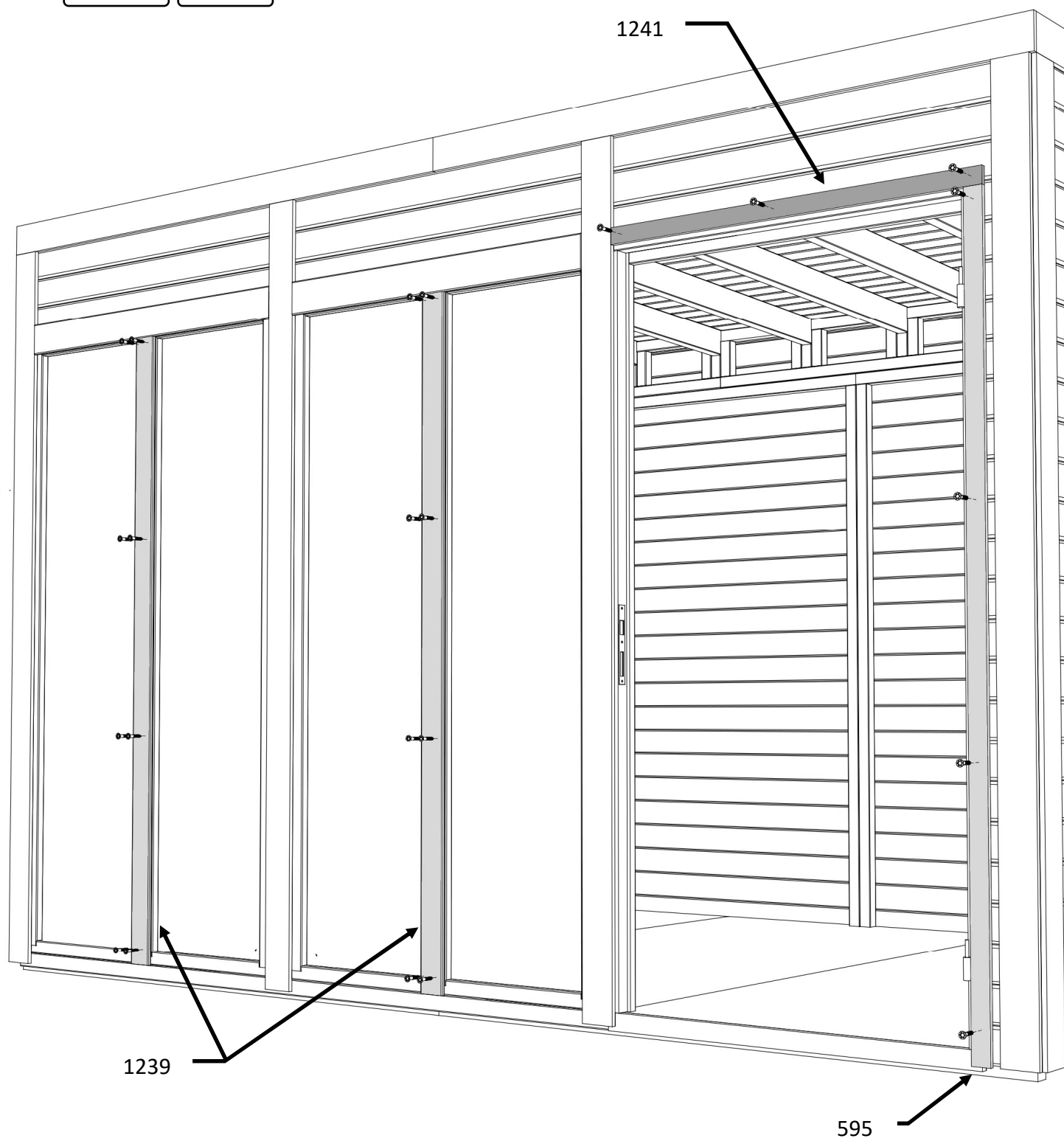

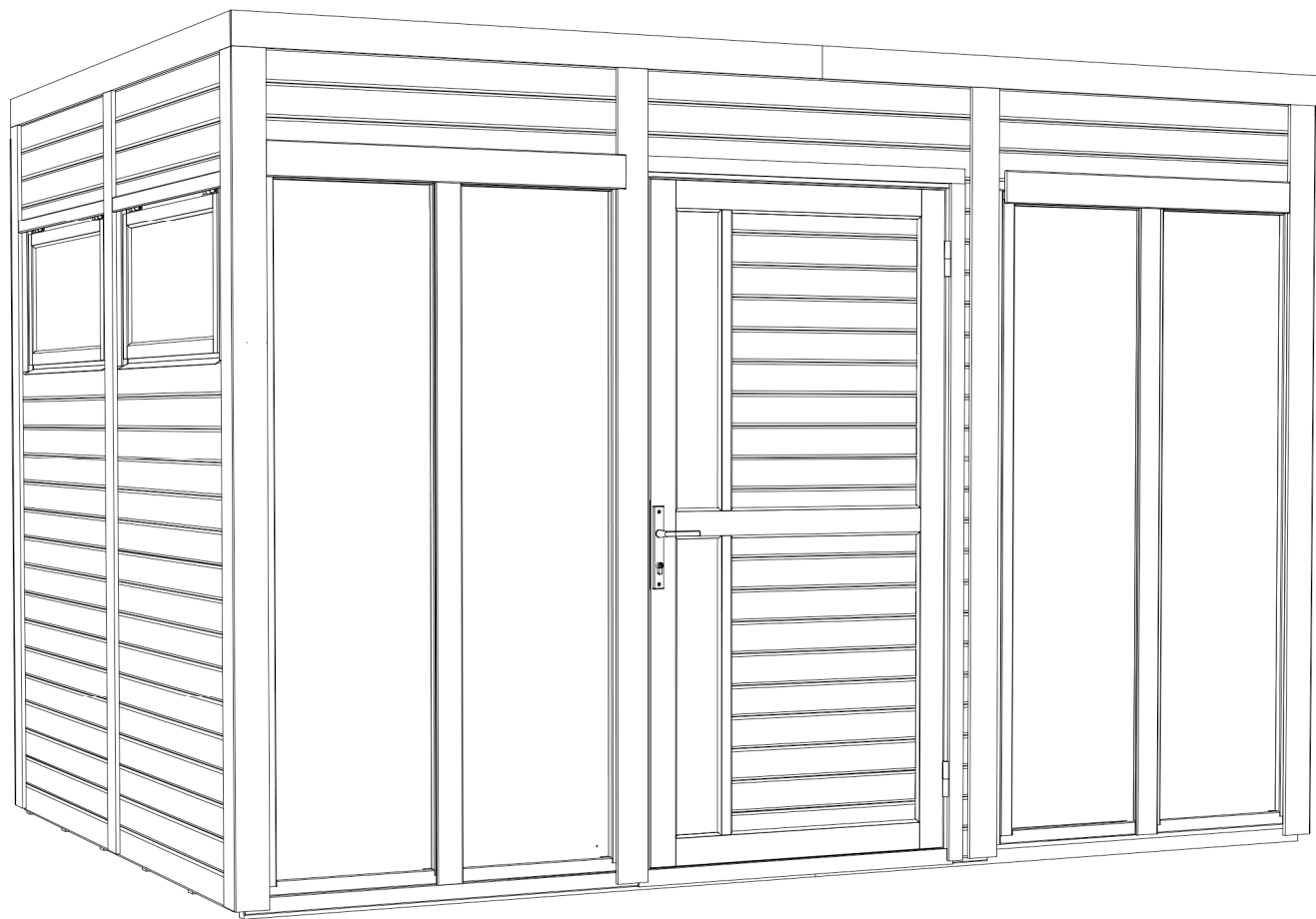

Step 7

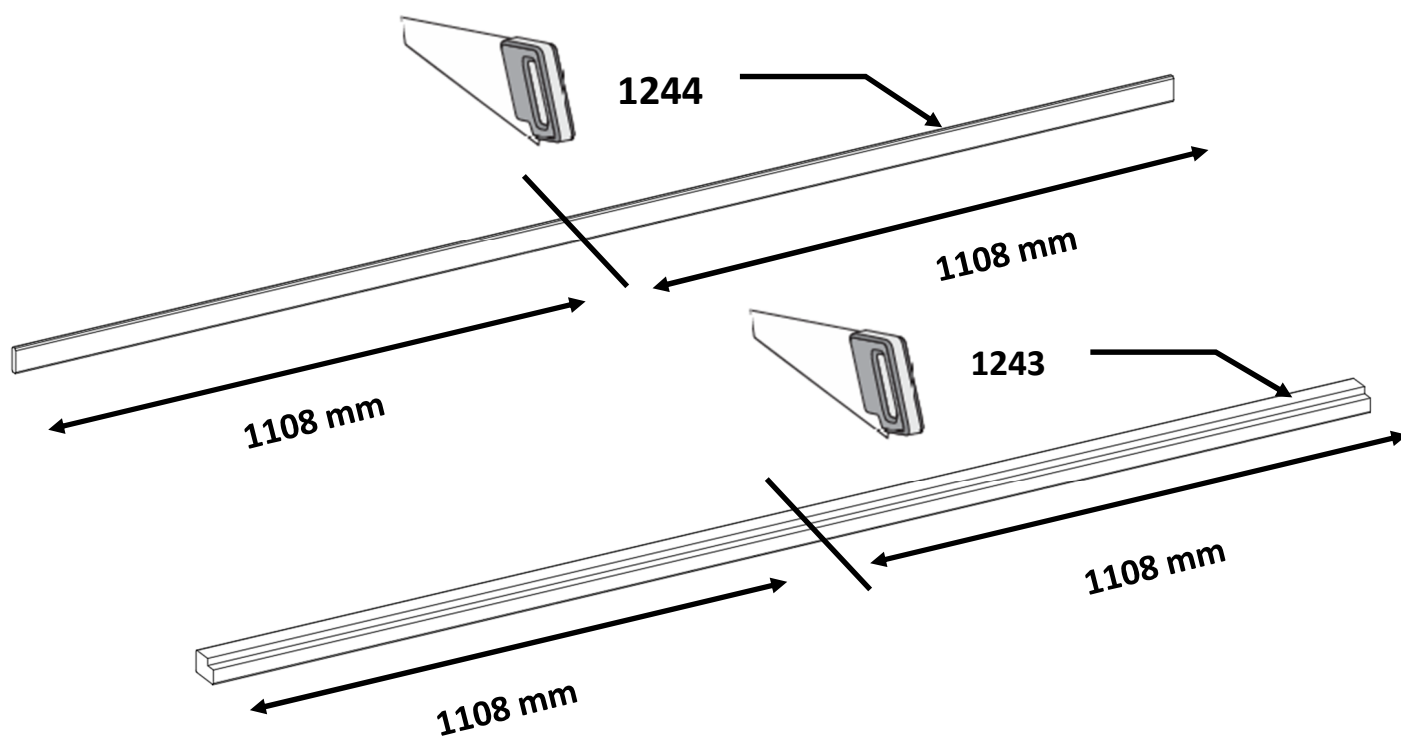

# OFCU3(NF/GR/AN)

Version B

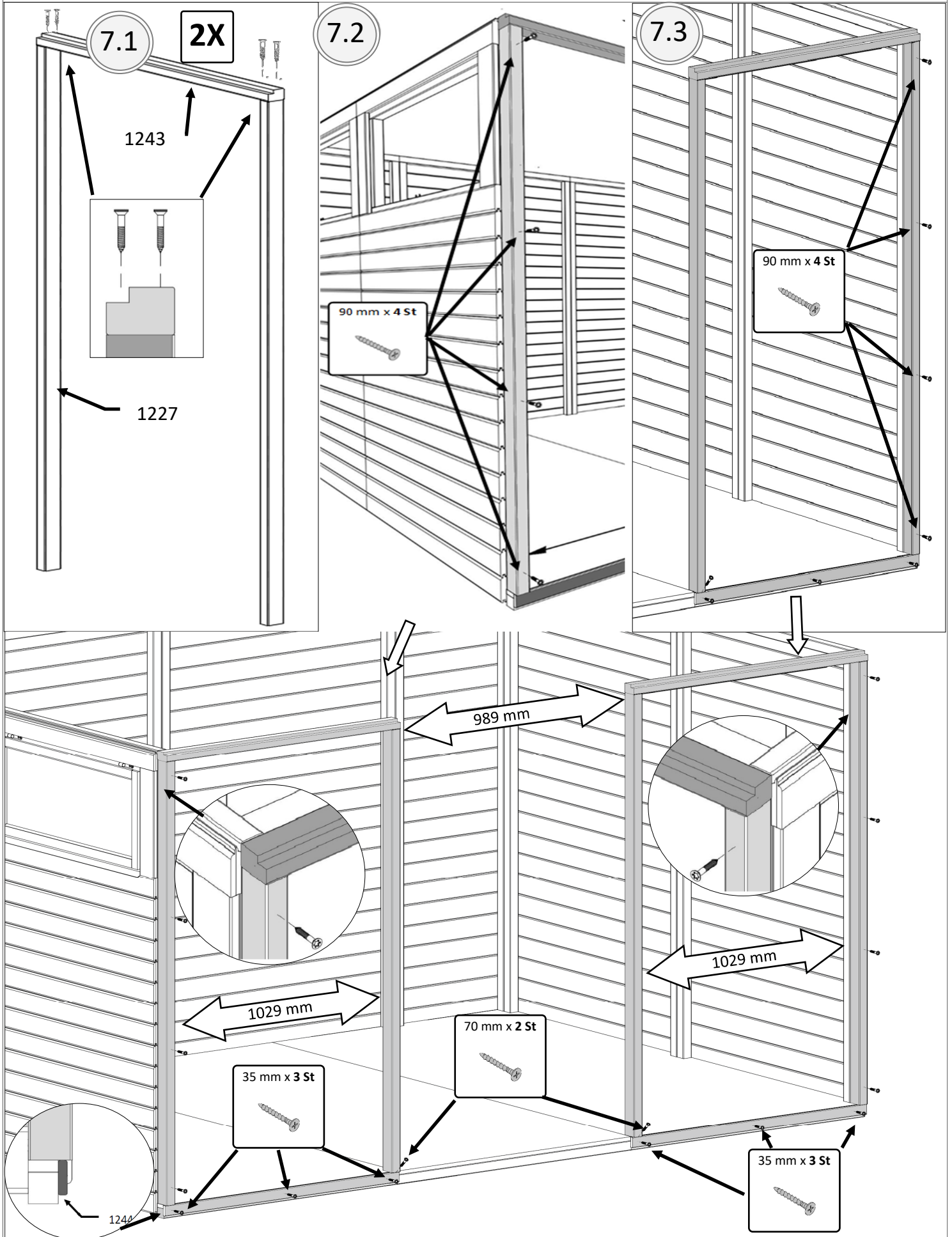

7.4

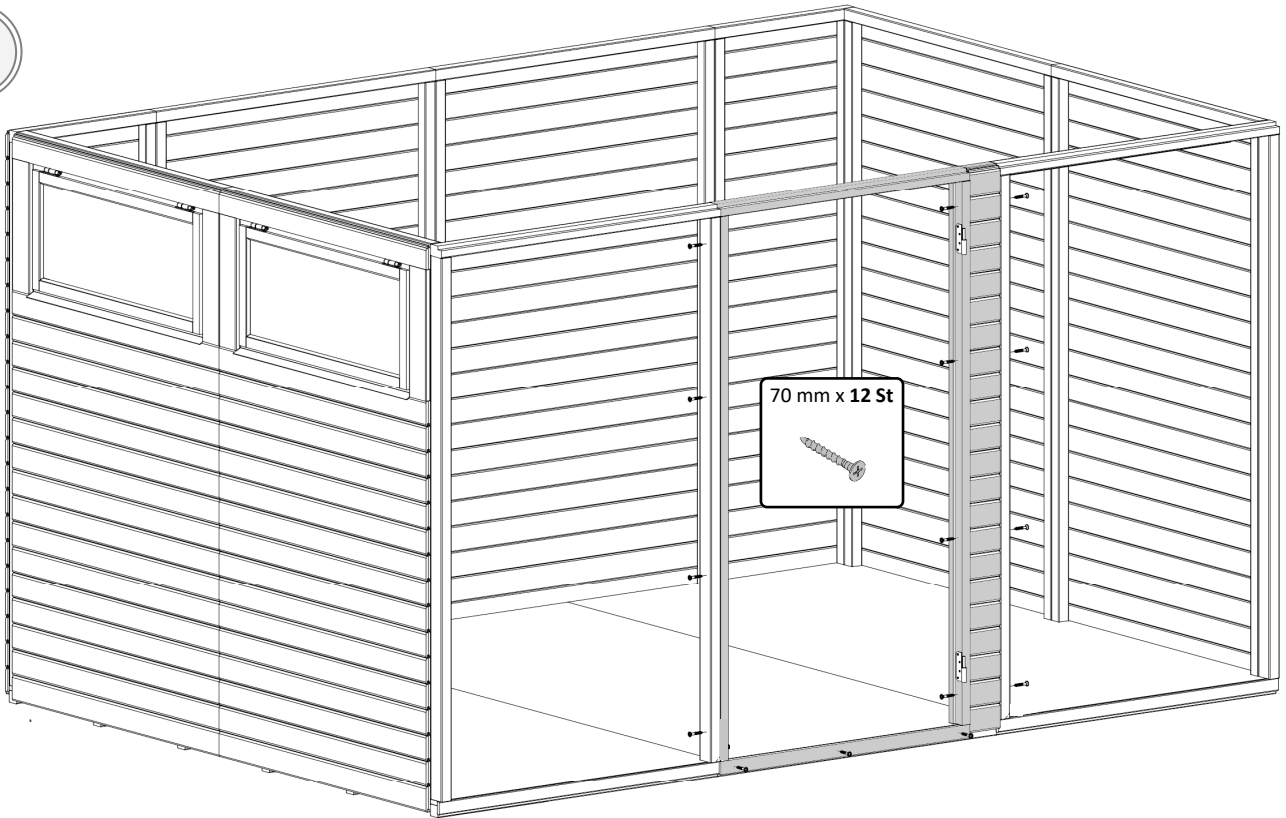

7.5

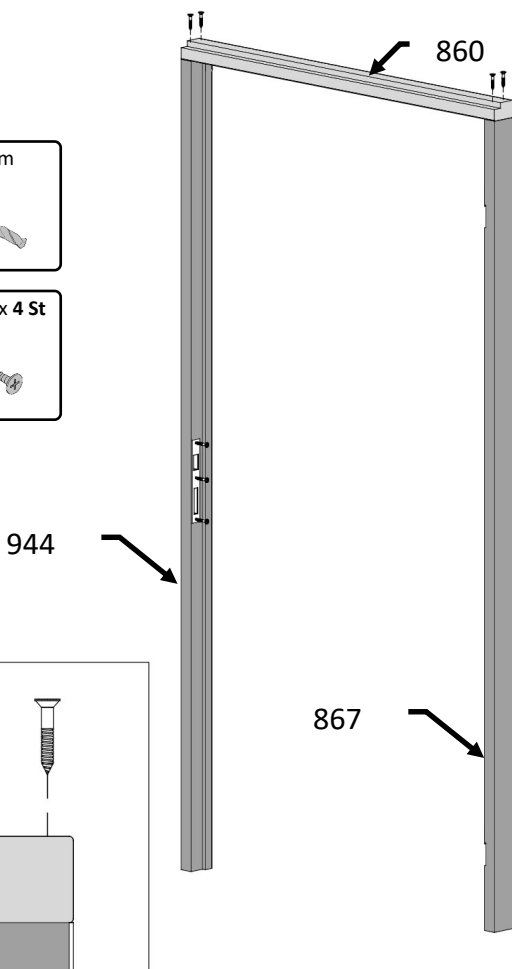
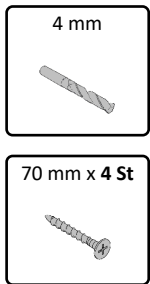

7.6

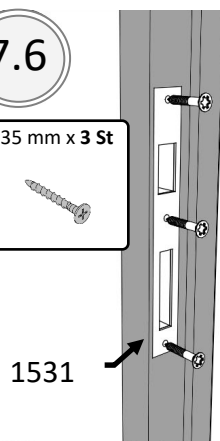
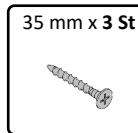

7.7

2X

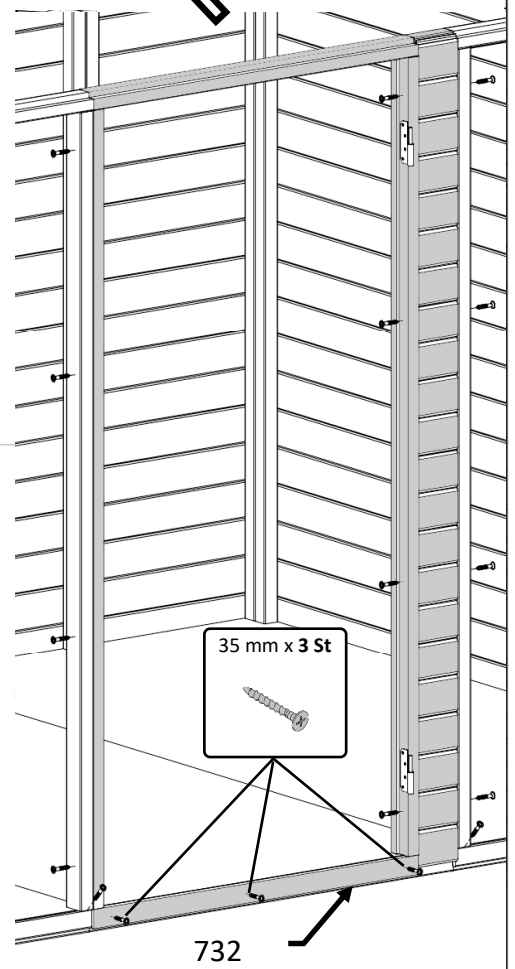
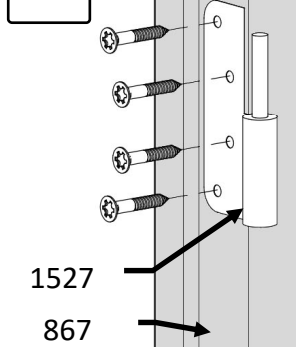

8.

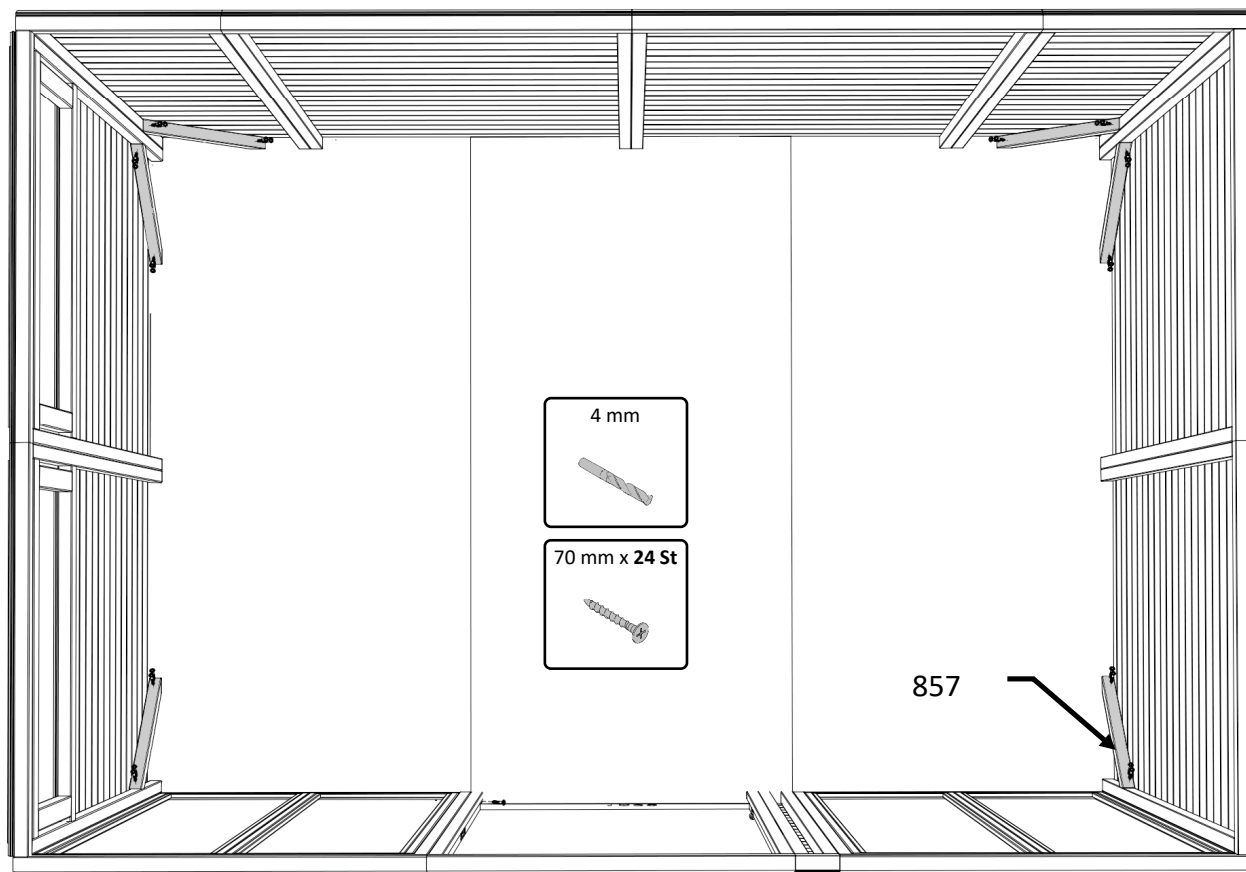

8.1

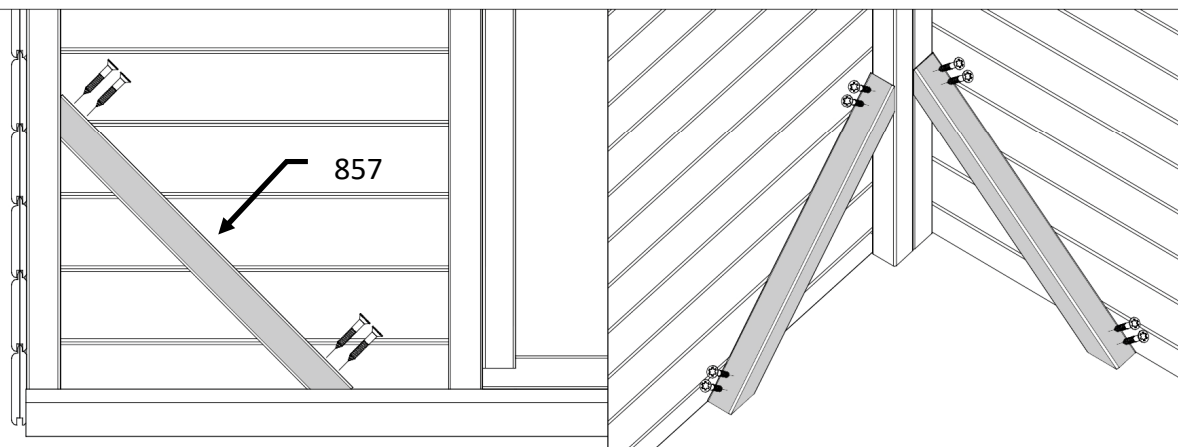

# OFCU3(NF/GR/AN)

Version B

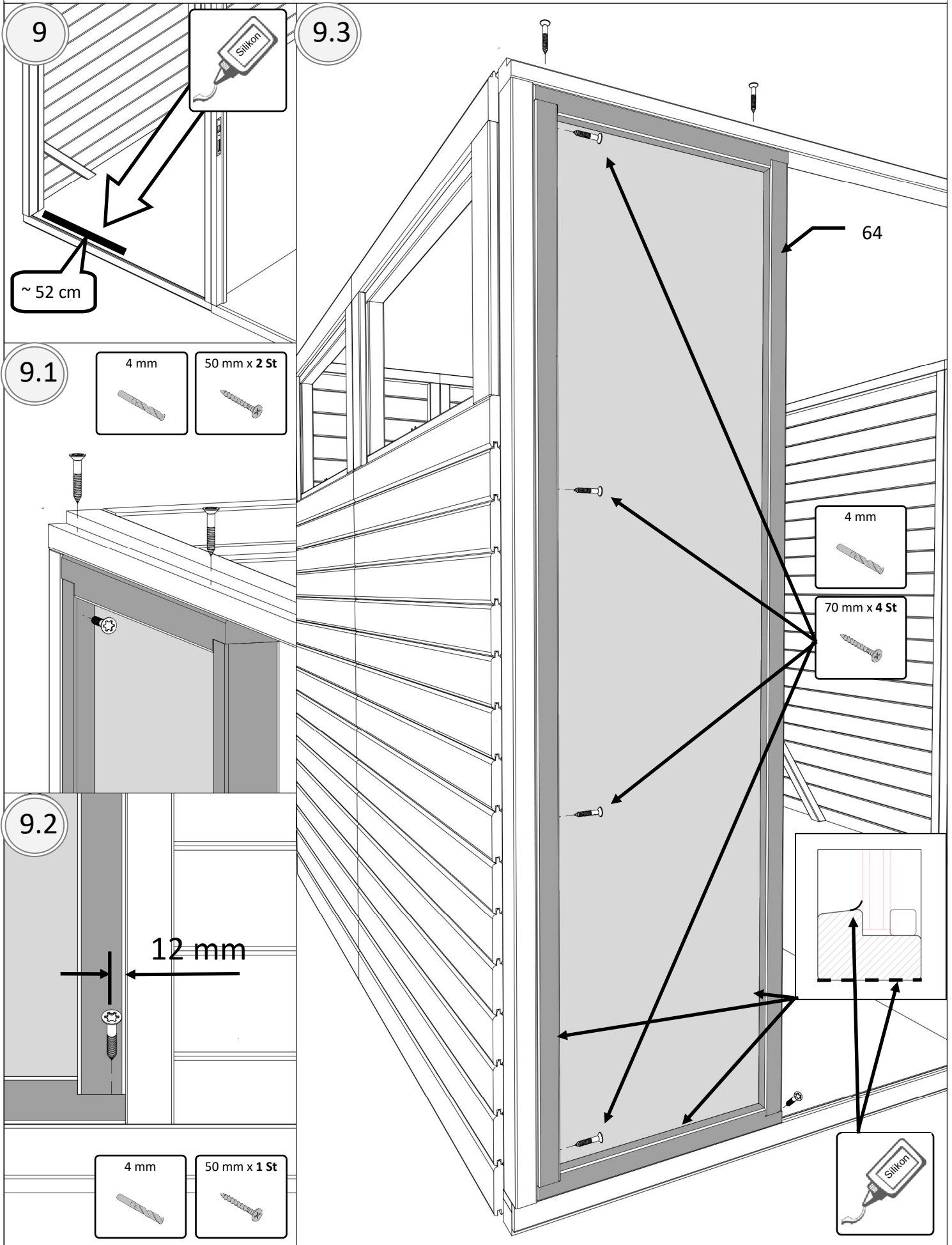

# OFCU3(NF/GR/AN)

Version B

10

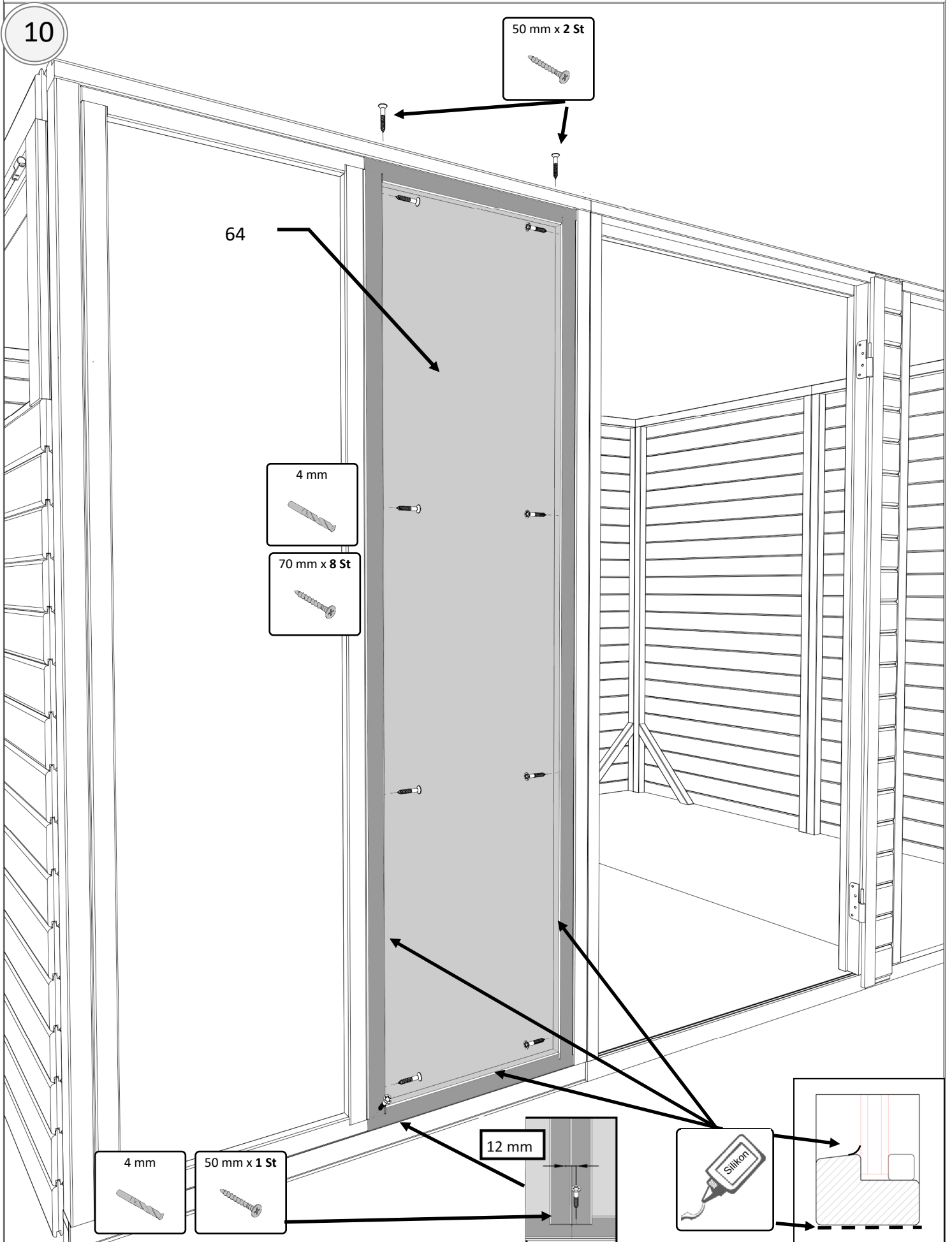

# OFCU3(NF/GR/AN)

Version B

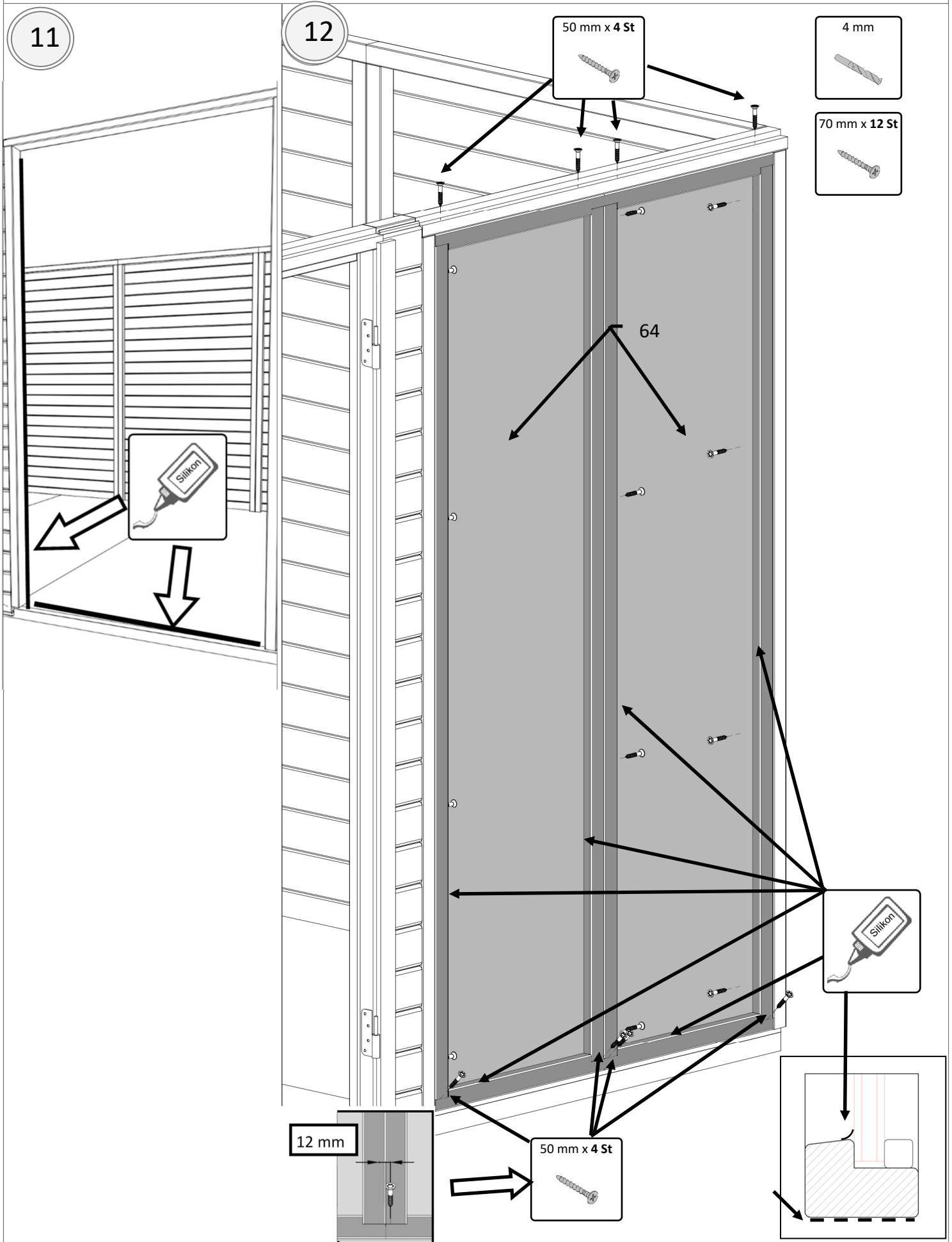

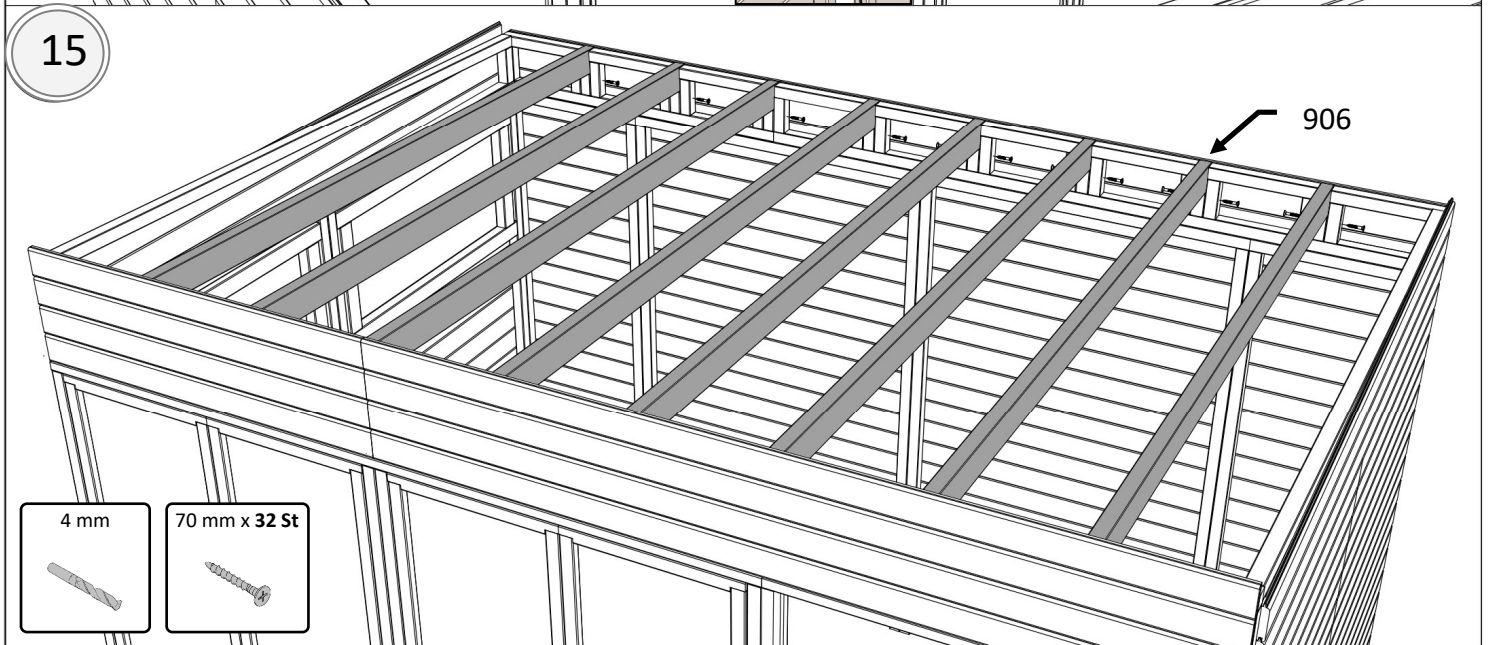
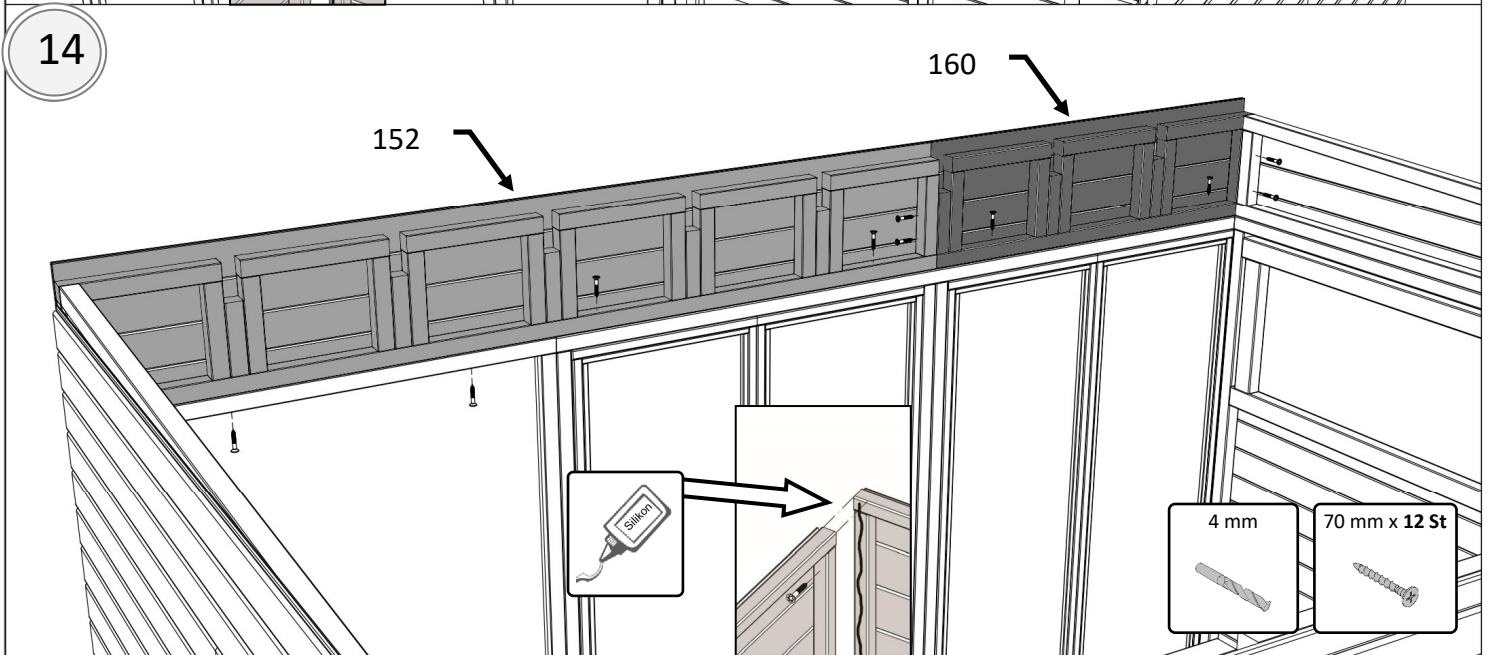
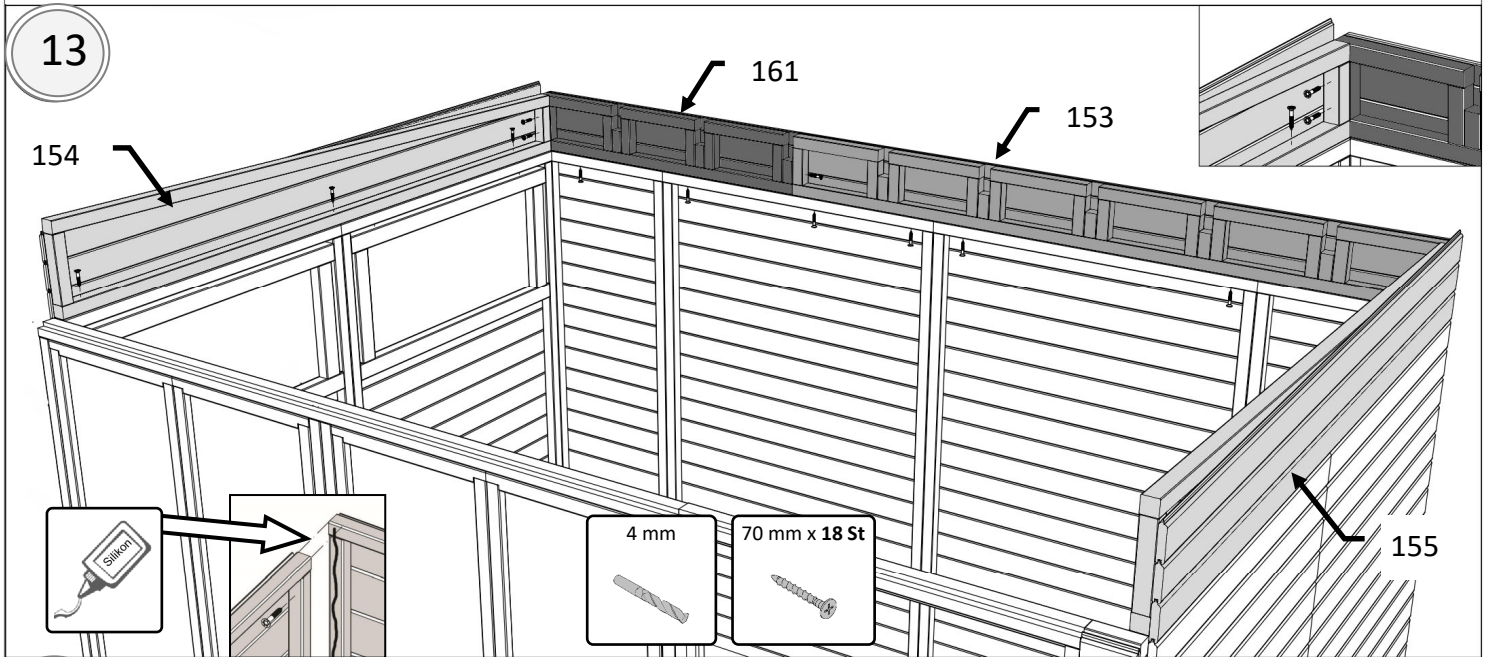

# OFCU3(NF/GR/AN)

Version B

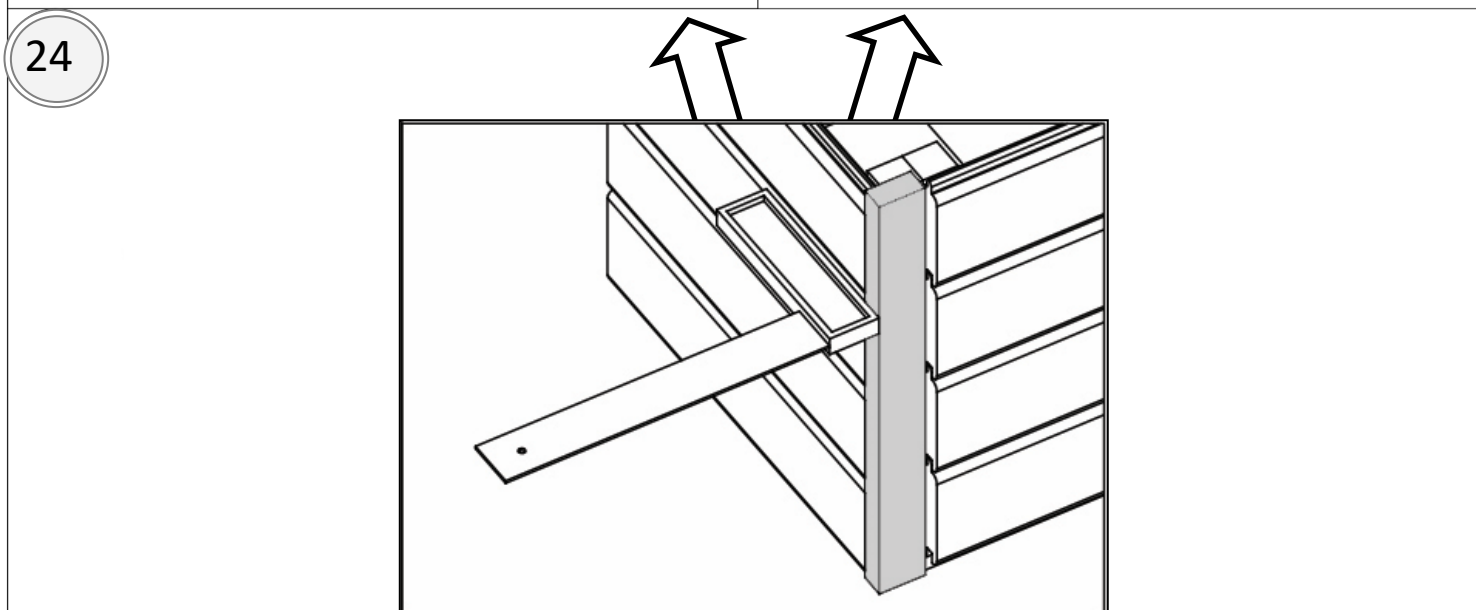
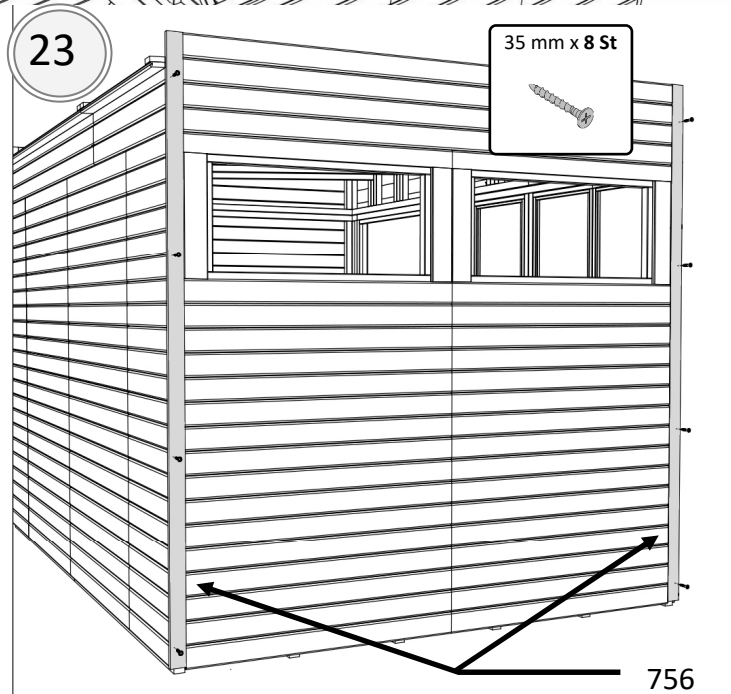
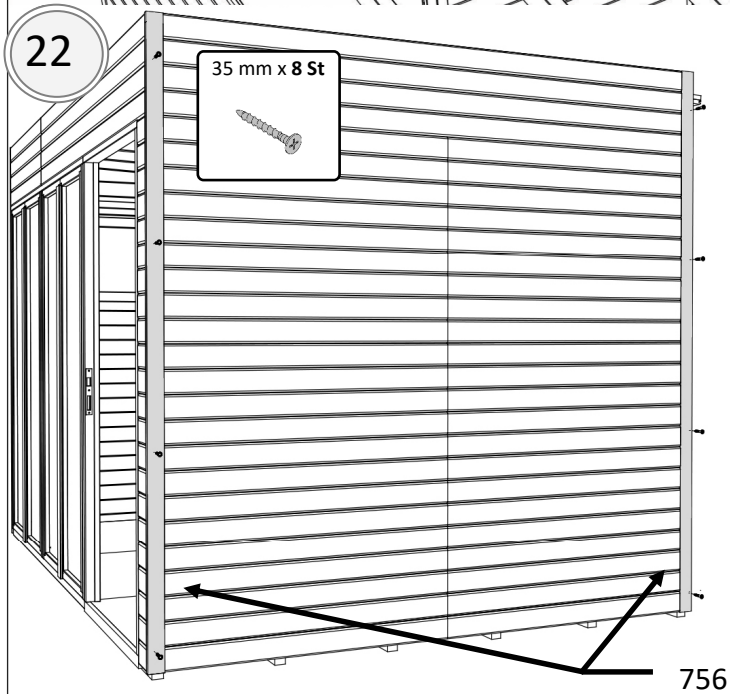
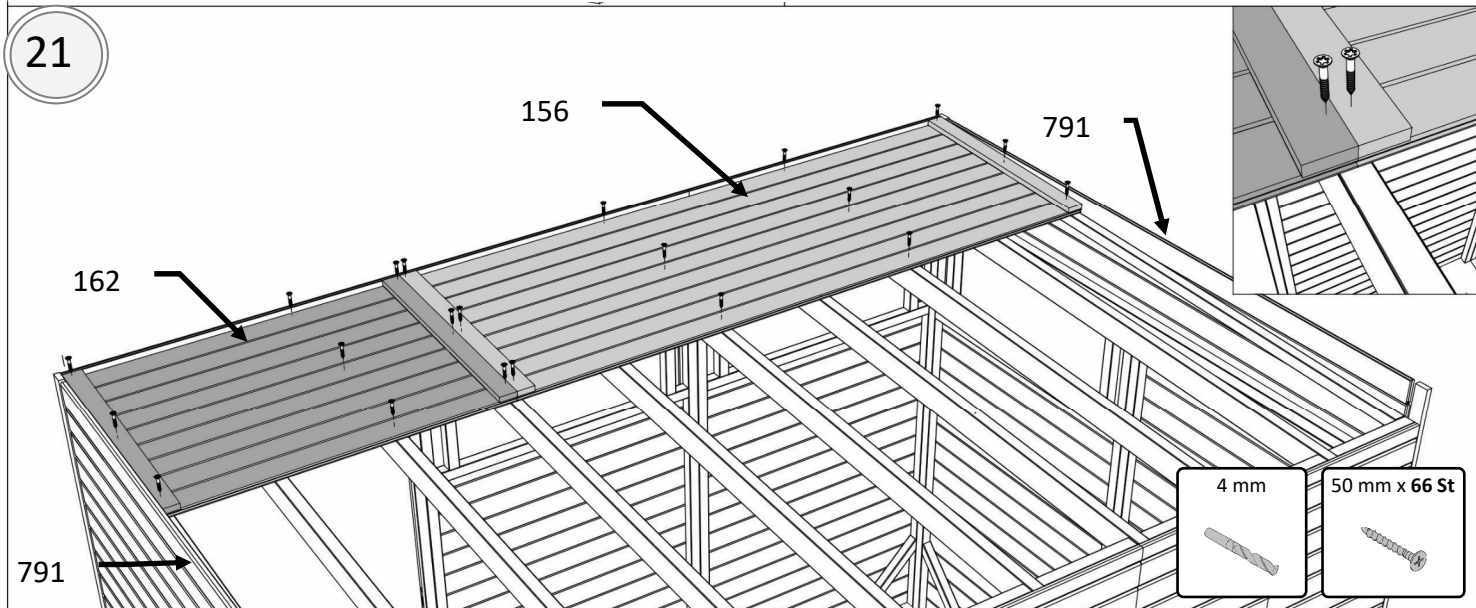

# OFCU3(NF/GR/AN)

Version B

24

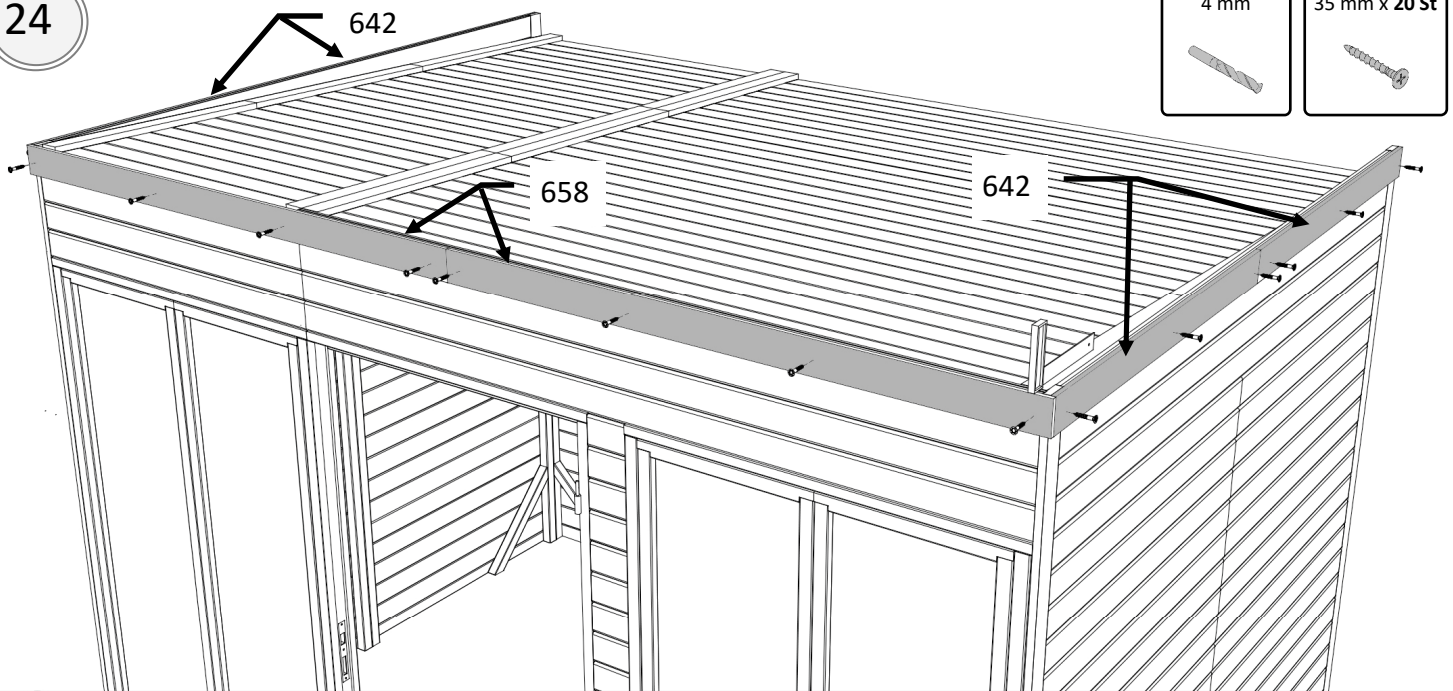

25

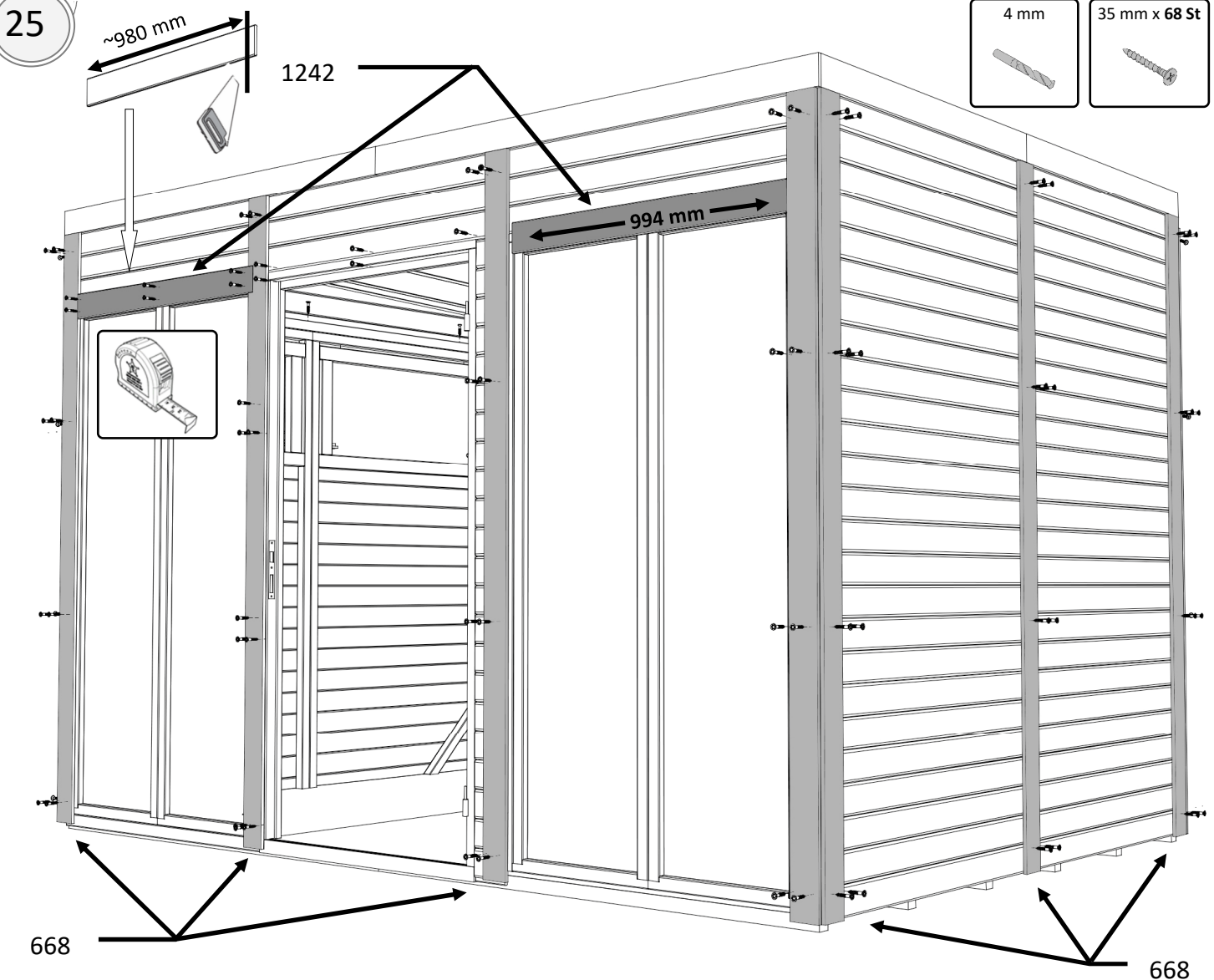

26

35 mm x 23 St



4 mm

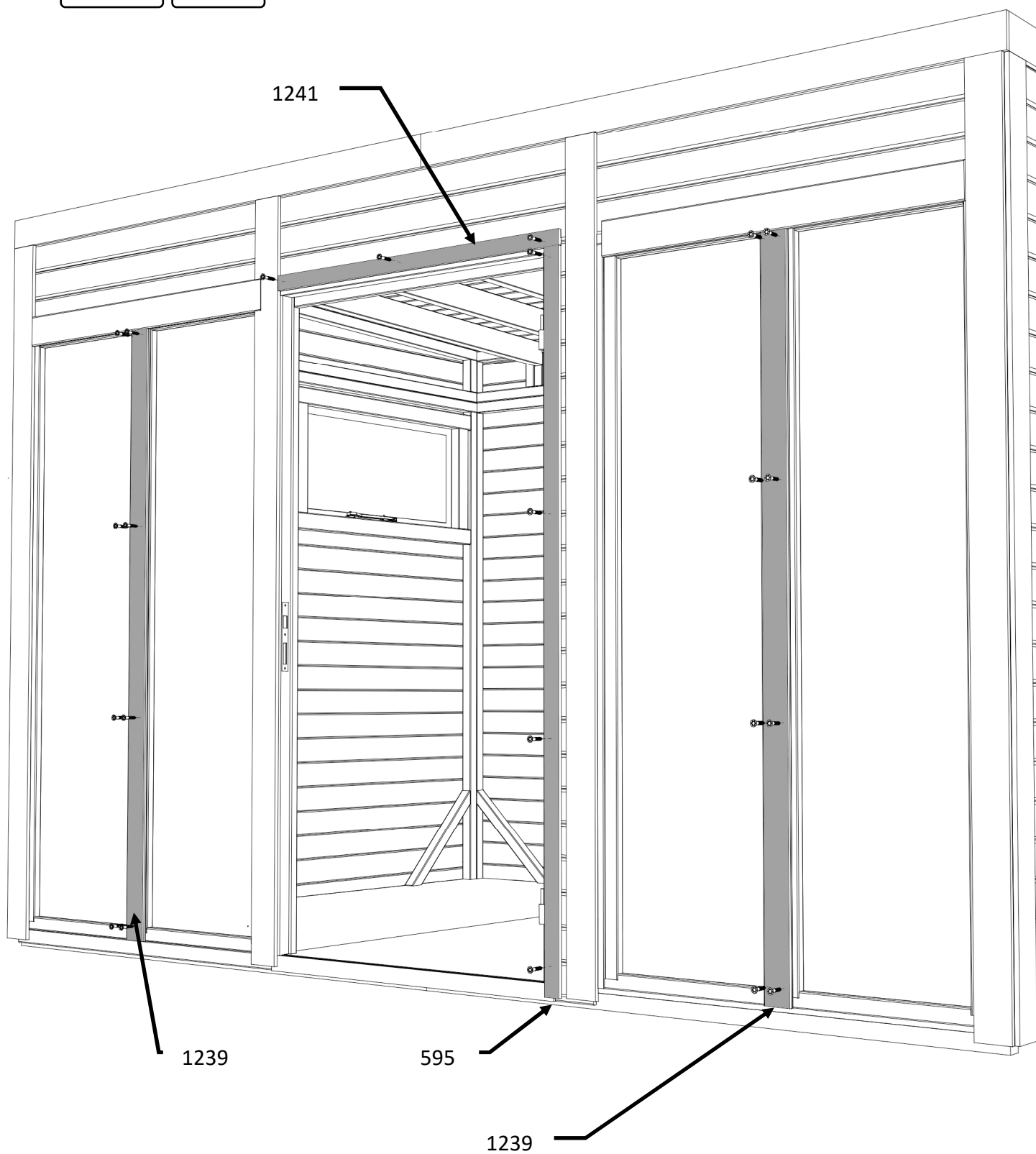

# OFCU3(NF/GR/AN)

27.

4 mm



35 mm x 64 St

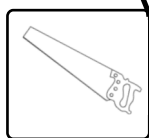
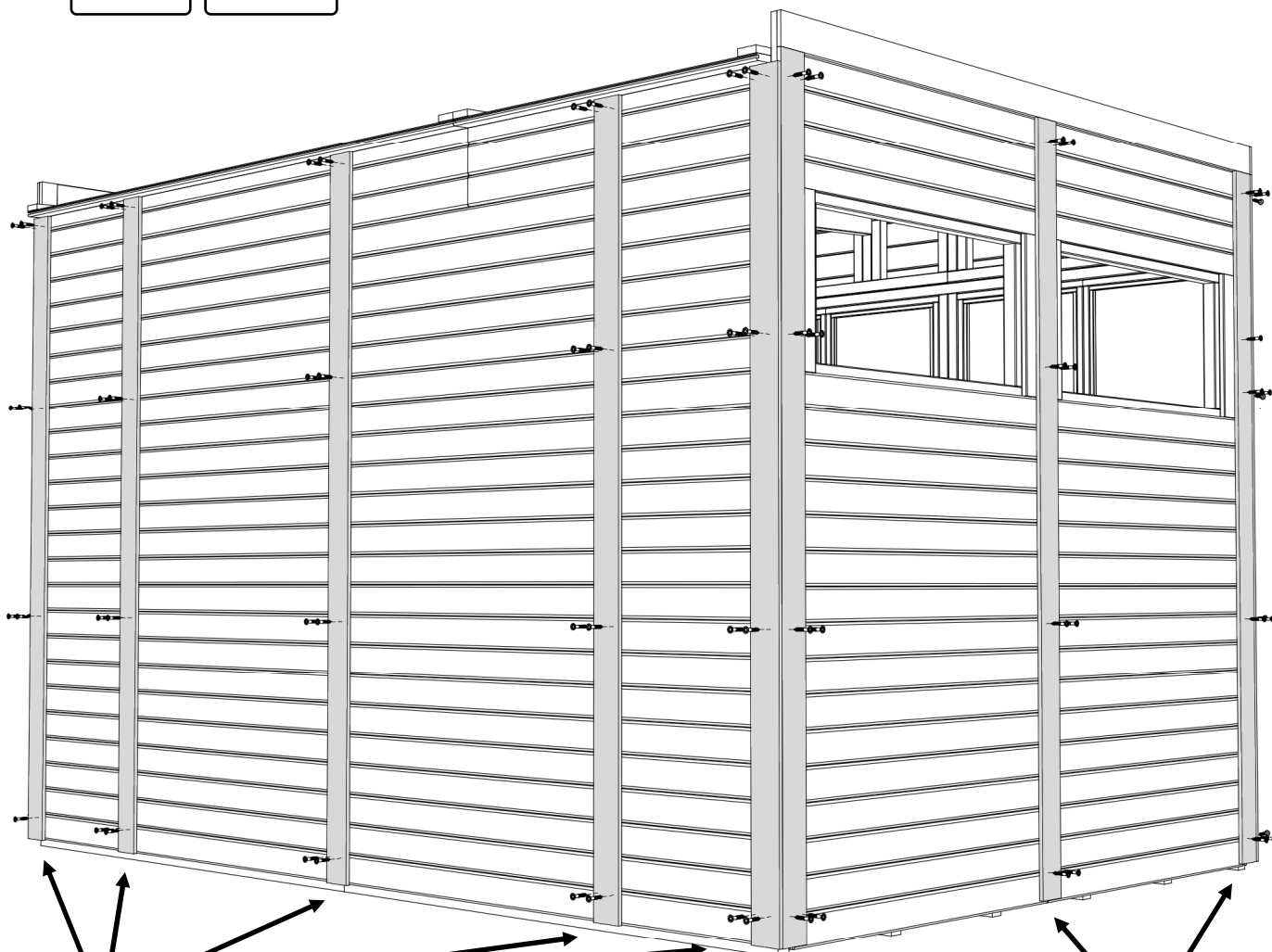

668

28.

707

4 mm



35 mm x 3 St

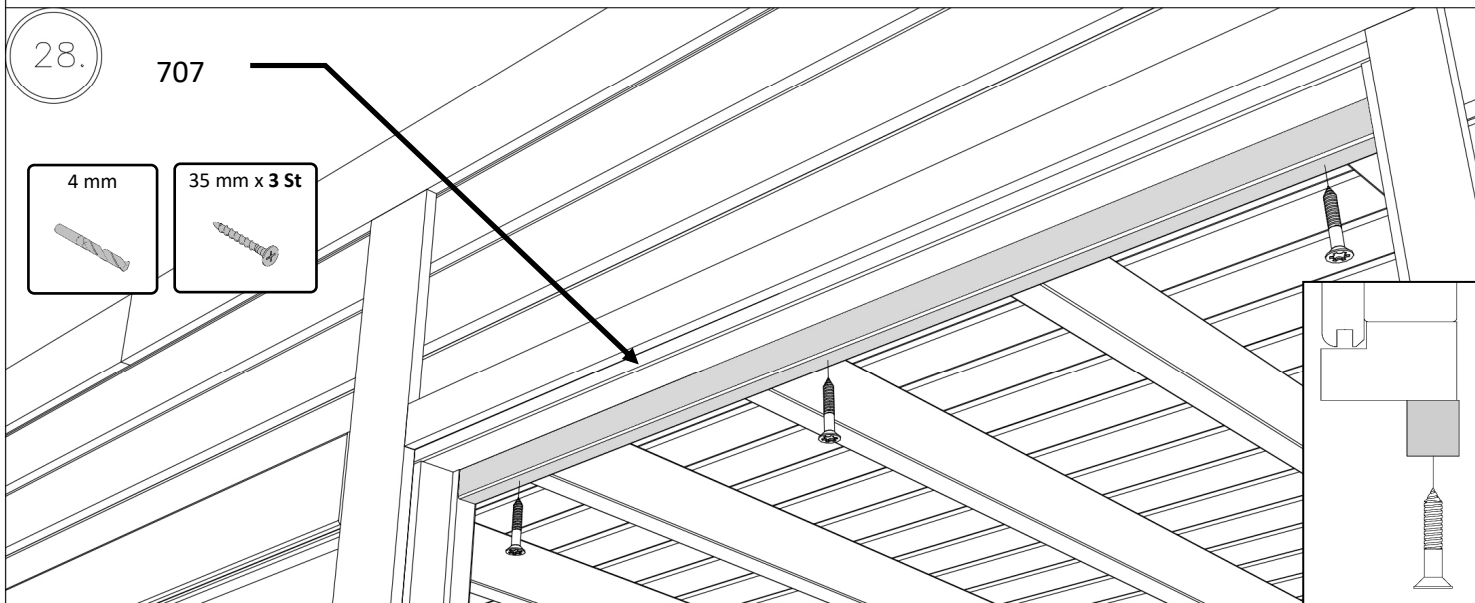

# NB! OFCU3GR/AN!!!!

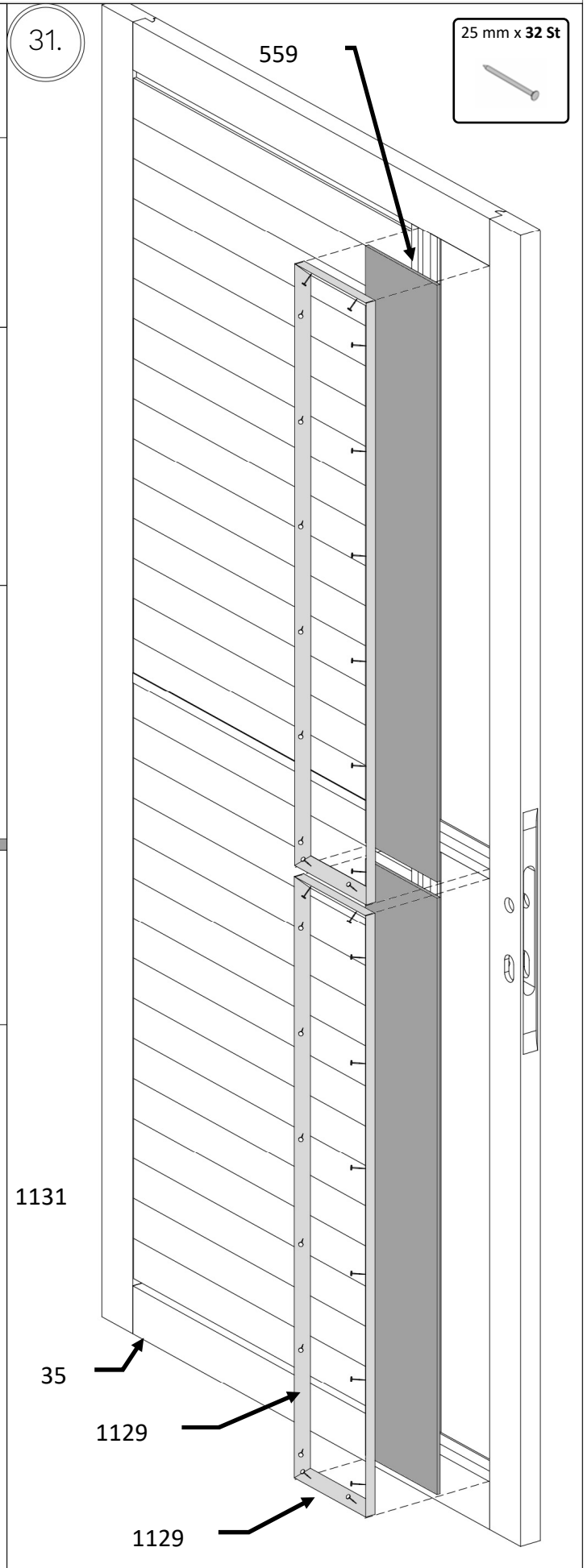
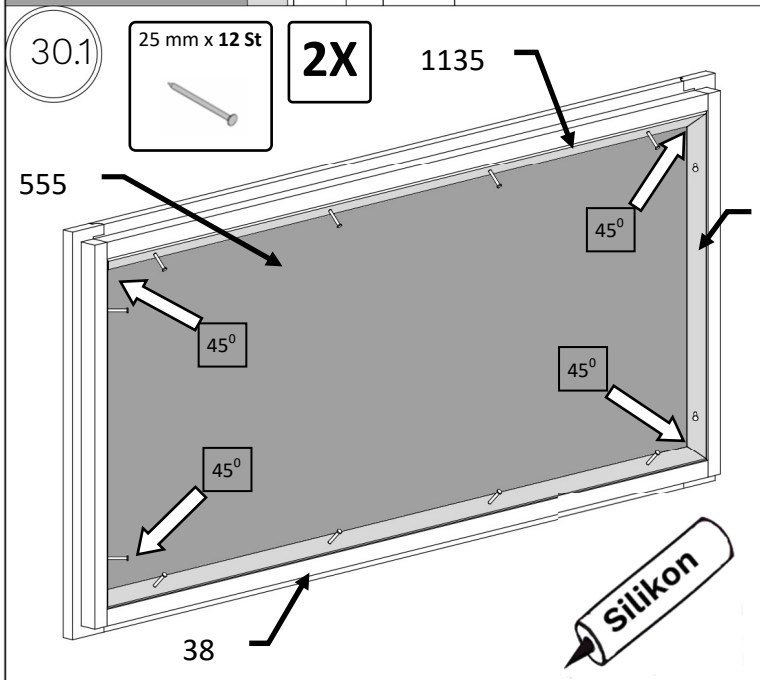
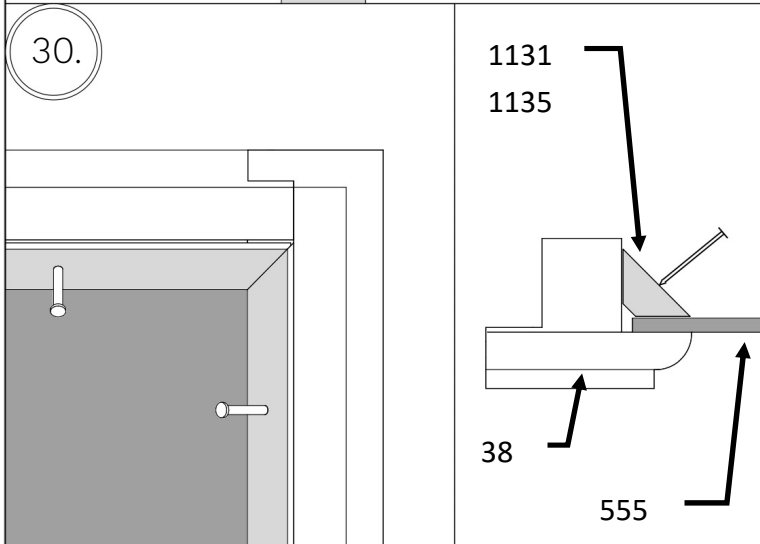
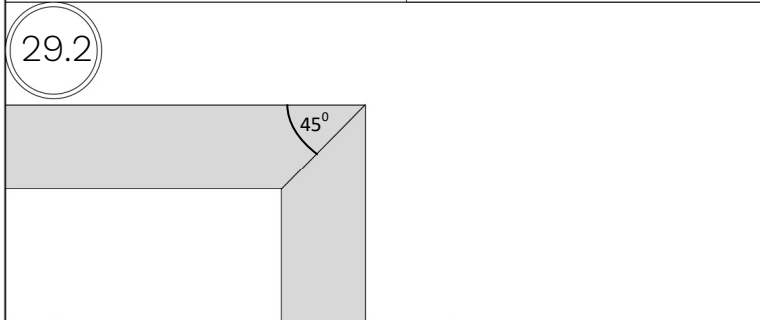
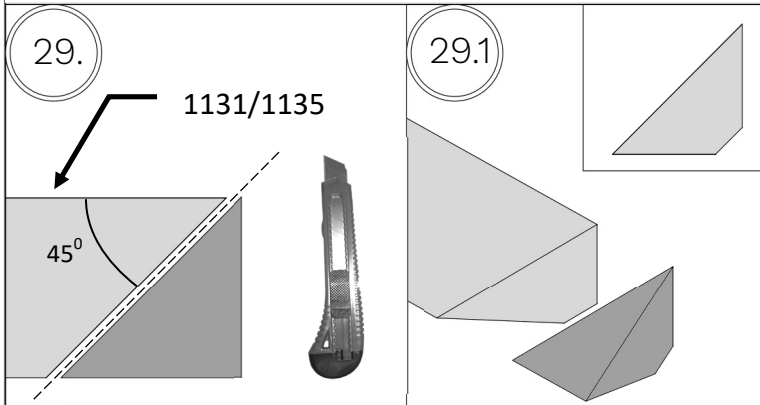

# OFCU3(NF/GR/AN)

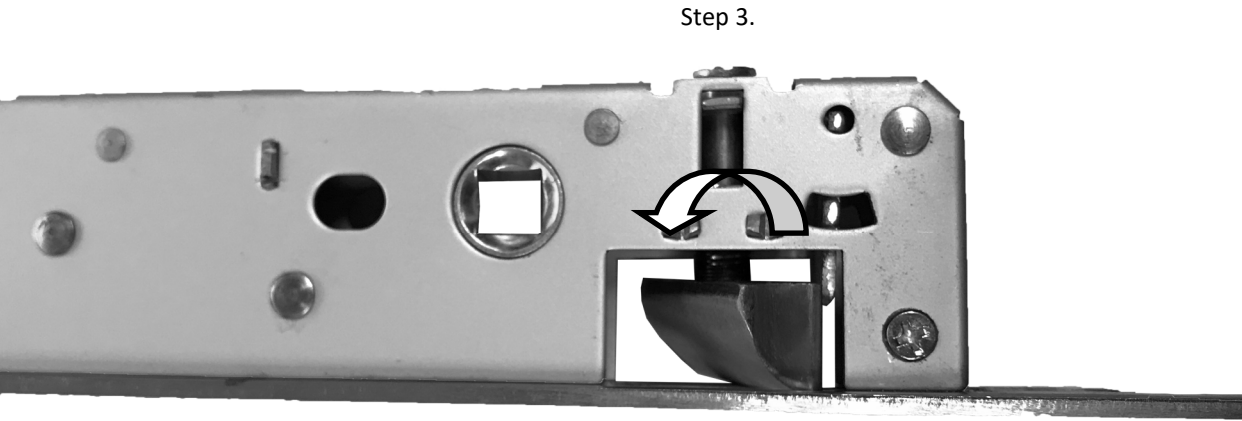
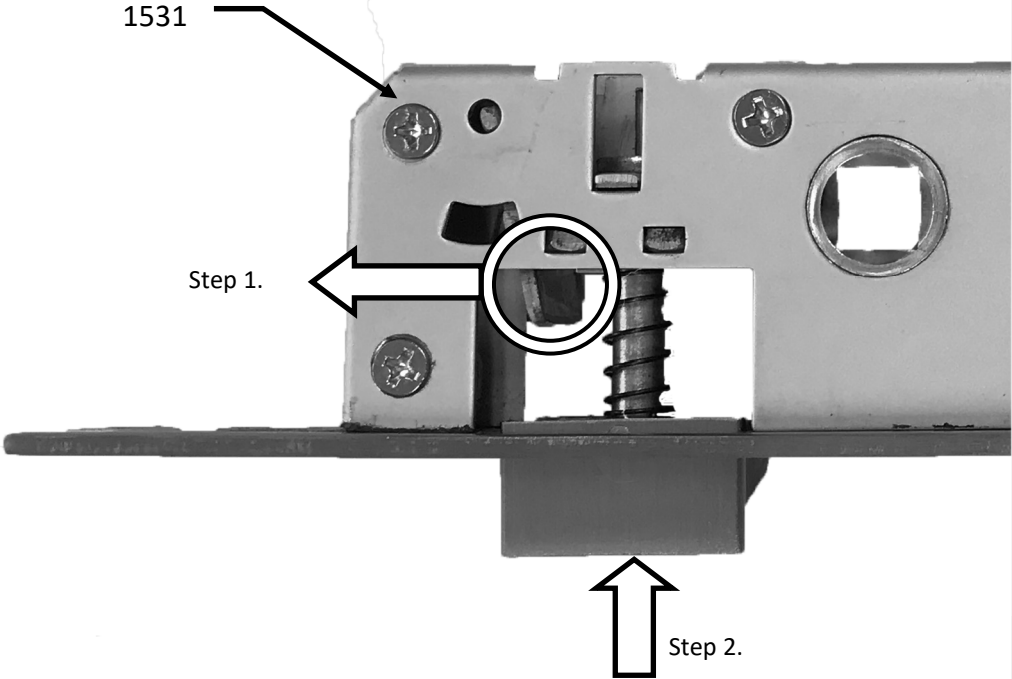

# OFCU3(NF/GR/AN)

32..

NB! OFCU3NF!!!!

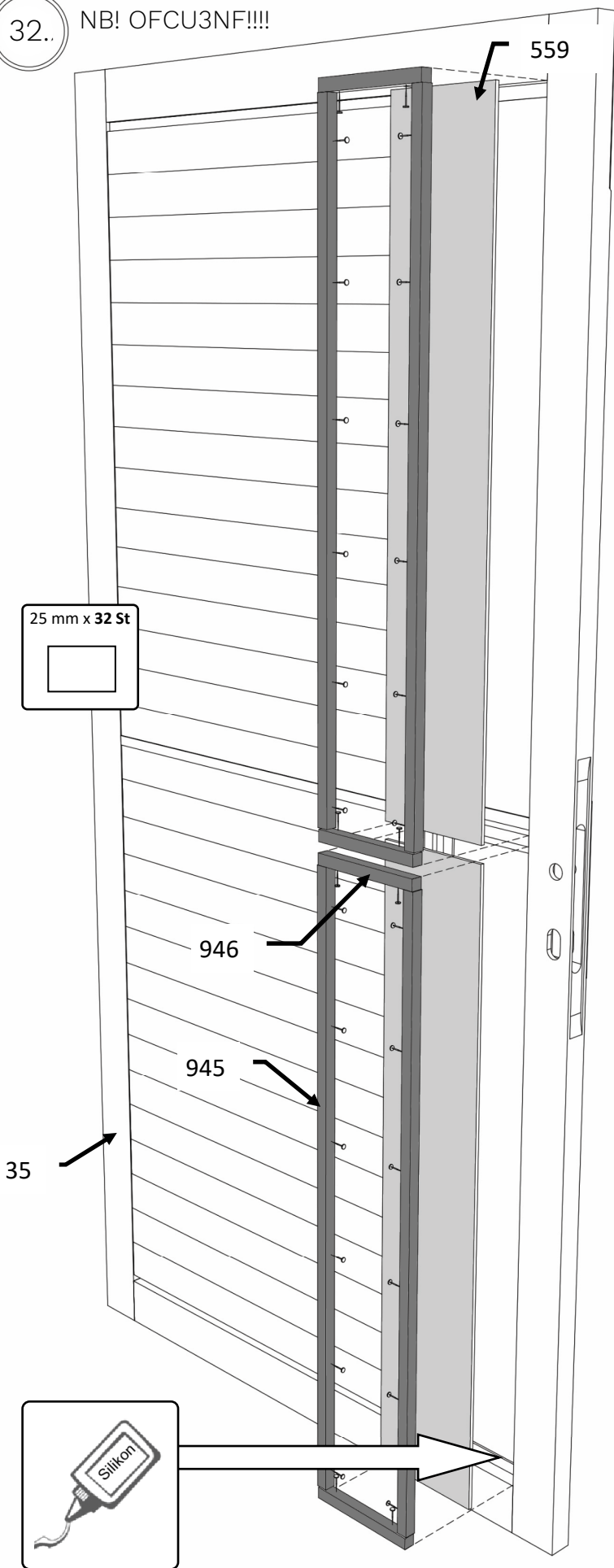

50 mm x 4 St



2X

1527

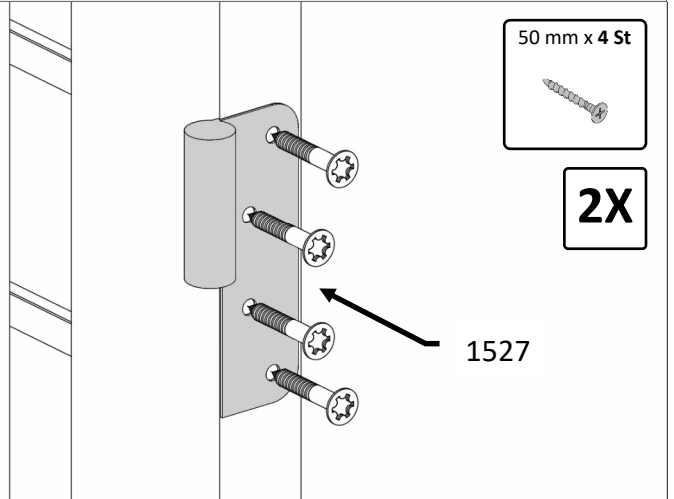

35 mm x 6 St



1531

1554

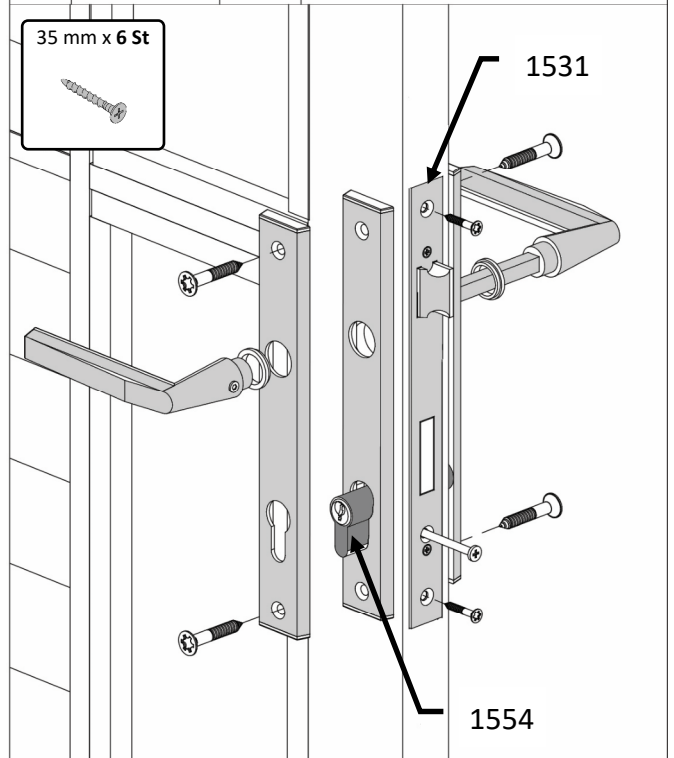

33.



# OFCU3(NF/GR/AN)

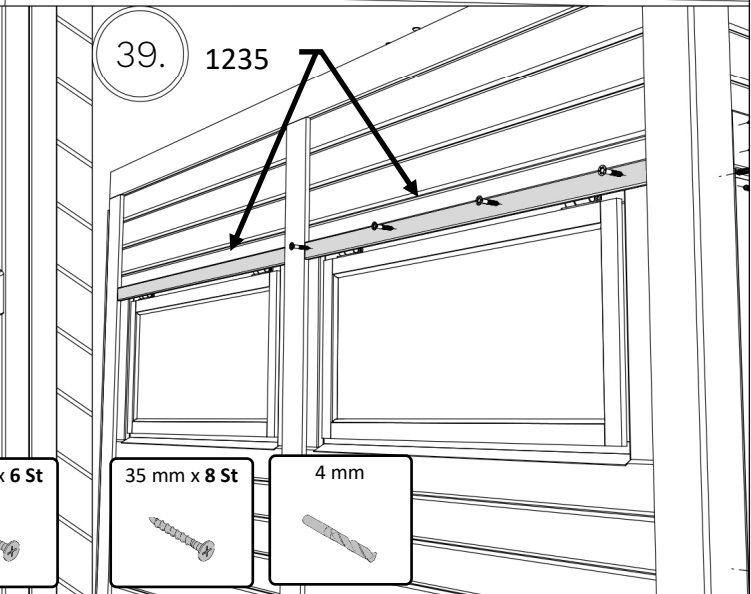
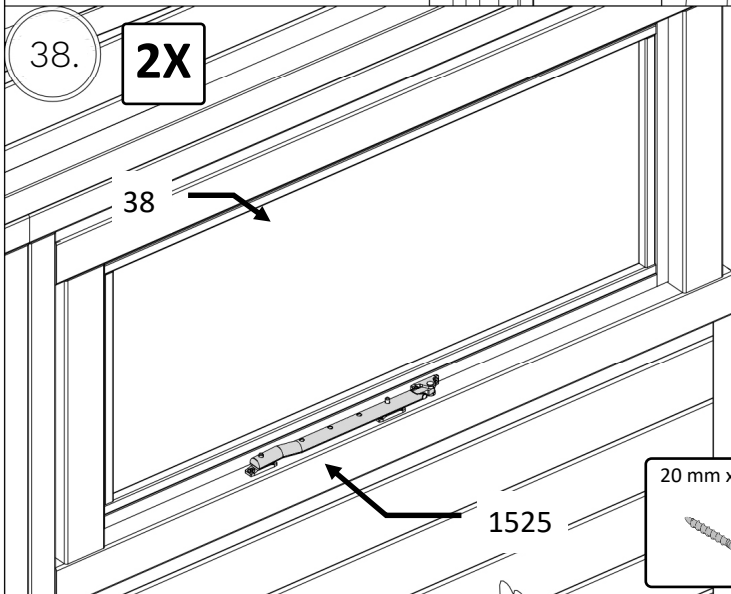
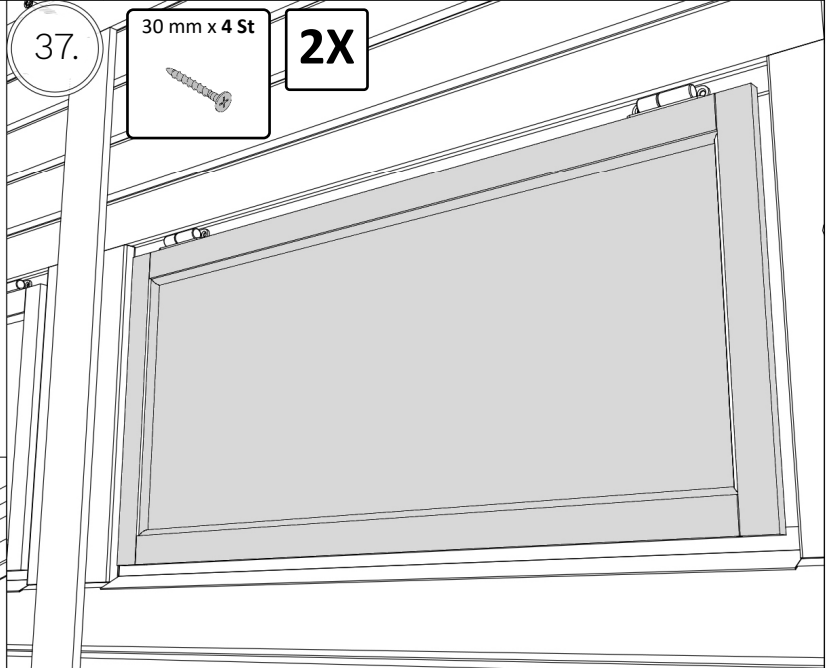
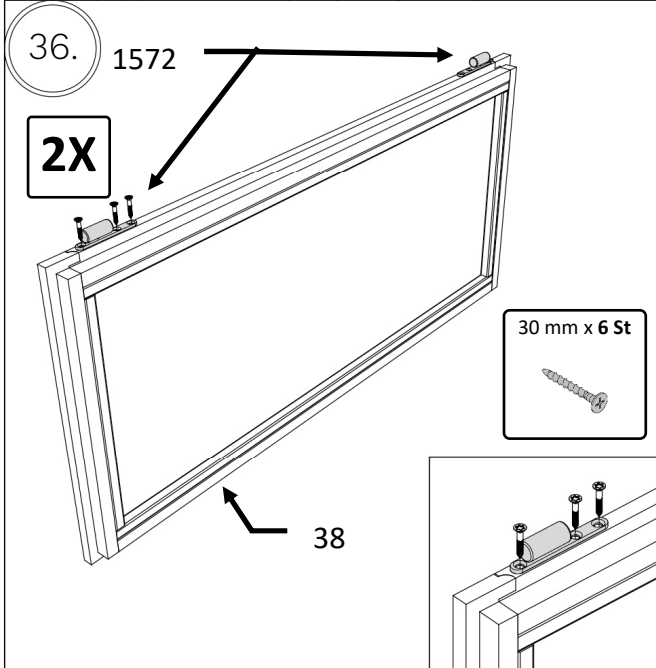
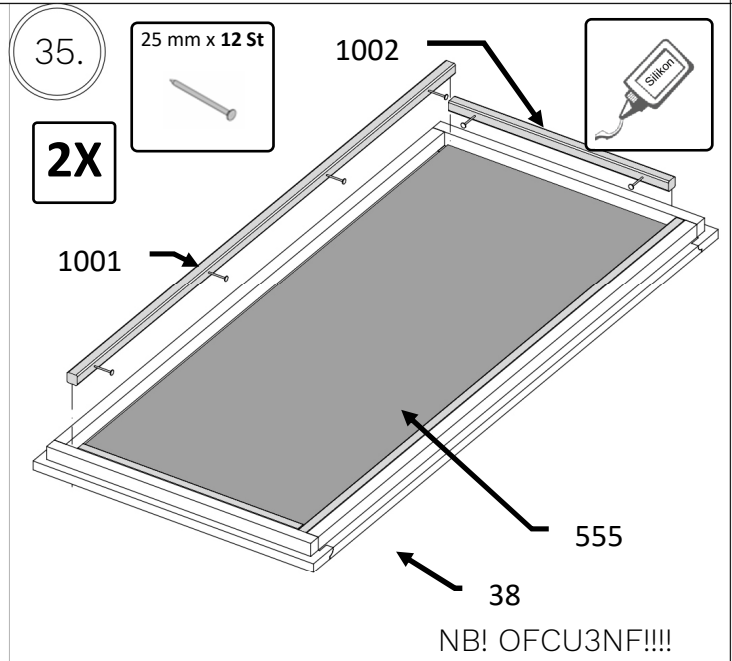
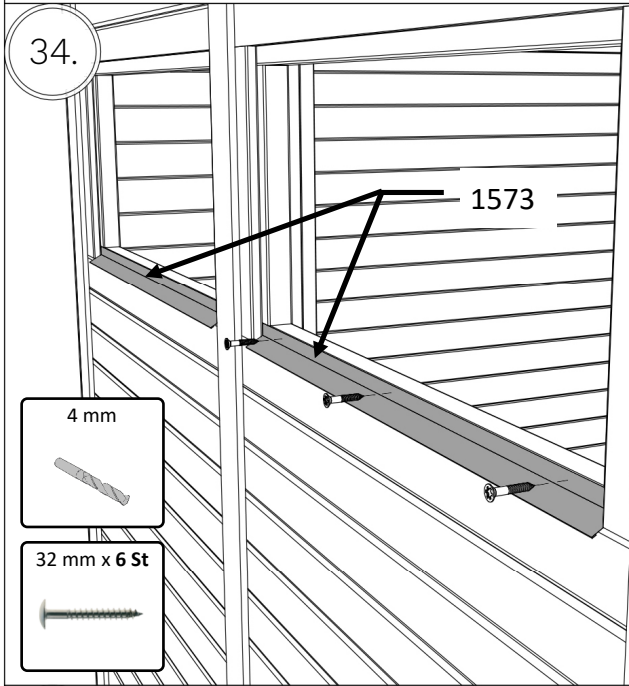

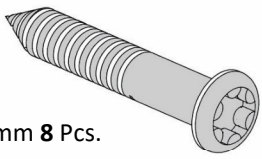

# OFCU3(NF/GR/AN)

Version 1.

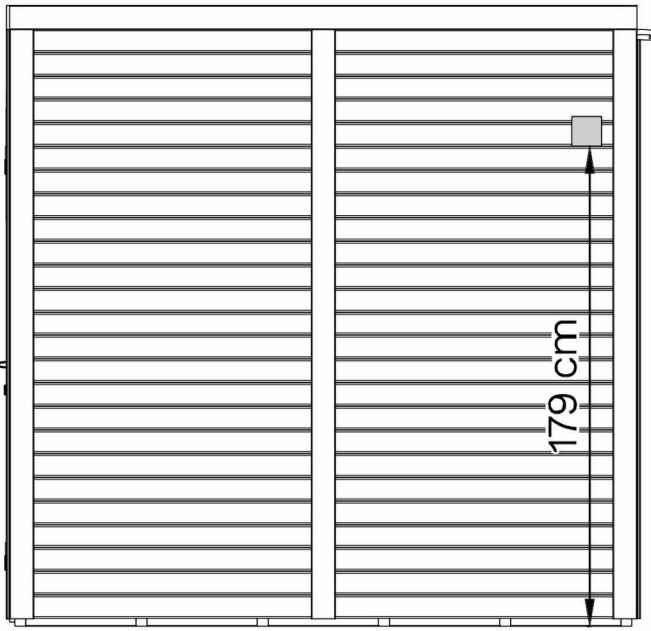
1.   $\varnothing 3 \times 19 \text{ mm}$  8 Pcs.  
1557 2 Pcs.

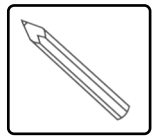

2.  179 cm

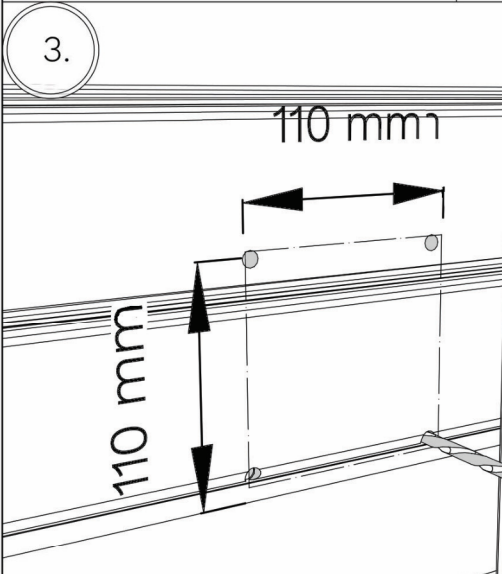

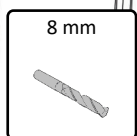

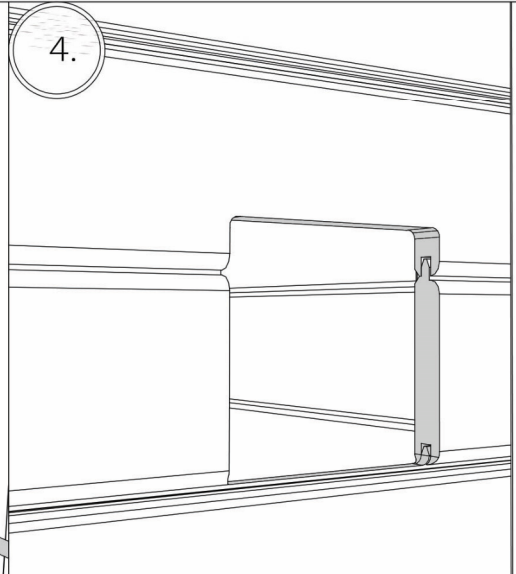
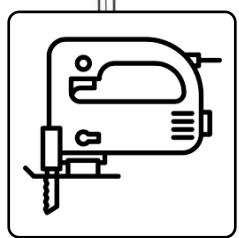
3.  110 mm 110 mm

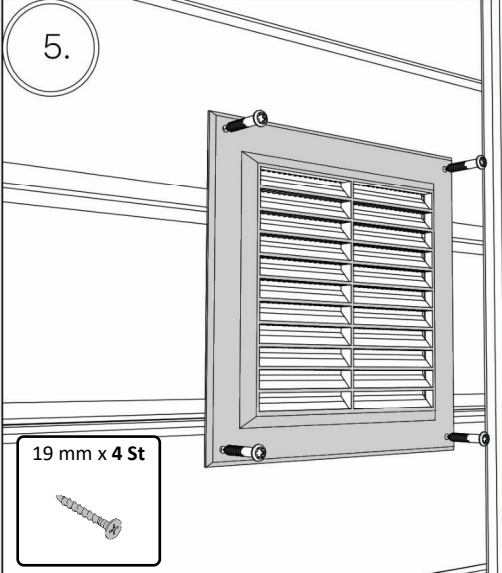
8 mm 

4.  

5.  19 mm x 4 St 

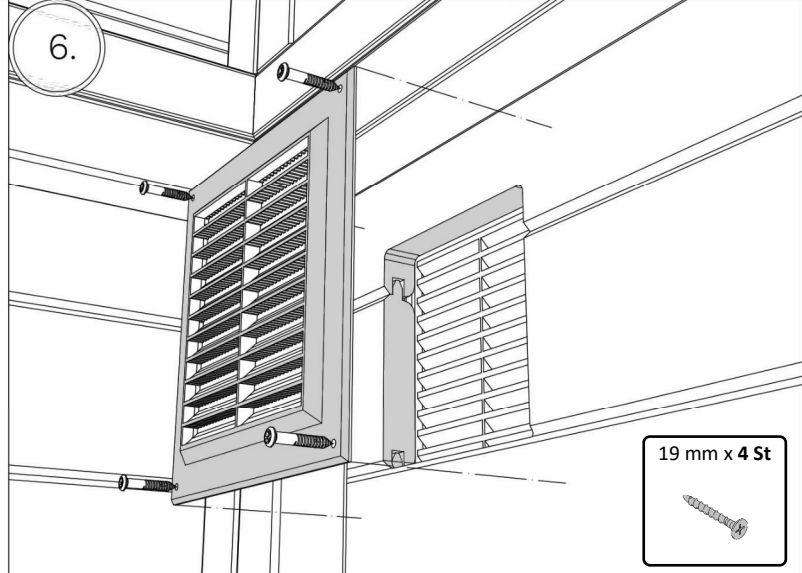
Silikon 

6.  19 mm x 4 St 

# OFCU3(NF/GR/AN)

Version 2.

