

Assembly, installation and maintenance manual

Montage-, Aufbau- und Wartungsanleitung • Assemblage, manuel de montage et d'entretien • Montaje, instalación y mantenimiento • Manuale di montaggio, installazione e manutenzione • Monterings- og vedlikeholdsmanual • Monterings-, installations- och underhållsmanual • Kokoamis-, asennus- ja huolto-ohje • Vejledning for montering og vedligehold • Handleiding voor montage, installatie en onderhoud • Manual de montagem, instalação e manutenção • Návod k montáži, instalaci a údržbě • Instrukcja montażu, instalacji i konserwacji • Surinkimo, montavimo ir priežiūros vadovas • Montāžas, uzstādīšanas un apkopes rokasgrāmata • Руководство по сборке и обслуживанию • Montaaži-, paigaldus- ja säilitamise juhend



Pavilion PA120-5842-1

| | |
|---|---|
| <p>Factory inspection by • Werkskontrolle durch • Contrôle à partir de l'usine par • Inspector de fábrica • Collaudato da • Fabrikkontroll utført av • Fabriksbesiktigat av • Tehtaan tarkastaja • Fabriks Kontrol udført af • Fabriekscontrole door • Inspeção de fábrica, por: • Zkontrolováno ve výrobním závodě • Kontrola fabryczna do • Apžiūrą gamykloje atliko • Rūpnīcas pārbaudi veicis • Заводской контроль • Tehase kontroll teostatud:</p> <p>.....</p> | <p>Date • Datum • Date • Fecha • Data • Dato • Datum • Päiväys • Dato • Datum • Data • Datum • Data • Datums • Data • Дата • Kuupäev:</p> <hr/> <p>Pack number • Pack Nr. • Packet n° • Bulto N° • Pacco N. • Serienr • Produktionsnummer • Paċettinro • Pakke nr. • Pak nr. • Número de embalagem • Číslo balení • Numer opakowania • Pakuotės numeris • Iepakojuma numurs • Упаковочный номер • Pakinumber:</p> |
|---|---|



www.palmako.ee/information-hub

English: Before installing and using the product, please read the instructions and warranty terms at www.palmako.ee/information-hub to guarantee proper installation and long-lasting performance.

Deutsch: Wichtig! Bitte vor Aufbau und Nutzung des Produkts unbedingt die detaillierte Montageanleitung sowie die Garantiebedingungen unter www.palmako.ee/information-hub lesen, um eine fachgerechte Montage und eine lange Funktionssicherheit zu gewährleisten.

Français: Avant d'installer et d'utiliser le produit, veuillez lire les instructions et les conditions de garantie sur www.palmako.ee/information-hub afin de garantir une installation correcte et la longévité du produit.

Español: Antes de instalar y utilizar el producto, lea las instrucciones y las condiciones de garantía en www.palmako.ee/information-hub para asegurar una instalación correcta y una larga vida útil del producto.

Italiano: Prima di installare e utilizzare il prodotto, leggere le istruzioni e le condizioni di garanzia su www.palmako.ee/information-hub per garantire una corretta installazione e prestazioni durature.

Norsk: Før montering og bruk av produktet, vennligst les monteringsanvisningene og garantivilkårene på www.palmako.ee/information-hub for å sikre korrekt montering og fremtidig holdbarhet.

Svenska: Innan du installerar och använder produkten, vänligen läs instruktionerna och garantivillkoren på www.palmako.ee/information-hub för att säkerställa korrekt installation och produktens långvariga hållbarhet

Suomi: Ennen tuotteen asentamista ja käyttämistä, lue ohjeet ja takuehdot osoitteessa www.palmako.ee/information-hub varmistaaksesi oikean asennuksen ja pitkäkestoisen toiminnan.

Русский: Перед установкой и использованием изделия ознакомьтесь с инструкцией и условиями гарантии на сайте www.palmako.ee/information-hub, чтобы гарантировать правильную установку и долговечность изделия.

Eesti: Enne toote paigaldamist ja kasutuselevõttu lugege palun juhiseid ja garantiitingimusi aadressil www.palmako.ee/information-hub, et tagada nõuetekohane paigaldus ja toote pikk eluiga.

Dansk (Oversat af AI): Læs venligst instruktionerne og garantibetingelserne på www.palmako.ee/information-hub, før du installerer og bruger produktet, for at garantere korrekt installation og langvarig ydeevne.

Dutch (Vertaald door AI): Lees vóór de installatie en het gebruik van het product de instructies en garantievoorwaarden op www.palmako.ee/information-hub om een correcte installatie en langdurige werking te garanderen

Português (Traduzido por IA): Antes de instalar e utilizar o produto, leia as instruções e os termos de garantia em www.palmako.ee/information-hub para garantir uma instalação adequada e um desempenho duradouro.

Čeština (Přeloženo umělou inteligencí): Před instalací a použitím produktu si prosím přečtěte pokyny a záruční podmínky na www.palmako.ee/information-hub, abyste zaručili správnou instalaci a dlouhodobý výkon.

Polski (Przetłumaczone przez AI): Przed zainstalowaniem i użyciem produktu należy przeczytać instrukcję oraz warunki gwarancji dostępne na stronie www.palmako.ee/information-hub, co pozwoli zagwarantować prawidłową instalację i długotrwałą wydajność.

Latviešu (Mākslīgā intelekta tulkojums): Pirms produkta uzstādīšanas un lietošanas, lūdzu, izlasiet instrukcijas un garantijas noteikumus vietnē www.palmako.ee/information-hub, lai garantētu pareizu uzstādīšanu un ilgstošu darbību.

Lietuviškai (Išvertė DI): Prieš montuodami ir naudodami gaminį, perskaitykite instrukcijas ir garantijos sąlygas adresu www.palmako.ee/information-hub, kad užtikrintumėte tinkamą montavimą ir ilgalaikį veikimą.

582









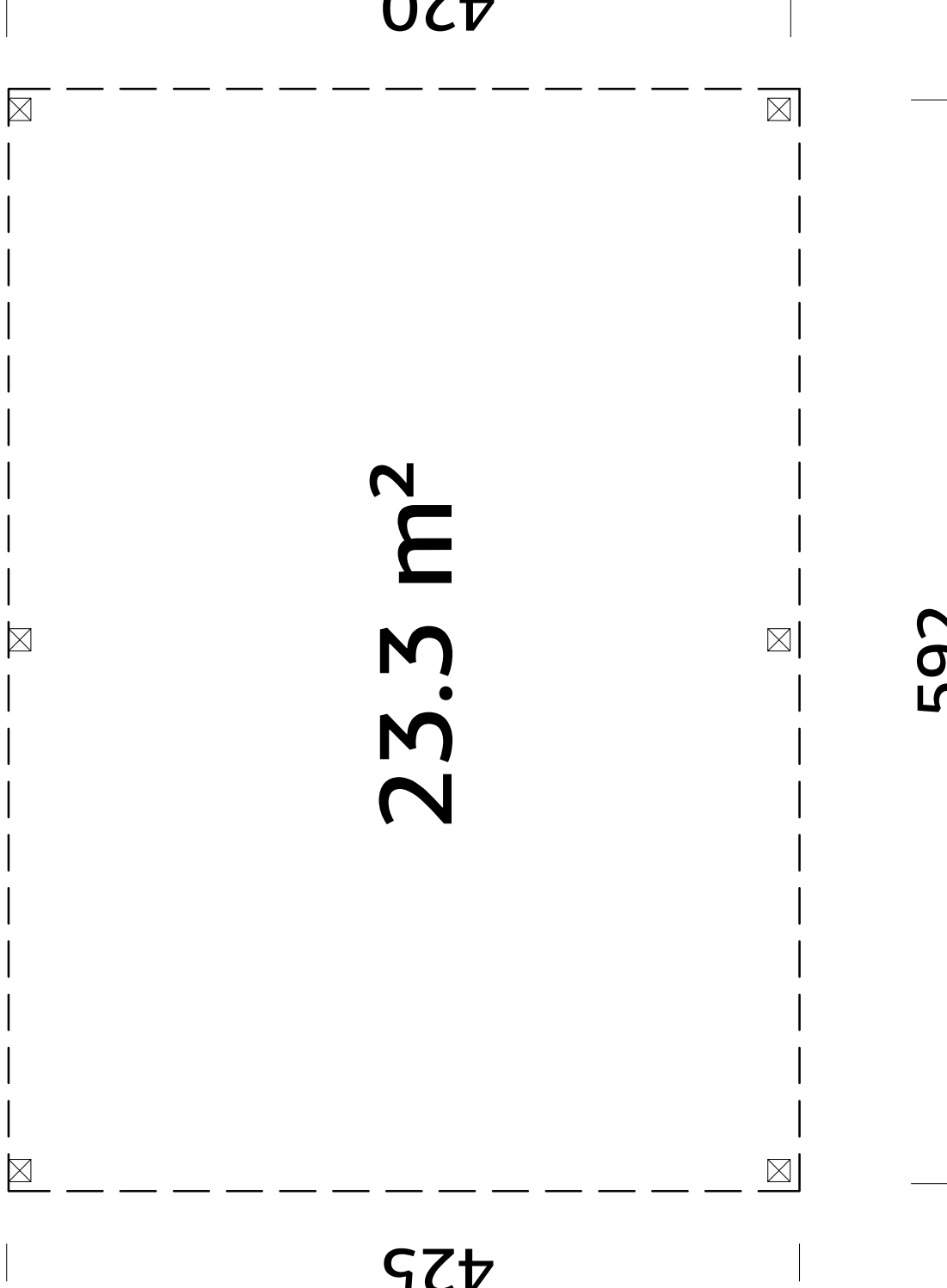



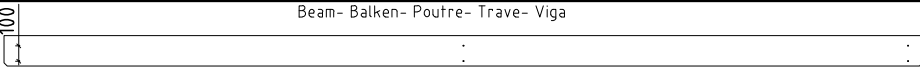
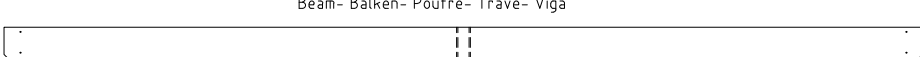
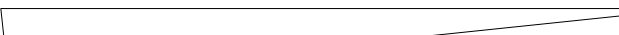
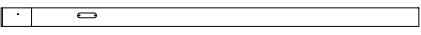

420

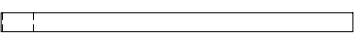
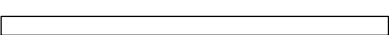
23.3 m²

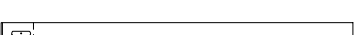
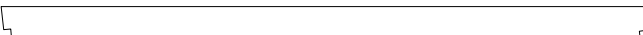
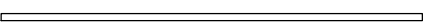
425

592



| Pos | SPECIFICATION-STÜCKLISTE-NOMENCLATURE-ELEMENTI-ESPECIFICACIÓN PA120-5842-1 | Pcs | Profile (mm) | Length (mm) |
|-------|---|-----|-----------------|----------------|
| TTP1 | Tender post- Tenderleiste- T-poste- Rinforzo- Refuerzo T  | 1 | 120x120 | 2215 |
| AR1 | Foundation- Fundament- Fondation- Fondazione- Vigas de cimentación  | 2 | 95x45 | 4190 |
| AR2 | Foundation- Fundament- Fondation- Fondazione- Vigas de cimentación  | 4 | 95x45 | 1810 |
| AR3 | Foundation- Fundament- Fondation- Fondazione- Vigas de cimentación  | 2 | 95x45 | 2000 |
| BM1 | Beam- Balken- Poutre- Trave- Viga  | 2 | 160x60 | 4040 |
| BM2 | Beam- Balken- Poutre- Trave- Viga  | 1 | 60x200 | 5910 |
| BM3 | Beam- Balken- Poutre- Trave- Viga  | 1 | 60x200 | 5910 |
| BM4 | Beam- Balken- Poutre- Trave- Viga  | 2 | 42x200 | 3987 |
| Pst1 | Post- Pfosten- Poteau- Montante- Poste  | 1 | 120x120 | 2687 |
| Pst2 | Post- Pfosten- Poteau- Montante- Poste  | 1 | 120x120 | 2263 |
| Pst3 | Post- Pfosten- Poteau- Montante- Poste  | 1 | 120x120 | 2263 |
| Pst4 | Post- Pfosten- Poteau- Montante- Poste  | 1 | 60x120 | 2492 |
| Pst5 | Post- Pfosten- Poteau- Montante- Poste  | 1 | 120x120 | 2687 |
| Pst6 | Post- Pfosten- Poteau- Montante- Poste  | 1 | 120x120 | 2263 |
| RoR1 | Rafter- Sparre- Chevron- Trave- Cabrio  | 12 | 42x200 | 4119 |
| Sla1 | Slat- Leiste- Baguette- Listello- Listón  | 2 | 45x45 | 2710 |
| Sla2 | Slat- Leiste- Baguette- Listello- Listón  | 2 | 45x45 | 2790 |
| Sla3 | Slat- Leiste- Baguette- Listello- Listón  | 2 | 45x45 | 4000 |
| RB2-1 | Roof board- Dachbrett- Madrier du toit- Tavola tetto- Tabla de tejado  | 51 | 89x19 | 3206 |
| RB2-2 | Roof board- Dachbrett- Madrier du toit- Tavola tetto- Tabla de tejado  | 51 | 89x19 | 2704 |
| WP5-1 | Wall panelling- Wandverkleidung- Revetement du mur- Rivestimento di muro- Revestimiento de pared  | 64 | 135x18 | 650 |
| | | | | |
| | | | | |
| | | | | |
| | | | | |

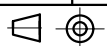

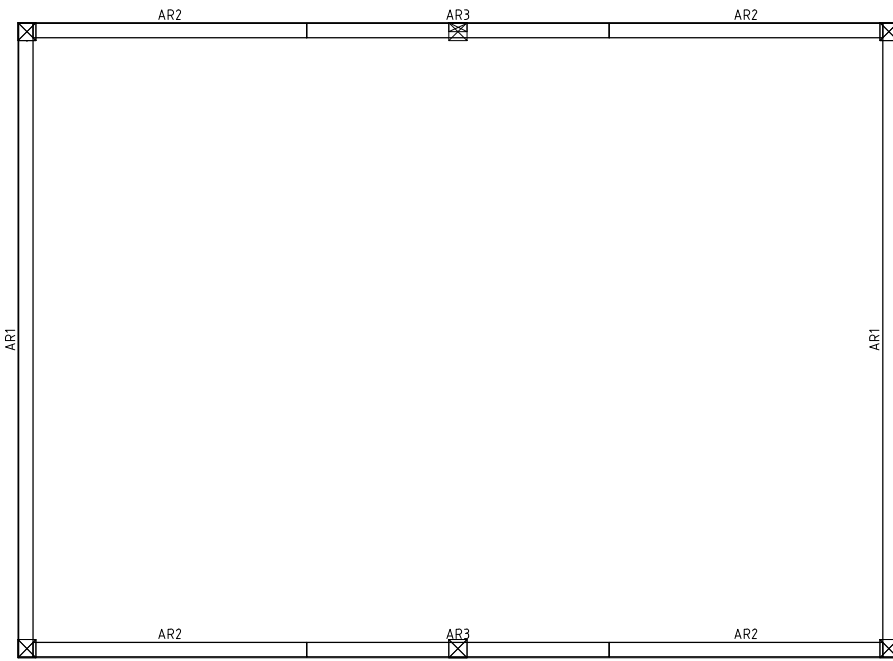

NB!

1.

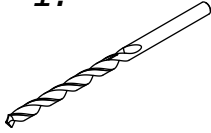

2.

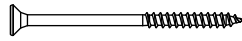

| | |
|------------------------------|-----------------------|
| $\varnothing 1,5 \text{ mm}$ | $\varnothing 3,0...4$ |
| $\varnothing 2,0 \text{ mm}$ | $\varnothing 4,5$ |
| $\varnothing 6,0 \text{ mm}$ | $\varnothing 8,0$ |

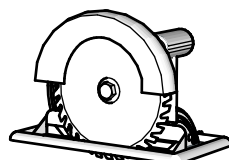
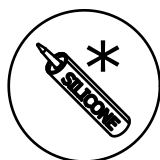
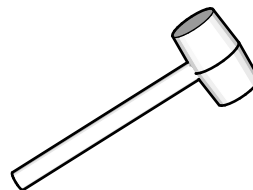
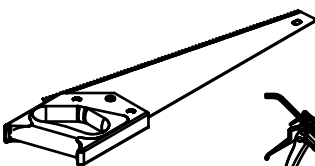
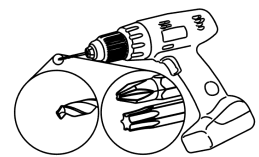
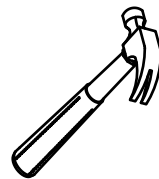
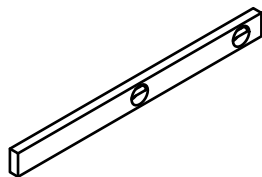
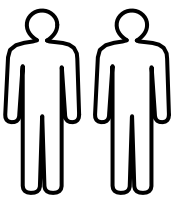
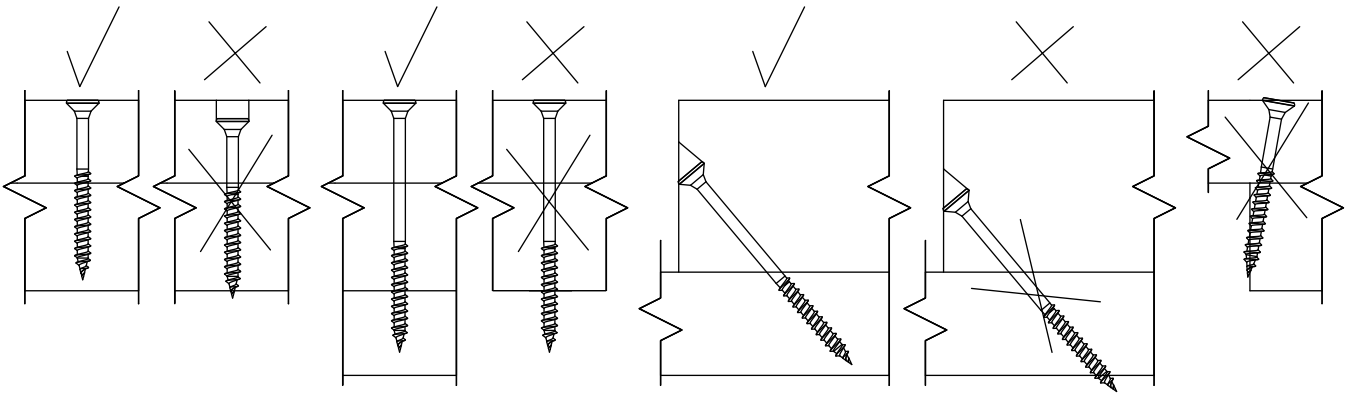

| | | |
|-----|---|-----------------------|
| ENG | - | Not included |
| GER | - | Nicht enthalten |
| FR | - | Non inclus |
| ES | - | No incluso |
| IT | - | Non incluso |
| NO | - | Ikke inkludert |
| SWE | - | Ingår inte |
| FIN | - | Ei sisälly hintaan |
| DEN | - | Ikke inkluderet |
| NED | - | Niet inbegrepen |
| POR | - | Não incluído |
| CZ | - | Není zahrnuto |
| POL | - | Nie wliczone |
| LIT | - | Neįtraukta |
| LAT | - | Nav iekļauts |
| RUS | - | Не включено |
| EST | - | Ei sisaldu komplektis |

| | | |
|-----|---|------------------------|
| ENG | - | Separate manual |
| GER | - | Separates Handbuch |
| FR | - | Manuel séparé |
| ES | - | Manual separado |
| IT | - | Manuale separato |
| NO | - | Separat manual |
| SWE | - | Separat manual |
| FIN | - | Erillinen käyttöohje |
| DEN | - | Separat manual |
| NED | - | Aparte handleiding |
| POR | - | Manual separado |
| CZ | - | Samostatný manuál |
| POL | - | Osobna instrukcja |
| LIT | - | Atskiras vadovas |
| LAT | - | Atsevišķa rokasgrāmata |
| RUS | - | Отдельное руководство |
| EST | - | Eraldi juhend |

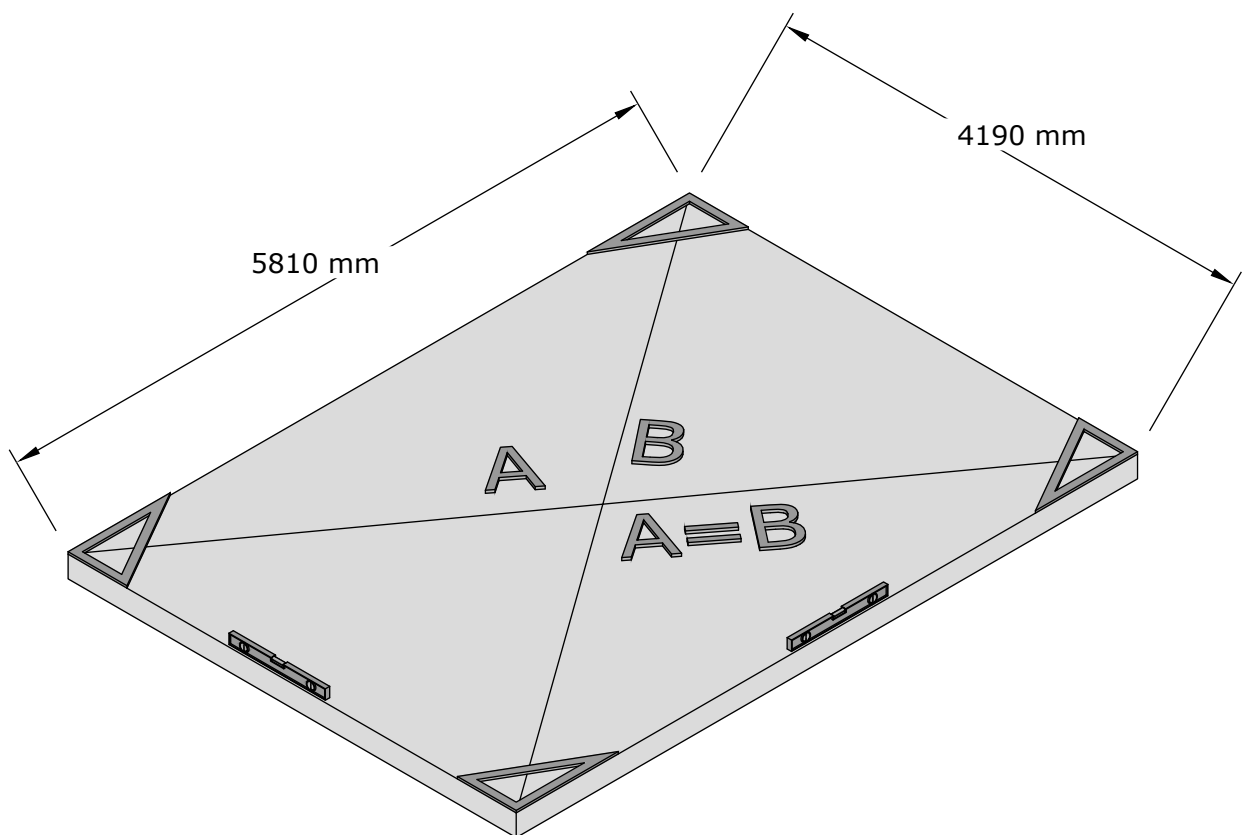
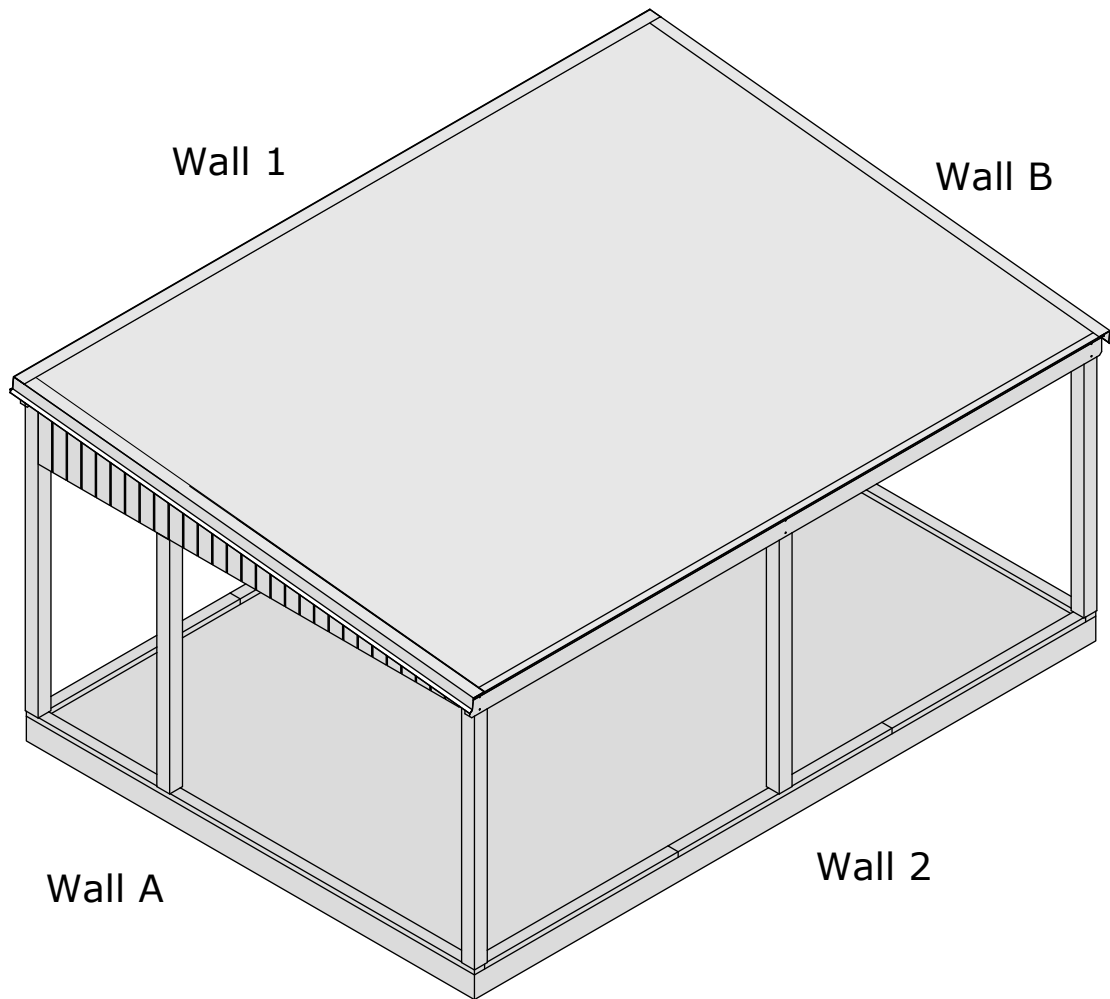

- PST1* x1
- PST2* x1
- PST5* x1
- PST6* x1
- TTP1* x1
- AR1* x2
- BM1* x2
- BM4* x2

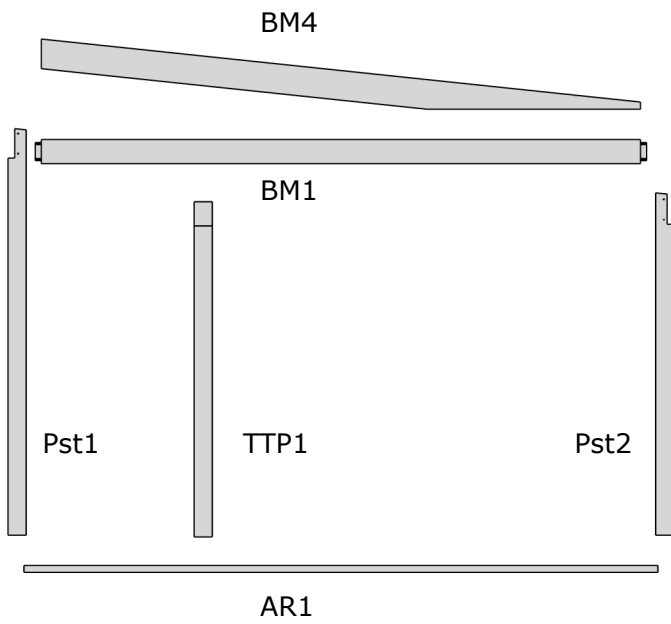

Wall A

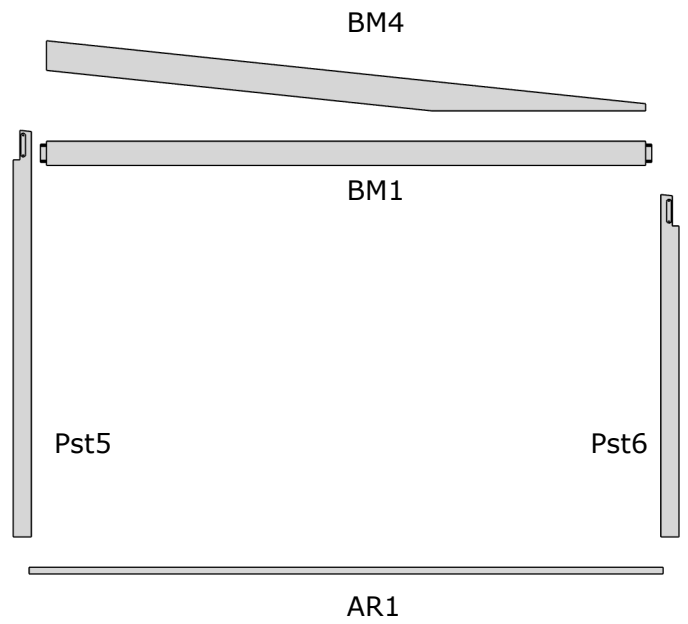

Wall B

- PST1 x1
- PST2 x1
- PST5 x1
- PST6 x1
- TTP1 x1
- AR1 x2
- BM1 x2
- BM4 x2

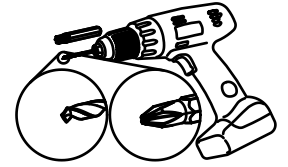

- Ø8x220 x2
- Ø8x260 x4

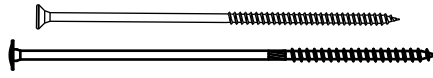

A

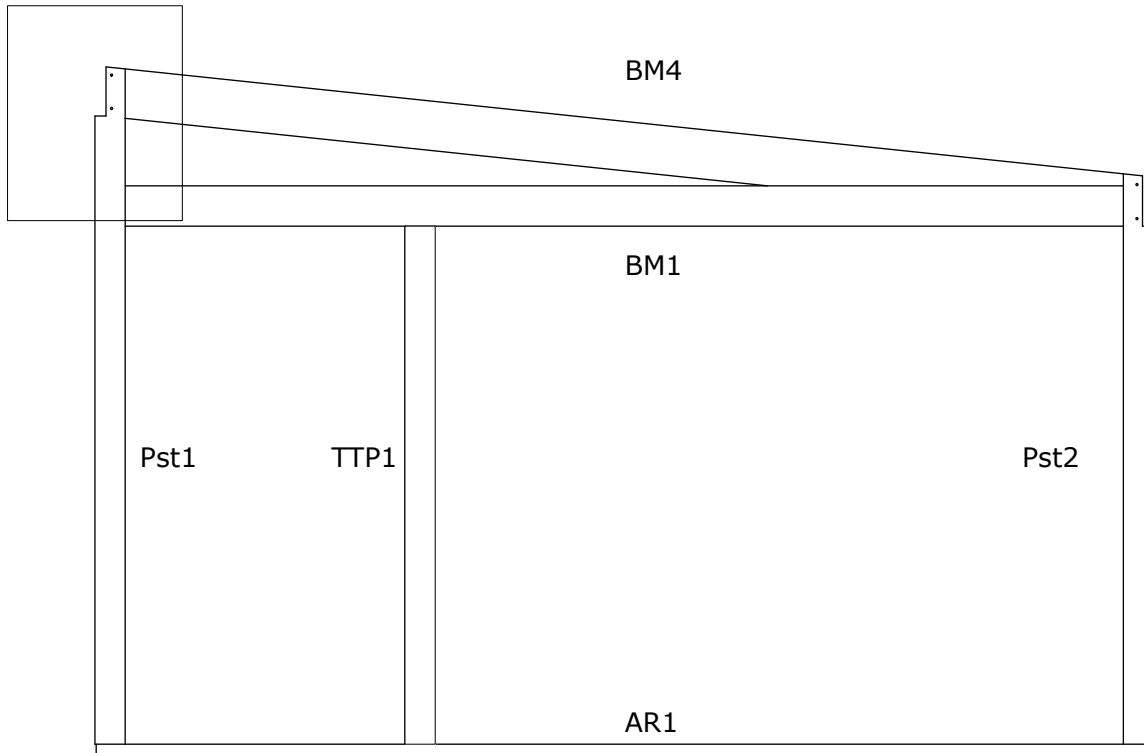

Wall A

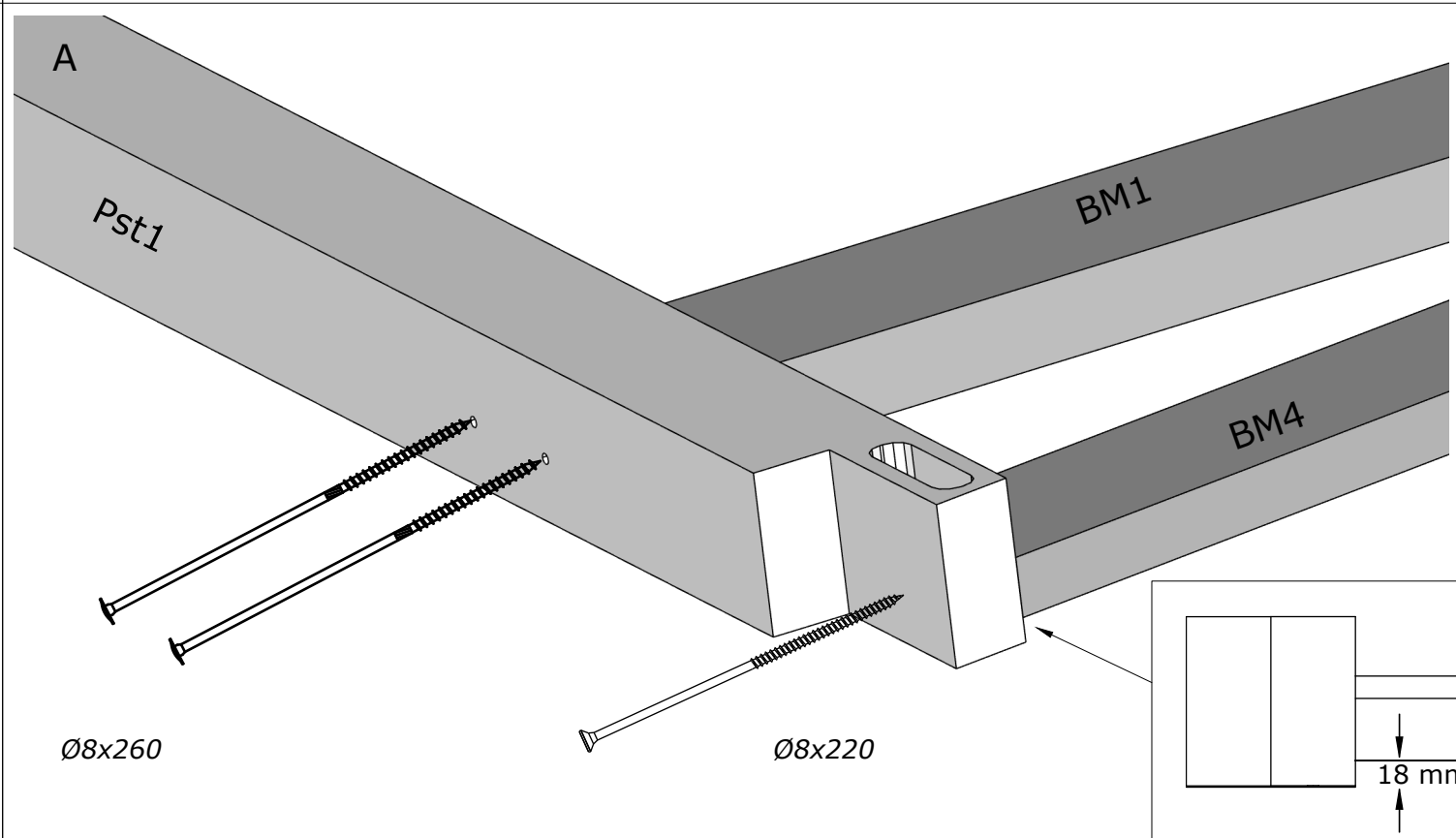

Ø8x260

Ø8x220

18 mm

- PST1 x1
- PST2 x1
- PST3 x1
- PST4 x1
- AR1 x2
- BM1 x2
- BM4 x2
- TTP1 x1

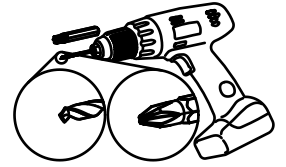

- Ø8x220 x2
- Ø6x160 x4

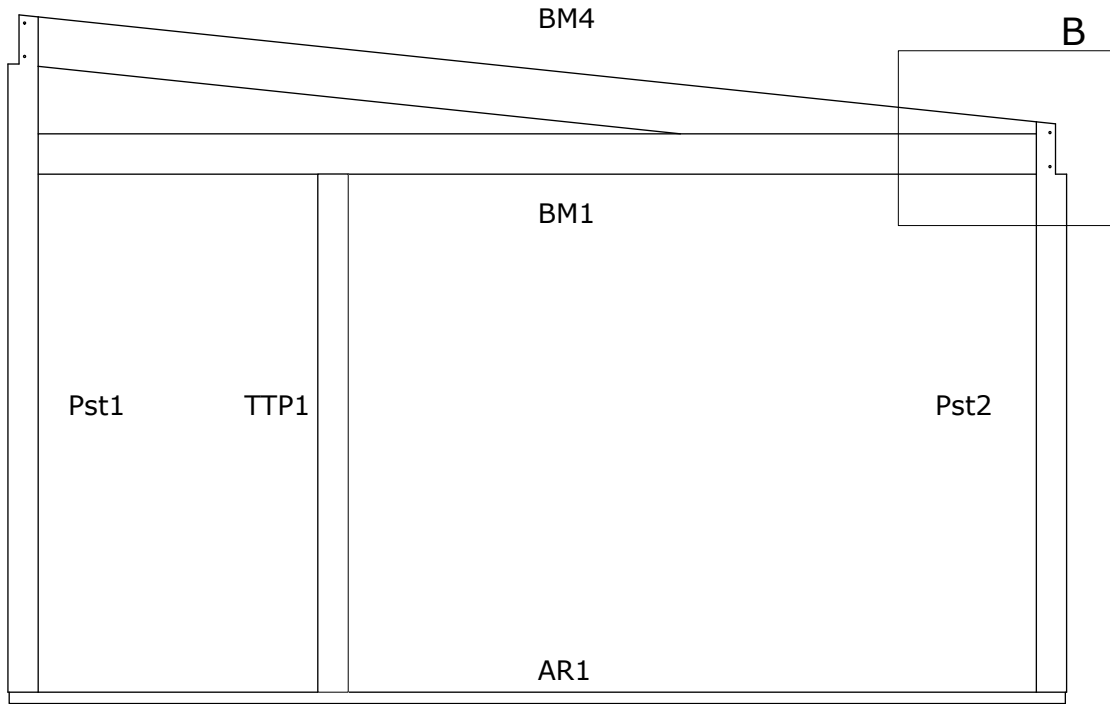
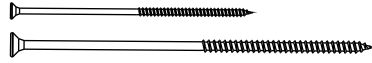

Wall A

B

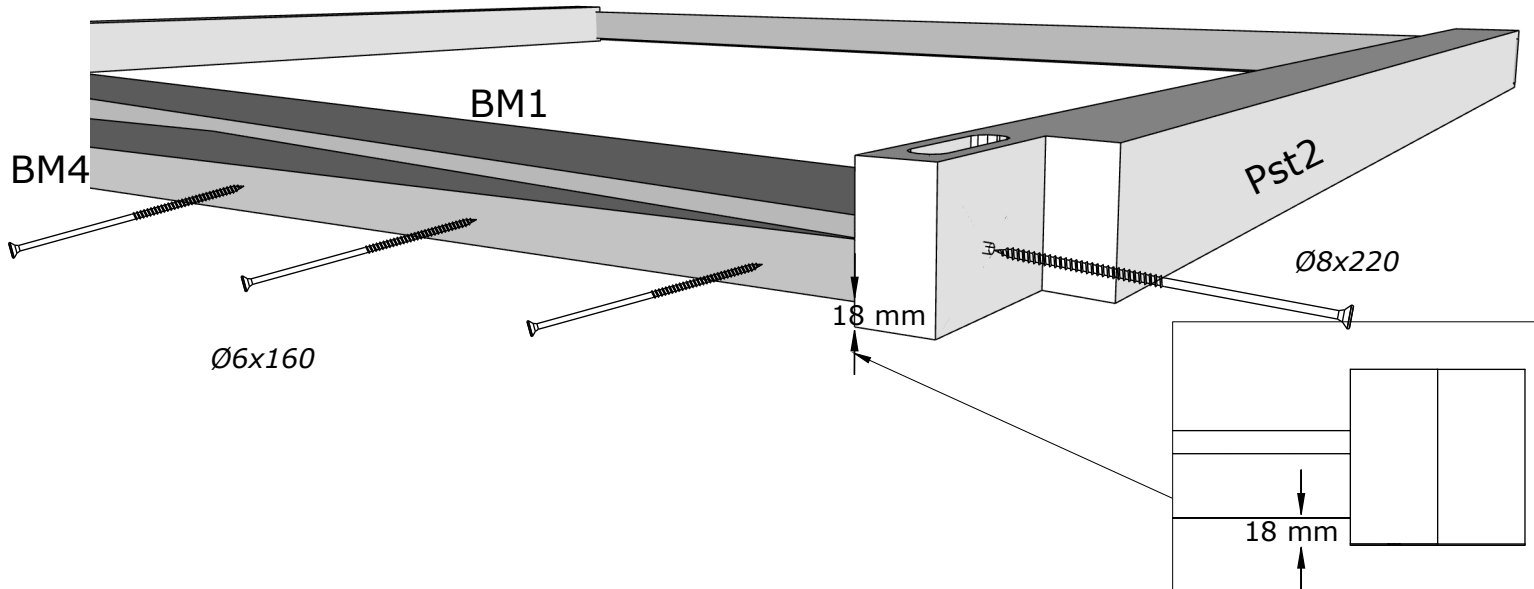

AR1 x2

Ø8x220 x4

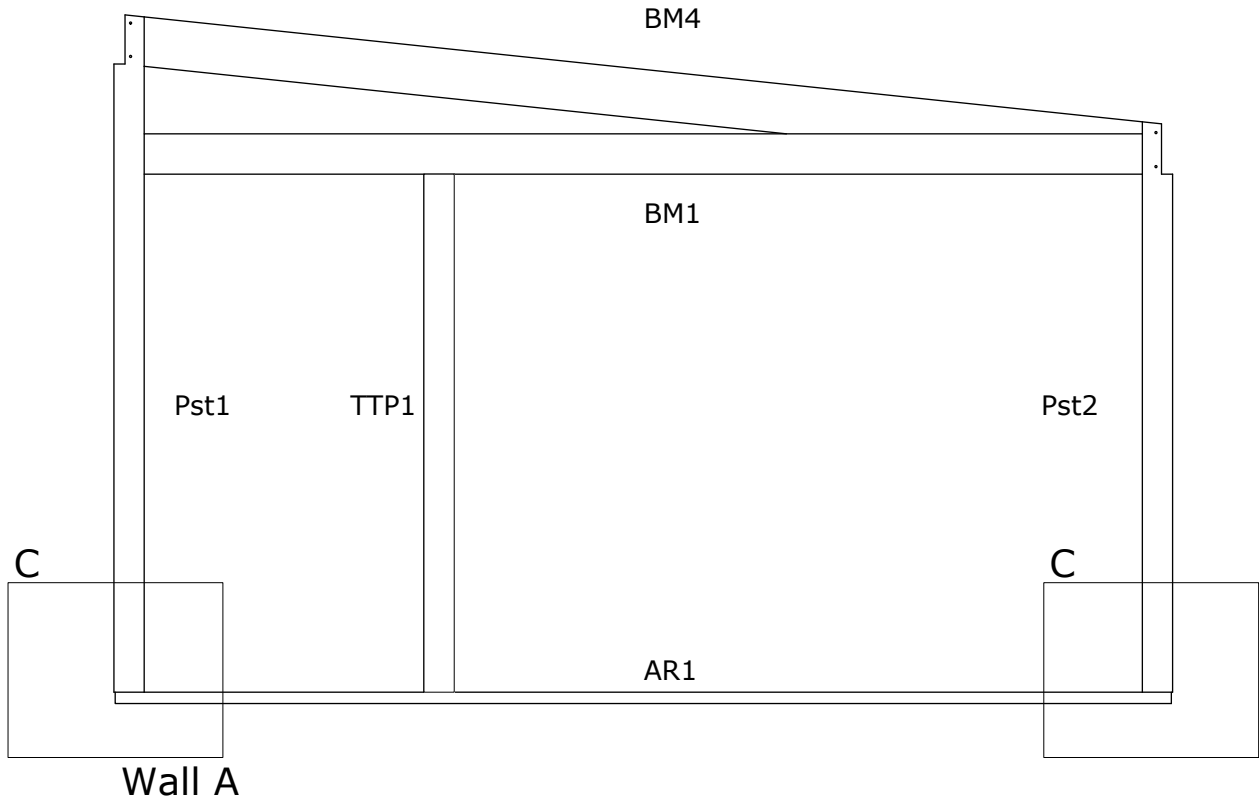
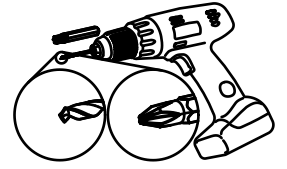
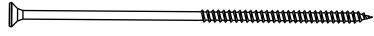

C

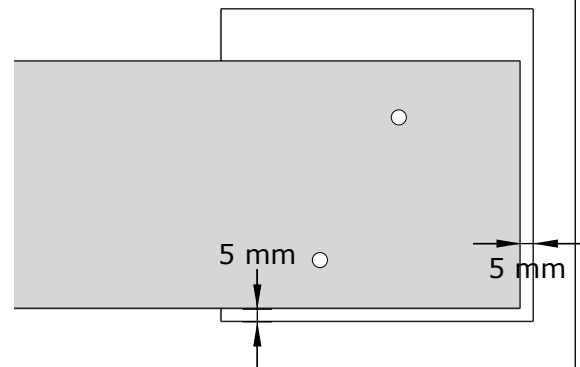
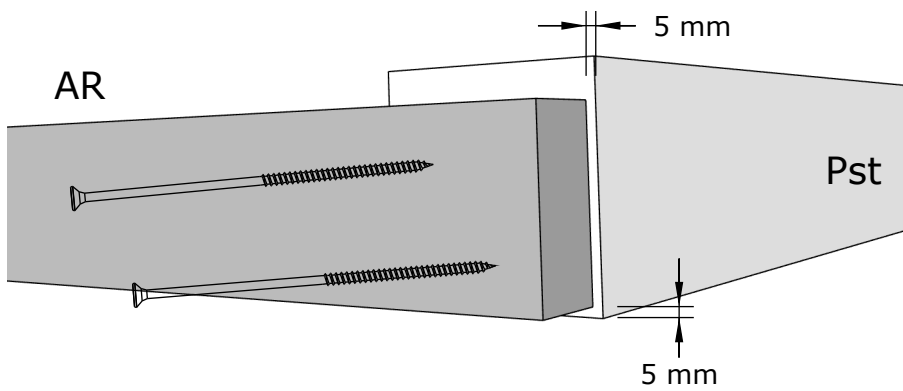

TTP1 x1

Ø8x100 x4
Ø8x220 x2

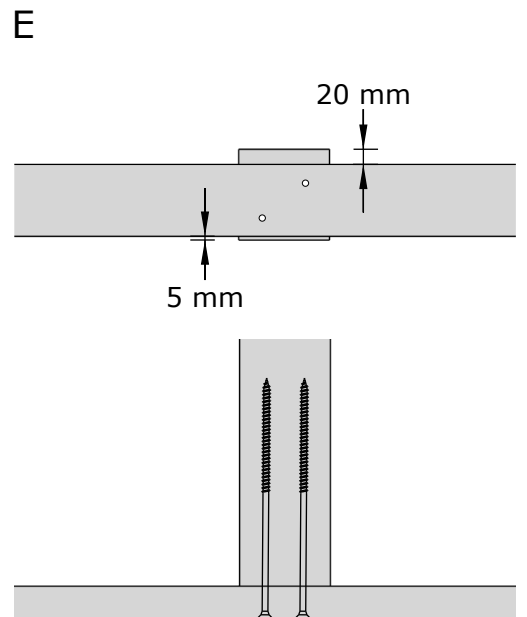
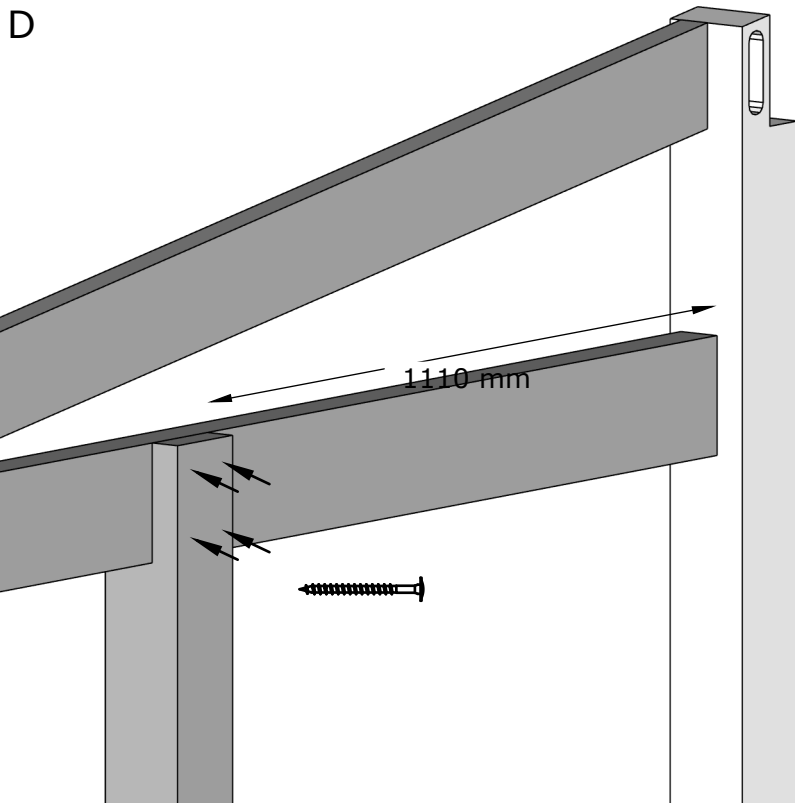
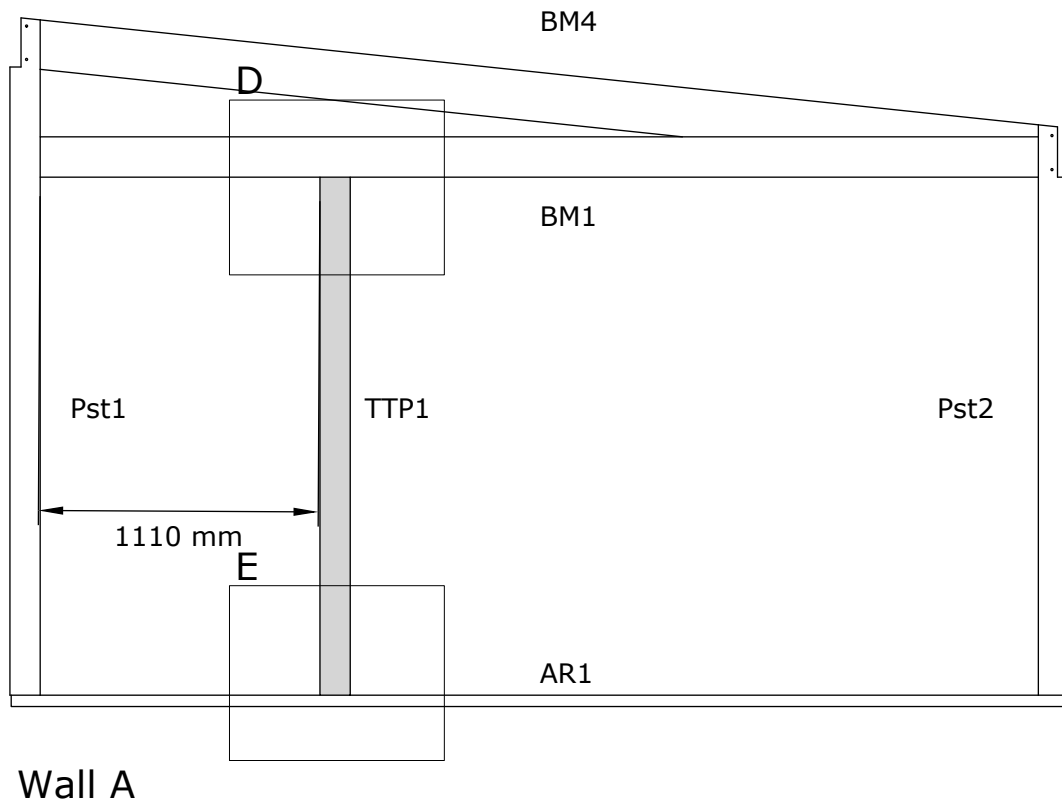
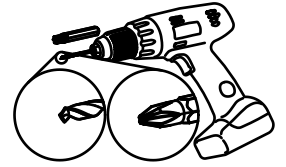
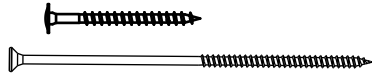

WP5-1 x64
Ø2,2x50 x130

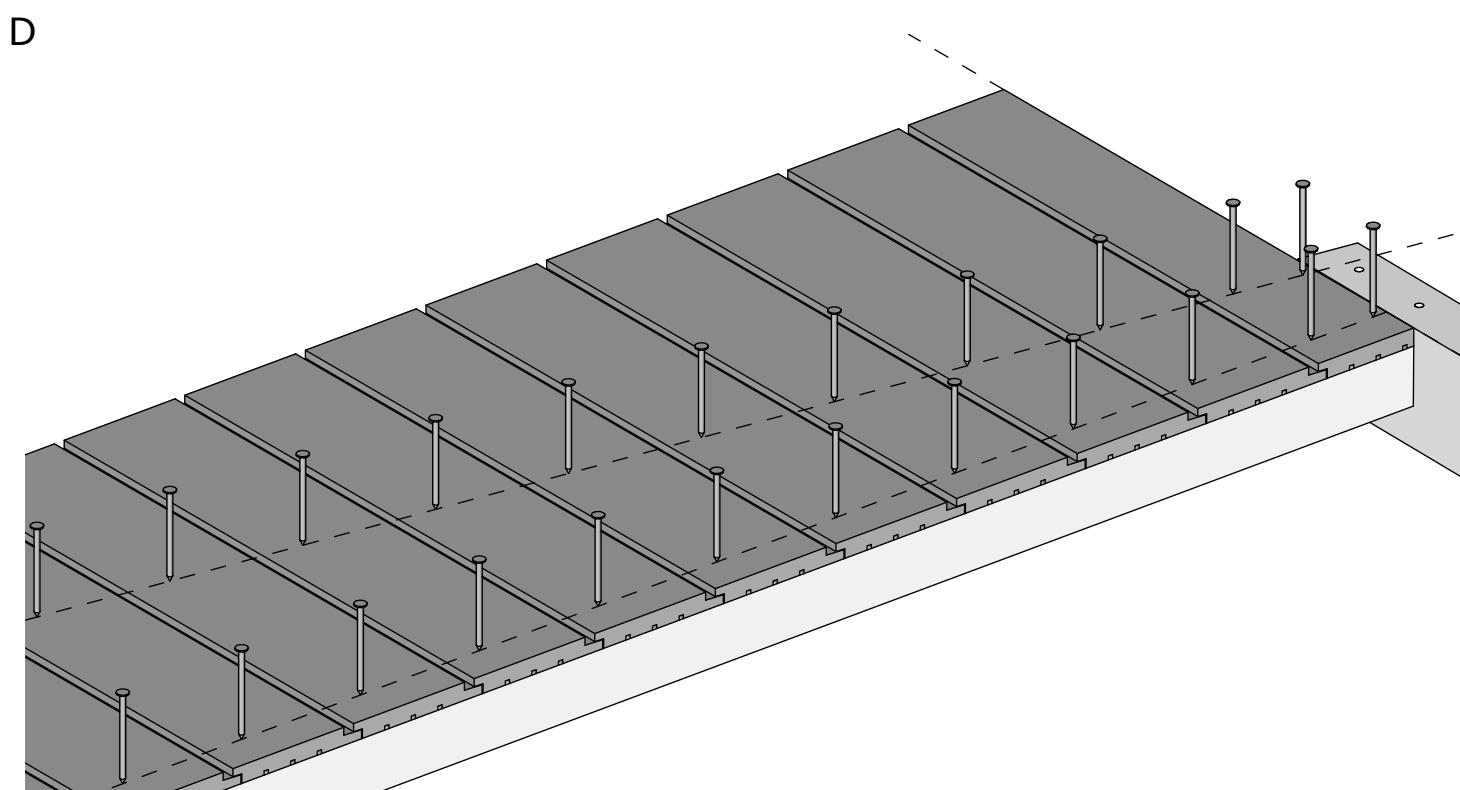
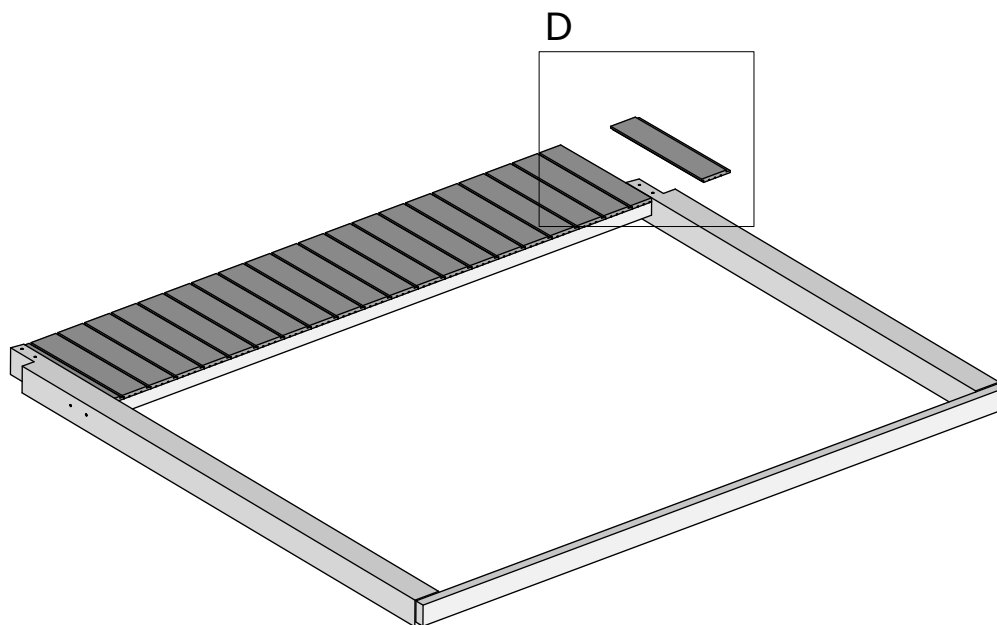
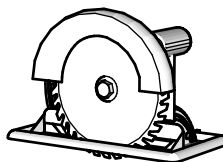
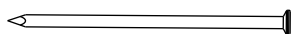

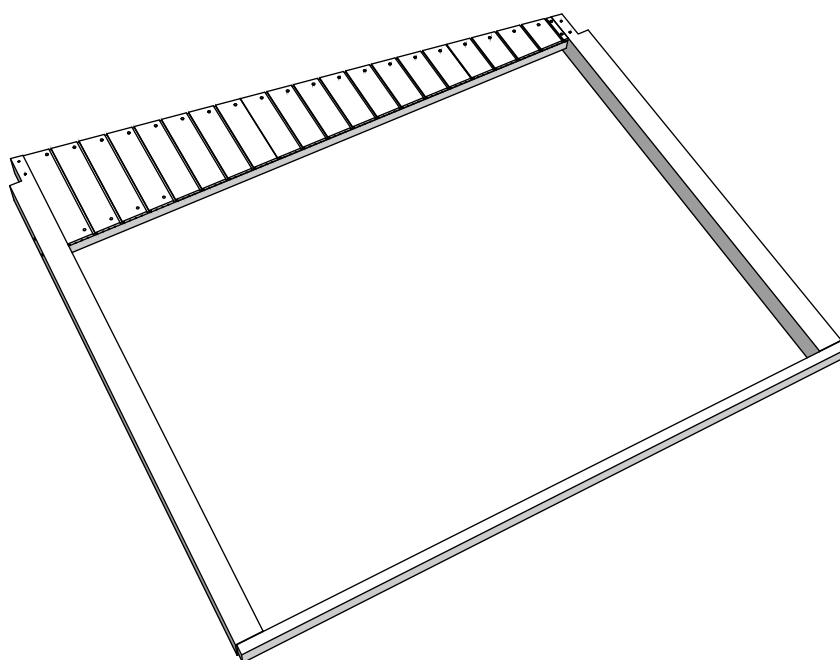
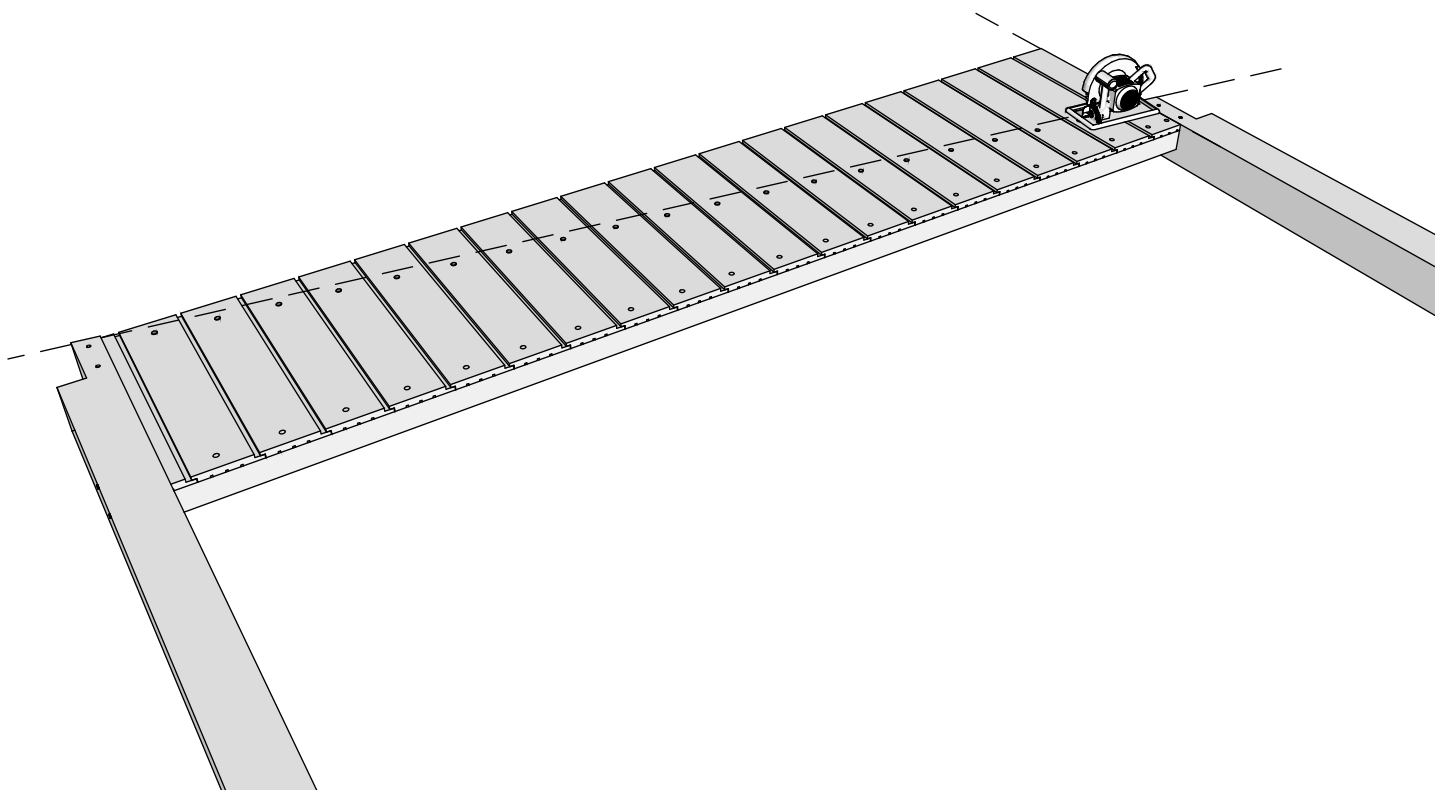
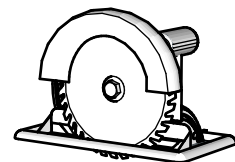

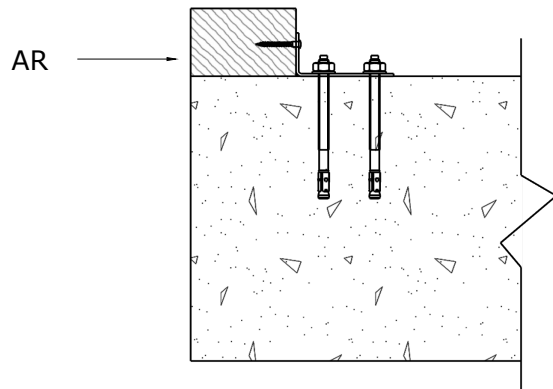
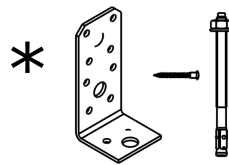
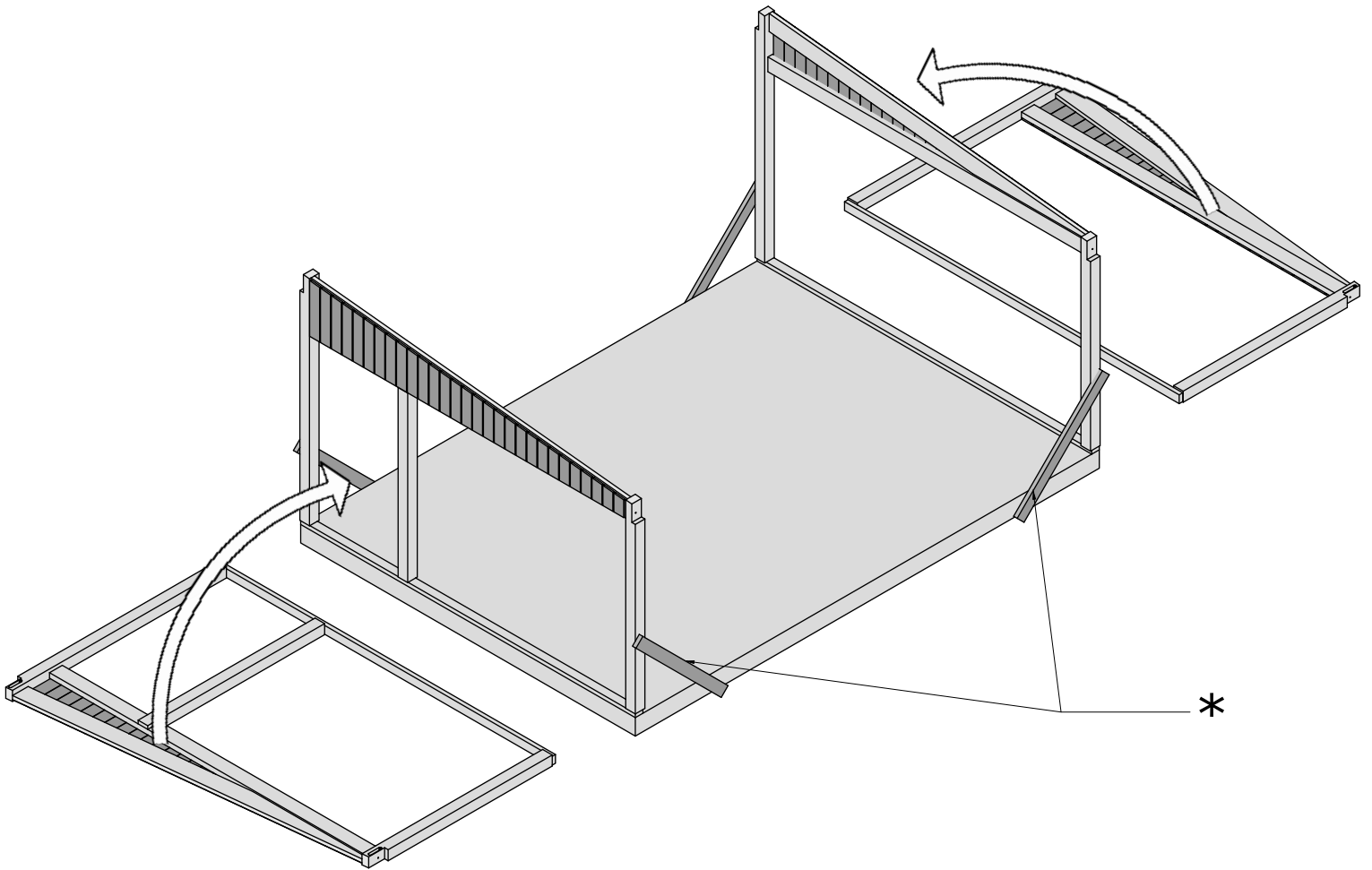
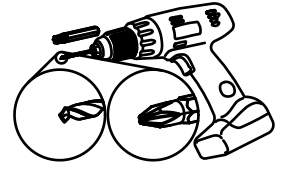
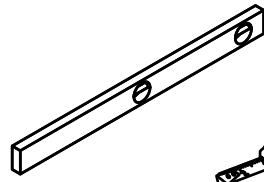

BM2 x1
BM3 x1

Ø8x260 x8

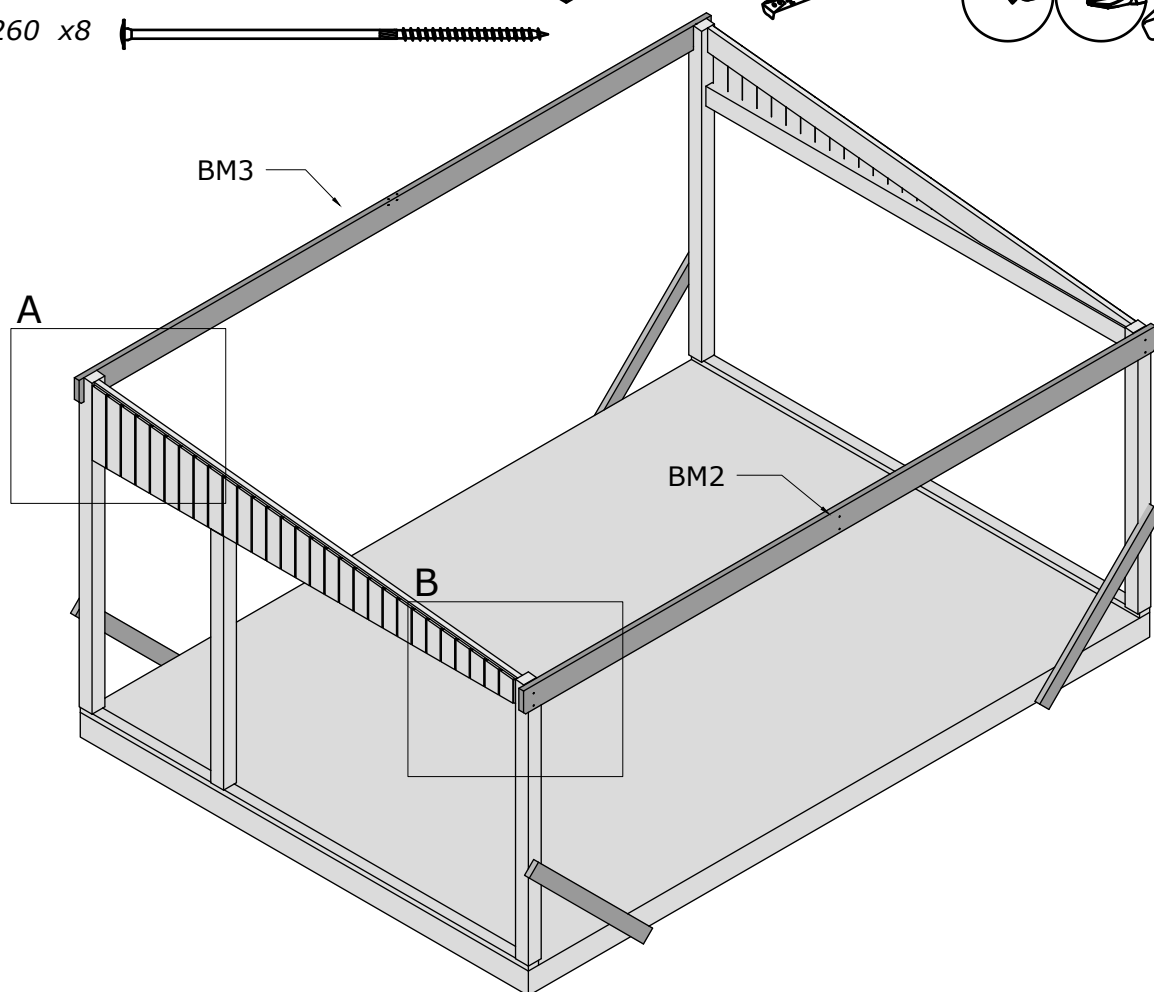
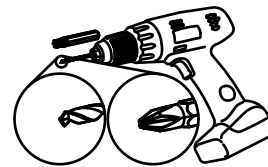
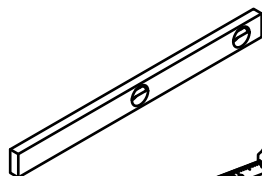
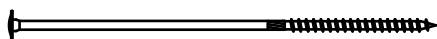

A

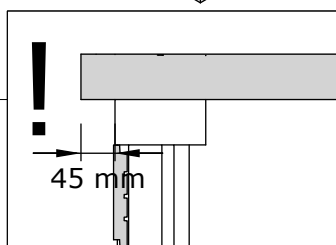

45 mm

B

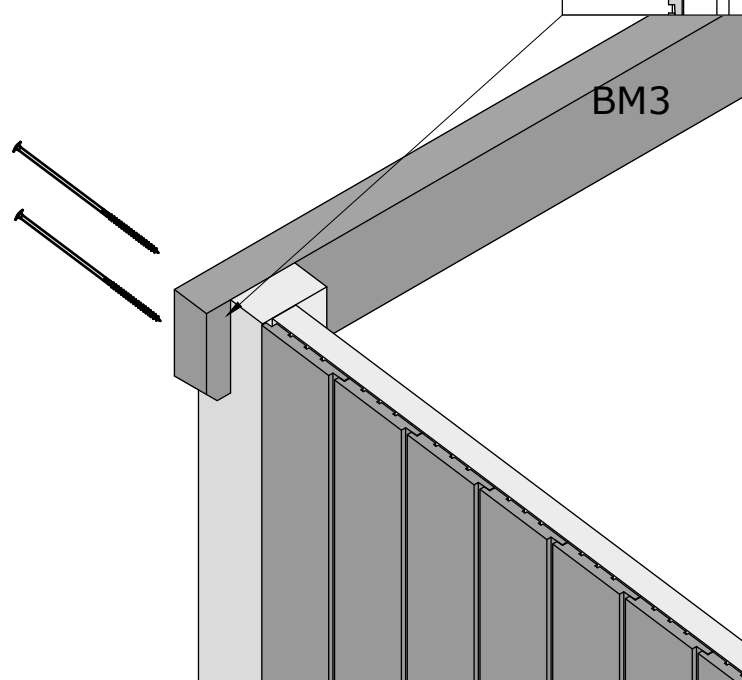

BM3

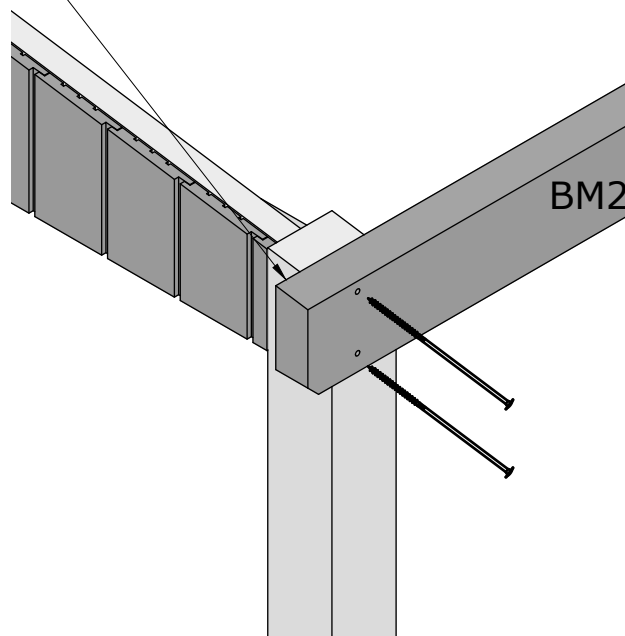

BM2

PST3 x1
PST4 x1
AR3 x2

Ø8x220 x4

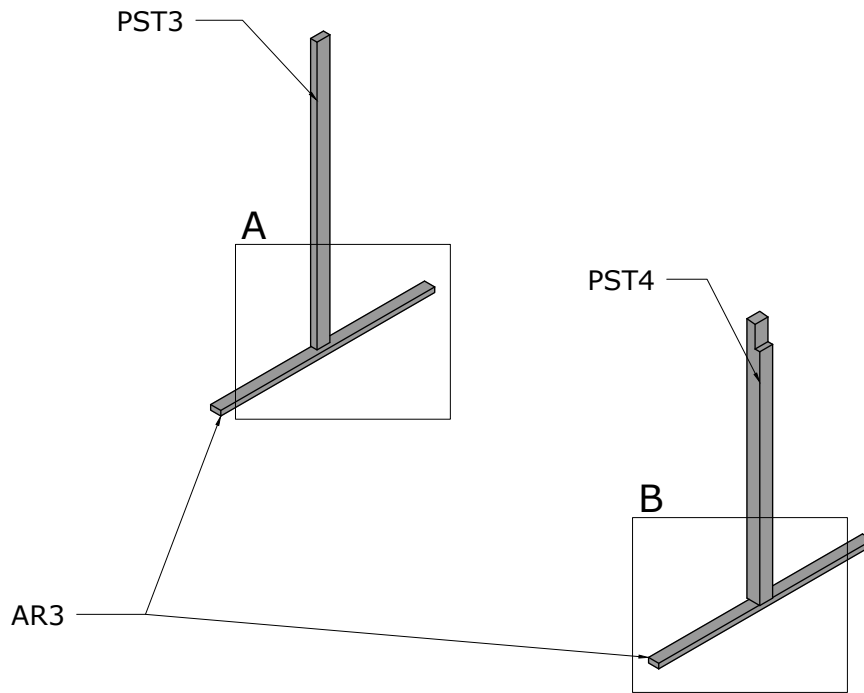
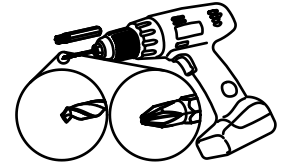
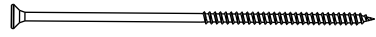

A

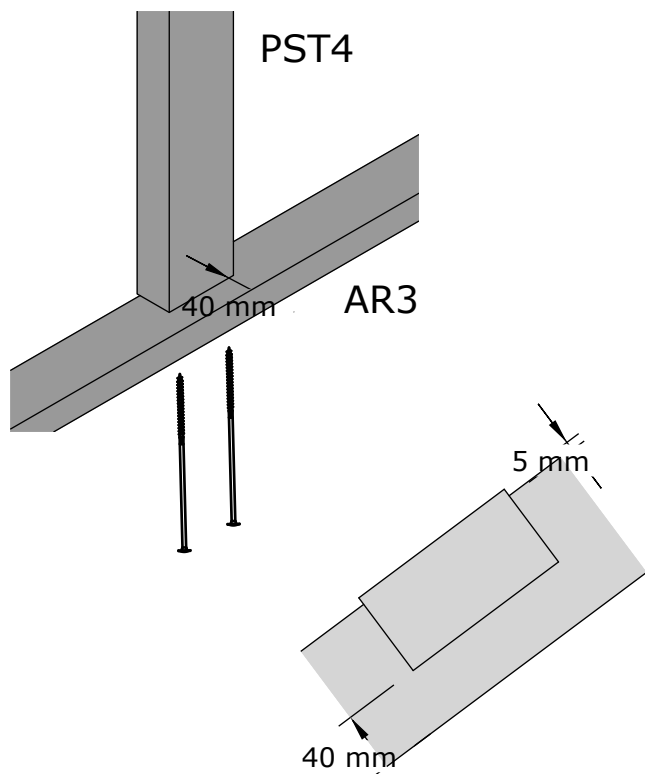

B

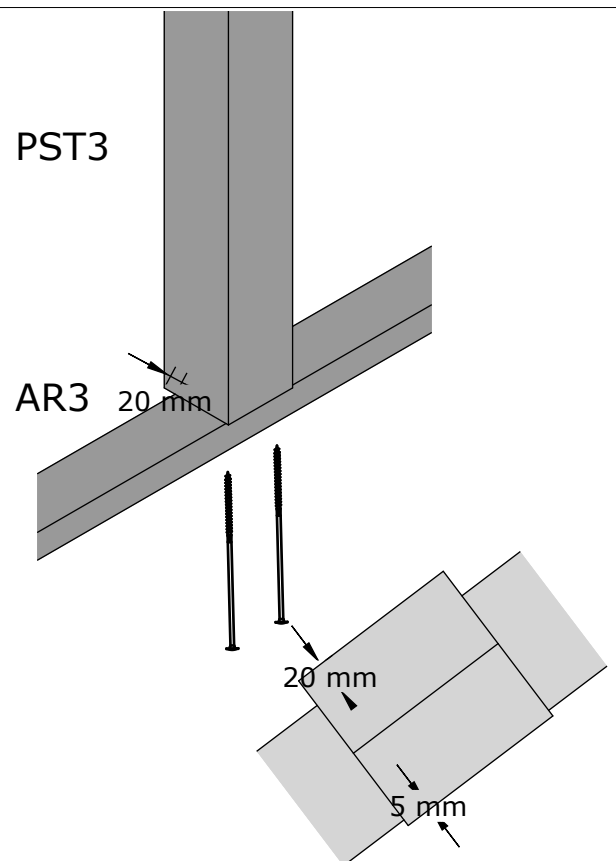

Ø8x100 x2
Ø8x260 x2

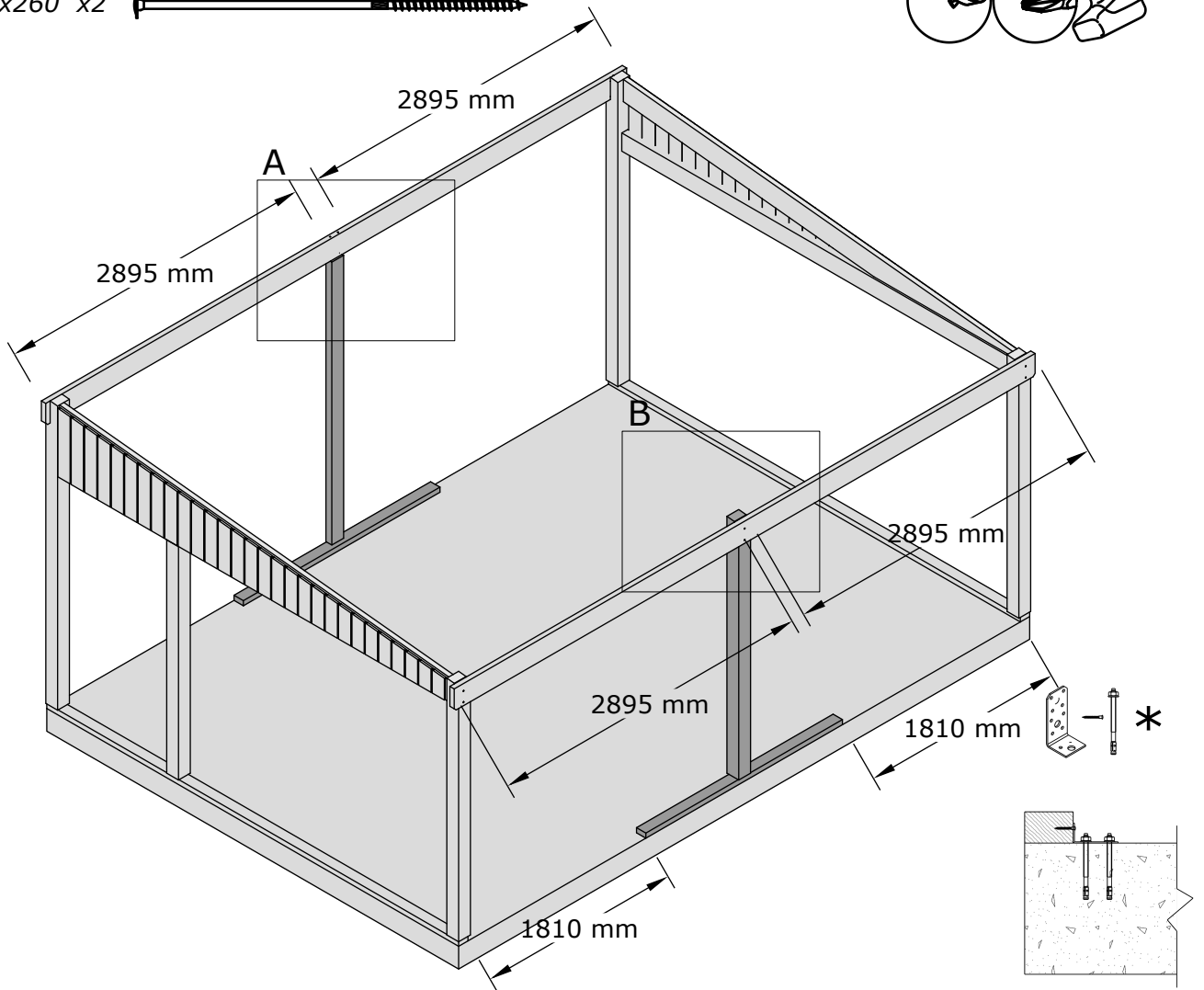
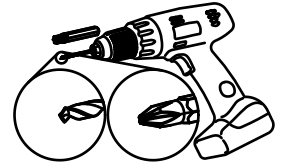
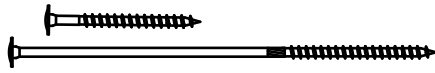

A

Ø8x260

BM3

PST4

B

BM2

Ø8x100

PST3

AR2 x4

Ø8x220 x8

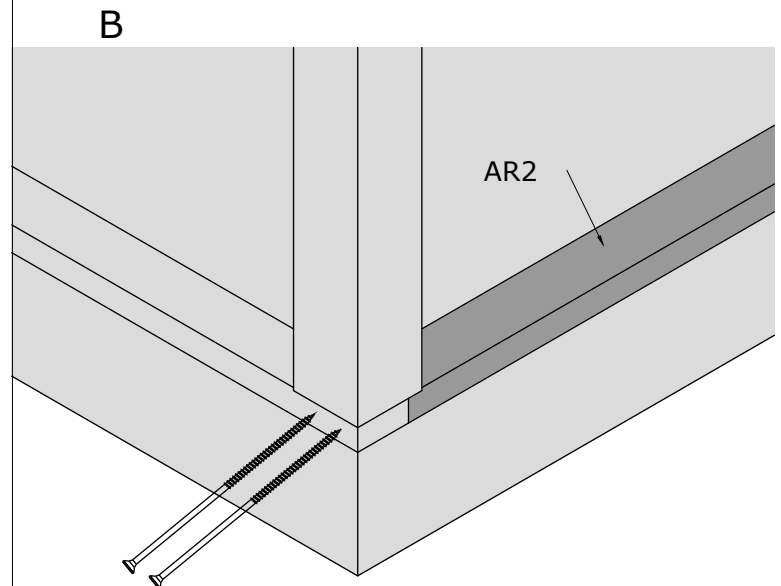
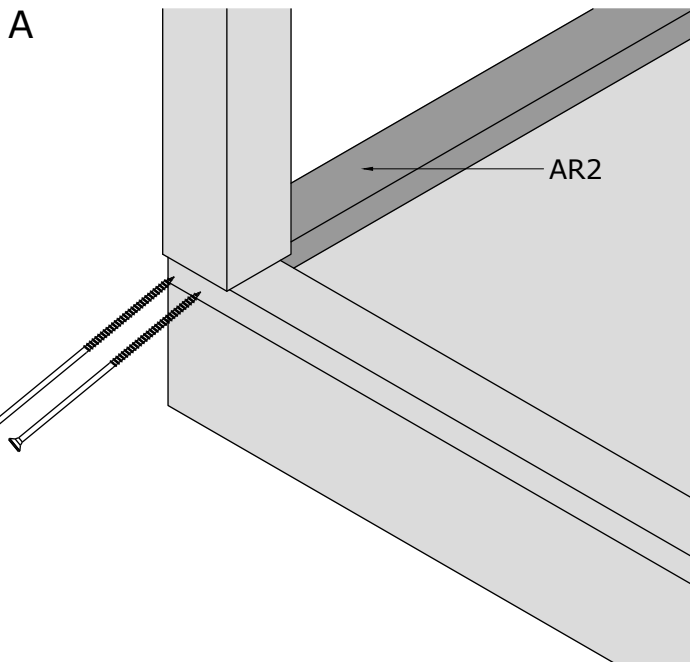
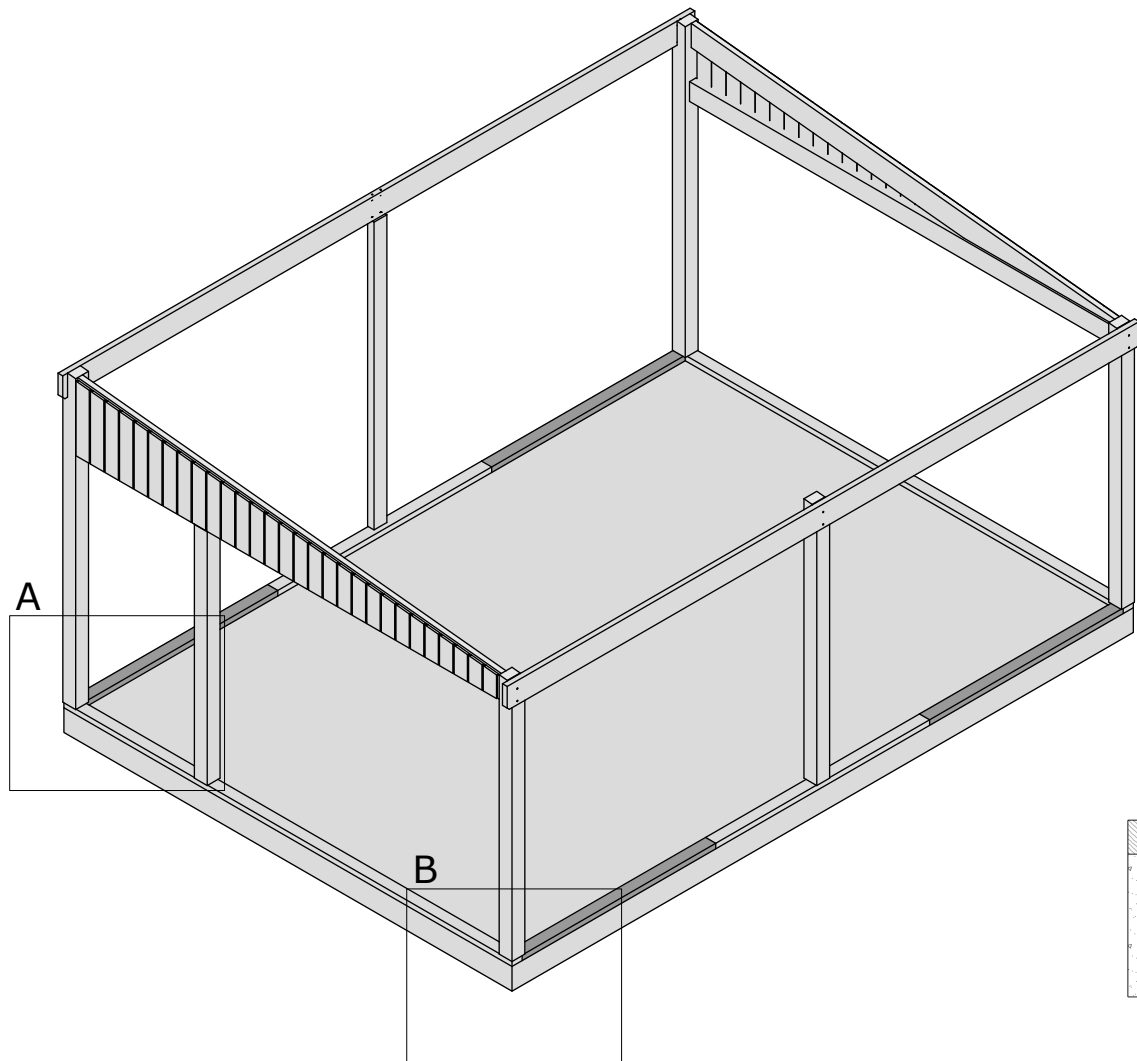
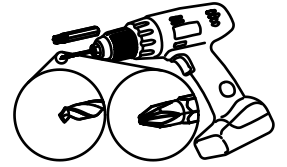

Sla1 x2

Sla2 x2

Ø5x80 x28

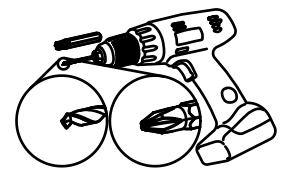
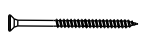

A

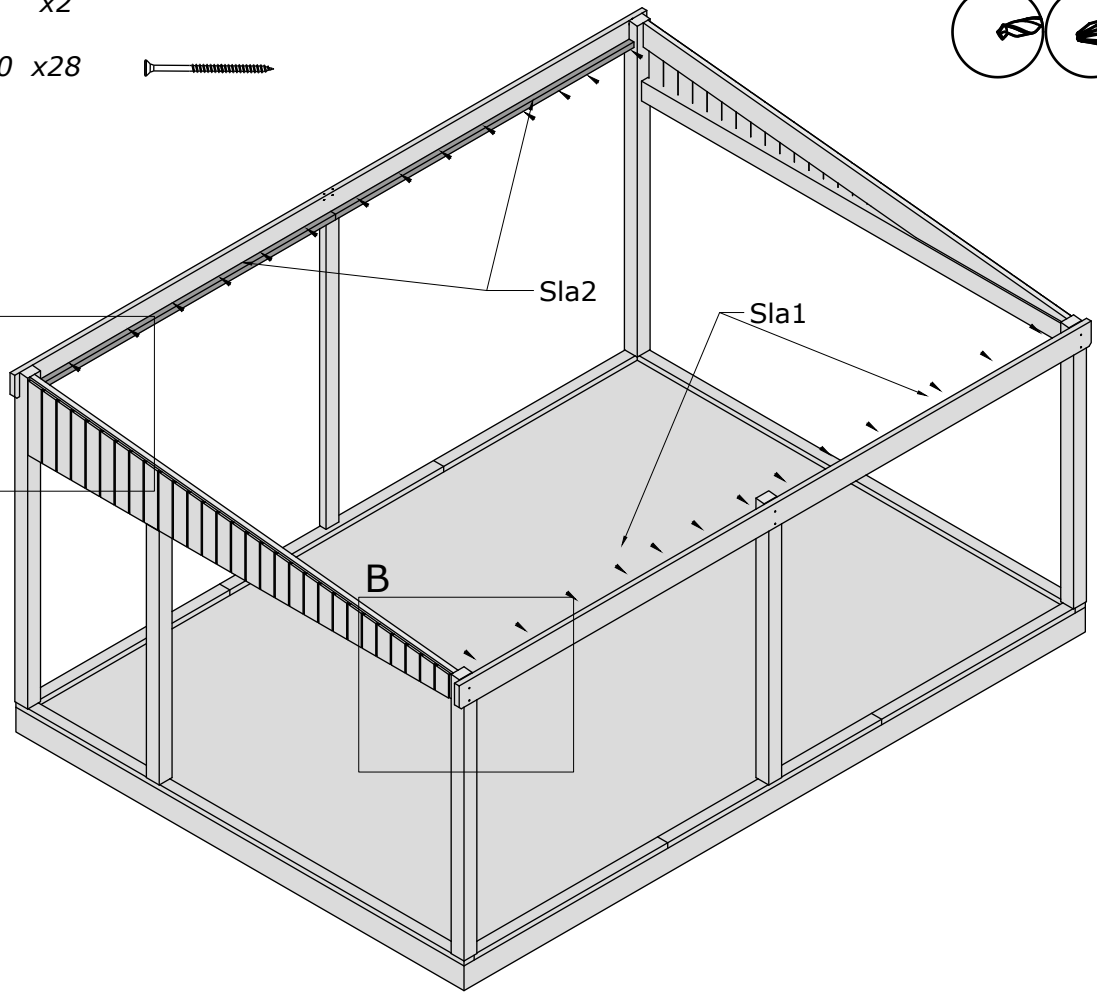
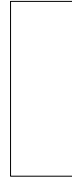

Sla2

Sla1

B

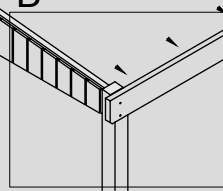

A

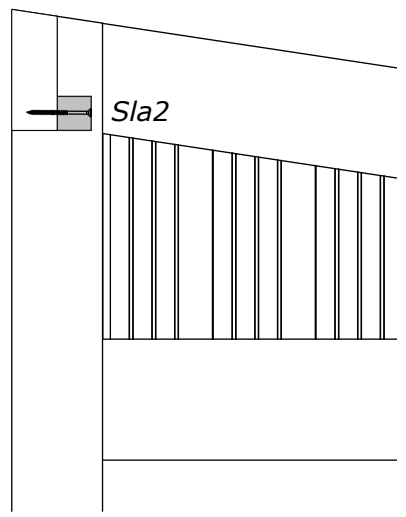

Sla2

B

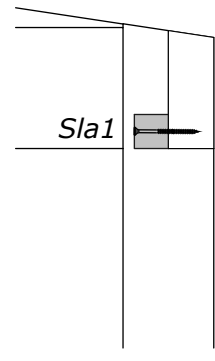

Sla1

RoR1 x12

Ø8x260 x48

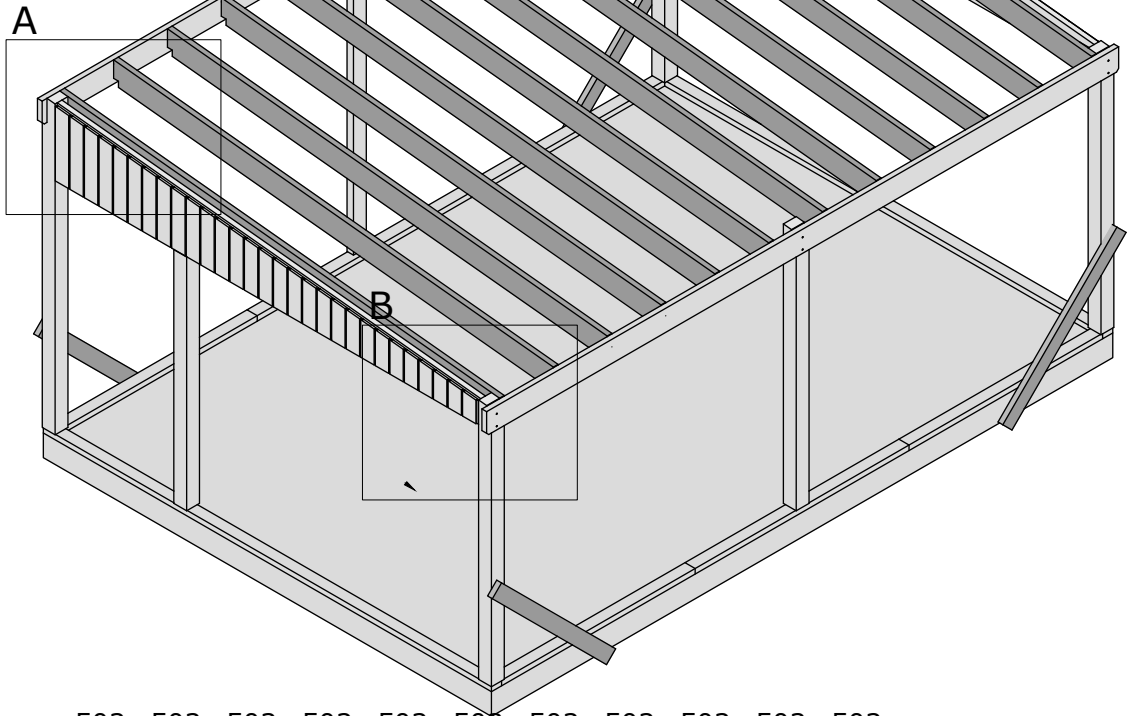
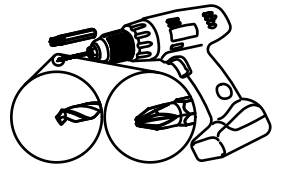

503 503 503 503 503 503 503 503 503 503 503

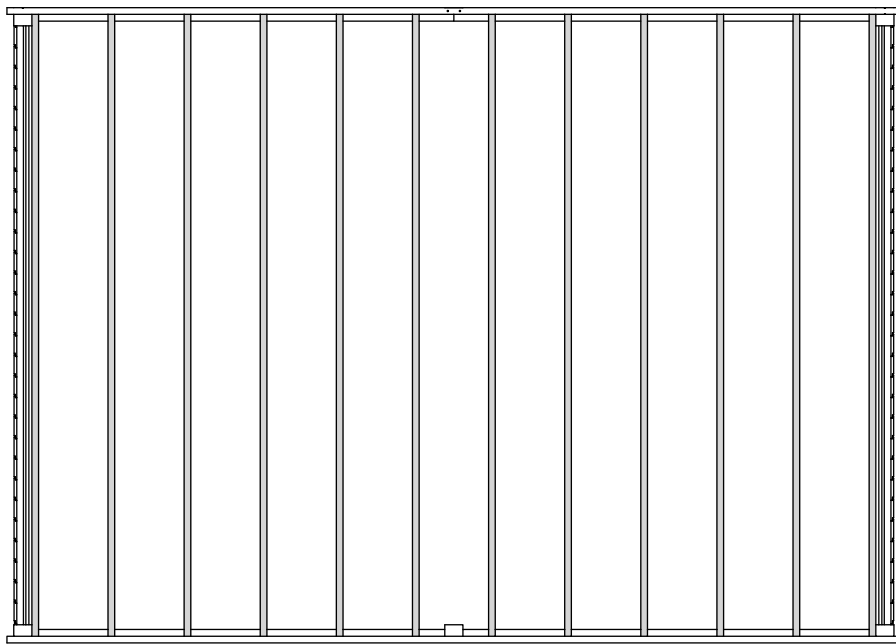

A

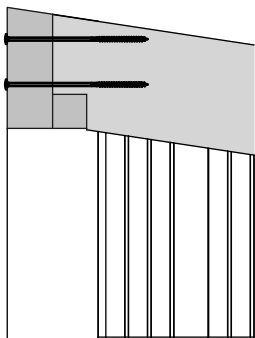

B

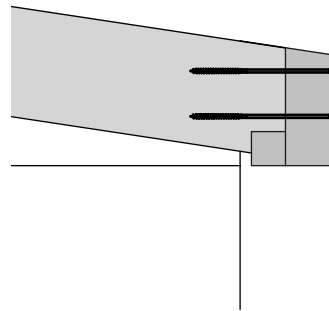

Sla4 x2

Ø5x80 x14 

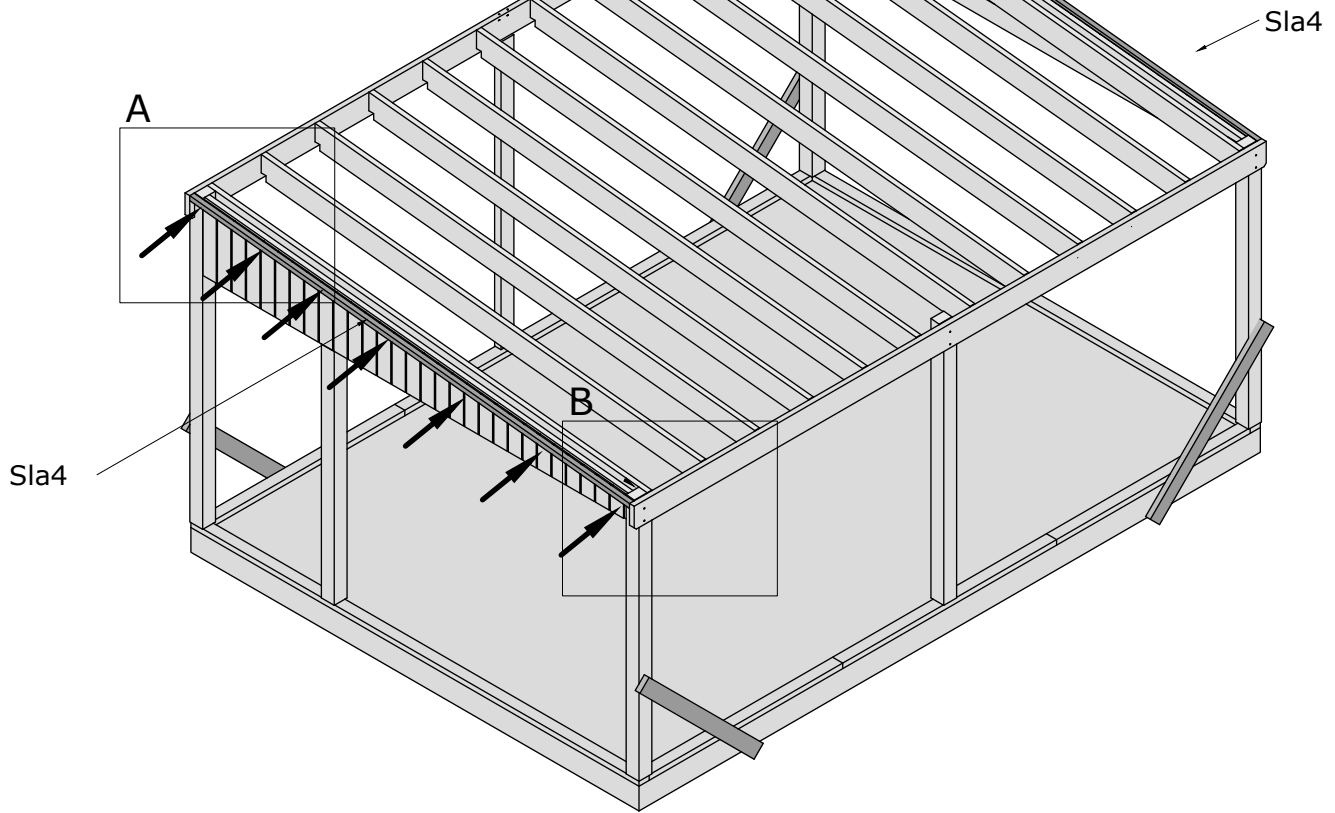
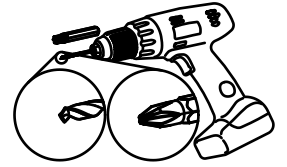

A

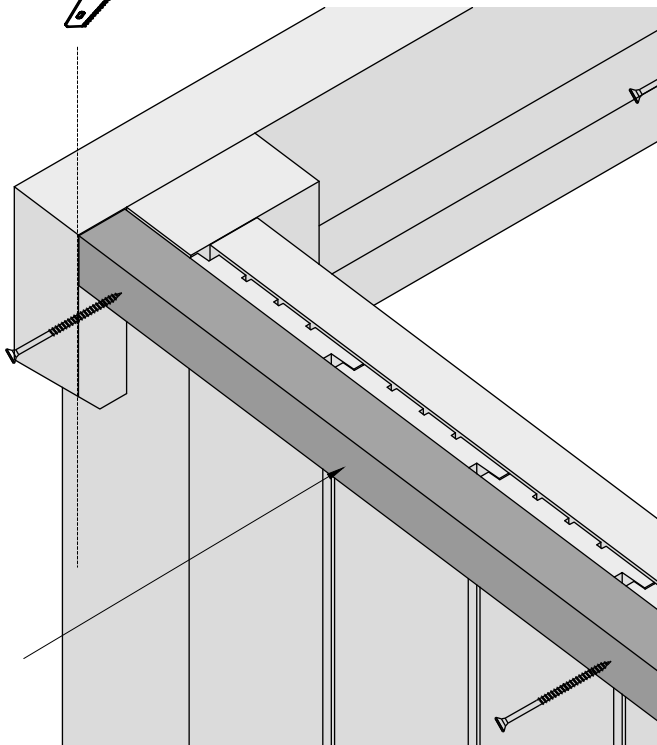
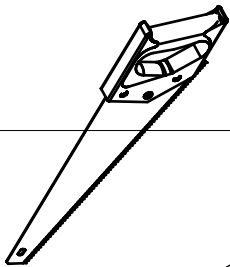

B

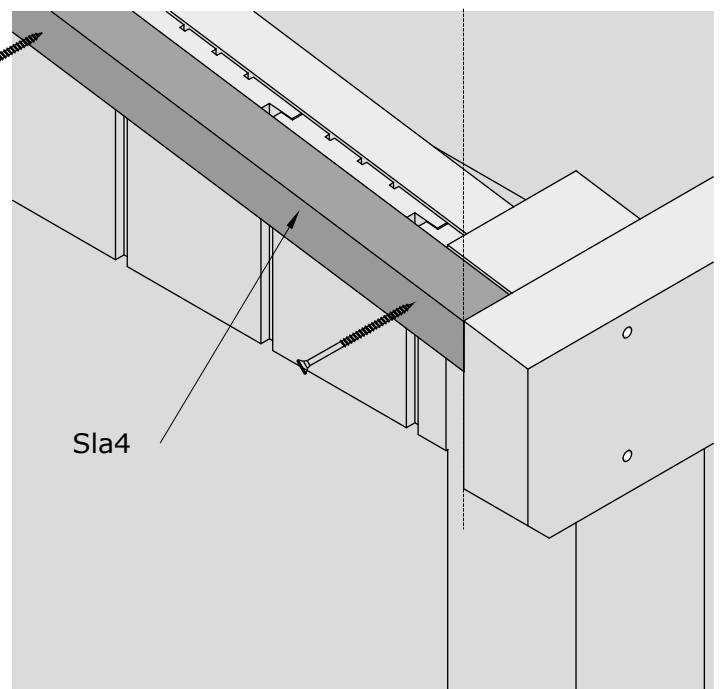
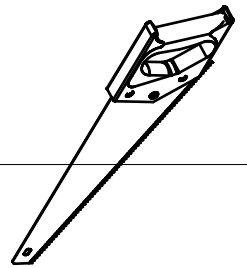

RB2-1 x51
RB2-2 x51
Ø2,2x50 x650

2704 mm

3206 mm

A

B

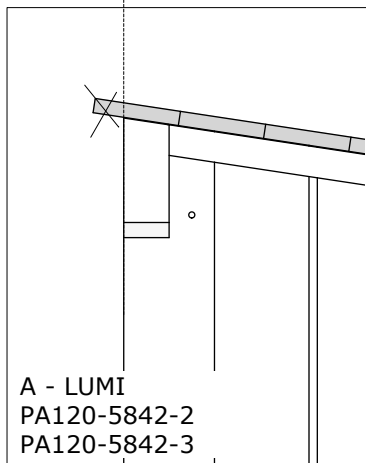
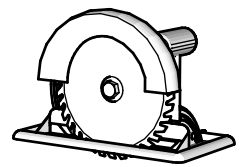
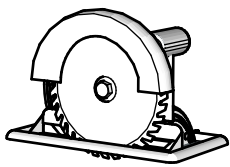
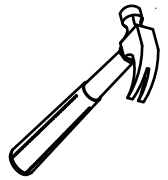

A - LUMI
PA120-5842-2
PA120-5842-3

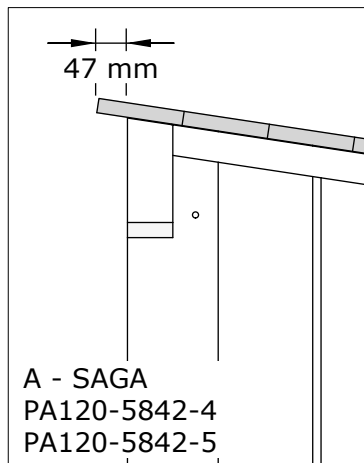

A - SAGA
PA120-5842-4
PA120-5842-5

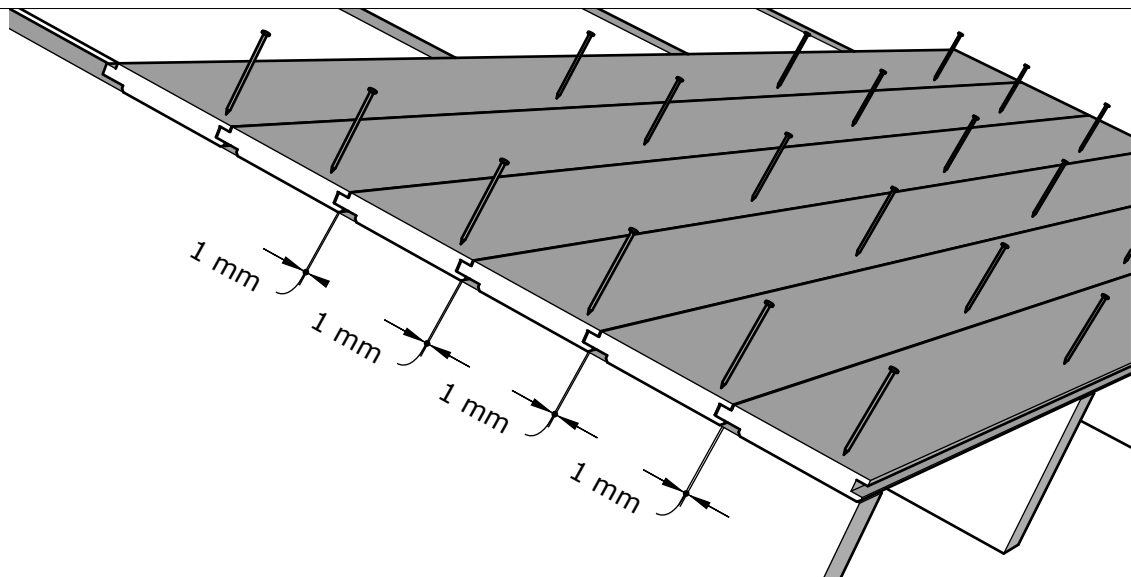
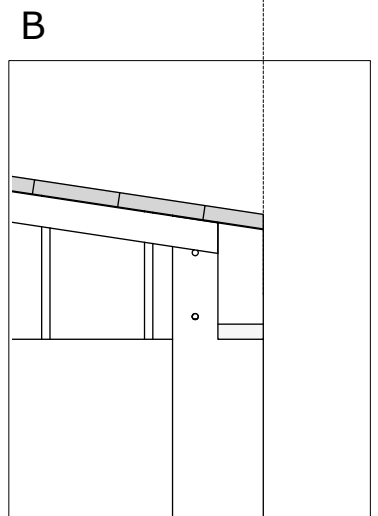

WG10 x3

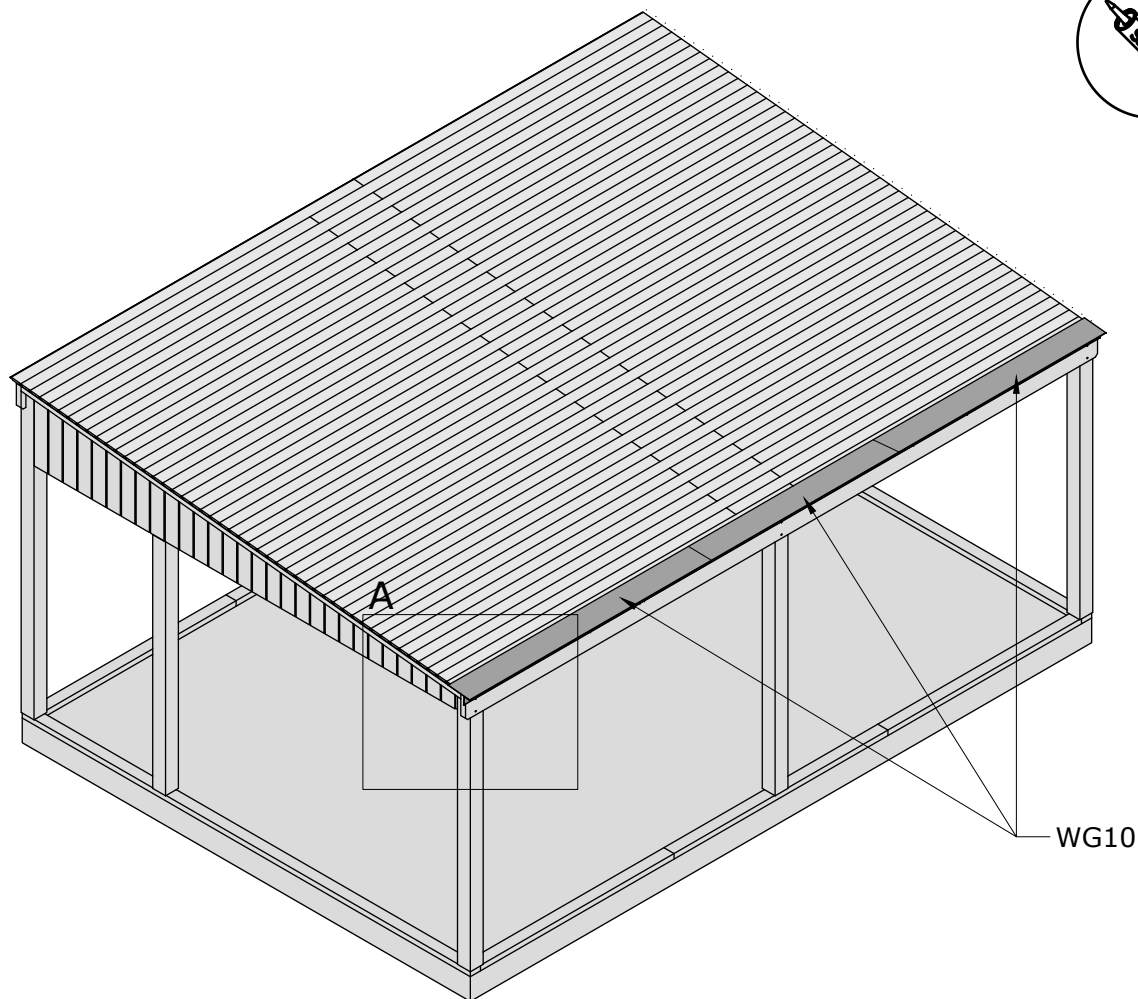
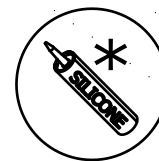

A

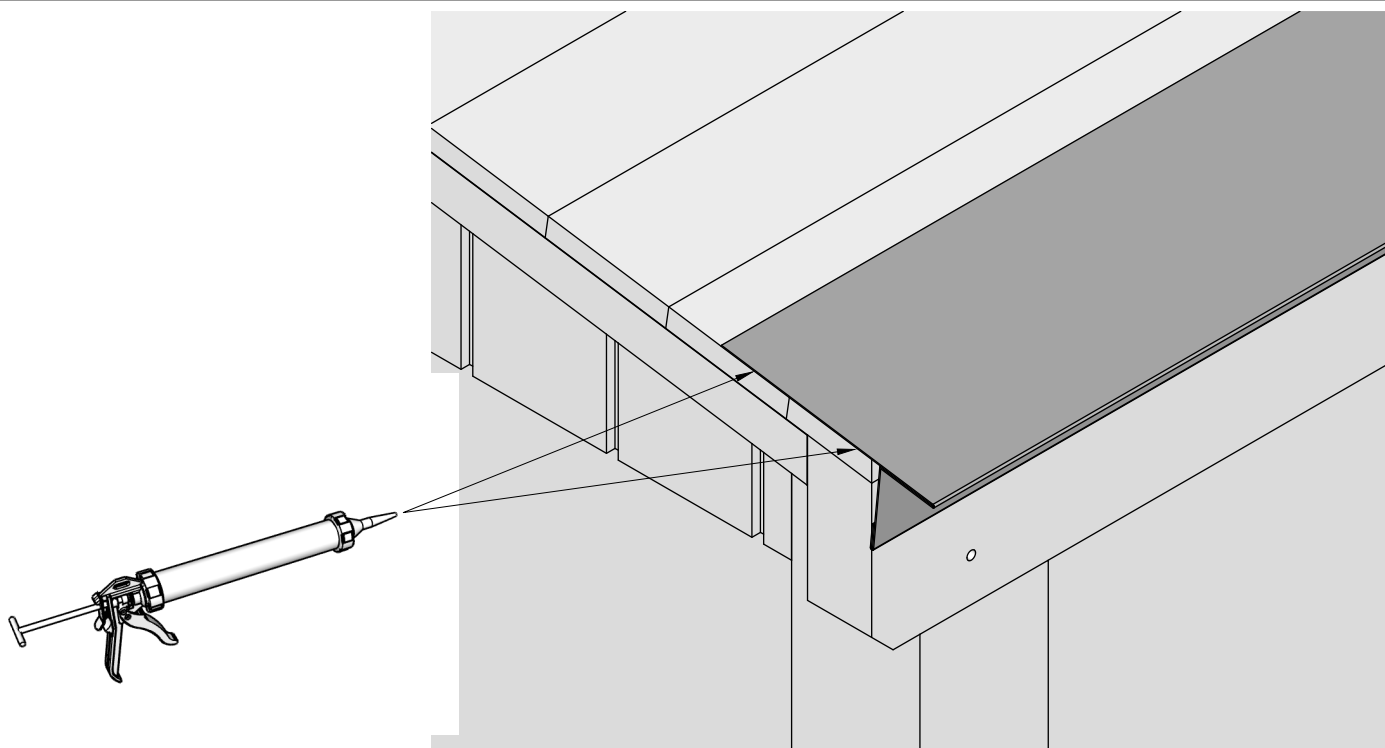

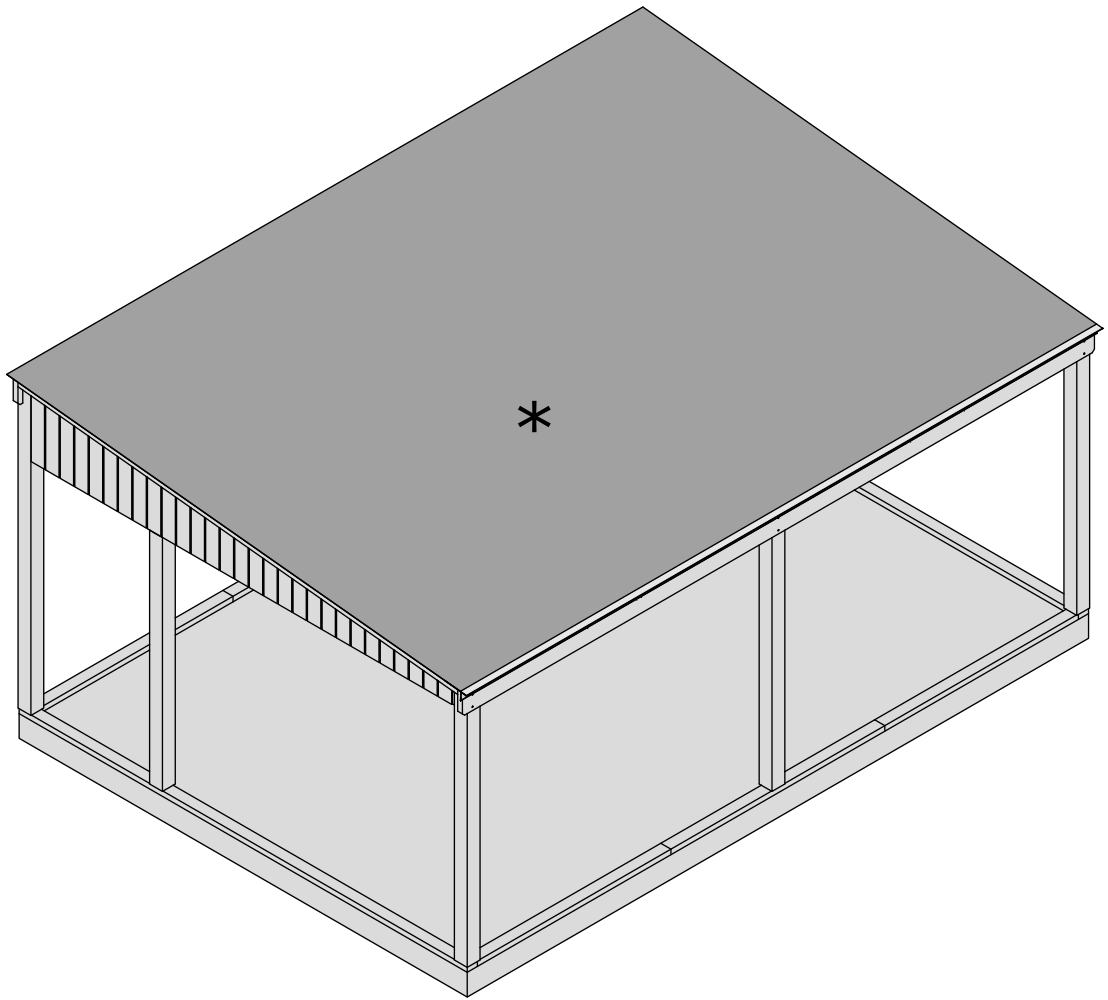

EaE1 x1 (SAGA)

WG12-1 x8

Ø4,5x60 x10

Ø4,8x28 x33

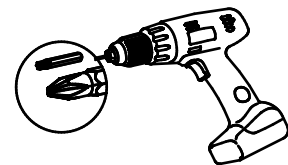
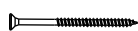

SAGA: EaE1 + WG12

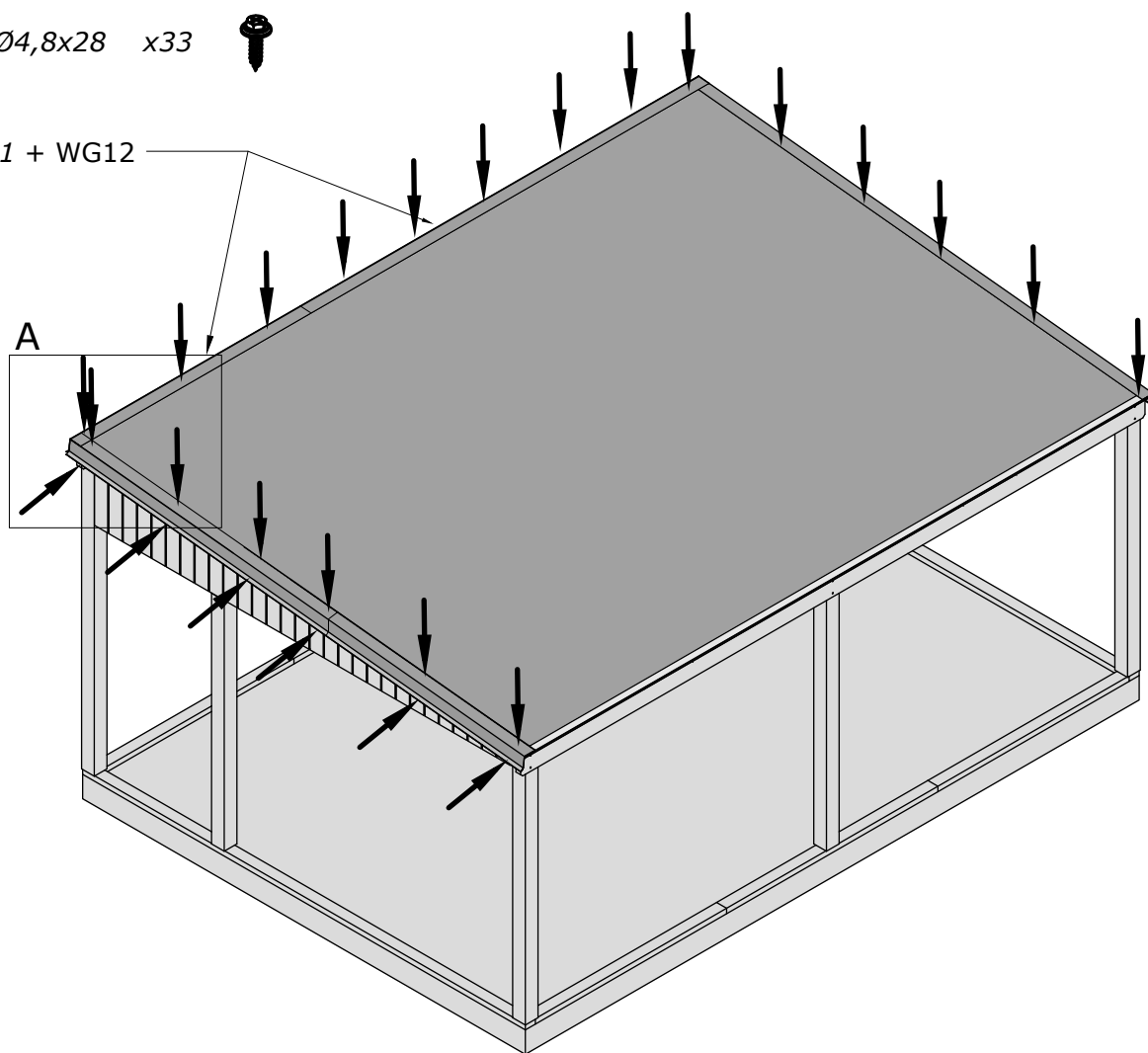

A - LUMI
PA120-5842-2
PA120-5842-3

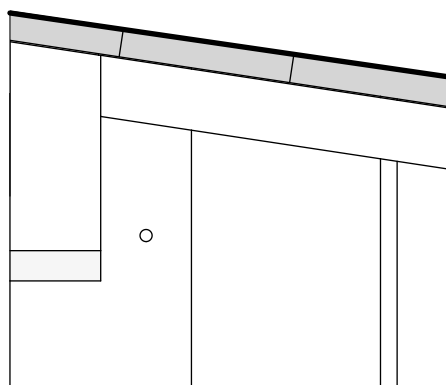

A - SAGA
PA120-5842-4
PA120-5842-5

WG12-1

EaE1

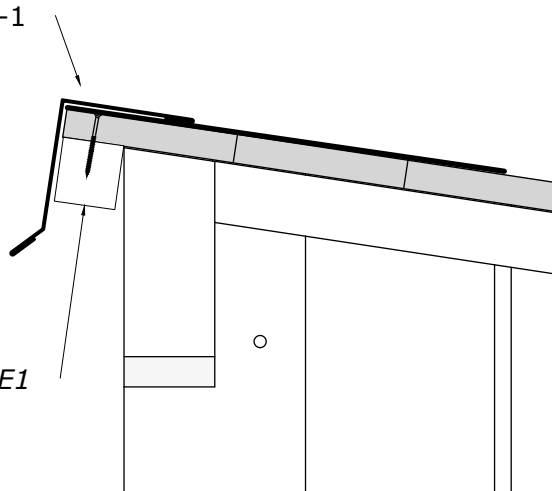

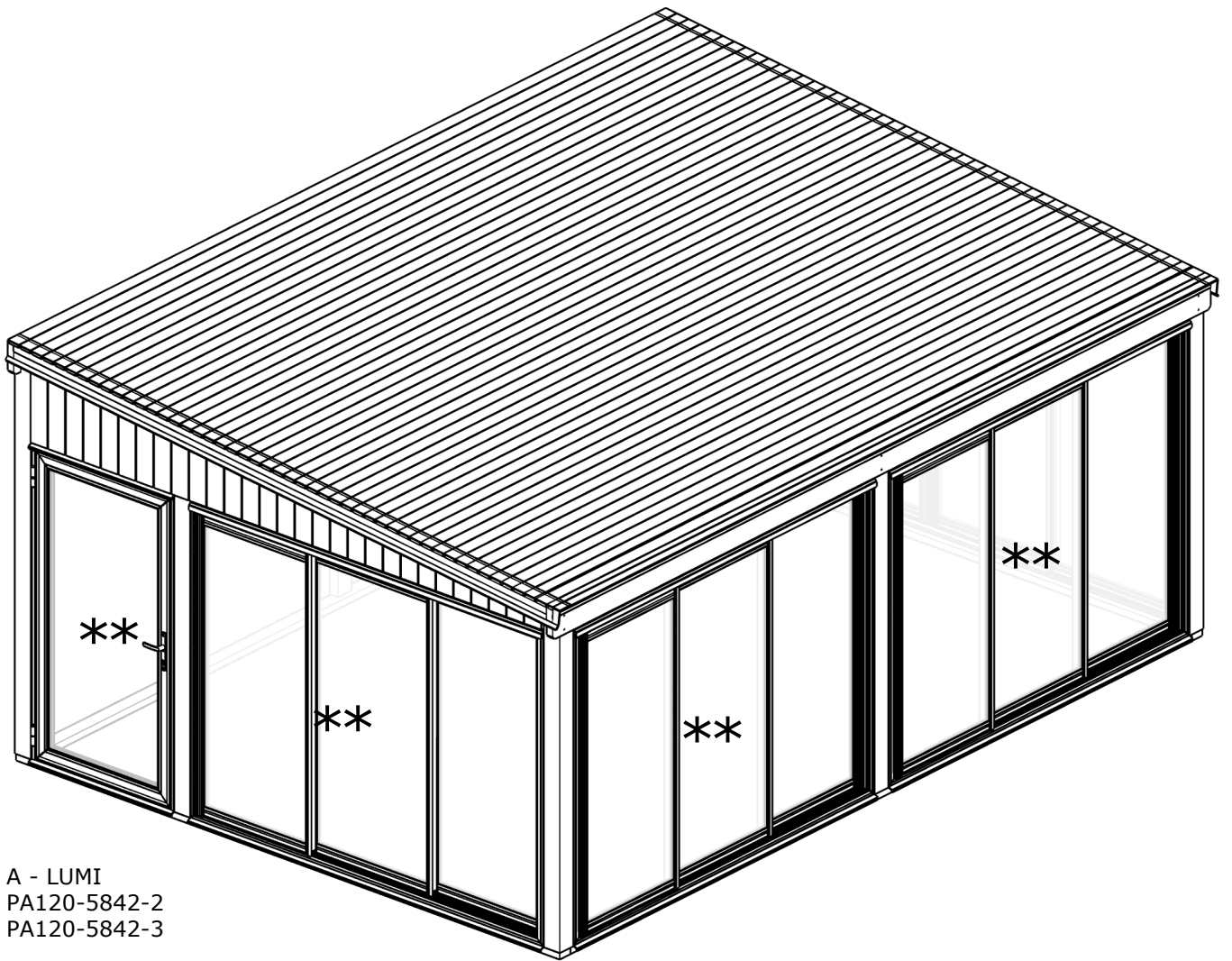

A - LUMI
PA120-5842-2
PA120-5842-3

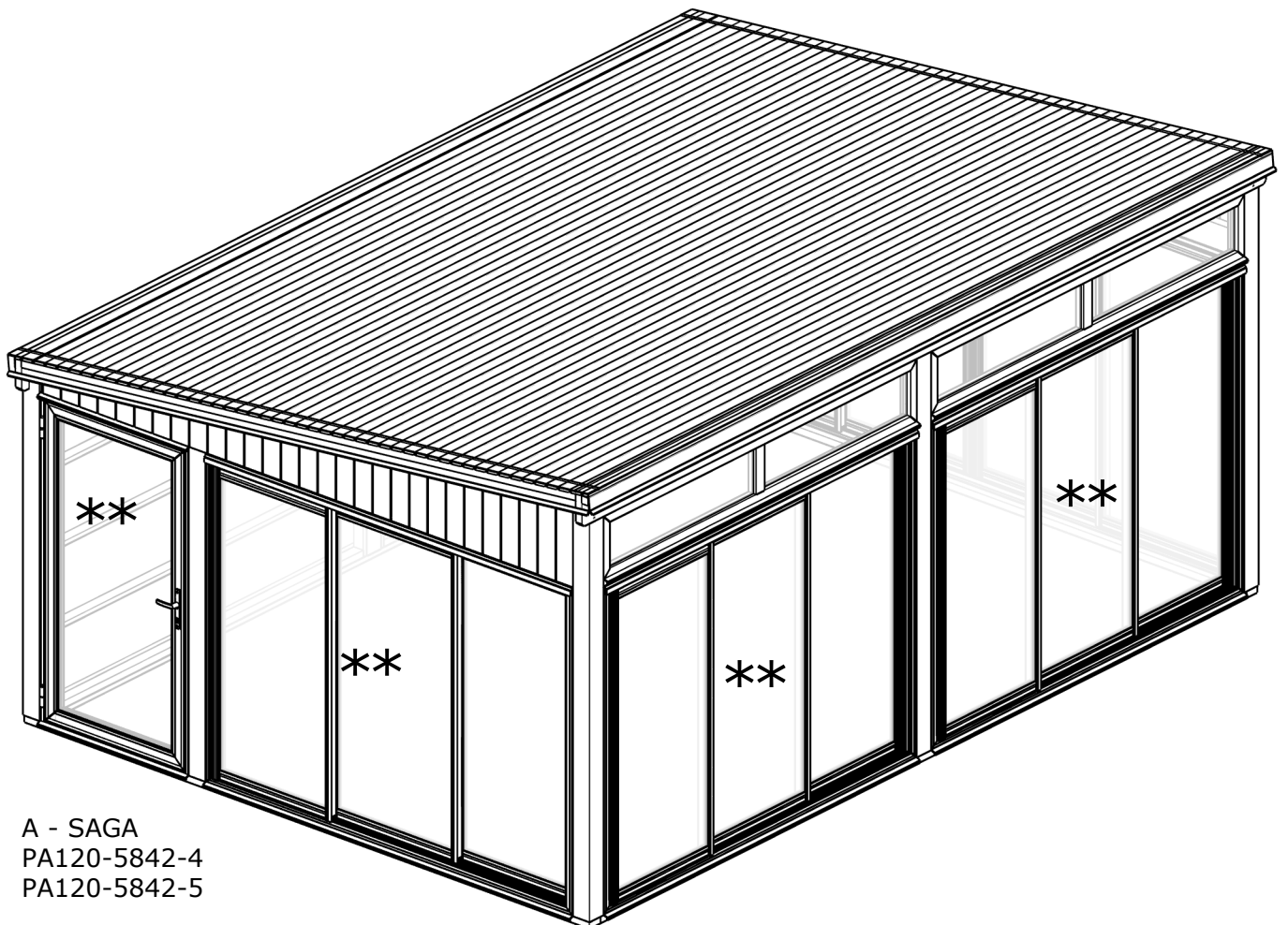

A - SAGA
PA120-5842-4
PA120-5842-5