

Assembly, installation and maintenance manual

Montage-, Aufbau- und Wartungsanleitung • Assemblage, manuel de montage et d'entretien • Montaje, instalación y mantenimiento • Manuale di montaggio, installazione e manutenzione • Monterings- og vedlikeholdsmanual • Monterings-, installations- och underhållsmanual • Kokoamis-, asennus- ja huolto-ohje • Vejledning for montering og vedligehold • Handleiding voor montage, installatie en onderhoud • Manual de montagem, instalação e manutenção • Návod k montáži, instalaci a údržbě • Instrukcja montażu, instalacji i konserwacji • Surinkimo, montavimo ir priežiūros vadovas • Montāžas, uzstādīšanas un apkopes rokasgrāmata • Руководство по сборке и обслуживанию • Montaaži-, paigaldus- ja säilitamise juhend



Element house EL16-2737

<p>Factory inspection by • Werkskontrolle durch • Contrôle à partir de l'usine par • Inspector de fábrica • Collaudato da • Fabrikkontroll utført av • Fabriksbesiktigat av • Tehtaan tarkastaja • Fabriks Kontrol udført af • Fabriekscontrole door • Inspeção de fábrica, por: • Zkontrolováno ve výrobním závodě • Kontrola fabryczna do • Apžiūrą gamykloje atliko Rūpnīcas pārbaudi veicis • Заводской контроль • Tehase kontroll teostatud:</p> <p>.....</p>	<p>Date • Datum • Date • Fecha • Data • Dato • Datum • Päiväys • Dato • Datum • Data • Datum • Data • Datums • Data • Дата • Kuupäev:</p> <hr/> <p>Pack number • Pack Nr. • Packet n° • Bulto N° • Pacco N. • Serienr • Produktionsnummer • Pakettinro • Pakke nr. • Pak nr. • Número de embalagem • Číslo balení • Numer opakowania • Pakotės numeris • Iepakojuma numurs • Упаковочный номер • Pakinumber:</p>
---	--



www.palmako.ee/information-hub

English: Before installing and using the product, please read the instructions and warranty terms at www.palmako.ee/information-hub to guarantee proper installation and long-lasting performance.

Deutsch: Wichtig! Bitte vor Aufbau und Nutzung des Produkts unbedingt die detaillierte Montageanleitung sowie die Garantiebedingungen unter www.palmako.ee/information-hub lesen, um eine fachgerechte Montage und eine lange Funktionssicherheit zu gewährleisten.

Français: Avant d'installer et d'utiliser le produit, veuillez lire les instructions et les conditions de garantie sur www.palmako.ee/information-hub afin de garantir une installation correcte et la longévité du produit.

Español: Antes de instalar y utilizar el producto, lea las instrucciones y las condiciones de garantía en www.palmako.ee/information-hub para asegurar una instalación correcta y una larga vida útil del producto.

Italiano: Prima di installare e utilizzare il prodotto, leggere le istruzioni e le condizioni di garanzia su www.palmako.ee/information-hub per garantire una corretta installazione e prestazioni durature.

Norsk: Før montering og bruk av produktet, vennligst les monteringsanvisningene og garantivilkårene på www.palmako.ee/information-hub for å sikre korrekt montering og fremtidig holdbarhet.

Svenska: Innan du installerar och använder produkten, vänligen läs instruktionerna och garantivillkoren på www.palmako.ee/information-hub för att säkerställa korrekt installation och produktens långvariga hållbarhet

Suomi: Ennen tuotteen asentamista ja käyttämistä, lue ohjeet ja takuehdot osoitteessa www.palmako.ee/information-hub varmistaaksesi oikean asennuksen ja pitkäkestoisen toiminnan.

Русский: Перед установкой и использованием изделия ознакомьтесь с инструкцией и условиями гарантии на сайте www.palmako.ee/information-hub, чтобы гарантировать правильную установку и долговечность изделия.

Eesti: Enne toote paigaldamist ja kasutuselevõttu lugege palun juhiseid ja garantiitingimusi aadressil www.palmako.ee/information-hub, et tagada nõuetekohane paigaldus ja toote pikk eluiga.

Dansk (Oversat af AI): Læs venligst instruktionerne og garantibetingelserne på www.palmako.ee/information-hub, før du installerer og bruger produktet, for at garantere korrekt installation og langvarig ydeevne.

Dutch (Vertaald door AI): Lees vóór de installatie en het gebruik van het product de instructies en garantievoorwaarden op www.palmako.ee/information-hub om een correcte installatie en langdurige werking te garanderen

Português (Traduzido por IA): Antes de instalar e utilizar o produto, leia as instruções e os termos de garantia em www.palmako.ee/information-hub para garantir uma instalação adequada e um desempenho duradouro.

Čeština (Přeloženo umělou inteligencí): Před instalací a použitím produktu si prosím přečtěte pokyny a záruční podmínky na www.palmako.ee/information-hub, abyste zaručili správnou instalaci a dlouhodobý výkon.

Polski (Przetłumaczone przez AI): Przed zainstalowaniem i użyciem produktu należy przeczytać instrukcję oraz warunki gwarancji dostępne na stronie www.palmako.ee/information-hub, co pozwoli zagwarantować prawidłową instalację i długotrwałą wydajność.

Latviešu (Mākslīgā intelekta tulkojums): Pirms produkta uzstādīšanas un lietošanas, lūdzu, izlasiet instrukcijas un garantijas noteikumus vietnē www.palmako.ee/information-hub, lai garantētu pareizu uzstādīšanu un ilgstošu darbību.

Lietuviškai (Išvertė DI): Prieš montuodami ir naudodami gaminį, perskaitykite instrukcijas ir garantijos sąlygas adresu www.palmako.ee/information-hub, kad užtikrintumėte tinkamą montavimą ir ilgalaikį veikimą.

273

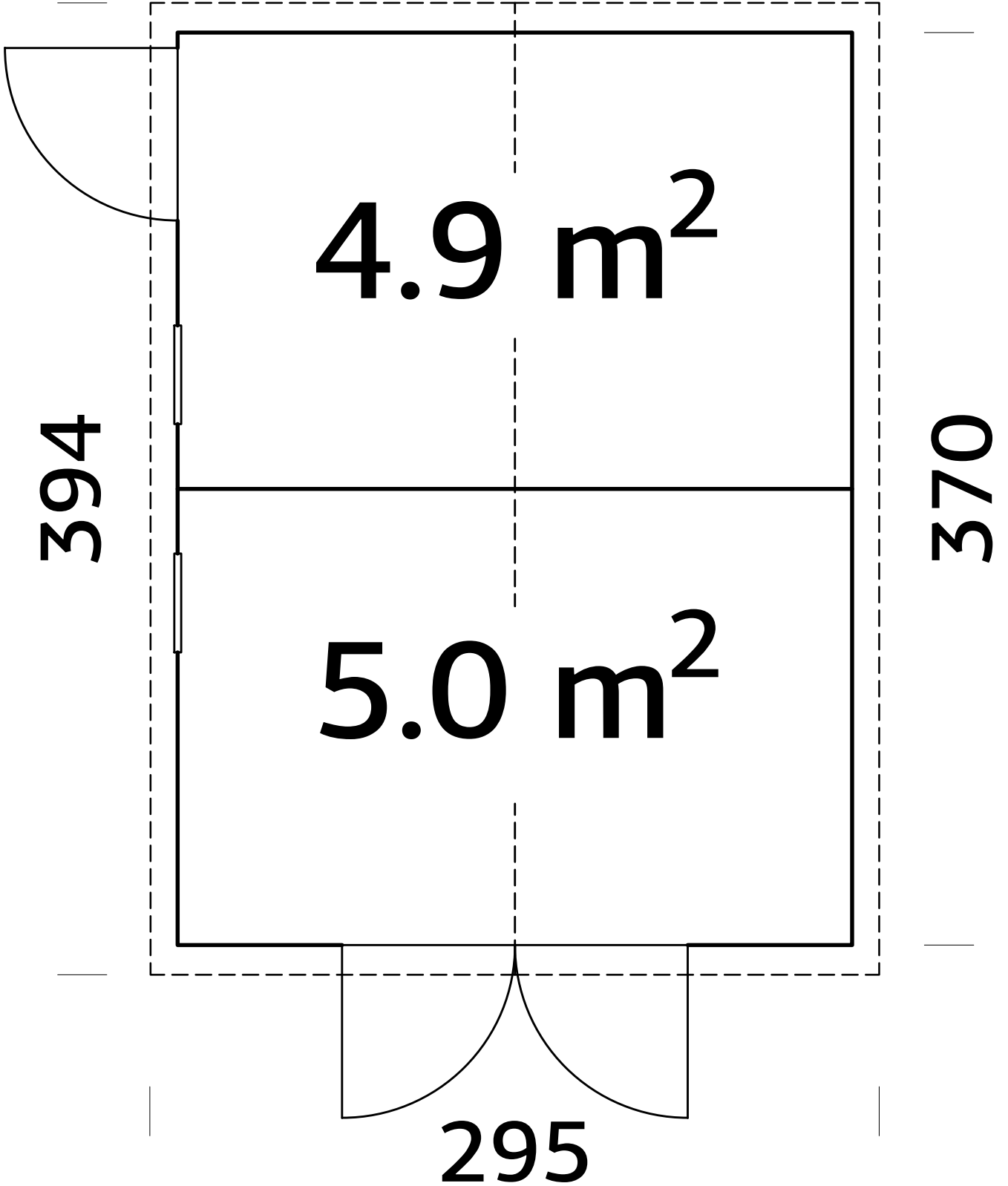

4.9 m^2

5.0 m^2

394

370

295

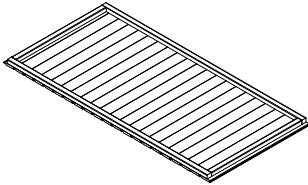
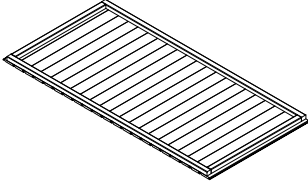
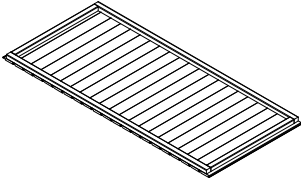
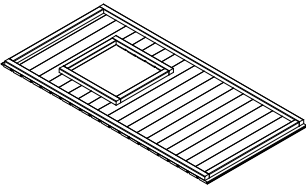
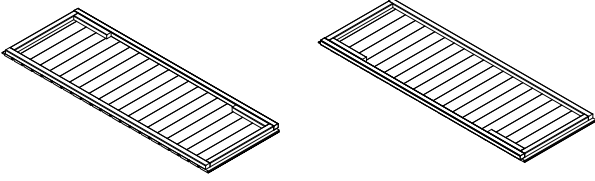
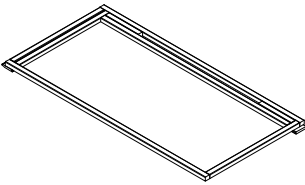
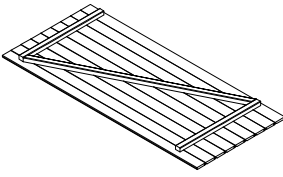
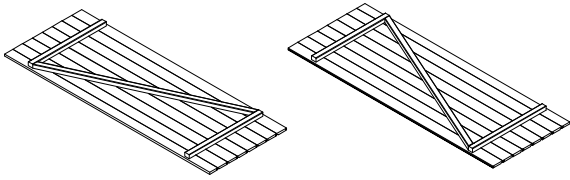
Pos	05.05.2026 SPECIFICATION-STÜCKLISTE-NOMENCLATURE-ELEMENTI-ESPECIFICACIÓN EL16-2737	1/3	Pcs	Profile (mm)	Length (mm)
1			8	1870X900	48
2			2	1845X900	48
3			1	1845X836	48
4			2	1870X900	48
5L+5R			1+1	1870X655	48
6			1	1870X900	48
7			1	1770X800	48
8R+8L			1+1	1864X700	48

Pos	05.05.2026 SPECIFICATION-STÜCKLISTE-NOMENCLATURE-ELEMENTI-ESPECIFICACIÓN EL16-2737	2/3	Pcs	Profile (mm)	Length (mm)
9R+9L			3+3	1350X370	48
10	Foundation- Fundament- Fondation- Fondazione- Vigas de cimentación 		18	40x32	1350
11	Foundation- Fundament- Fondation- Fondazione- Vigas de cimentación 		9	40x32	430
12	Rafter- Sparre- Chevron- Trave- Cabrio 		8	80x19	1560
13	Rafter- Sparre- Chevron- Trave- Cabrio 		4	80x19	780
14	Rafter- Sparre- Chevron- Trave- Cabrio 		4	70x45	1776
15	Floor board- Fussbodenbrett- Madrier du plancher - Tavola pavimento- Tabla de suelo 		49 62	114x16 89x16	1832 1832
16	Roof board- Dachbrett- Madrier du toit- Tavola tetto- Tabla de tejado 		69 88	114x16 89x16	1530 1530
17	Slat- Leiste- Baguette- Listello- Listón 		3	40x32	296
18	Slat- Leiste- Baguette- Listello- Listón 		3	95x16	275
19	Facia board- Giebelblende- Écran frontal- Schermo frontone- Tabla de facia 		4	95x16	1550
20	Covering board- Deckbrett- Madrier de couverture- Tavola di copertura- Listón de cubierta 		4	45x16	1550
21	Eave edging- Dachrandbrett- Madrier en bordure du toit- Tavola bordo tetto- Tabla de valadizo 		4	45x16	1560
22	Eave edging- Dachrandbrett- Madrier en bordure du toit- Tavola bordo tetto- Tabla de valadizo 		2	45x16	780
23	Slat- Leiste- Baguette- Listello- Listón 		2	45x16	912
24	Slat- Leiste- Baguette- Listello- Listón 		2	45x16	864
25	Side slat- Randleiste- Baguette en bordure- Listón de borde- Listello bordo 		4	95x16	1900
26	Side slat- Randleiste- Baguette en bordure- Listón de borde- Listello bordo 		4	95x16	1890
27	Side slat- Randleiste- Baguette en bordure- Listón de borde- Listello bordo 		9	95x16	1790
28	Diamond- Deckbrett- Madrier- Tavola di copertura- Rombo- 16x95 		2	16x95	300
Fim	-Fixing kit- Befestigungsset- Moyens de fixation- Materiale di fissaggio- Kit de fijación		1		
A	Screw- Schraube- Vis- Vite- Tornillo- 4.5x70mm 		125		
B	Screw- Schraube- Vis- Vite- Tornillo- 4.5x60mm 		36		

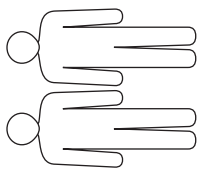

Ø6
Ø3

M10

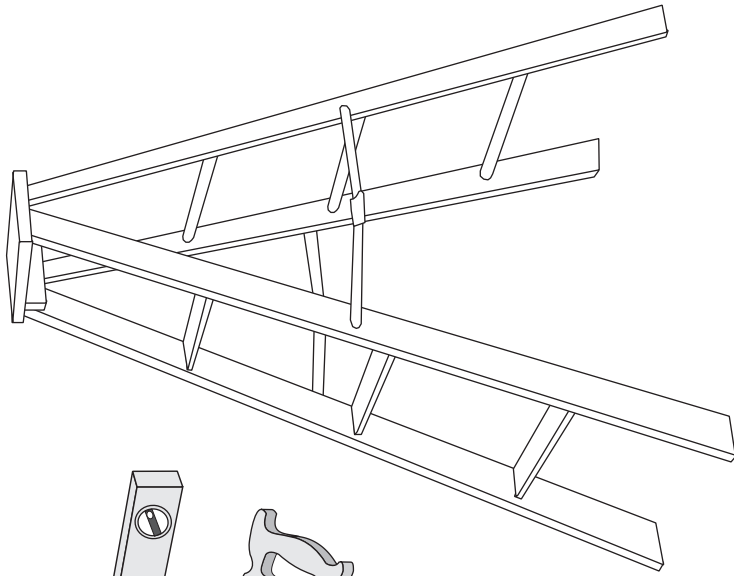
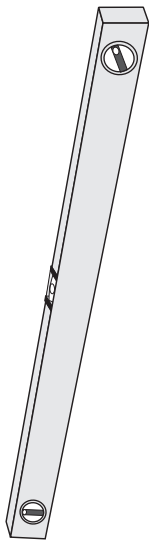
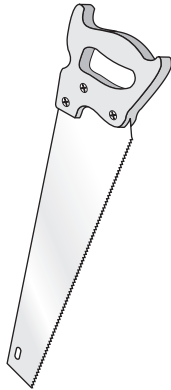
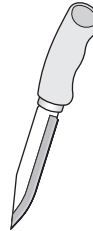
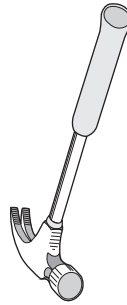
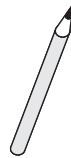
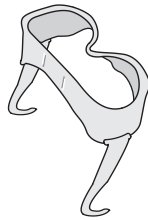
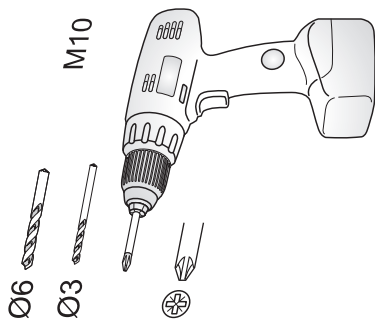

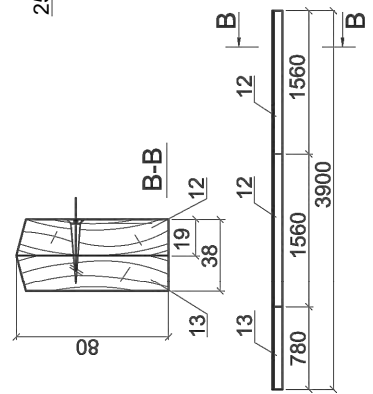
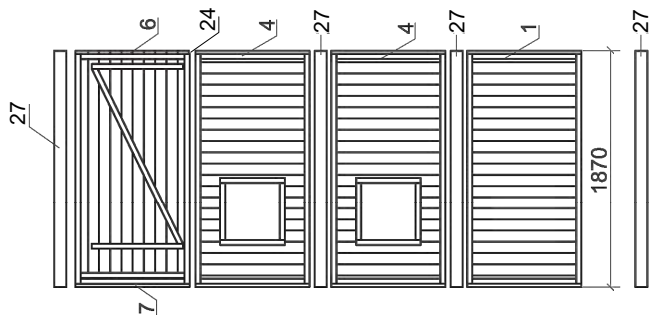
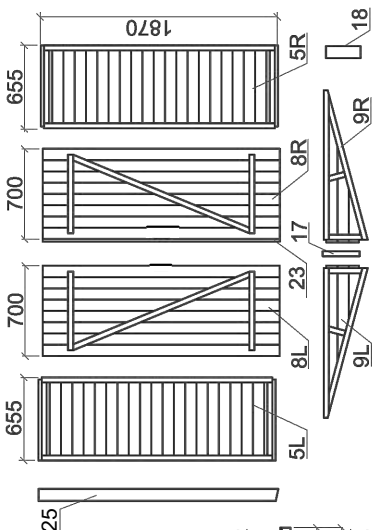
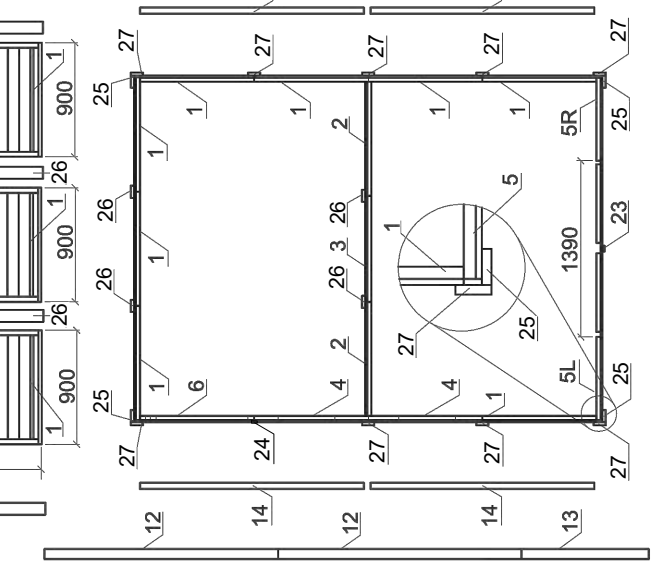
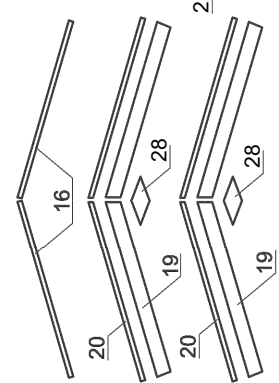
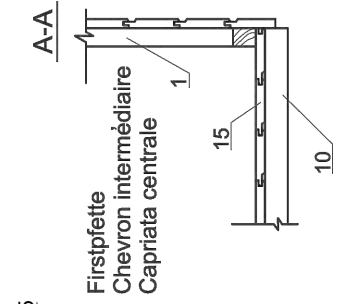
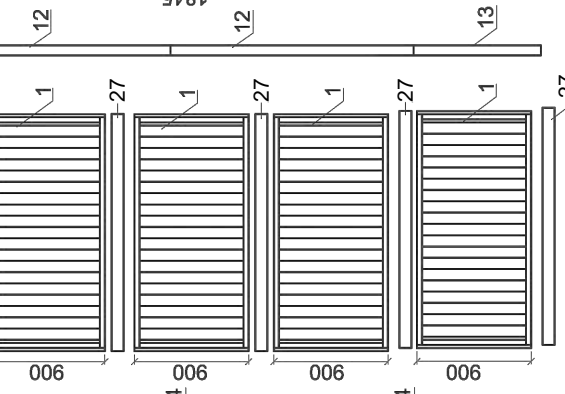
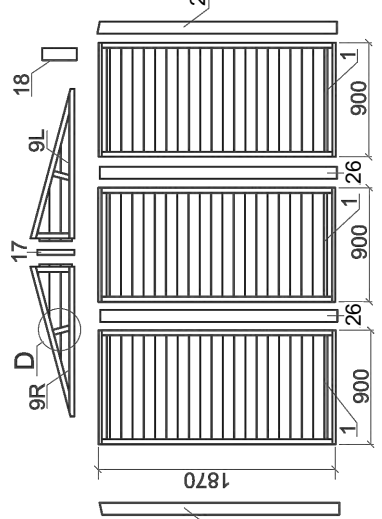
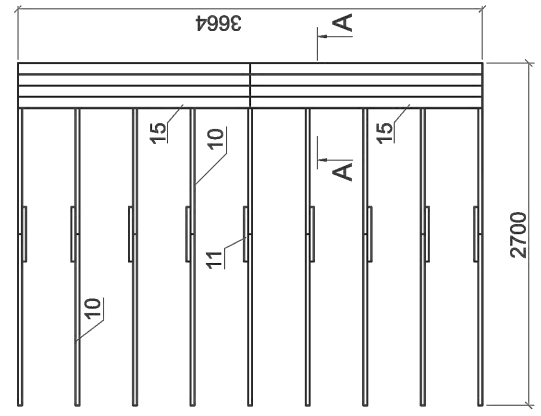
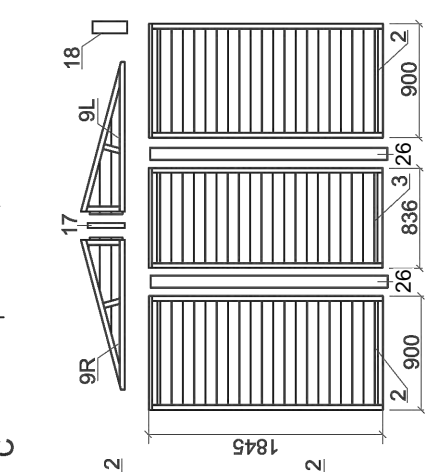
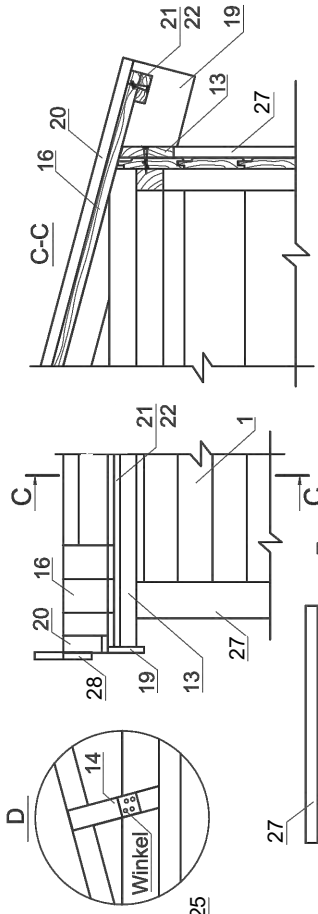

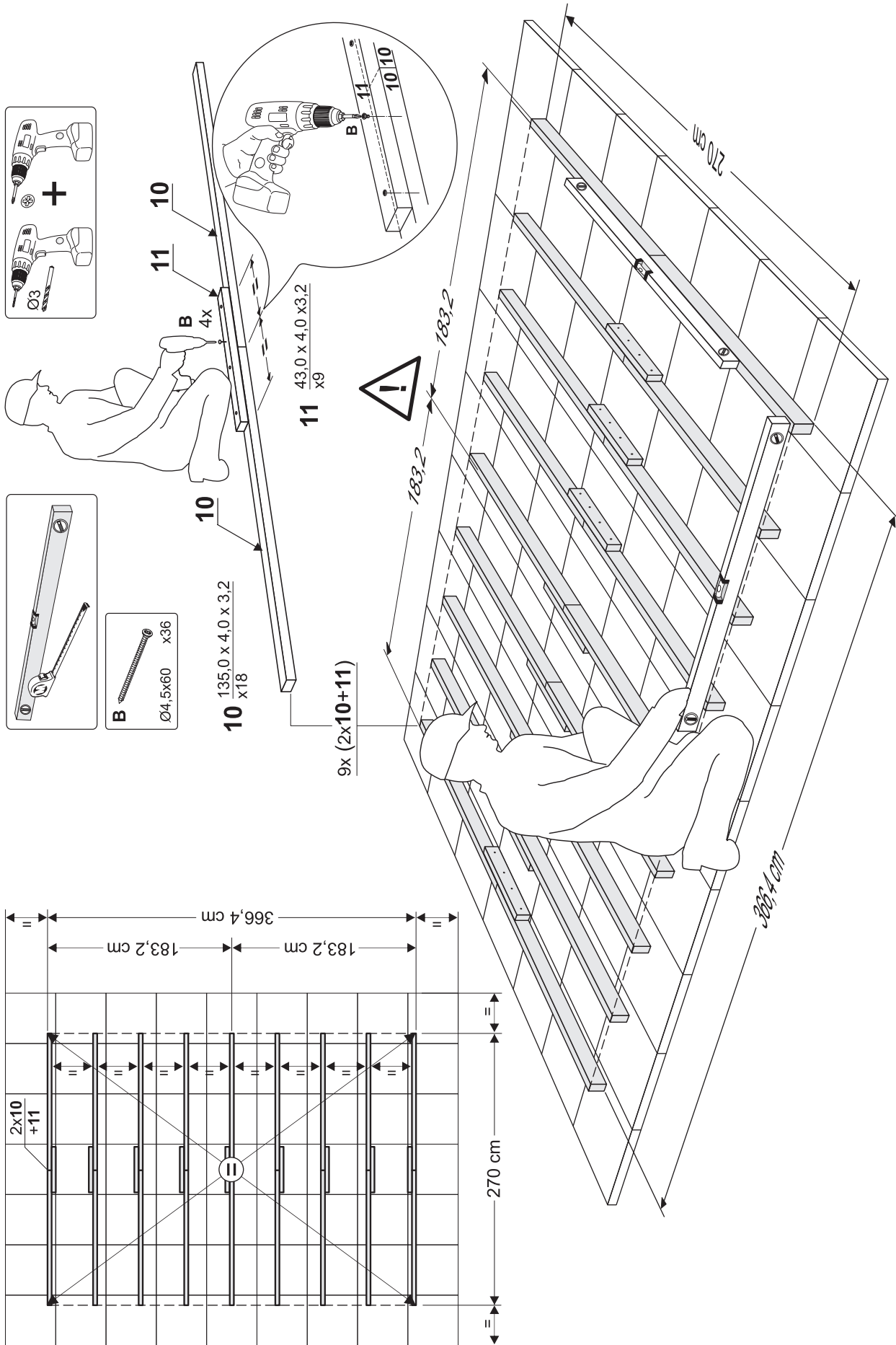

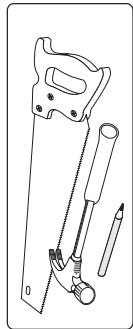
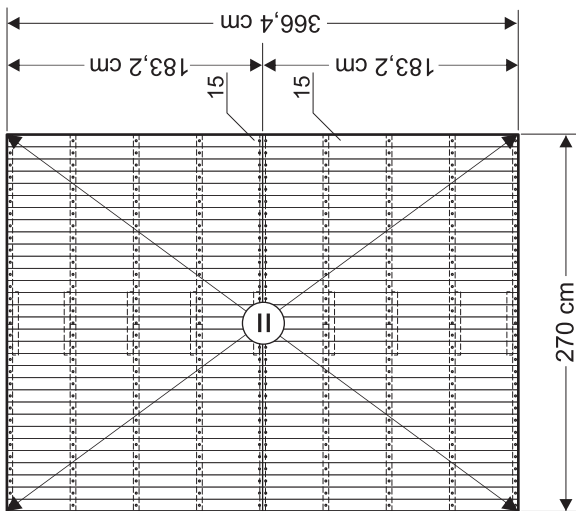

H
 Ø2,5x50 x310

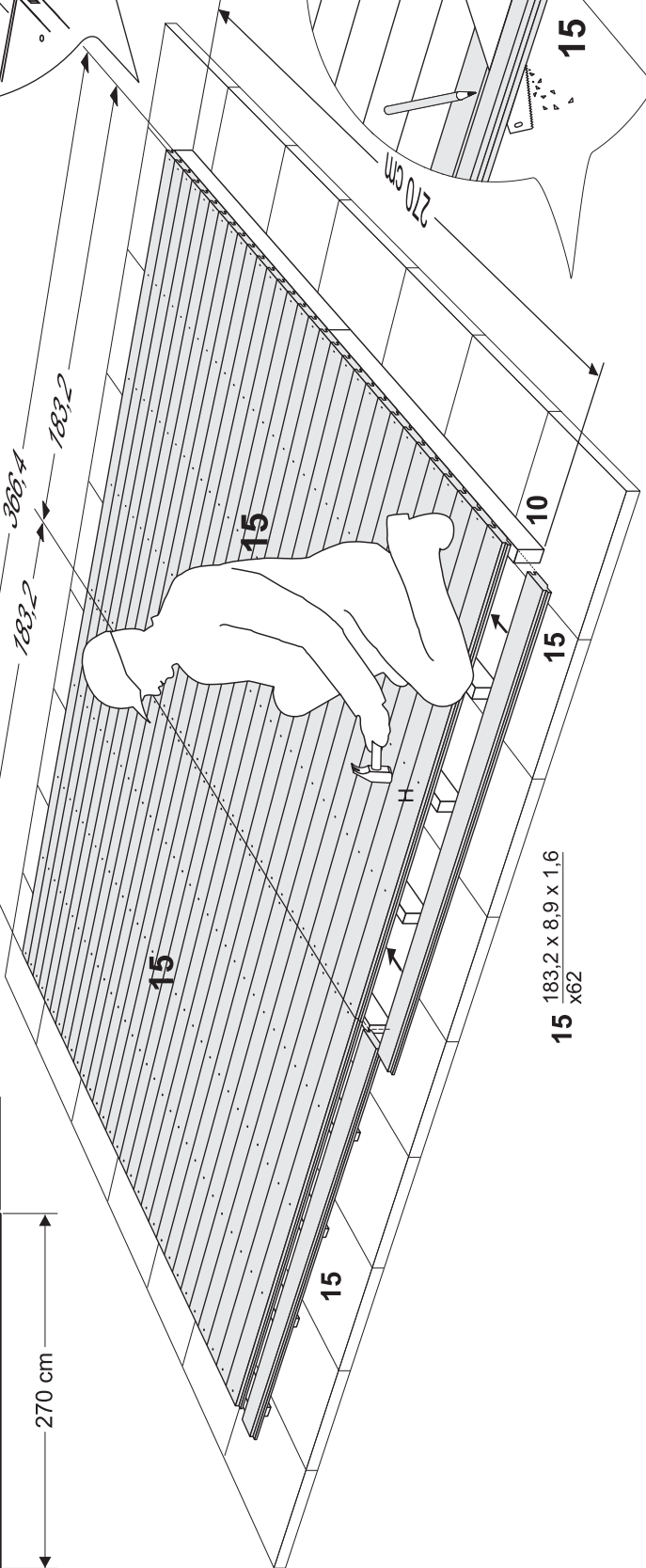
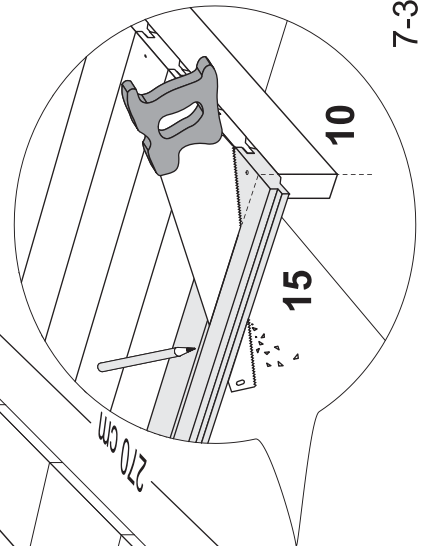
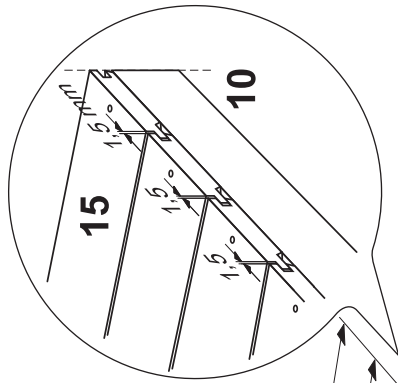

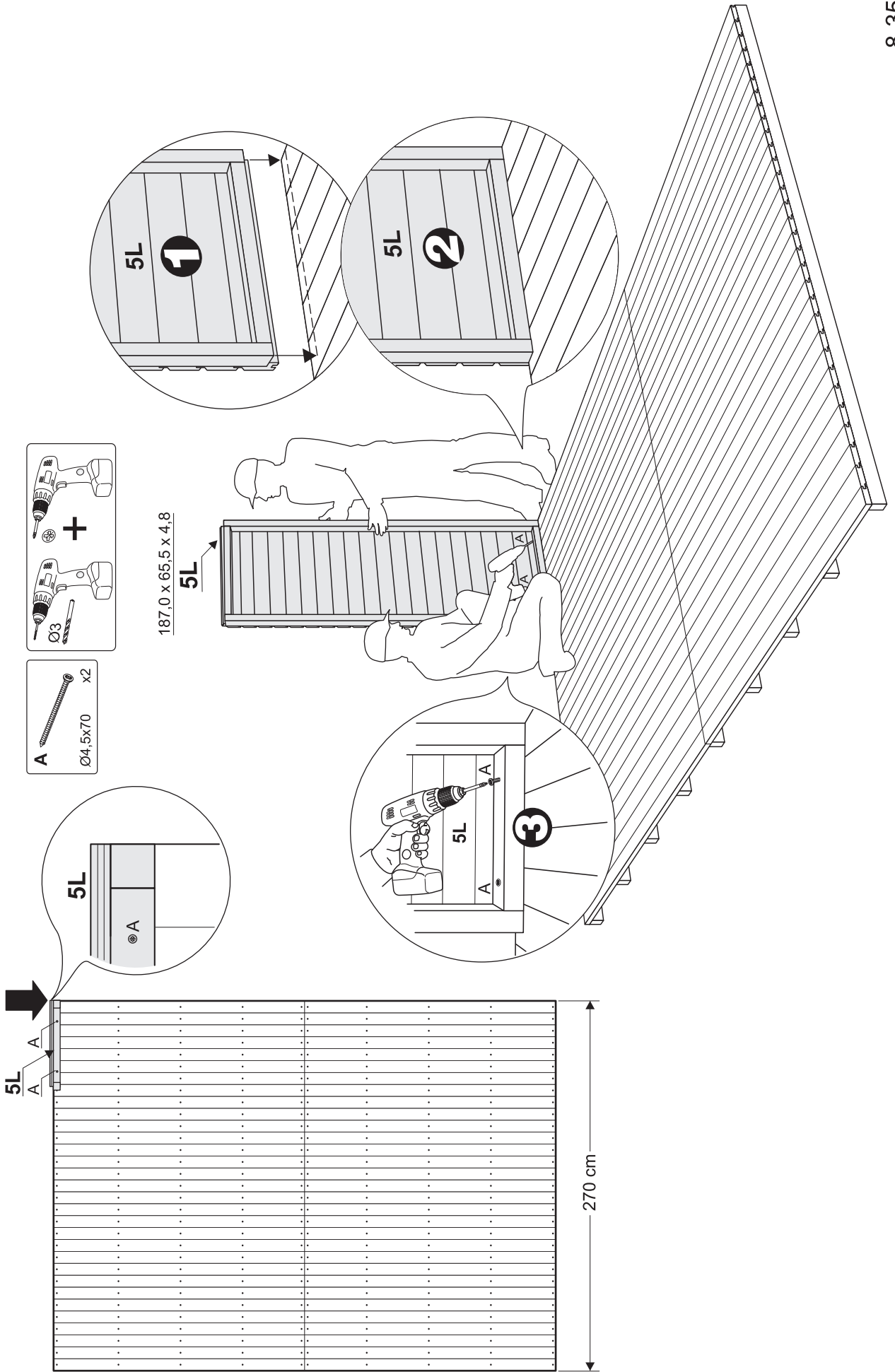

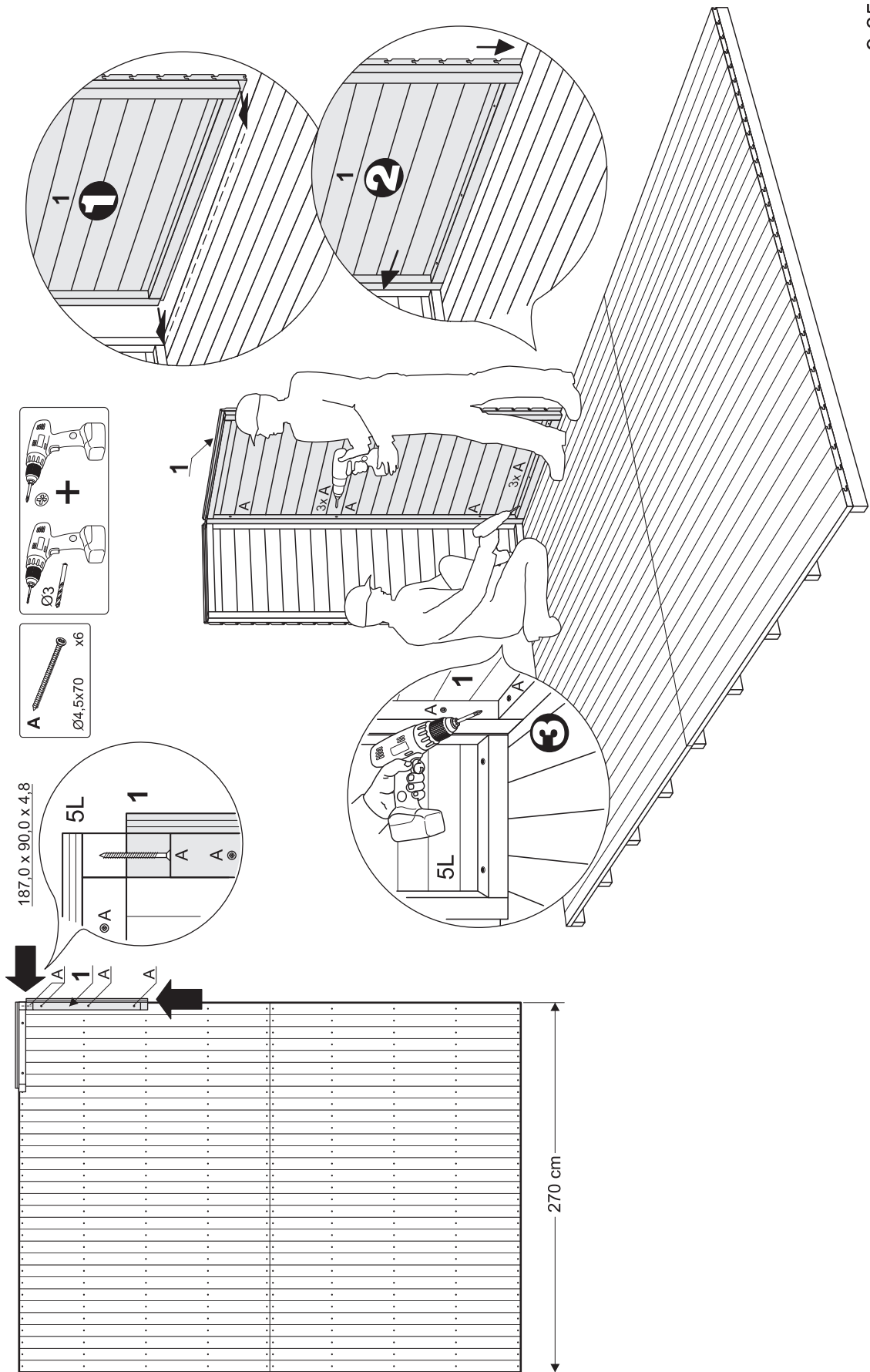

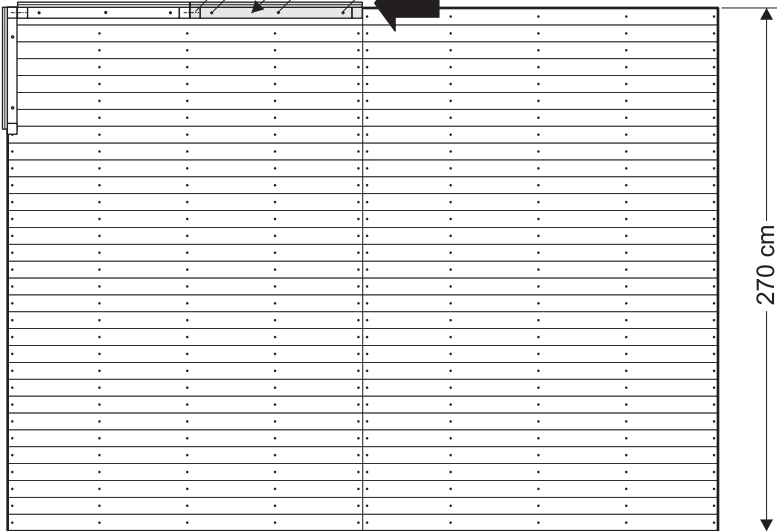

A
Ø4.5x70
x6

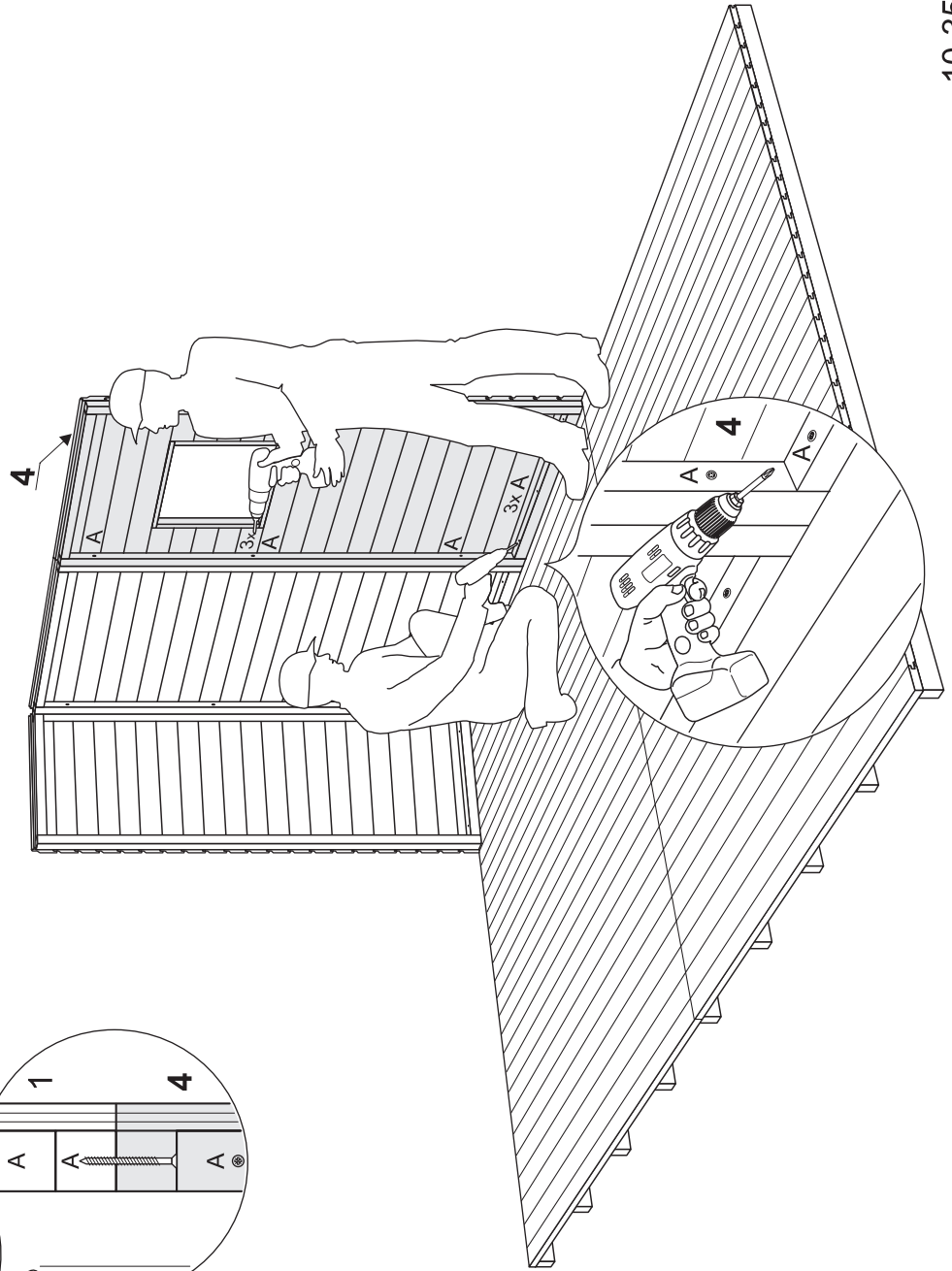

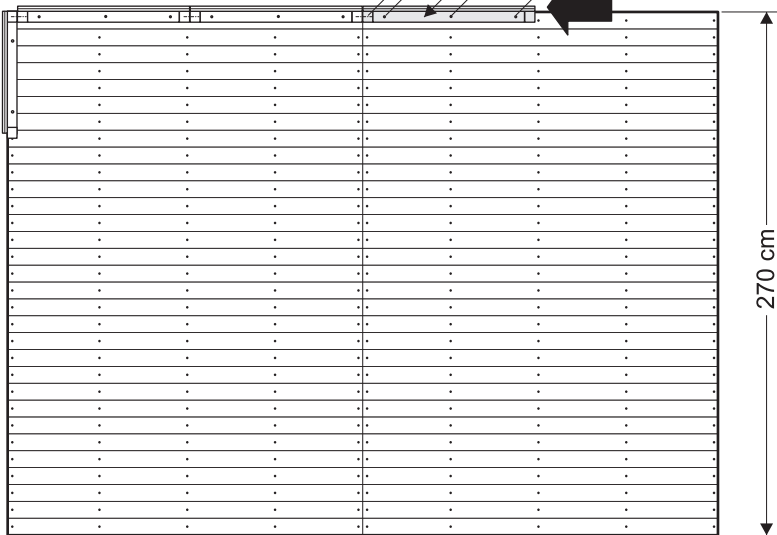

A
Ø4.5x70
x6

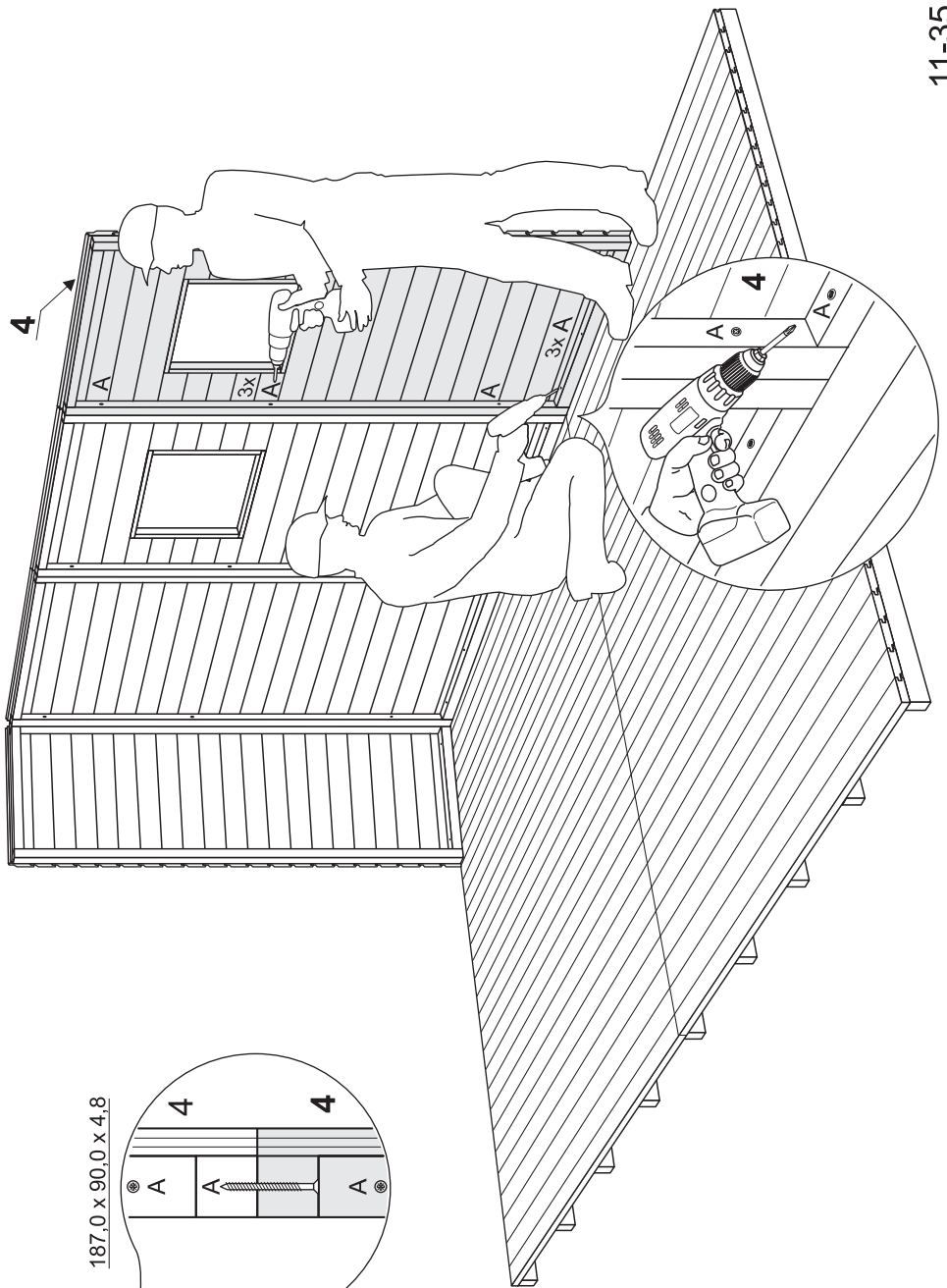
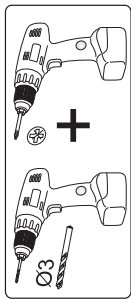

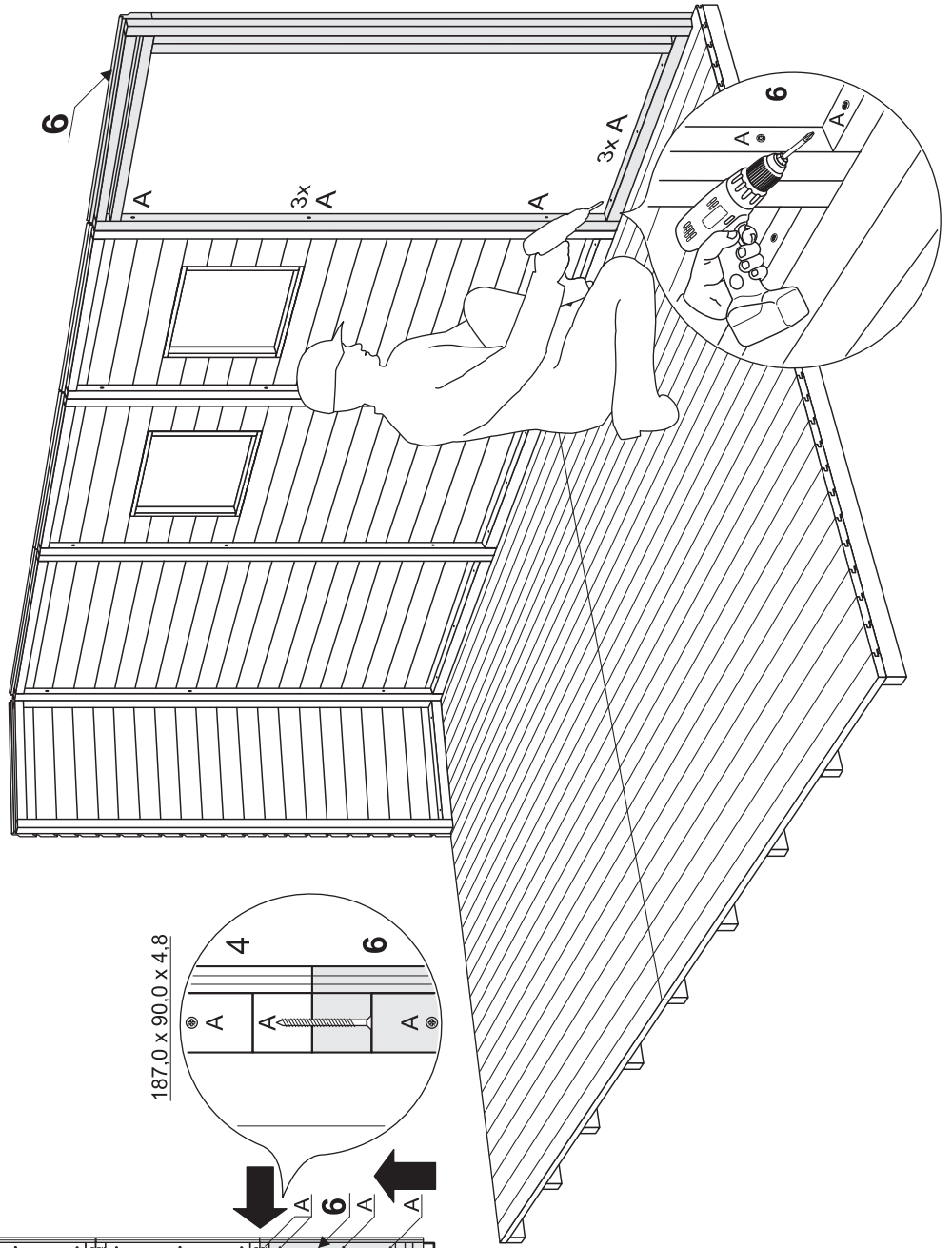
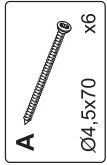
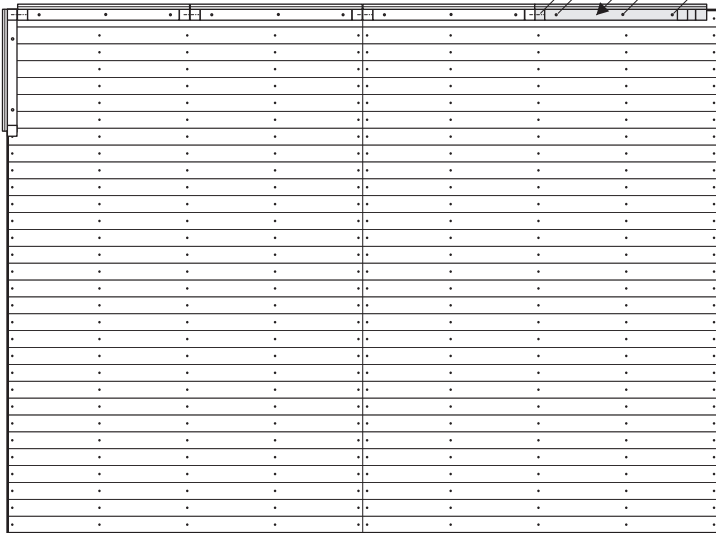

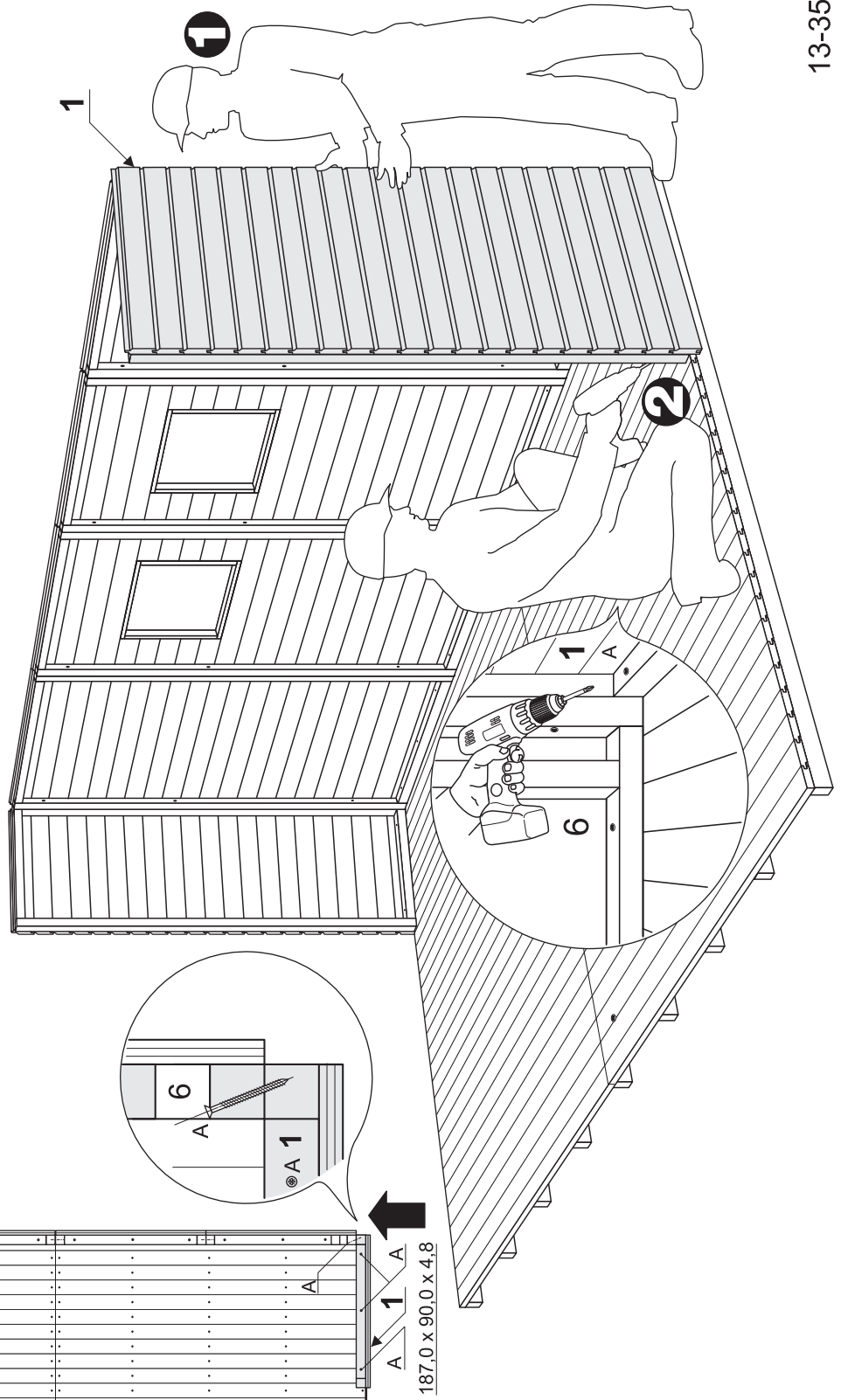
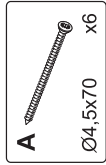
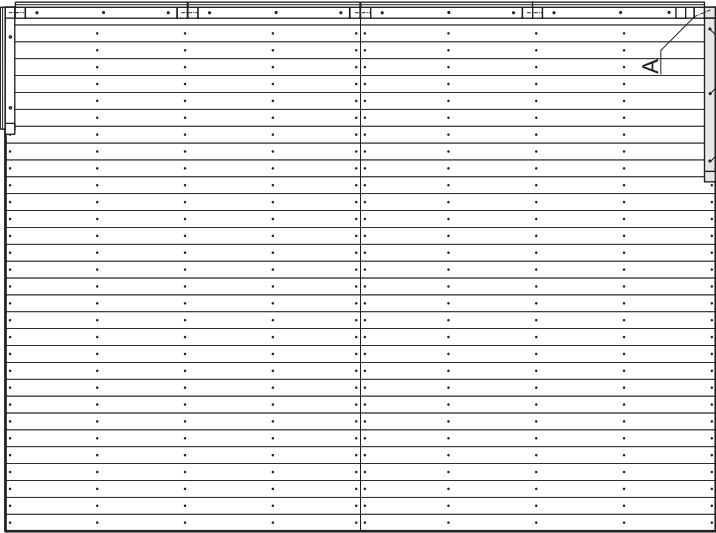

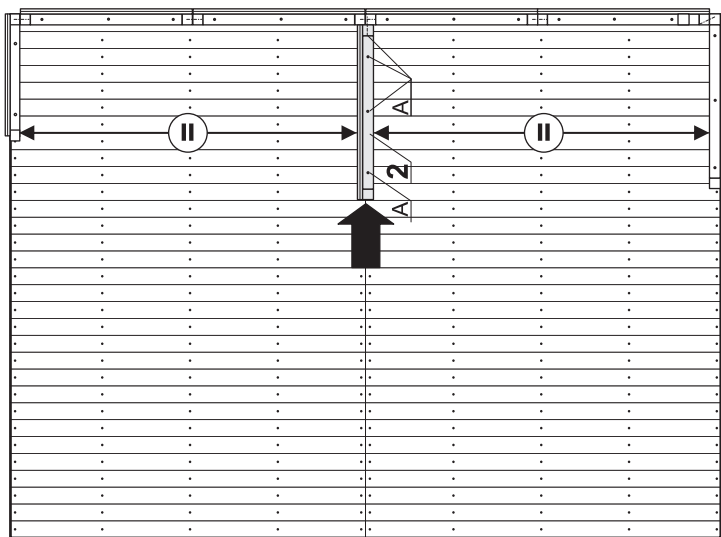

184,5 x 90,0 x 4,8

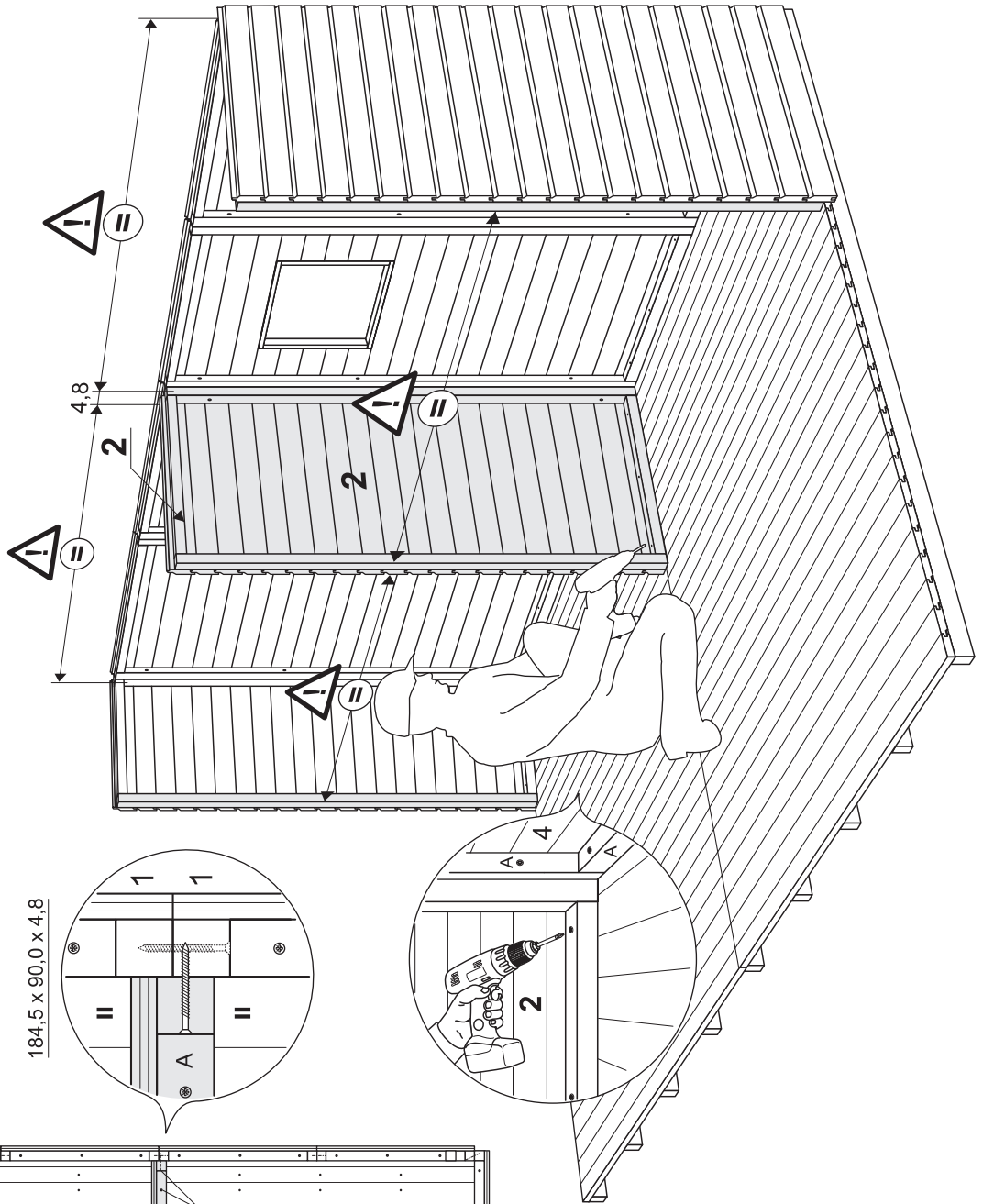
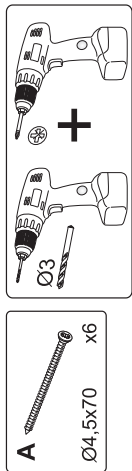
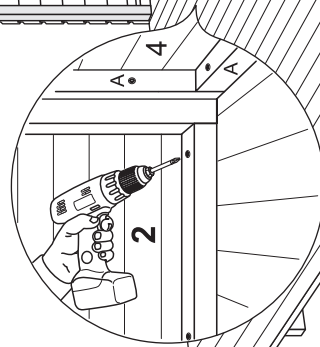
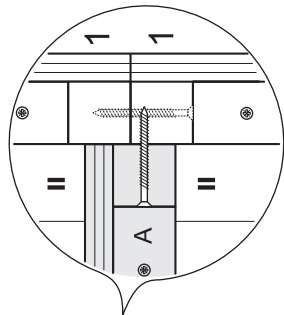

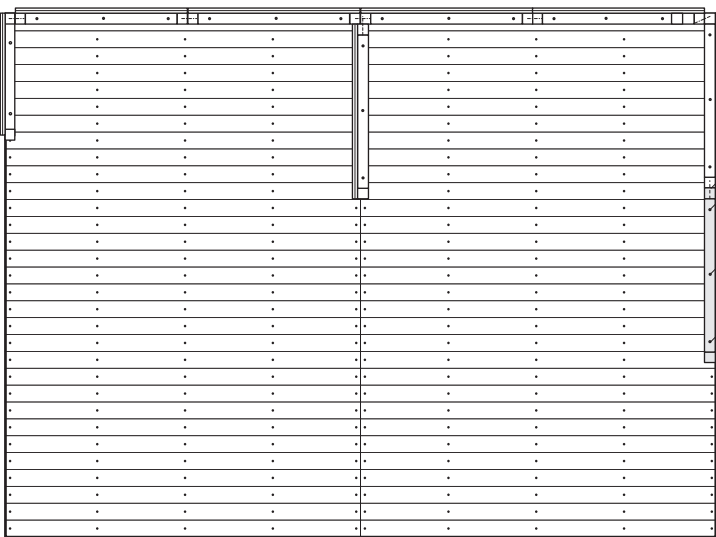

187,0 x 90,0 x 4,8

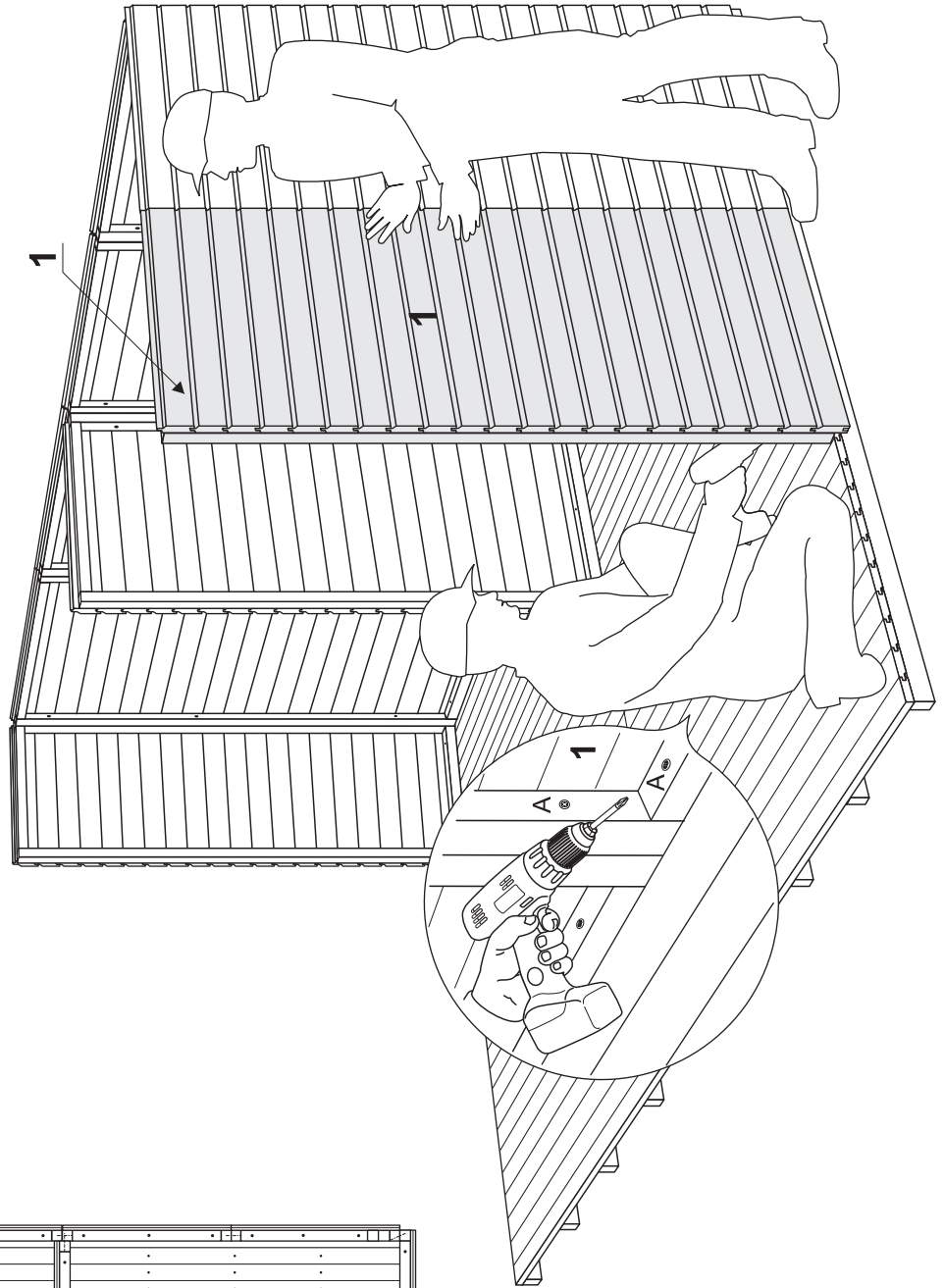
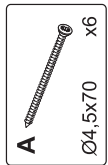
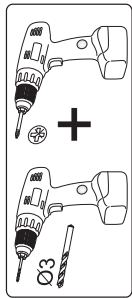

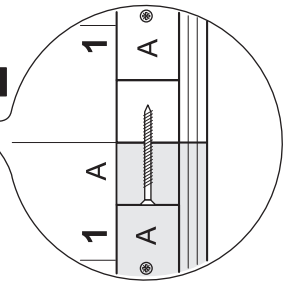
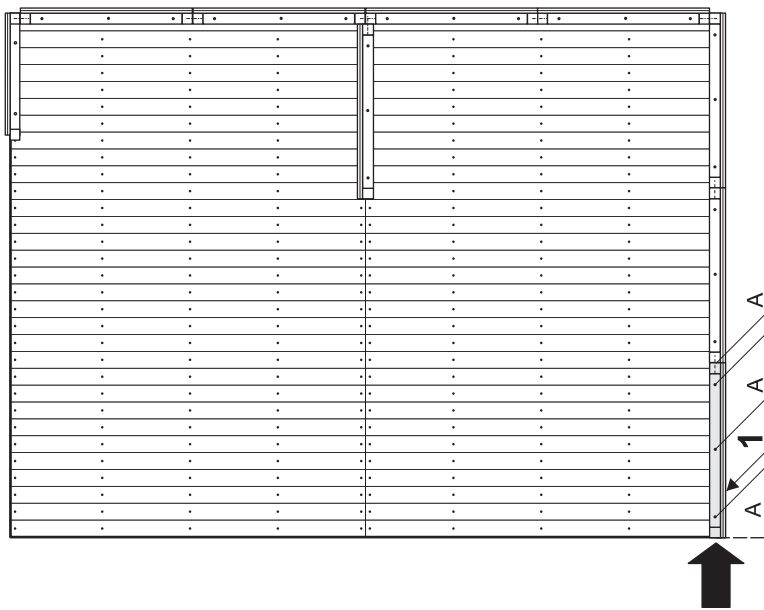

187.0 x 90.0 x 4.8

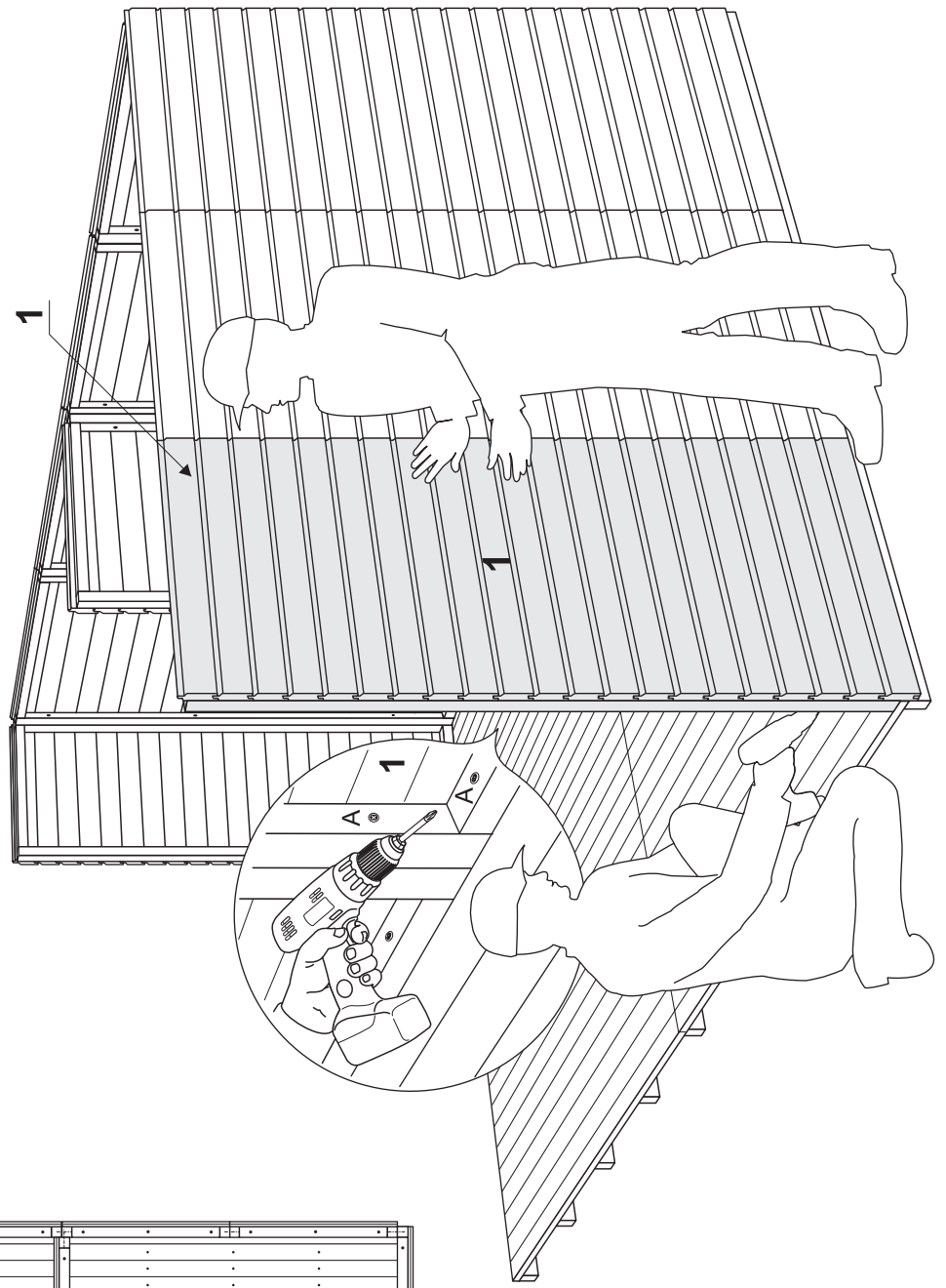
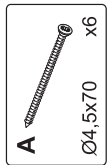
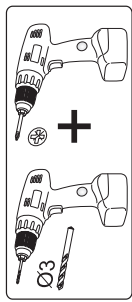

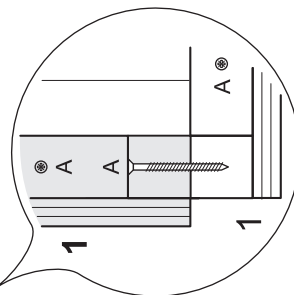
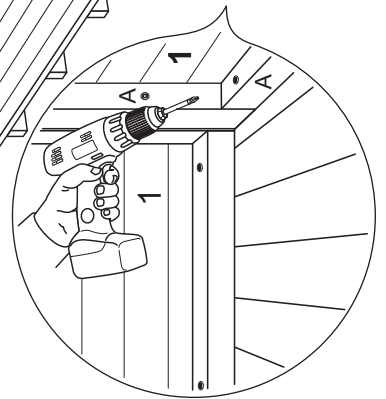
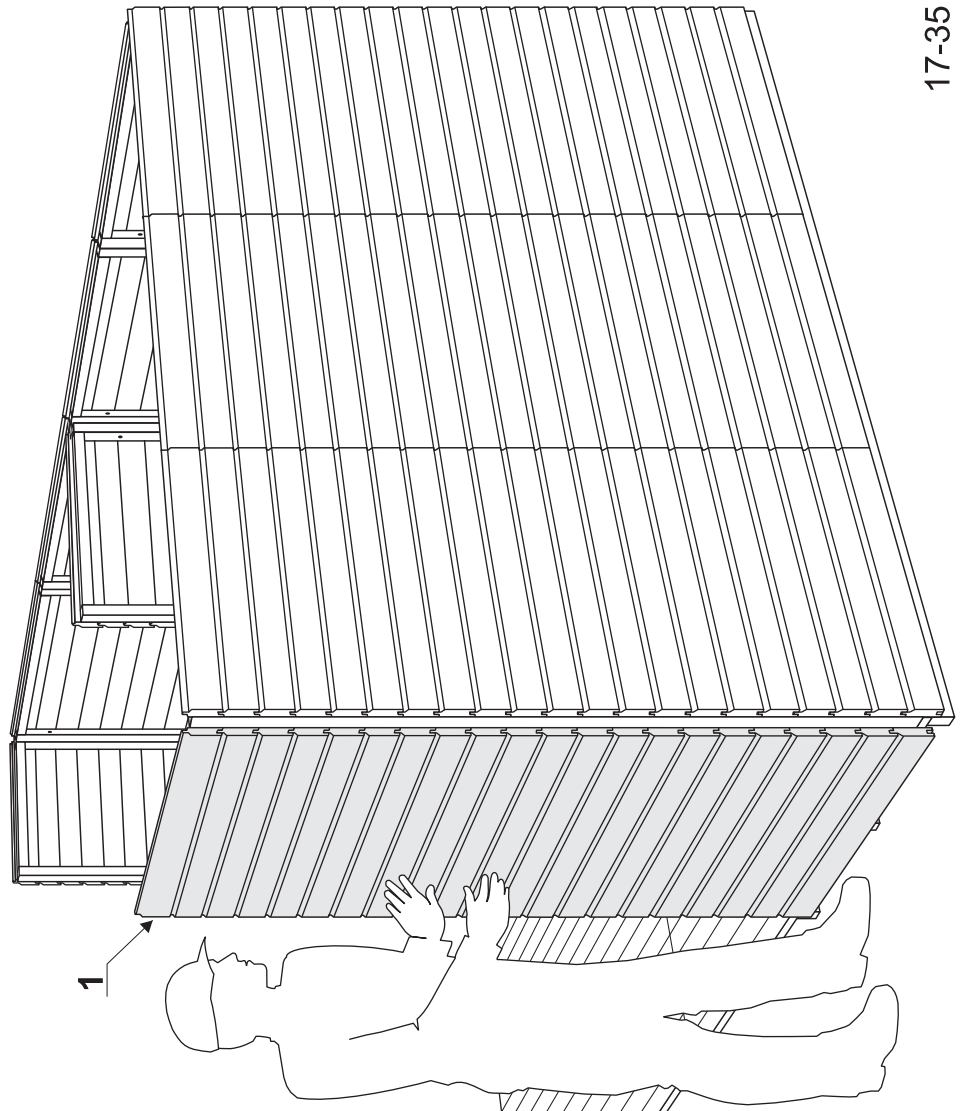
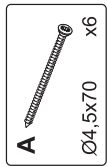
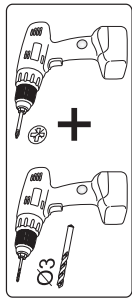
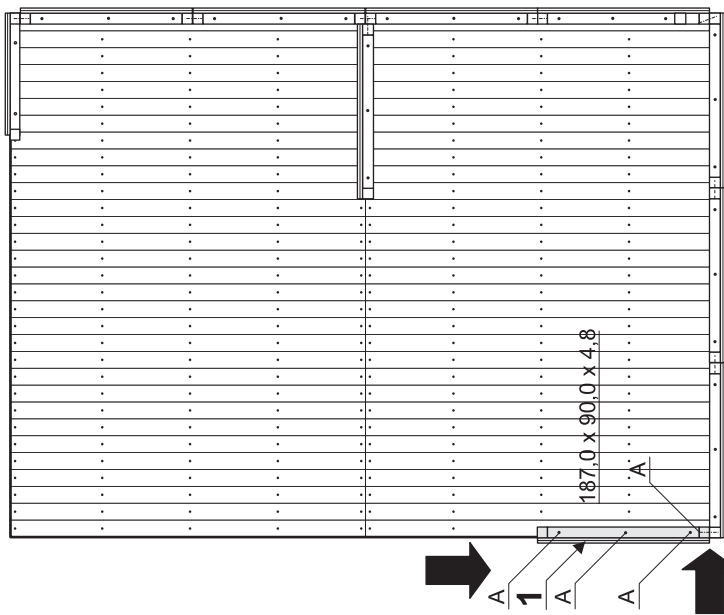

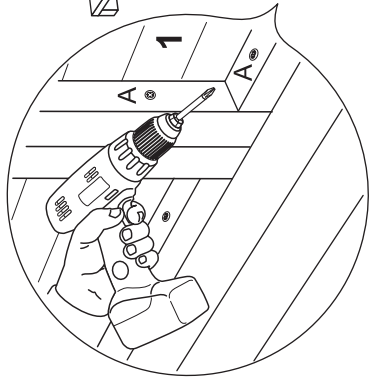
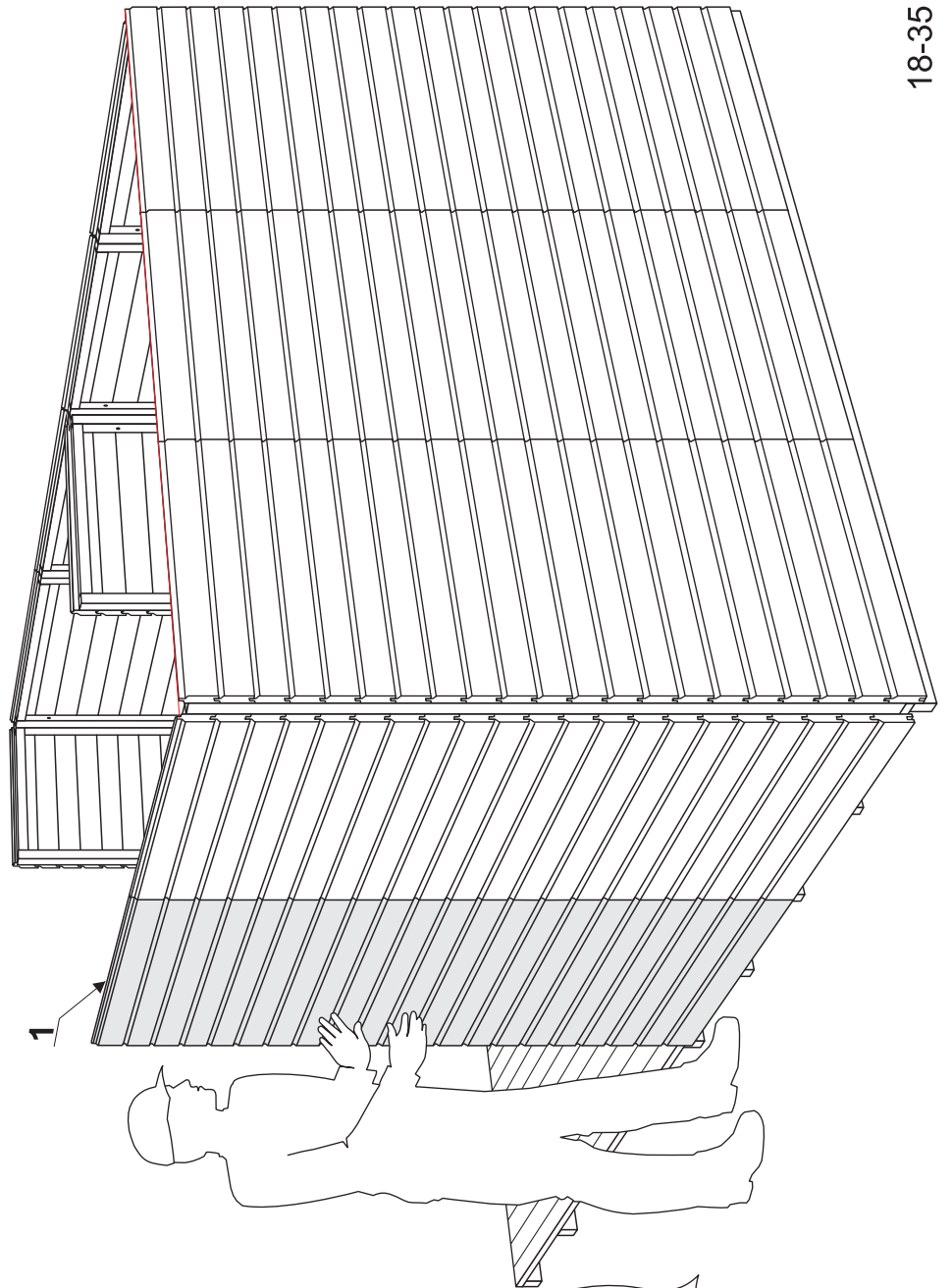
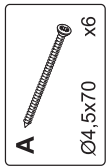
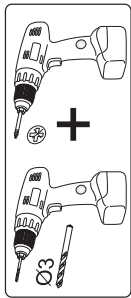
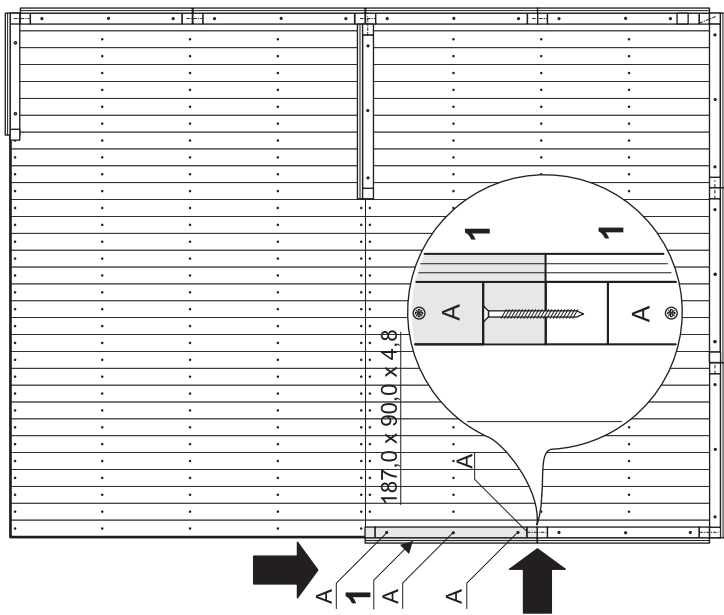

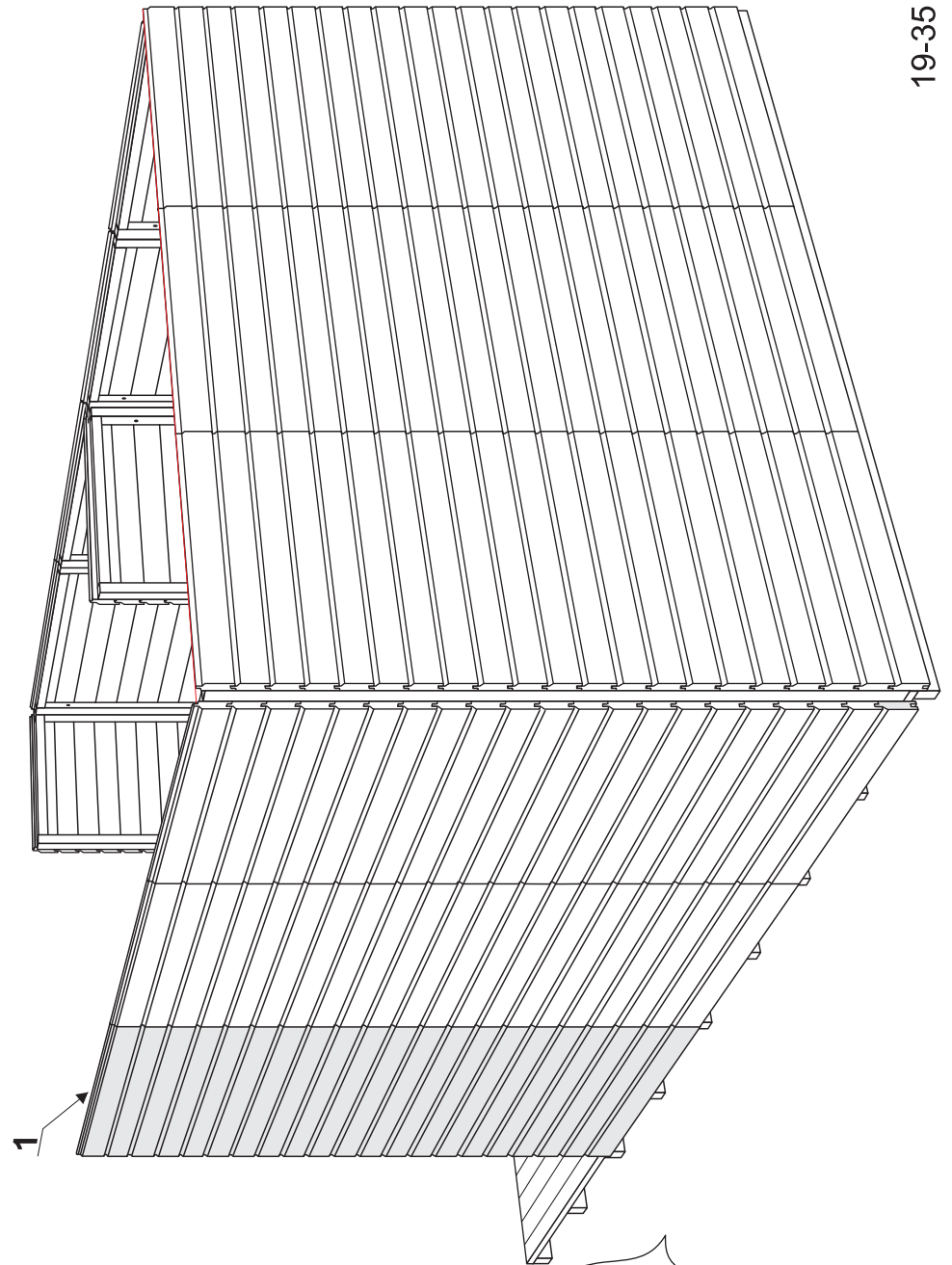
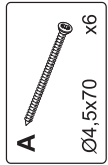
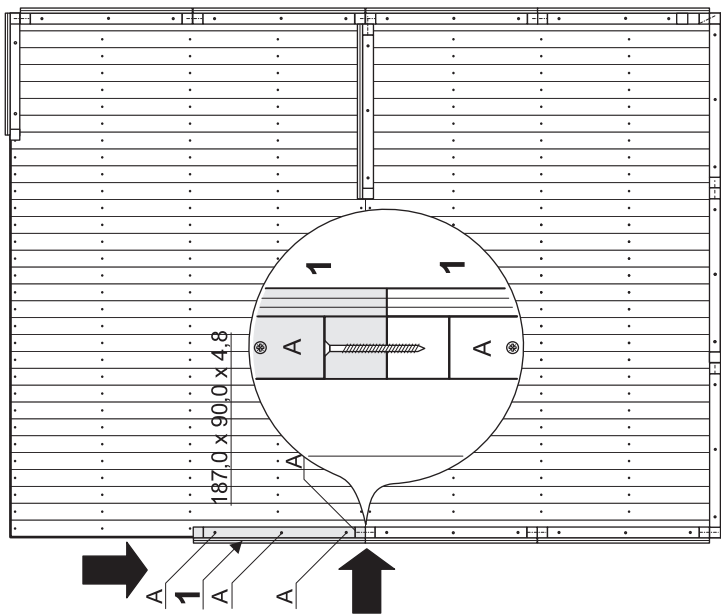

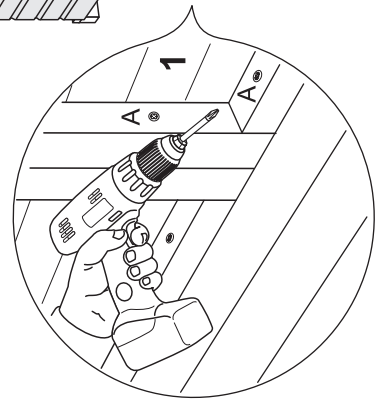
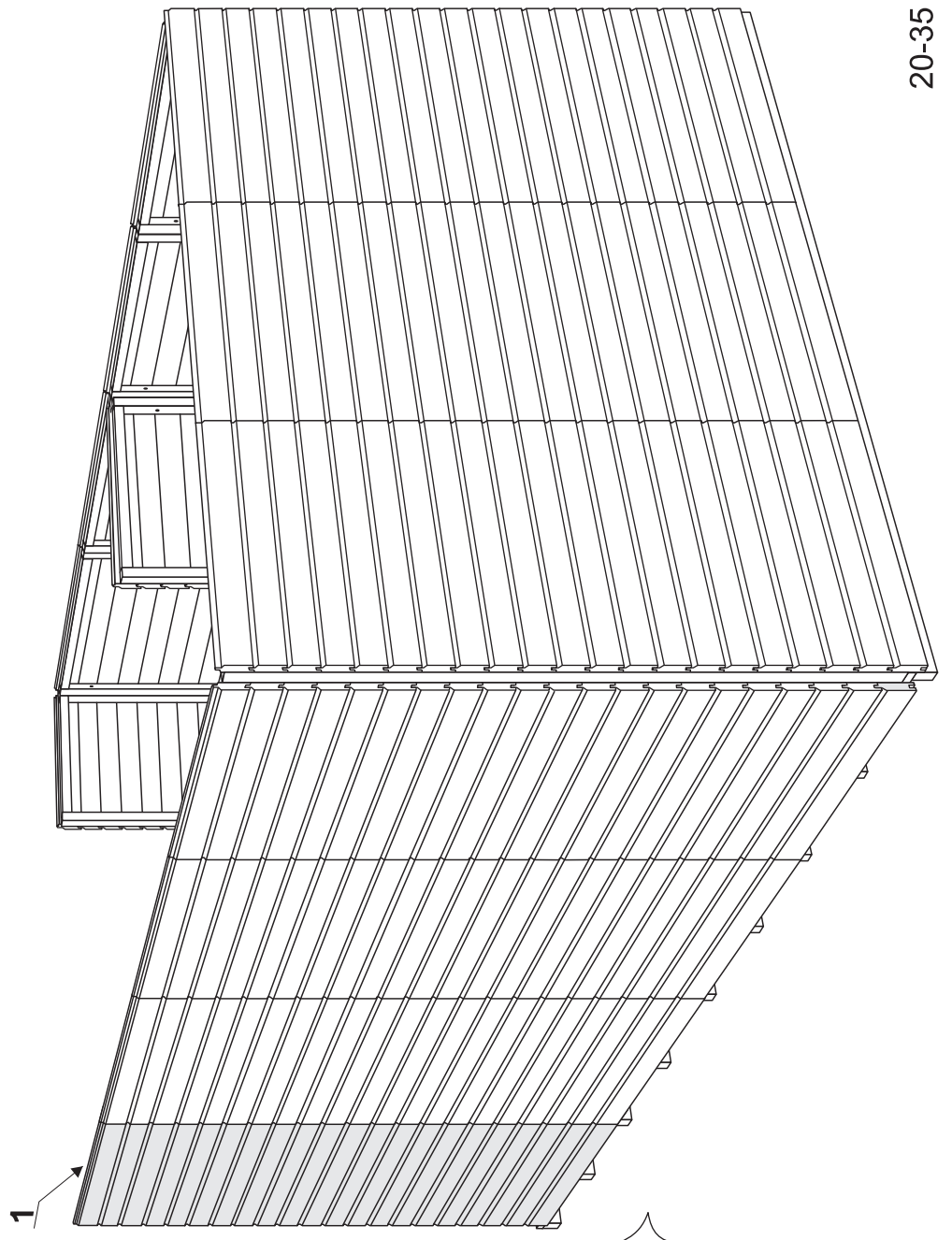
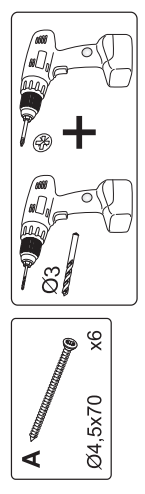
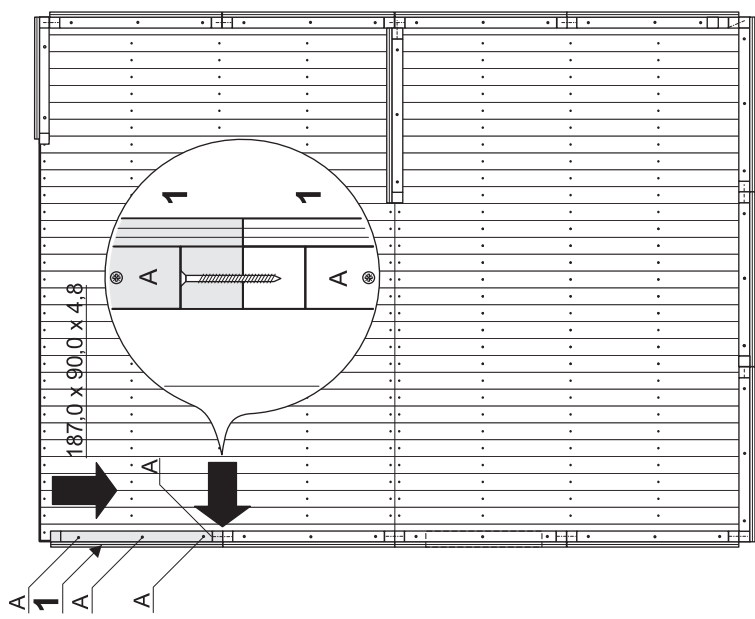

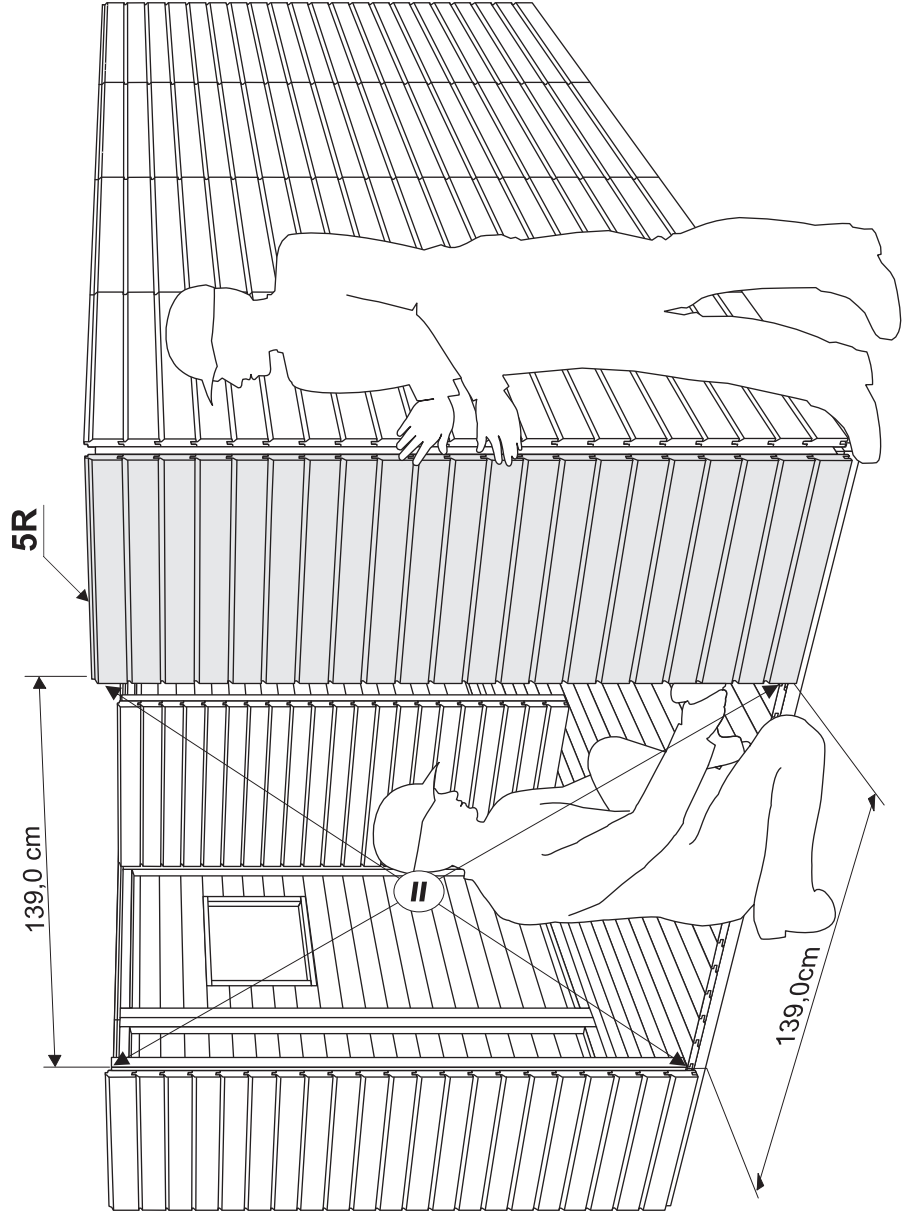
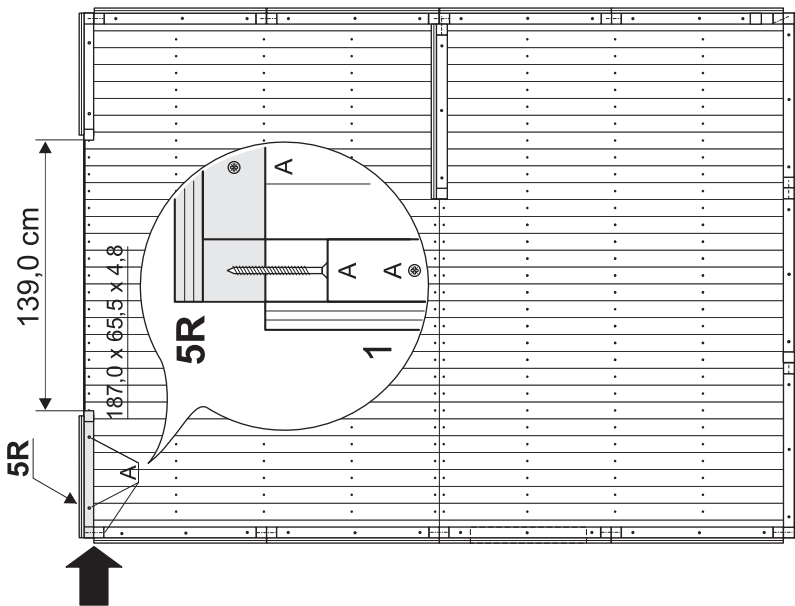
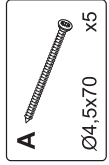
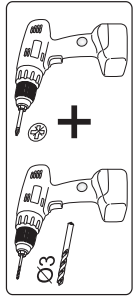

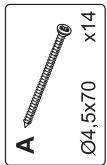
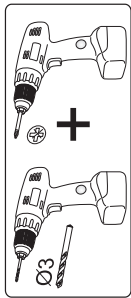
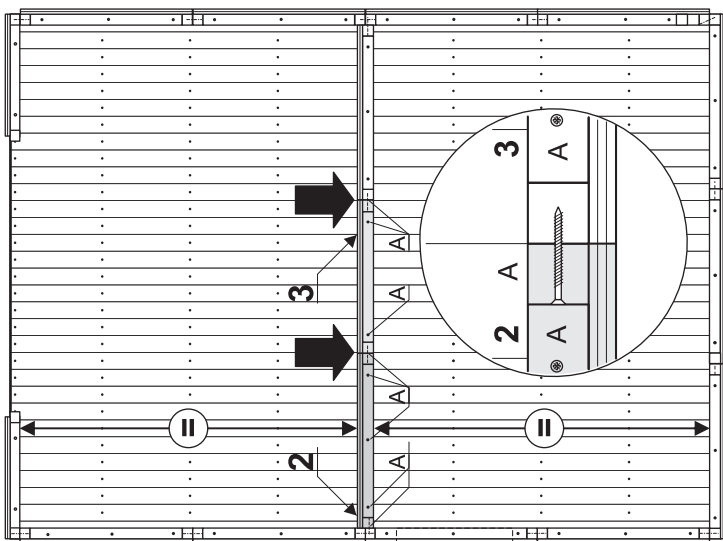

- 2** 184,5 x 90,0 x 4,8
- 3** 184,5 x 83,6 x 4,8

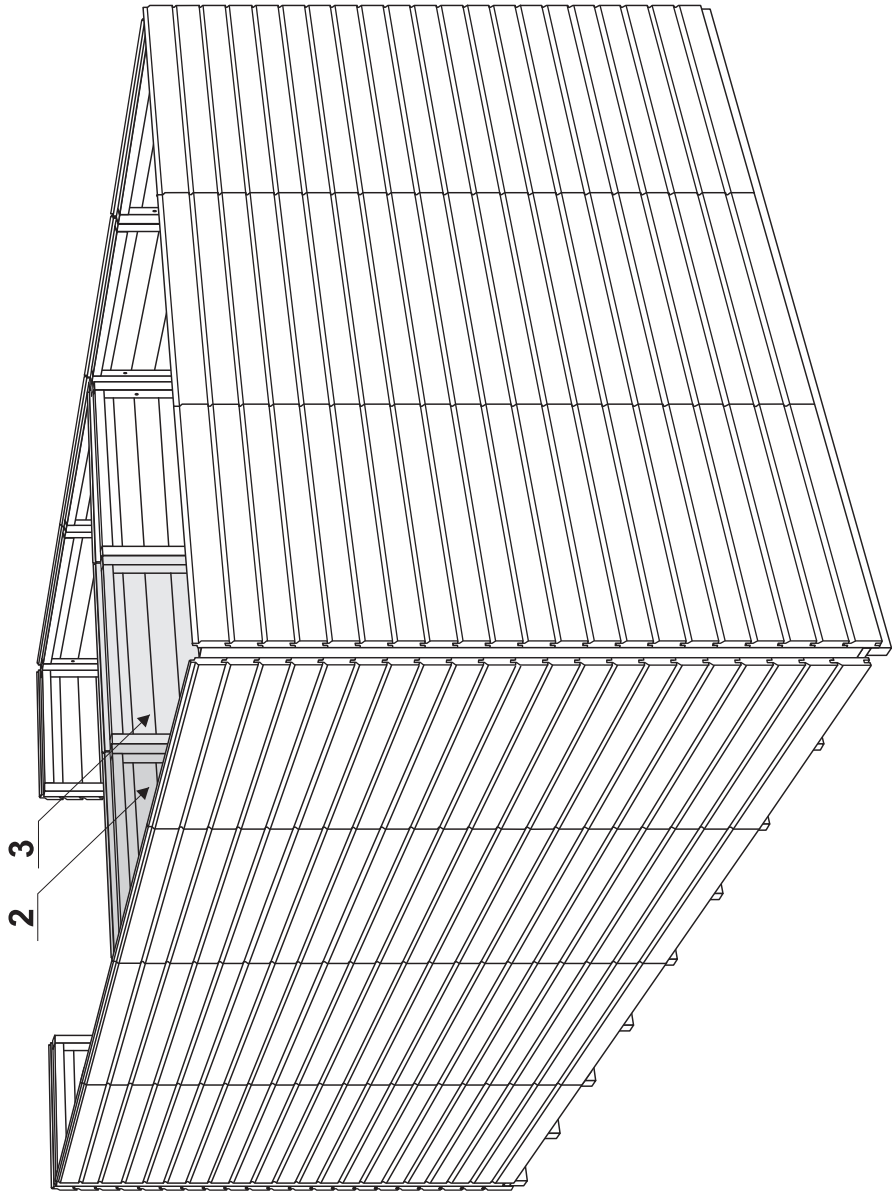

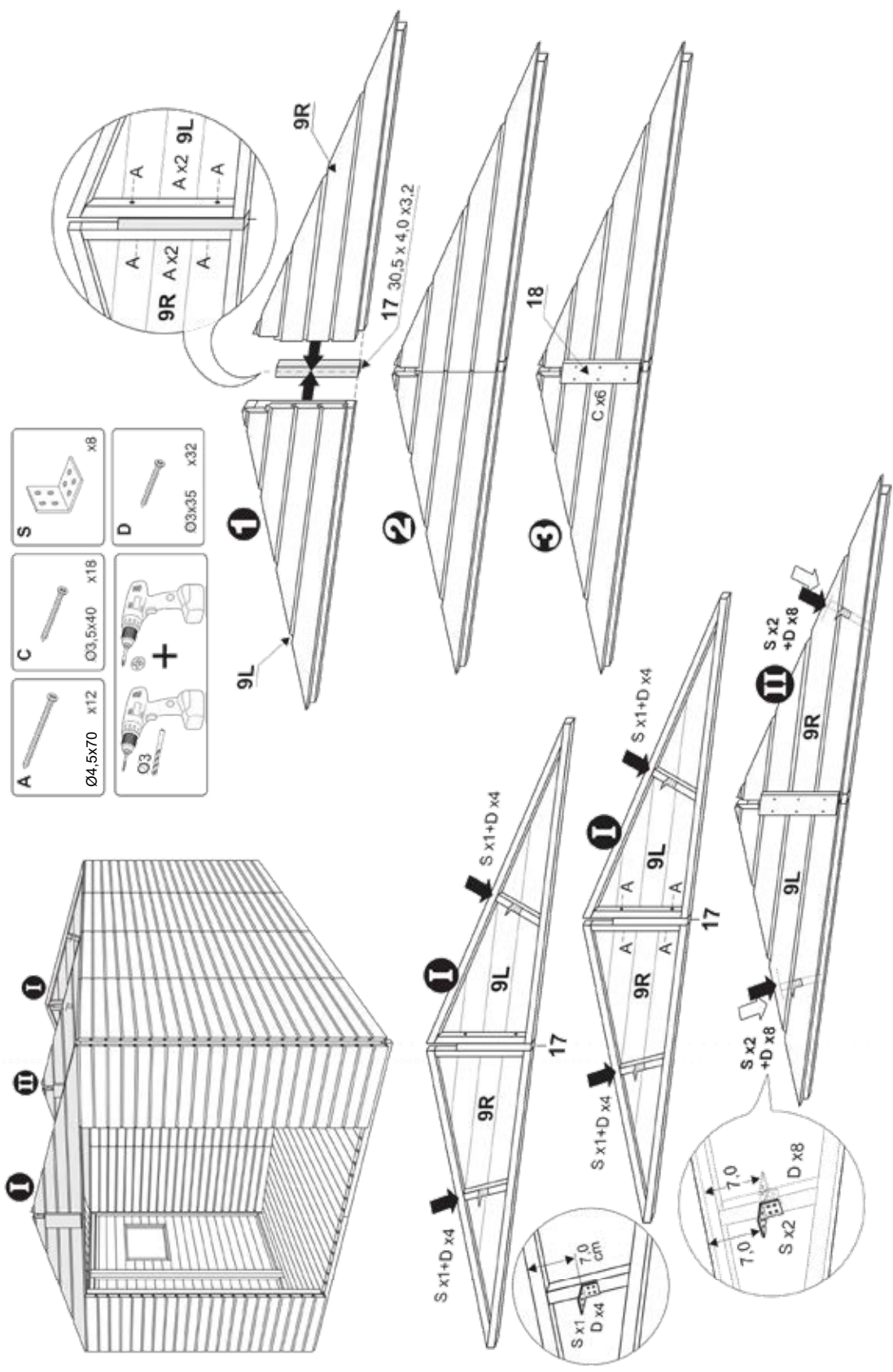

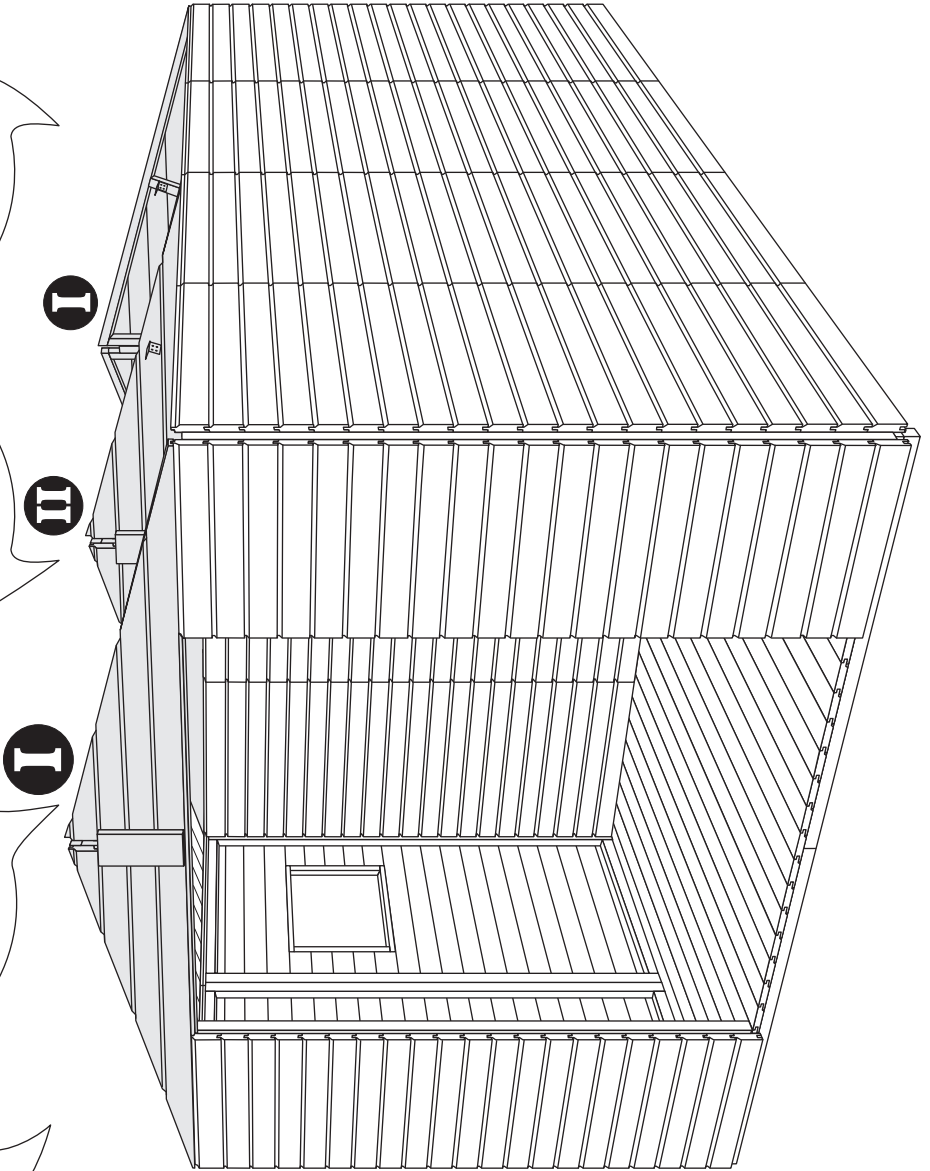
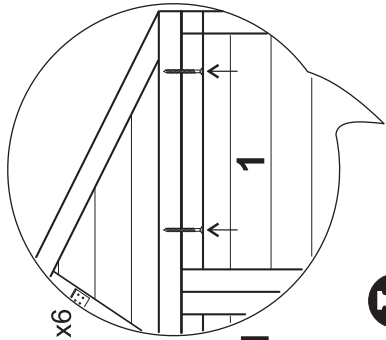
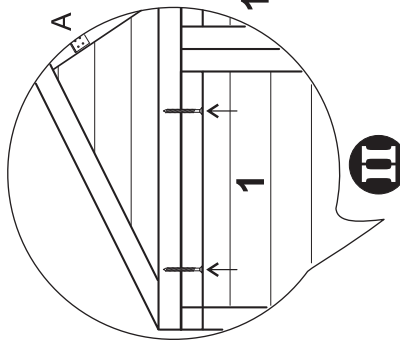
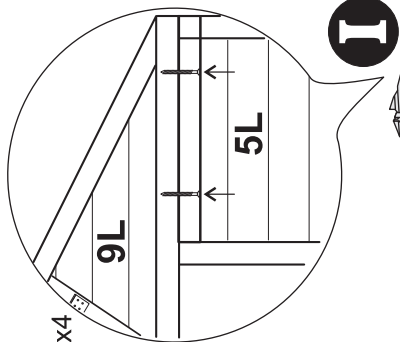
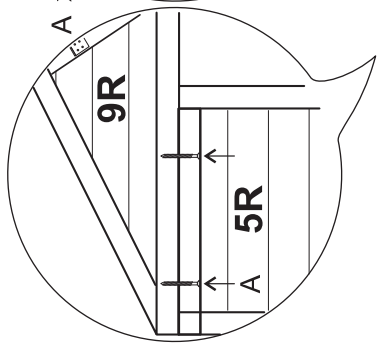

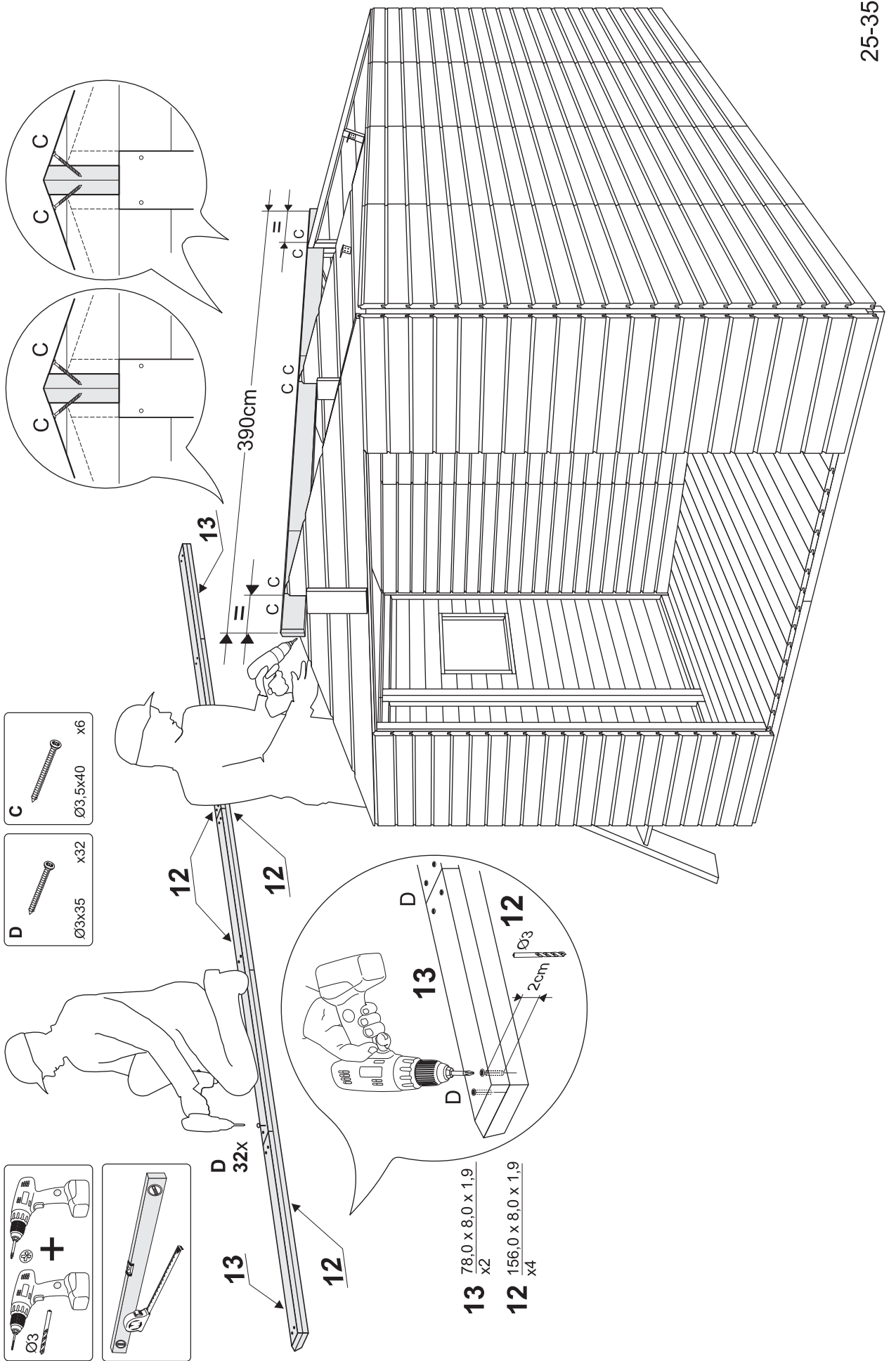
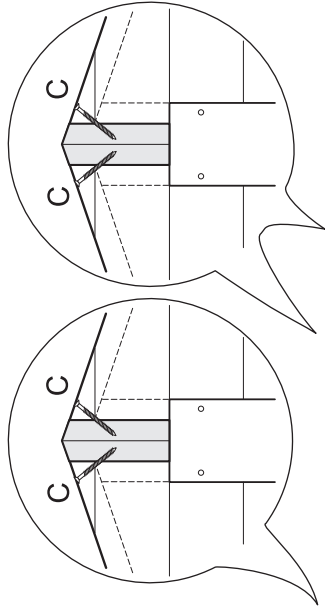
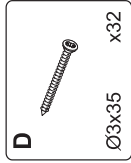
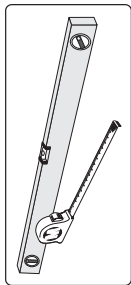
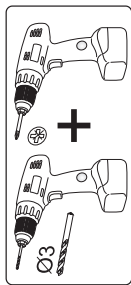

13 $\frac{78,0 \times 8,0 \times 1,9}{x2}$

12 $\frac{156,0 \times 8,0 \times 1,9}{x4}$

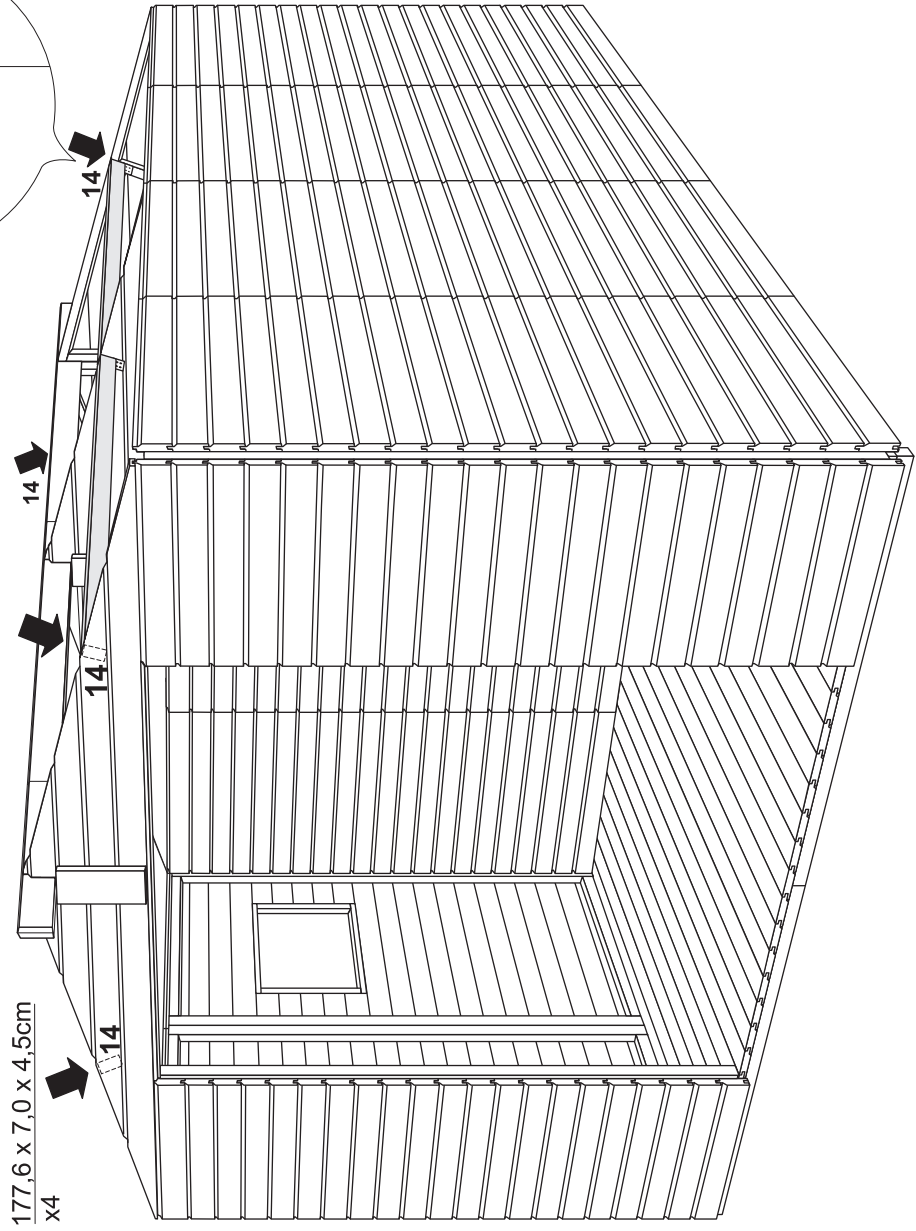
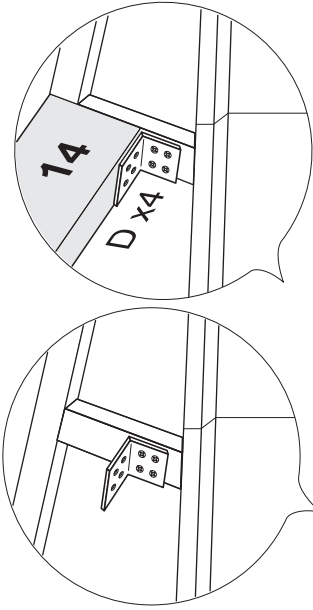
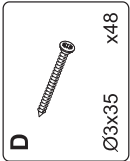
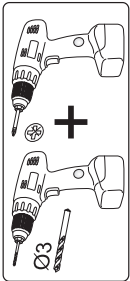
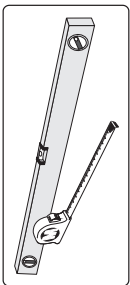

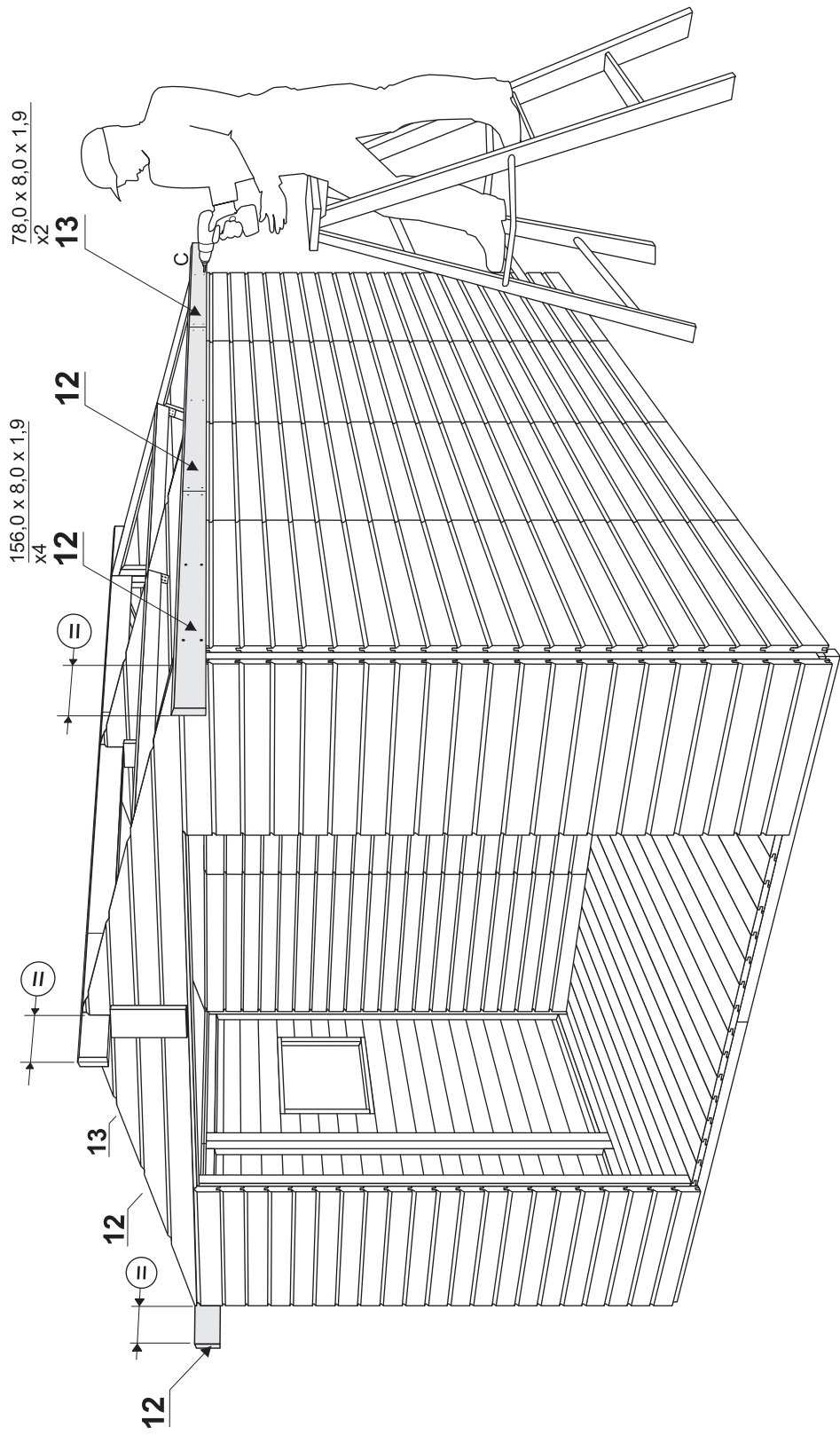
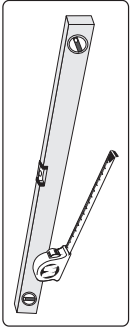

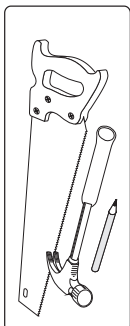

H
Ø2.5x50 x264

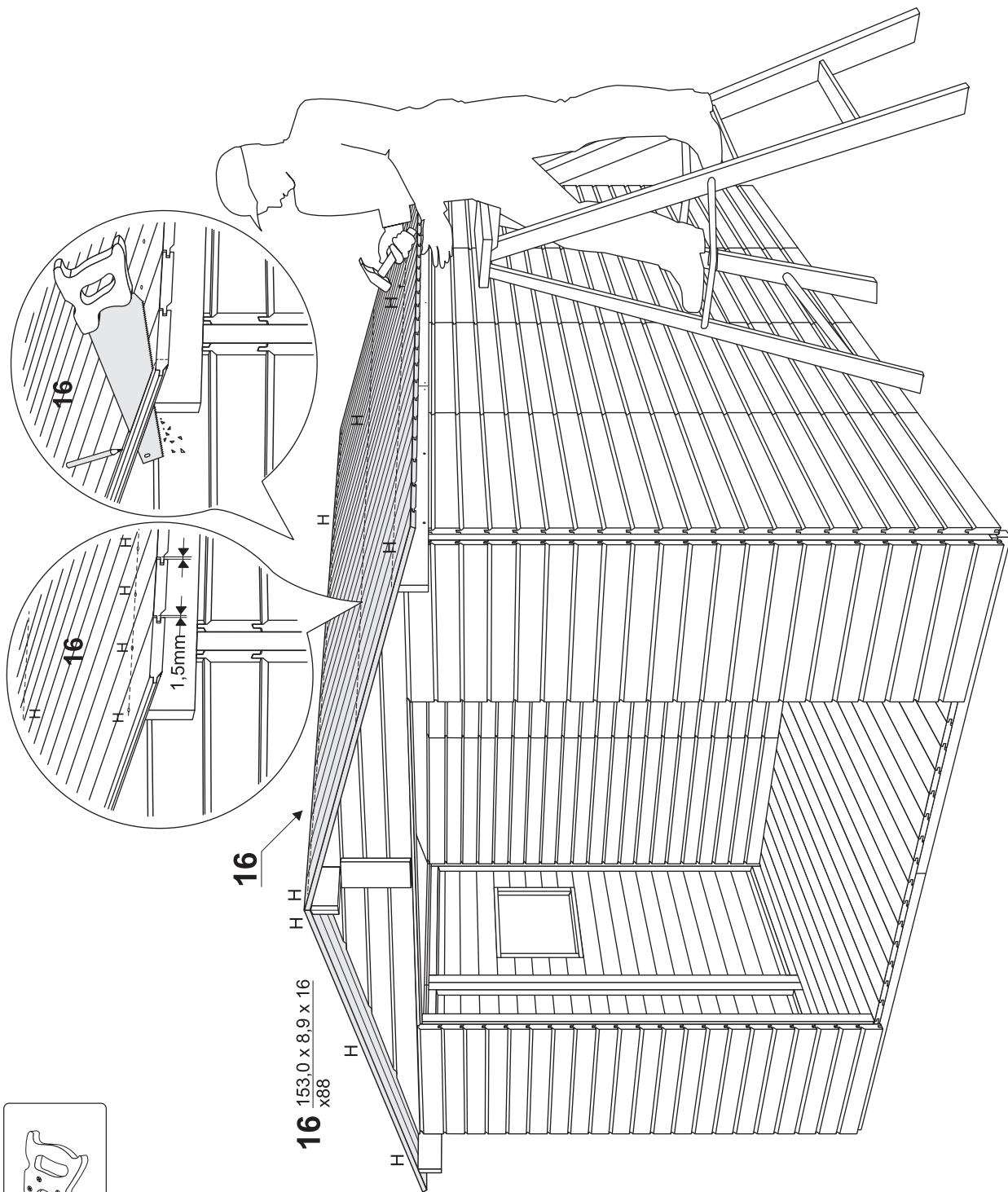
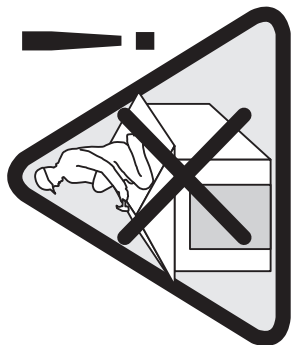

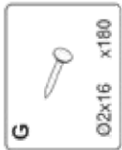

(Not included)
OPTIONAL!!!

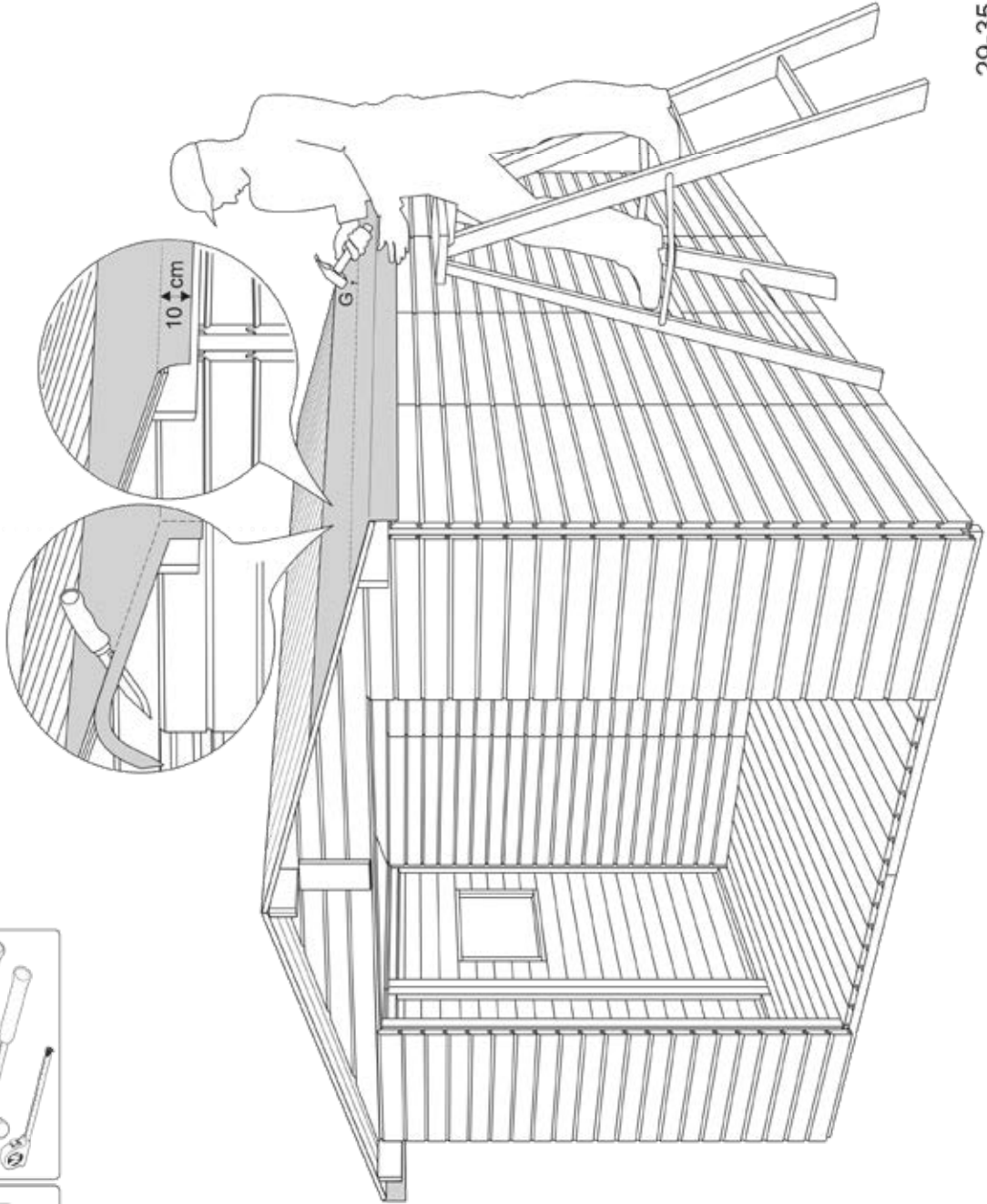
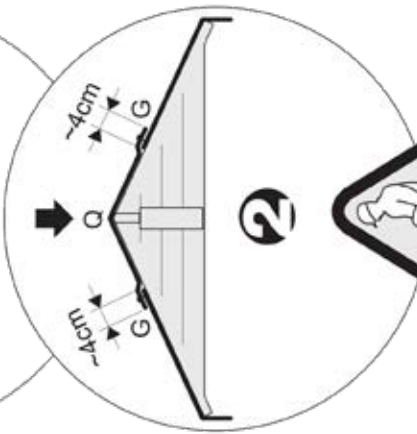
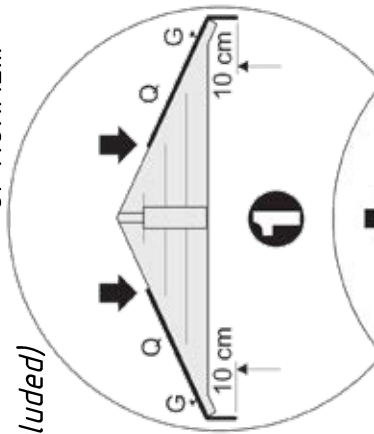

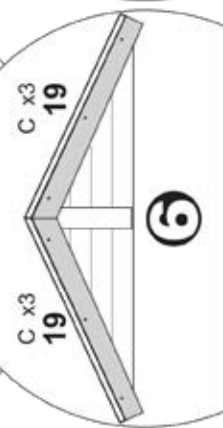
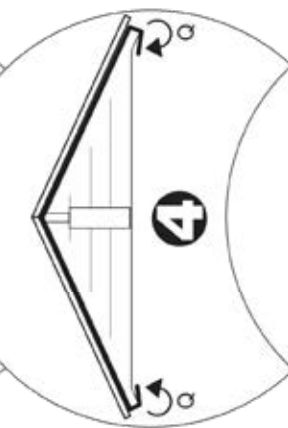
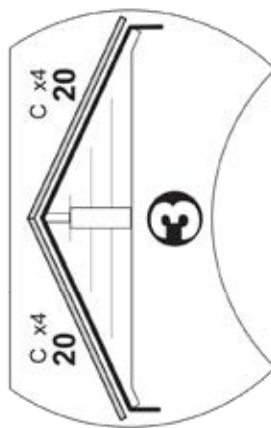
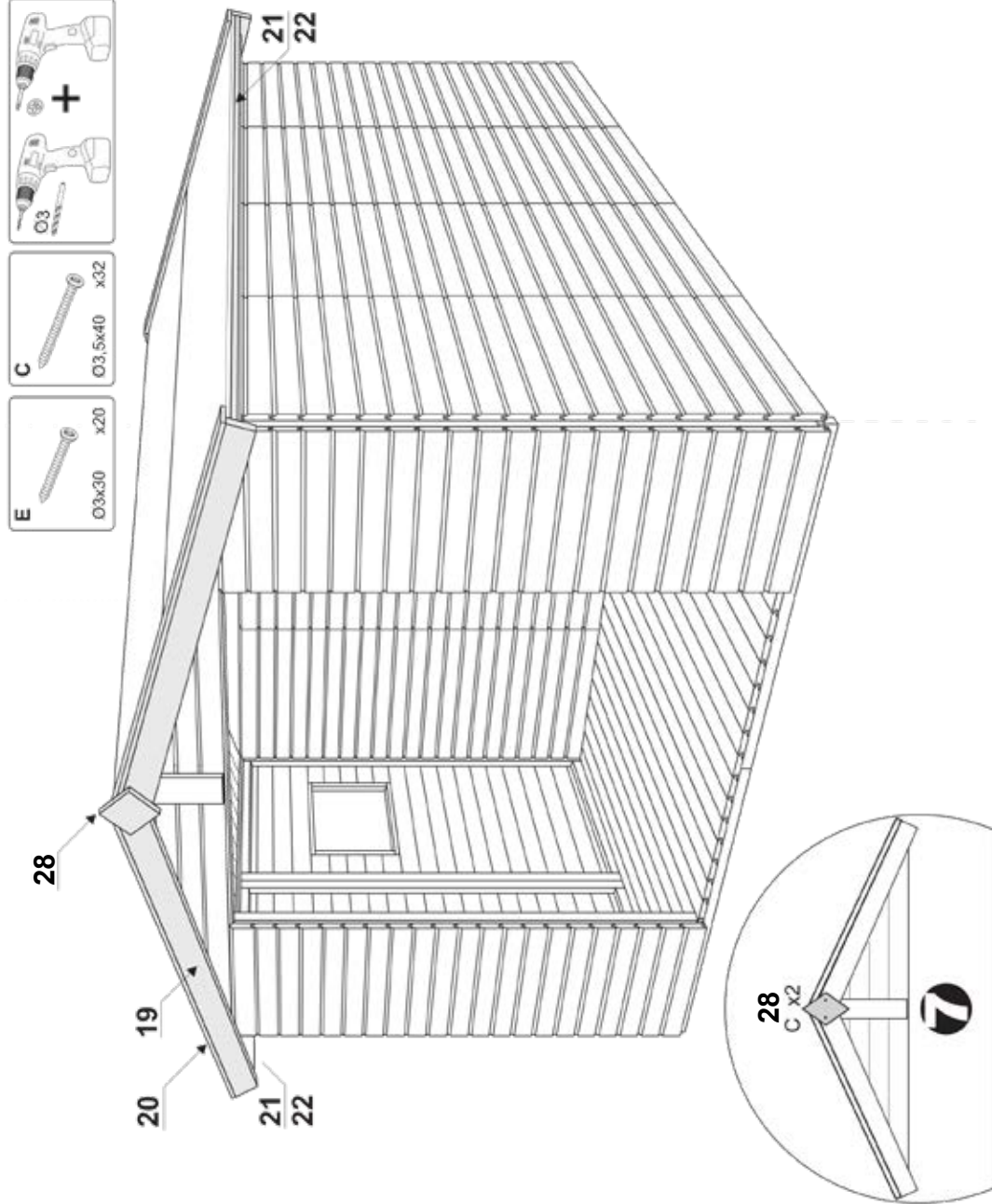
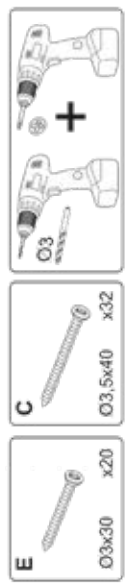

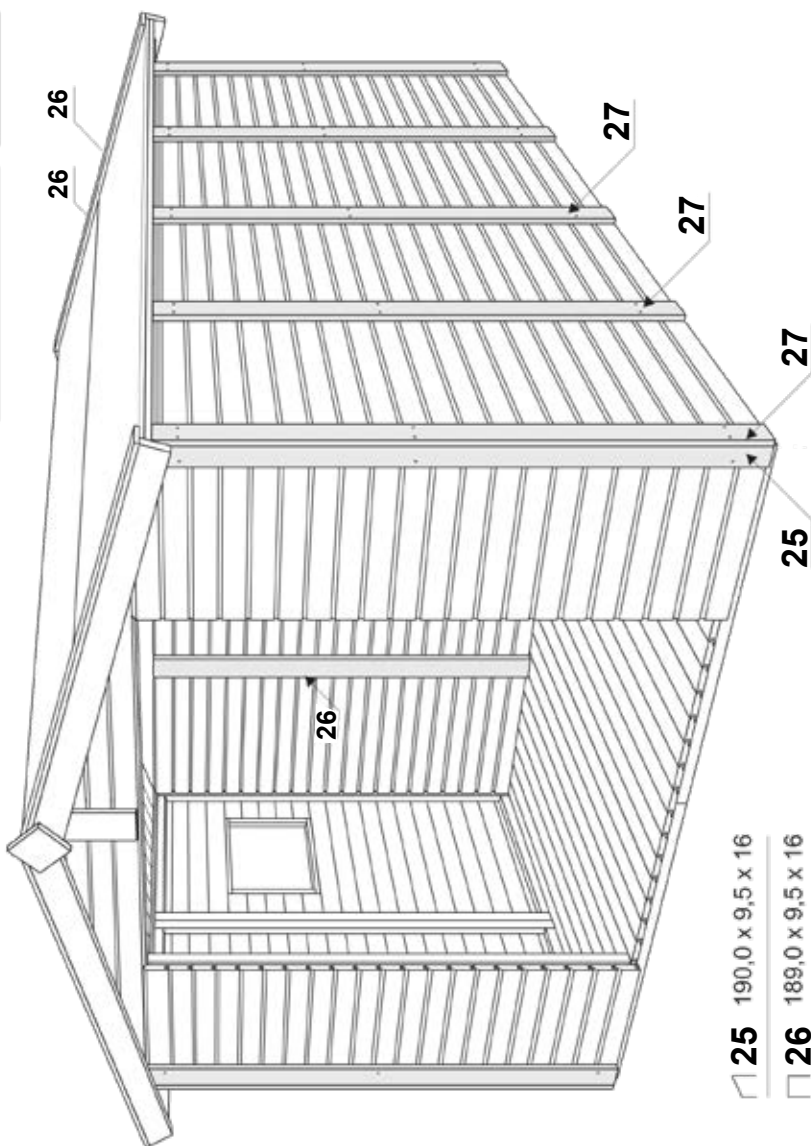
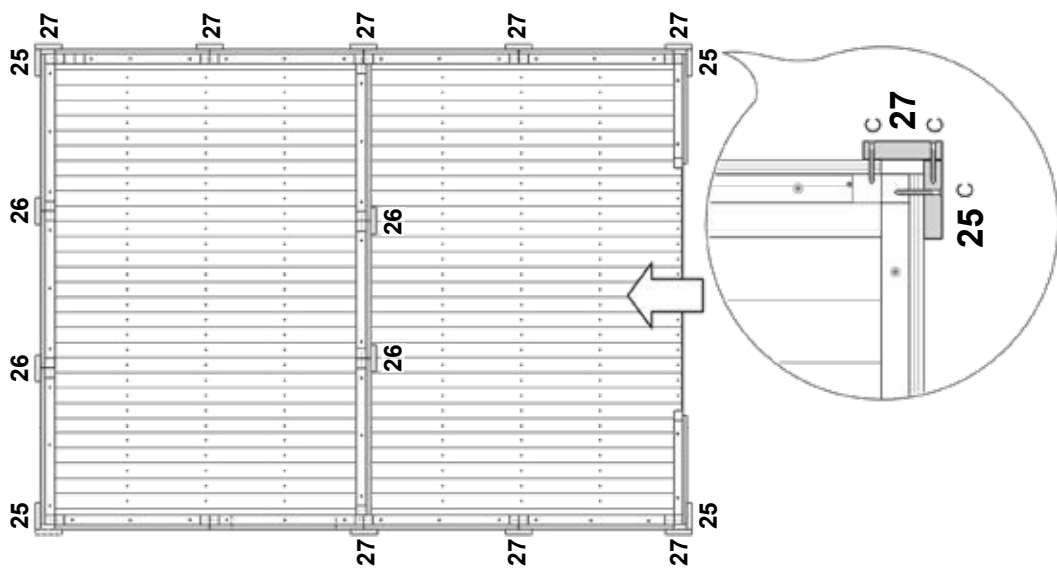

- ▮ 25 190,0 x 9,5 x 16
- ▮ 26 189,0 x 9,5 x 16
- ▮ 27 179,0 x 9,5 x 16

