

Assembly, installation and maintenance manual

Montage-, Aufbau- und Wartungsanleitung • Assemblage, manuel de montage et d'entretien • Montaje, instalación y mantenimiento • Manuale di montaggio, installazione e manutenzione • Monterings- og vedlikeholdsmanual • Monterings-, installations- och underhållsmanual • Kokoamis-, asennus- ja huolto-ohje • Vejledning for montering og vedligehold • Handleiding voor montage, installatie en onderhoud • Manual de montagem, instalação e manutenção • Návod k montáži, instalaci a údržbě • Instrukcja montażu, instalacji i konserwacji • Surinkimo, montavimo ir priežiūros vadovas • Montāžas, uzstādīšanas un apkopes rokasgrāmata • Руководство по сборке и обслуживанию • Montaaži-, paigaldus- ja säilitamise juhend



Element house EL16-2419

<p>Factory inspection by • Werkskontrolle durch • Contrôle à partir de l'usine par • Inspector de fábrica • Collaudato da • Fabrikkontroll utført av • Fabriksbesiktigat av • Tehtaan tarkastaja • Fabriks Kontrol udført af • Fabriekscontrole door • Inspeção de fábrica, por: • Zkontrolováno ve výrobním závodě • Kontrola fabryczna do • Apžiūrą gamykloje atliko Rūpnīcas pārbaudi veicis • Заводской контроль • Tehase kontroll teostatud:</p> <p>.....</p>	<p>Date • Datum • Date • Fecha • Data • Dato • Datum • Päiväys • Dato • Datum • Data • Datum • Data • Datums • Data • Дата • Kuupäev:</p>
	<p>Pack number • Pack Nr. • Packet n° • Bulto N° • Pacco N. • Serienr • Produktionsnummer • Pakettinro • Pakke nr. • Pak nr. • Número de embalagem • Číslo balení • Numer opakowania • Pakuotės numeris • Iepakojuma numurs • Упаковочный номер • Pakinumber:</p>



www.palmako.ee/information-hub

English: Before installing and using the product, please read the instructions and warranty terms at www.palmako.ee/information-hub to guarantee proper installation and long-lasting performance.

Deutsch: Wichtig! Bitte vor Aufbau und Nutzung des Produkts unbedingt die detaillierte Montageanleitung sowie die Garantiebedingungen unter www.palmako.ee/information-hub lesen, um eine fachgerechte Montage und eine lange Funktionssicherheit zu gewährleisten.

Français: Avant d'installer et d'utiliser le produit, veuillez lire les instructions et les conditions de garantie sur www.palmako.ee/information-hub afin de garantir une installation correcte et la longévité du produit.

Español: Antes de instalar y utilizar el producto, lea las instrucciones y las condiciones de garantía en www.palmako.ee/information-hub para asegurar una instalación correcta y una larga vida útil del producto.

Italiano: Prima di installare e utilizzare il prodotto, leggere le istruzioni e le condizioni di garanzia su www.palmako.ee/information-hub per garantire una corretta installazione e prestazioni durature.

Norsk: Før montering og bruk av produktet, vennligst les monteringsanvisningene og garantivilkårene på www.palmako.ee/information-hub for å sikre korrekt montering og fremtidig holdbarhet.

Svenska: Innan du installerar och använder produkten, vänligen läs instruktionerna och garantivillkoren på www.palmako.ee/information-hub för att säkerställa korrekt installation och produktens långvariga hållbarhet

Suomi: Ennen tuotteen asentamista ja käyttämistä, lue ohjeet ja takuehdot osoitteessa www.palmako.ee/information-hub varmistaaksesi oikean asennuksen ja pitkäkestoisen toiminnan.

Русский: Перед установкой и использованием изделия ознакомьтесь с инструкцией и условиями гарантии на сайте www.palmako.ee/information-hub, чтобы гарантировать правильную установку и долговечность изделия.

Eesti: Enne toote paigaldamist ja kasutuselevõttu lugege palun juhiseid ja garantiitingimusi aadressil www.palmako.ee/information-hub, et tagada nõuetekohane paigaldus ja toote pikk eluiga.

Dansk (Oversat af AI): Læs venligst instruktionerne og garantibetingelserne på www.palmako.ee/information-hub, før du installerer og bruger produktet, for at garantere korrekt installation og langvarig ydeevne.

Dutch (Vertaald door AI): Lees vóór de installatie en het gebruik van het product de instructies en garantievoorwaarden op www.palmako.ee/information-hub om een correcte installatie en langdurige werking te garanderen









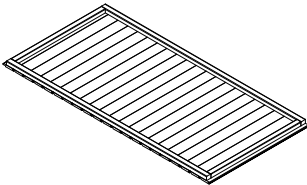
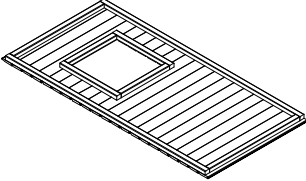
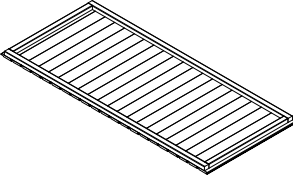
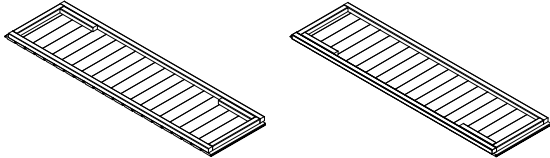

Português (Traduzido por IA): Antes de instalar e utilizar o produto, leia as instruções e os termos de garantia em www.palmako.ee/information-hub para garantir uma instalação adequada e um desempenho duradouro.

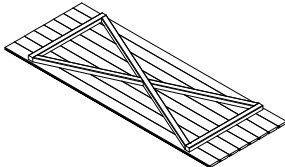

















Čeština (Přeloženo umělou inteligencí): Před instalací a použitím produktu si prosím přečtěte pokyny a záruční podmínky na www.palmako.ee/information-hub, abyste zaručili správnou instalaci a dlouhodobý výkon.

Polski (Przetłumaczone przez AI): Przed zainstalowaniem i użyciem produktu należy przeczytać instrukcję oraz warunki gwarancji dostępne na stronie www.palmako.ee/information-hub, co pozwoli zagwarantować prawidłową instalację i długotrwałą wydajność.

Latviešu (Mākslīgā intelekta tulkojums): Pirms produkta uzstādīšanas un lietošanas, lūdzu, izlasiet instrukcijas un garantijas noteikumus vietnē www.palmako.ee/information-hub, lai garantētu pareizu uzstādīšanu un ilgstošu darbību.

Lietuviškai (Išvertė DI): Prieš montuodami ir naudodami gaminį, perskaitykite instrukcijas ir garantijos sąlygas adresu www.palmako.ee/information-hub, kad užtikrintumėte tinkamą montavimą ir ilgalaikį veikimą.

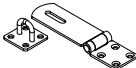
Pos	04.05.2026 SPECIFICATION-STÜCKLISTE-NOMENCLATURE-ELEMENTI-ESPECIFICACIÓN EL16-2419	1/2	Pcs	Profile (mm)	Length (mm)
1			3	1870x900x48	
2			1	1870x900x48	
3			3	1870x800x48	
4L 4R			1+1	1870x505x48	
5L 5R			2+2	1180x366x48	
8			2	1865x700x48	
6	 Detail- Detail- Detail- Dettaglio- Detalle		2	40x32	292
7	 Slat- Leiste- Bagueffe- Listello- Listón		2	95x16	275
9	 Rafter- Sparre- Chevron- Trave- Cabrio		4	80x19	1380
10	 Rafter- Sparre- Chevron- Trave- Cabrio		4	80x19	670
11	 Foundation- Fundament- Fondation- Fondazione- Vigas de cimentación		10	40x32	1200
12	 Foundation- Fundament- Fondation- Fondazione- Vigas de cimentación		5	40x32	430
13	Floor board- Fussbodenbrett- Madrier du plancher - Tavola pavimento- Tabla de suelo 		27+1 21+1	89x16 114x16	1864
14	Roof board- Dachbrett- Madrier du toit- Tavola tetto- Tabla de tejado 		46 36	89x16 114x16	1350

Pos	04.05.2026 SPECIFICATION-STÜCKLISTE-NOMENCLATURE-ELEMENTI-ESPECIFICACIÓN EL16-2419	2/2	Pcs	Profile (mm)	Length (mm)
15	Side slat- Randleiste- Baguette en bordure- Listón de borde- Listello bordo 		4	95x16	1900
16	Side slat- Randleiste- Baguette en bordure- Listón de borde- Listello bordo 		2	95x16	1890
17	Side slat- Randleiste- Baguette en bordure- Listón de borde- Listello bordo 		6	95x16	1790
18	Eave edging- Dachrandbrett- Madrier en bordure du toit- Tavola bordo tetto- Tabla de valadizo 		4	45x16	1025
19	Eave edging- Dachrandbrett- Madrier en bordure du toit- Tavola bordo tetto- Tabla de valadizo 		4	45x16	1370
20	Facia board- Giebelblende- Écran frontal- Schermo frontone- Tabla de facia 		4	95x16	1370
21	Slat- Leiste- Baguette- Listello- Listón 		2	45x16	910
22	Diamond- Deckbrett- Madrier- Tavola di copertura- Rombo- 16x95 		2	16x95	300
Fim	-Fixing kit- Befestigungsset- Moyens de fixation- Materiale di fissaggio- Kit de fijación		1		
A	Screw- Schraube- Vis- Vite- Tornillo- 5x70mm TX 		64		
B	Screw- Schraube- Vis- Vite- Tornillo- 4.5x60mm 		20		
C	Screw- Schraube- Vis- Vite- Tornillo- 3.5x40mm 		148		
D	Screw- Schraube- Vis- Vite- Tornillo- 3.5x35mm 		20		
E	Screw- Schraube- Vis- Vite- Tornillo- 3x30mm 		18		
F	Screw- Schraube- Vis- Vite- Tornillo- 3x16mm 		24		
H	Nail- Nagel- Clou- Chiodo- Clavo- 2.5x50mm 		230		
I	Nut- Schraubenmutter- Écrou- Dado- Tuerca- M6mm 		8		
I	Bolt -Schloss-schraube -Boulon- Bullone- Perno- M6x60mm PUP0 		8		
L	Hasp- Haspe- Porte-cadenas- Portaluchetto- Amella para candado- 100x35x2.5Zn 		1		
O	Hook- Haken- Crochet- Ganzio- Pestillo 80x30 		2		
R	Door hinge- Türbänder- Charniere de porte- Cerniere porta- Bisagra de puerta- QHT200Zn 		4		

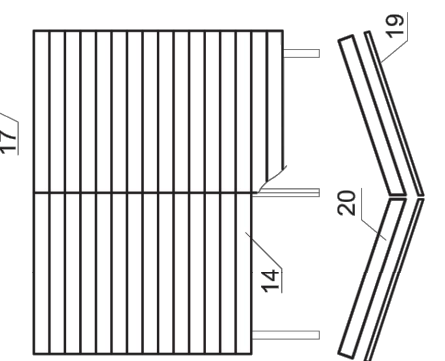
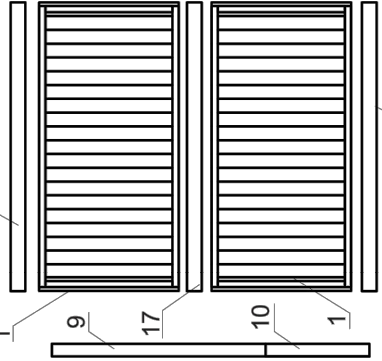
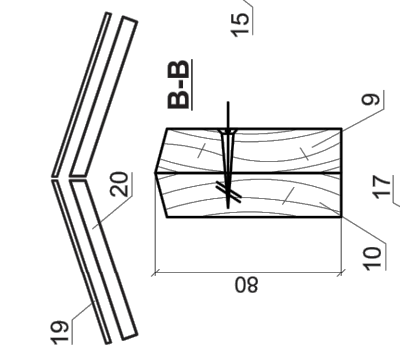
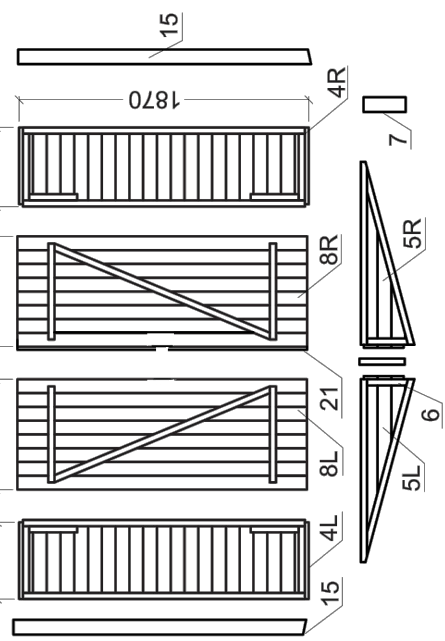
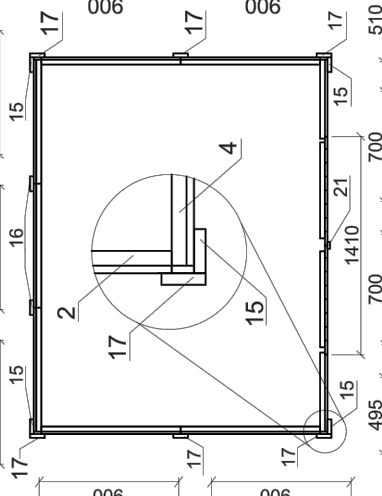
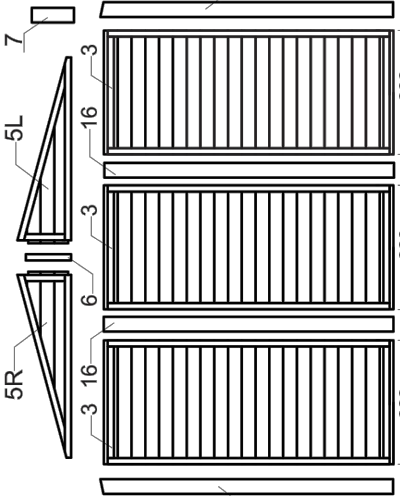
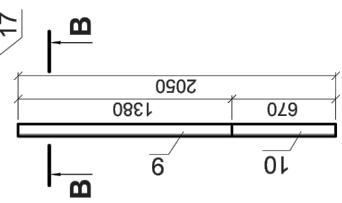
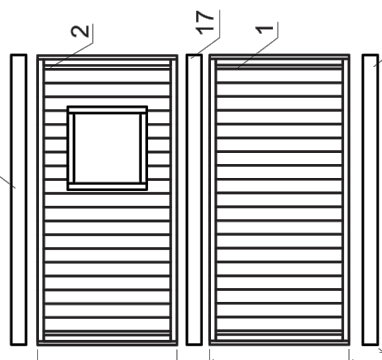
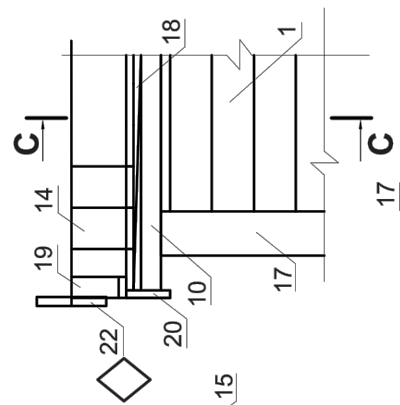
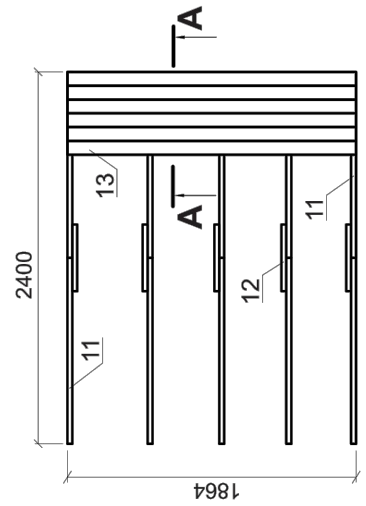
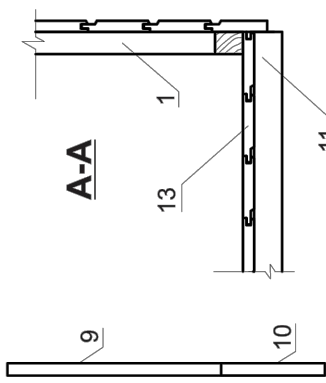
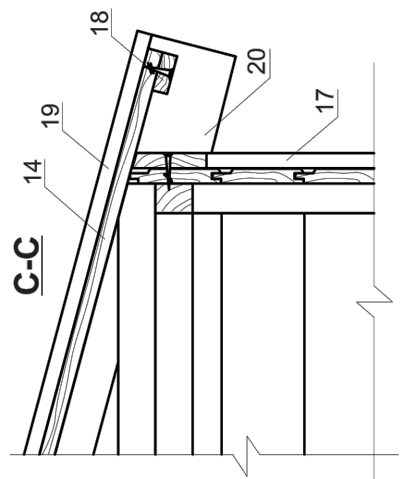

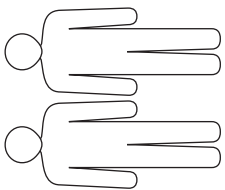

Ø6

Ø3

M10

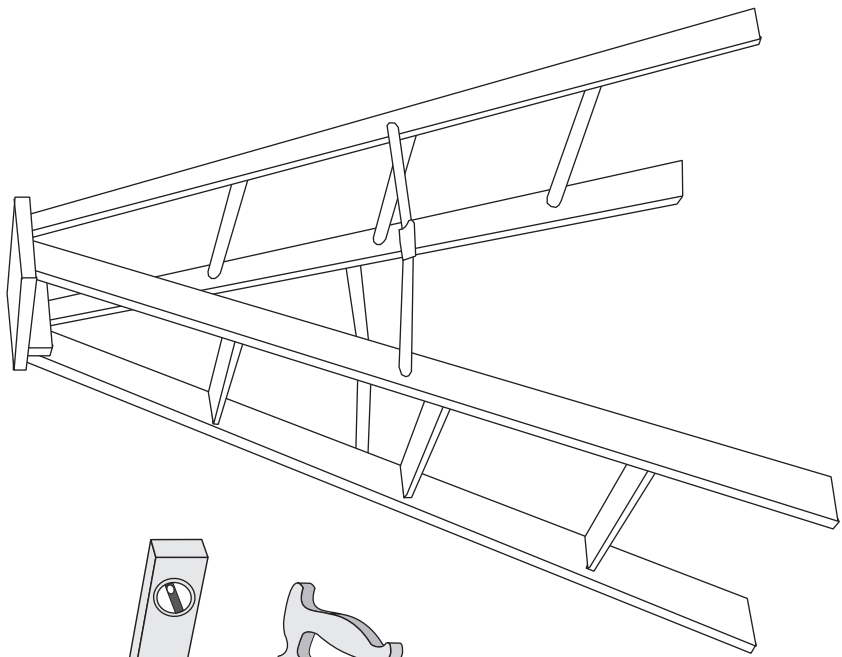
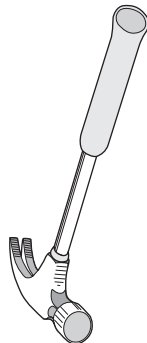
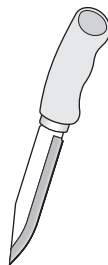
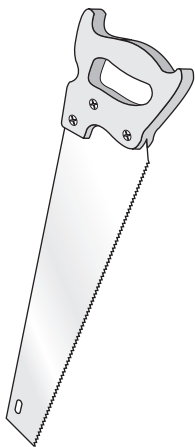
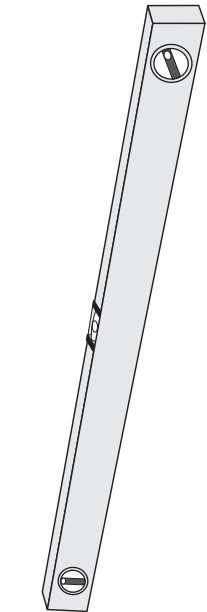
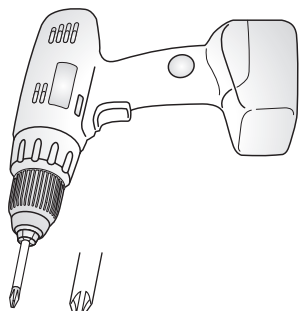
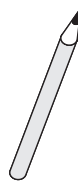
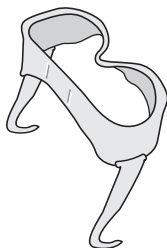
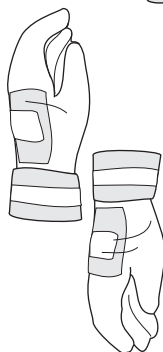
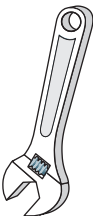

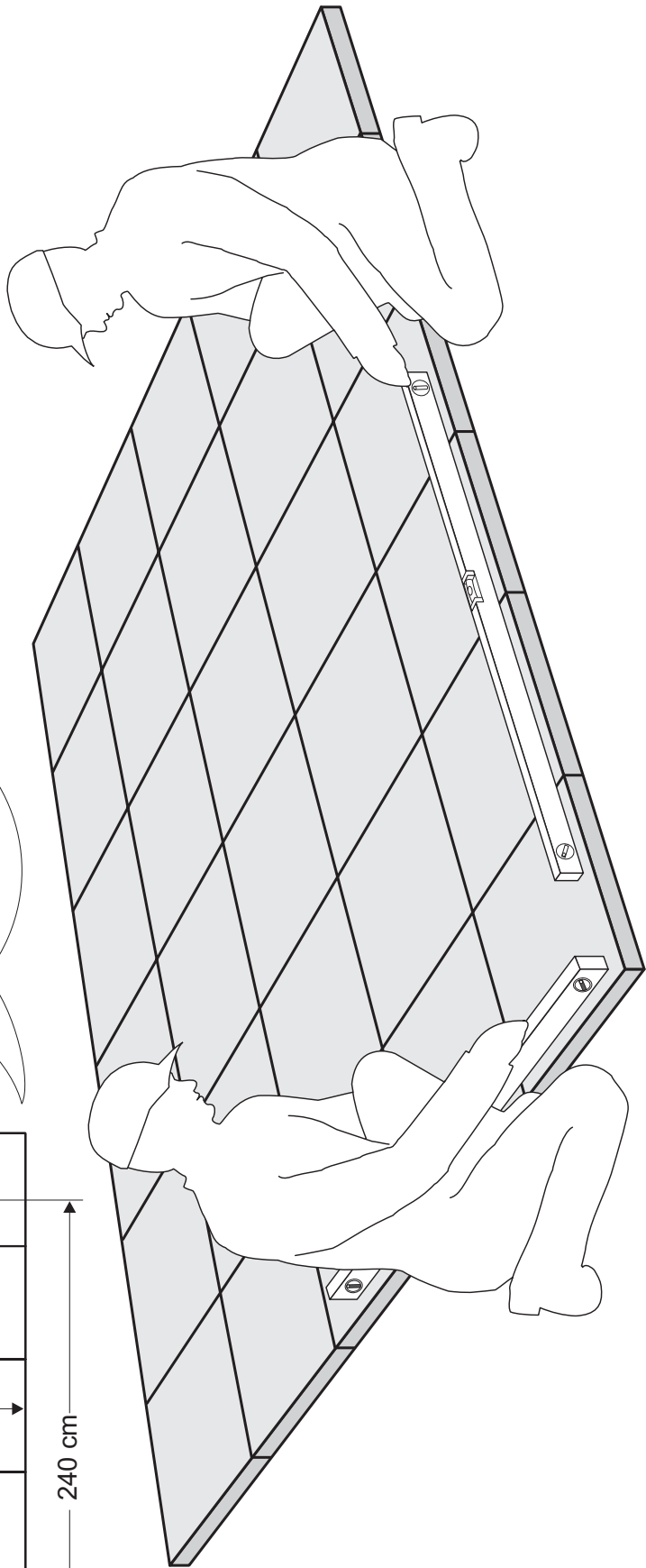
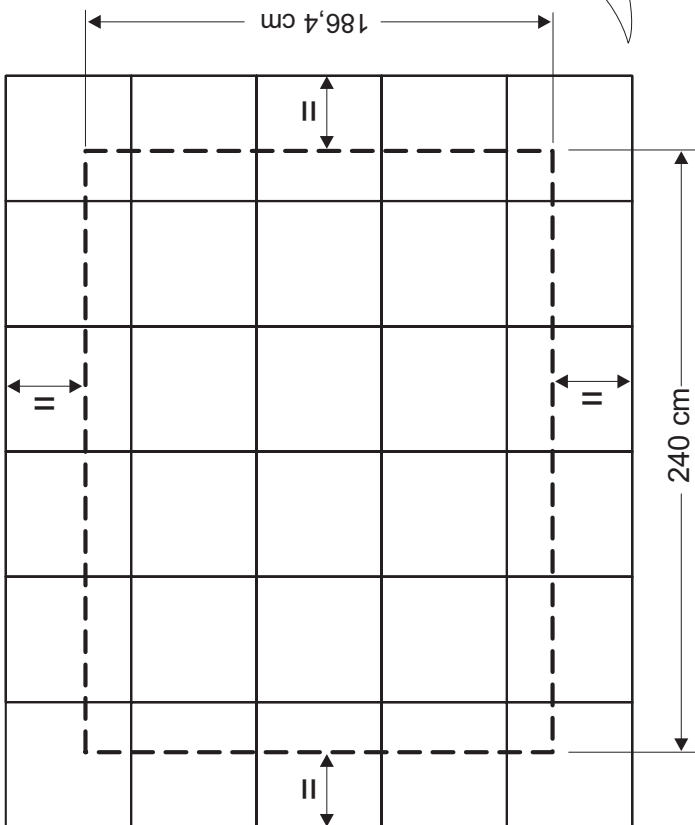
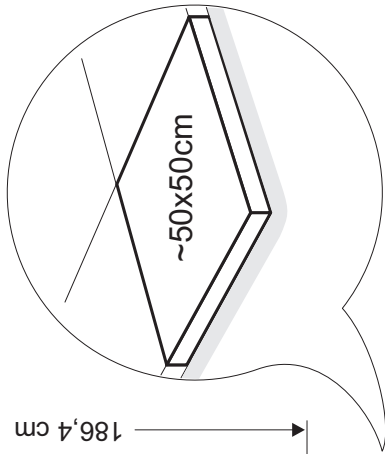
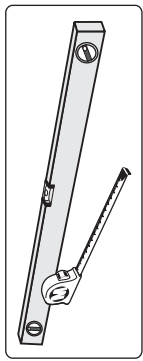

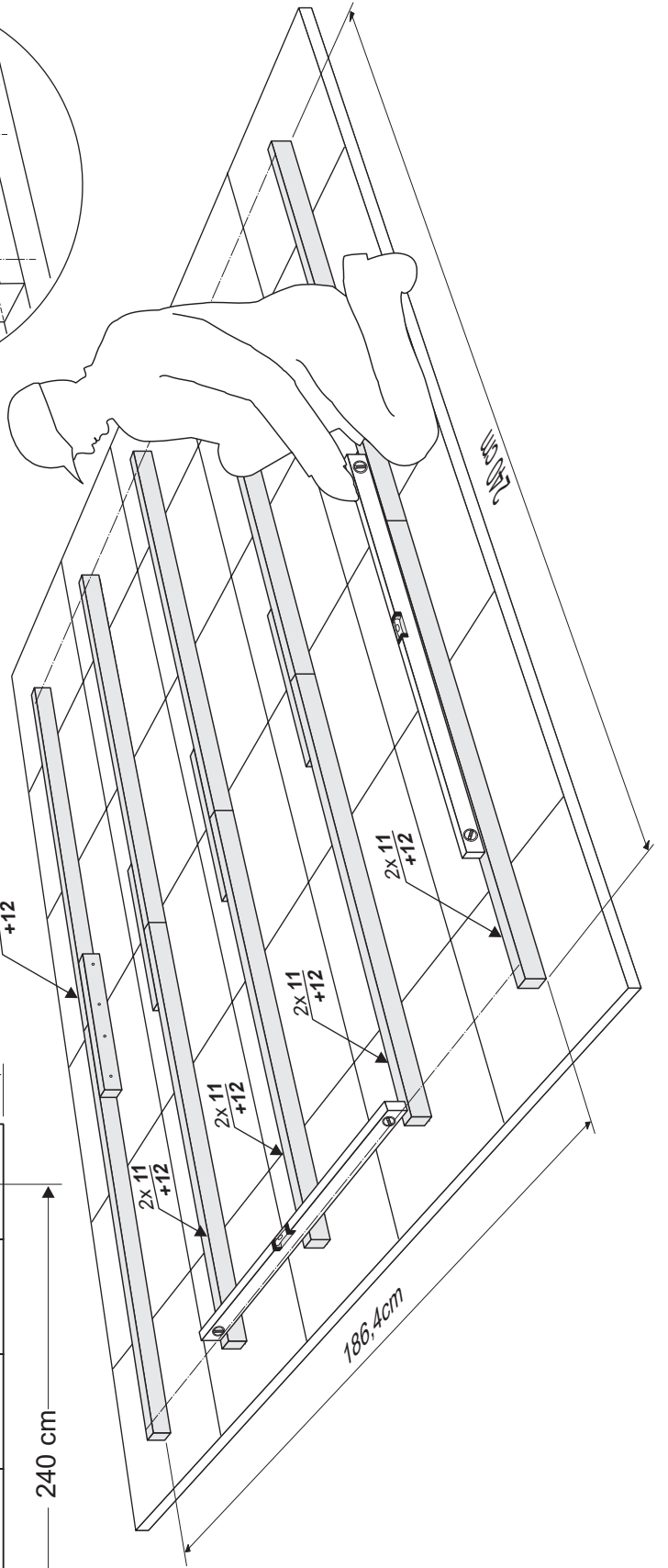
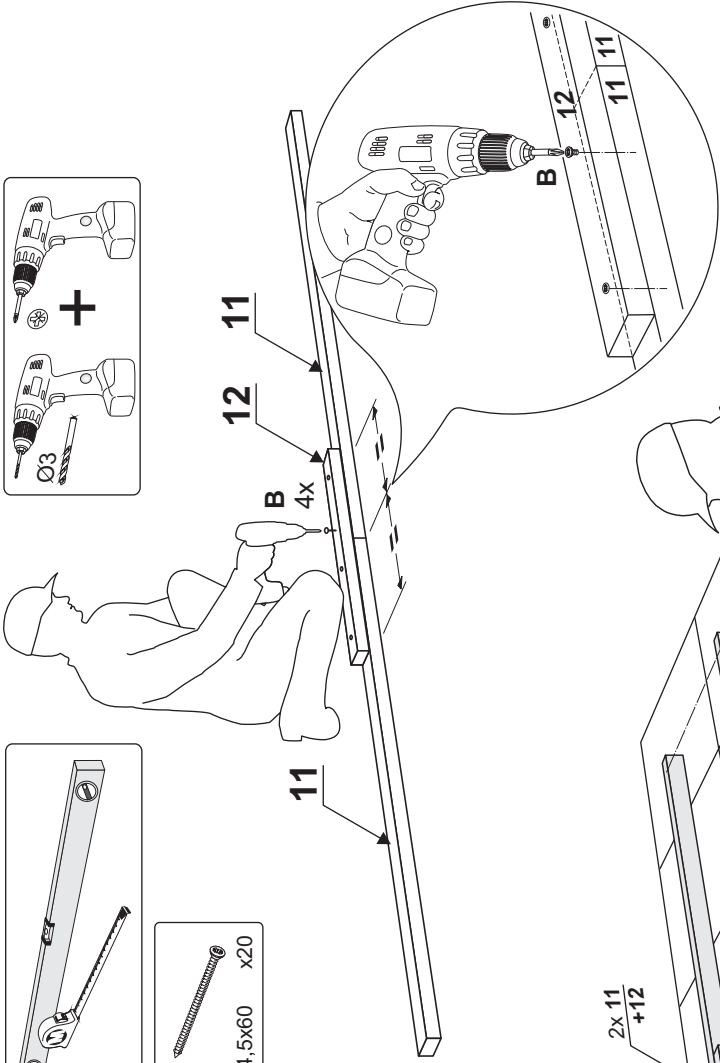
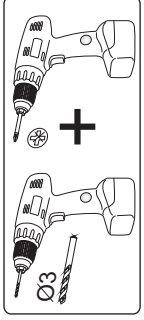
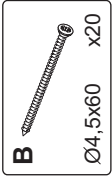
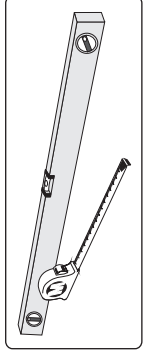
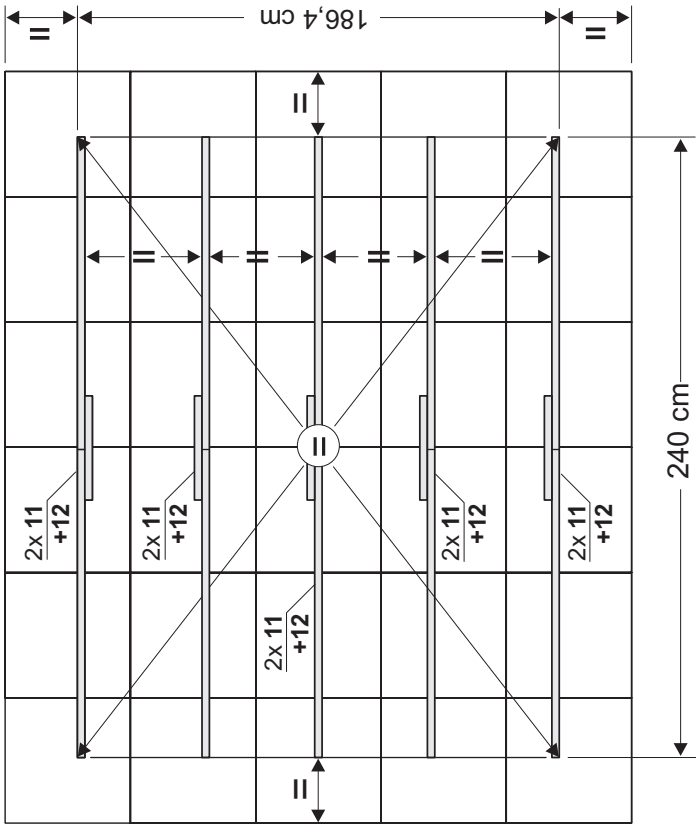

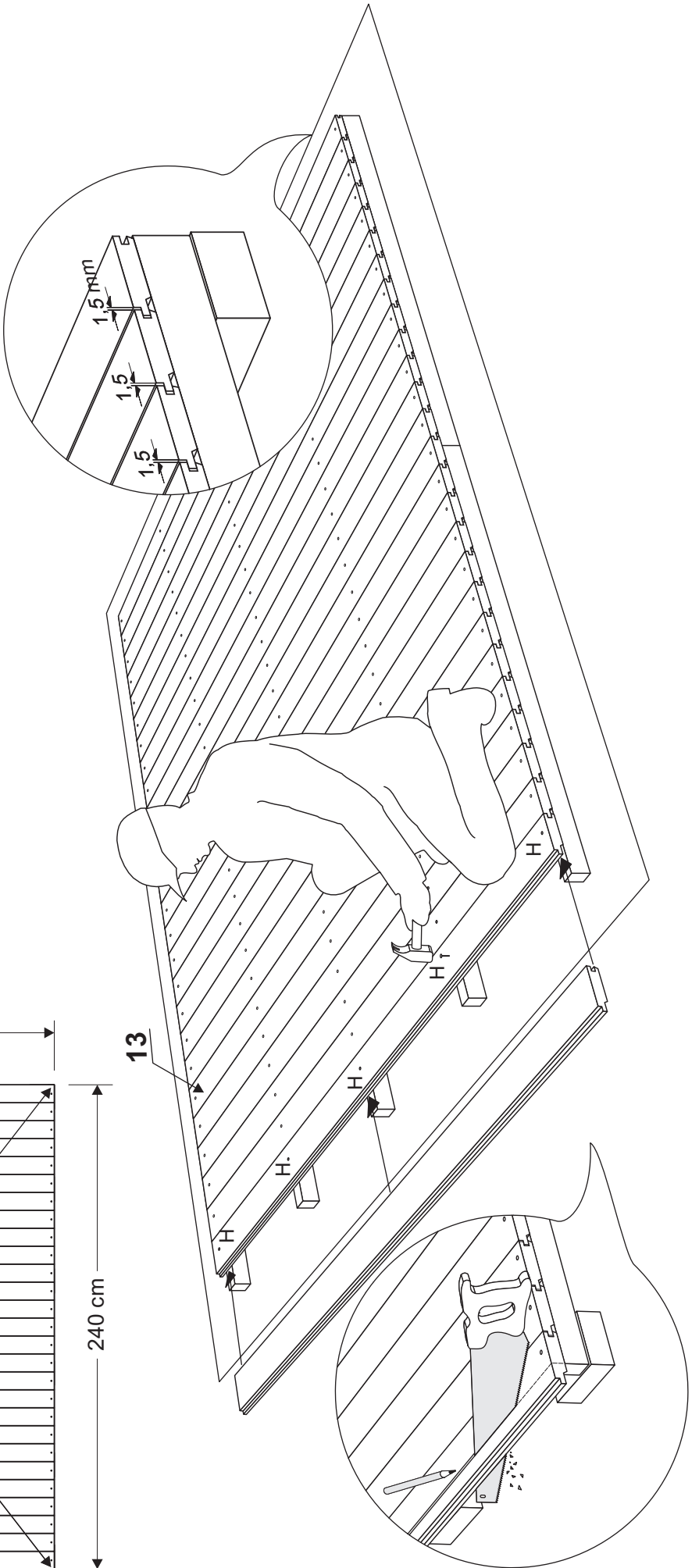
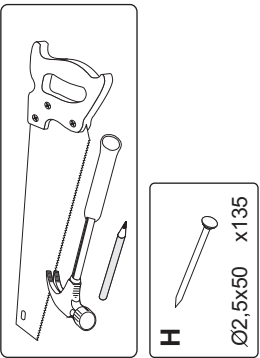
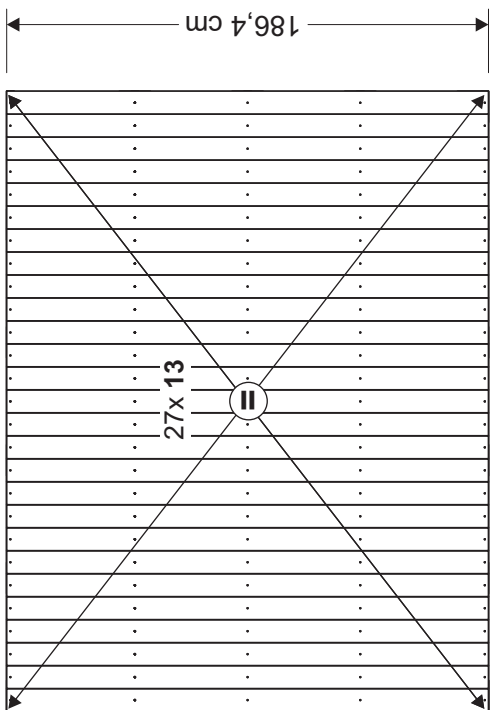

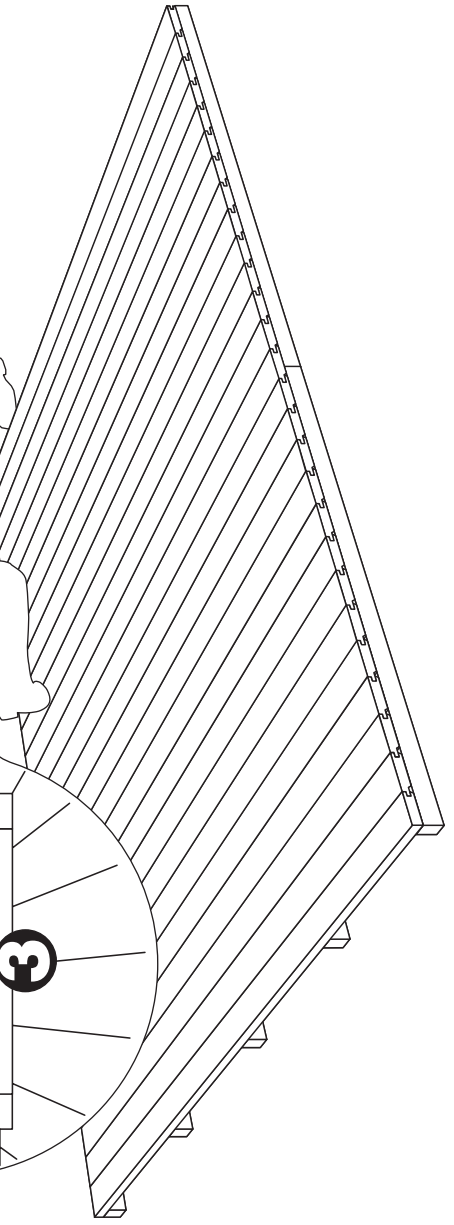
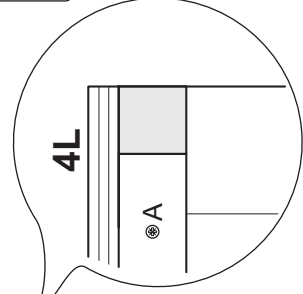
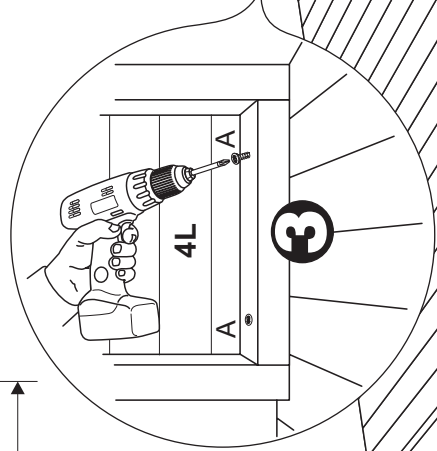
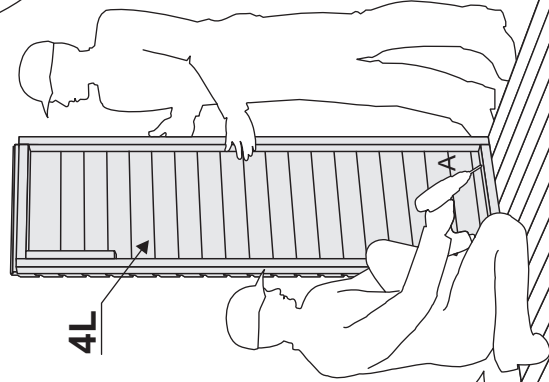
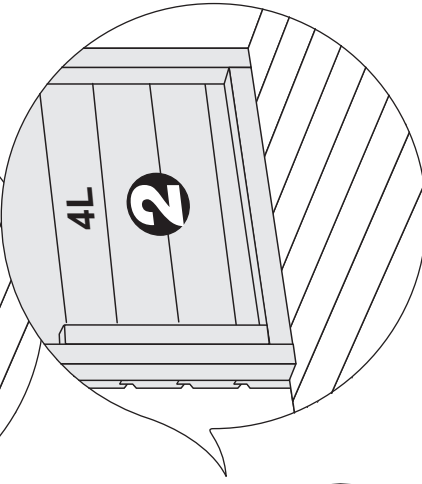
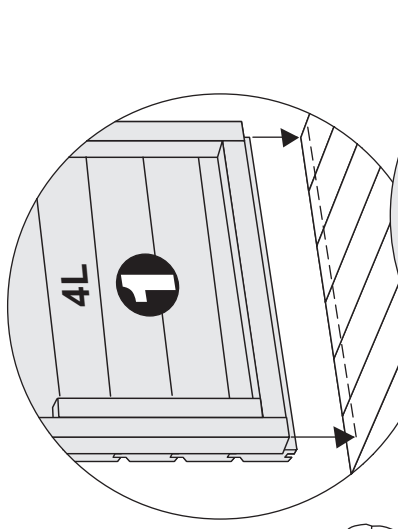
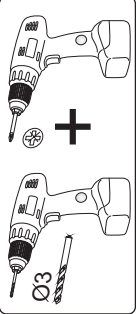
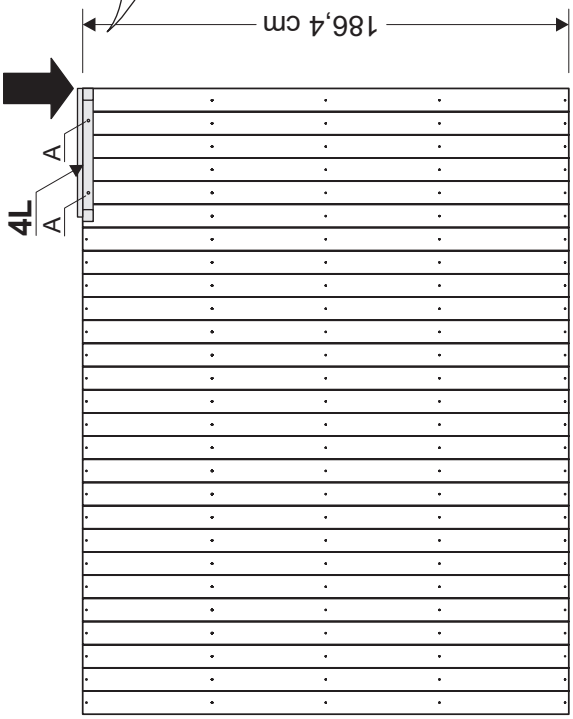

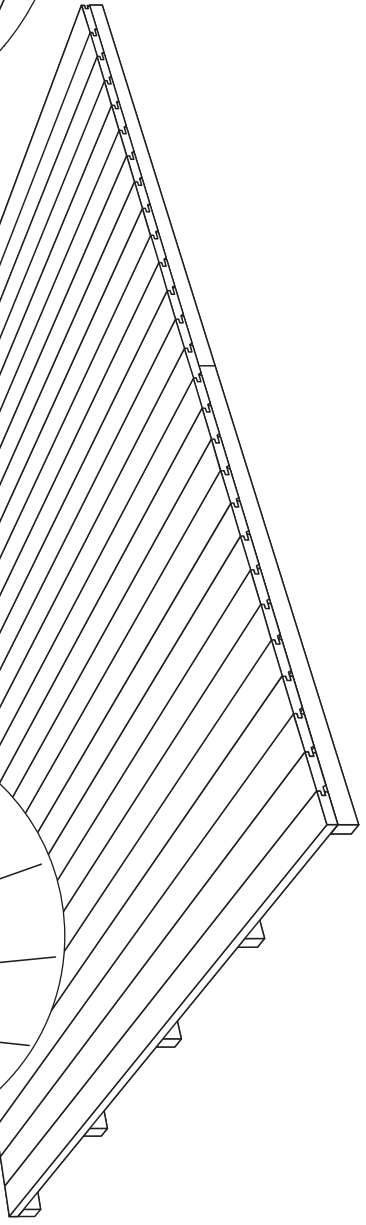
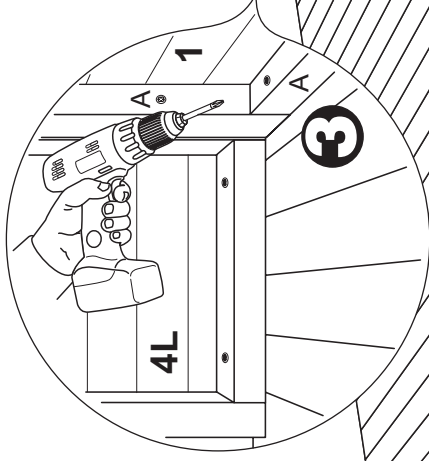
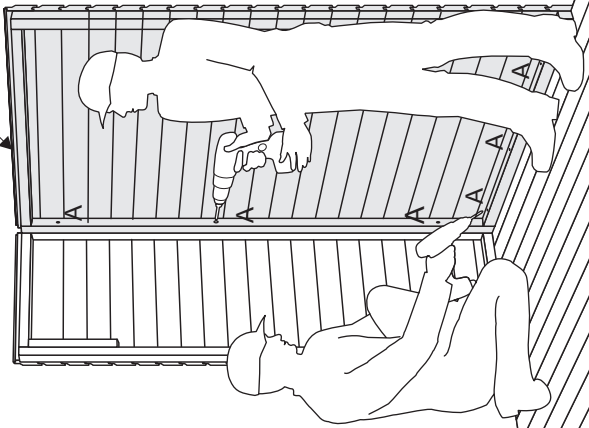
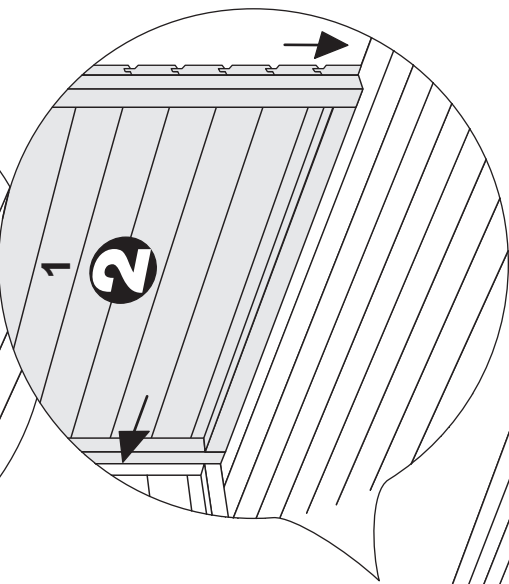
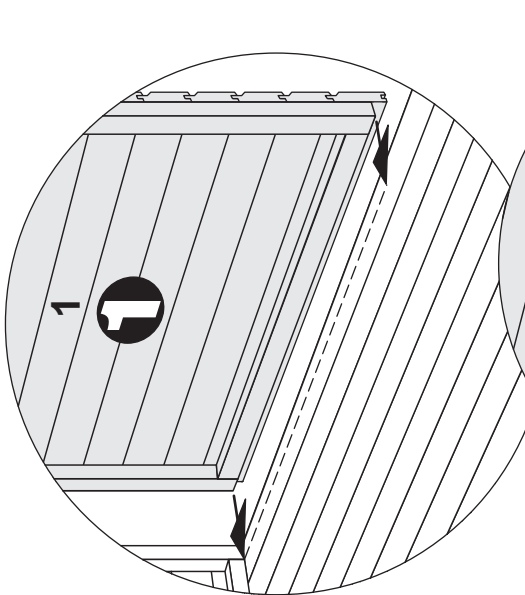
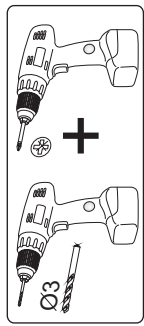
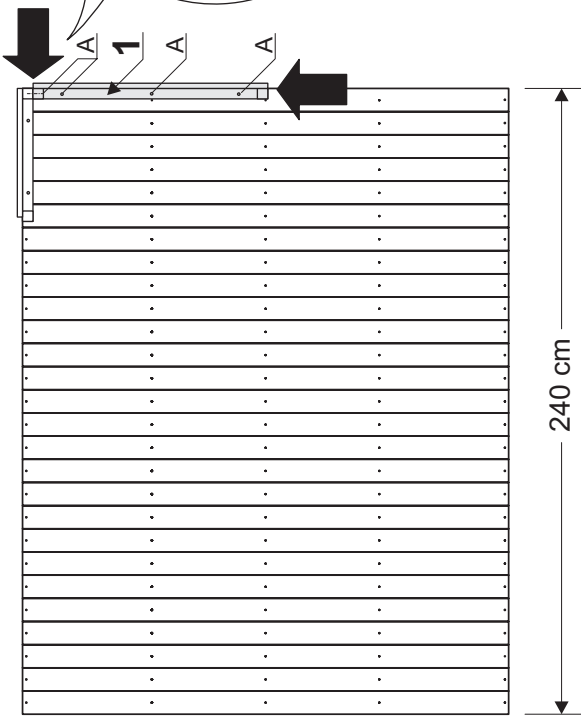

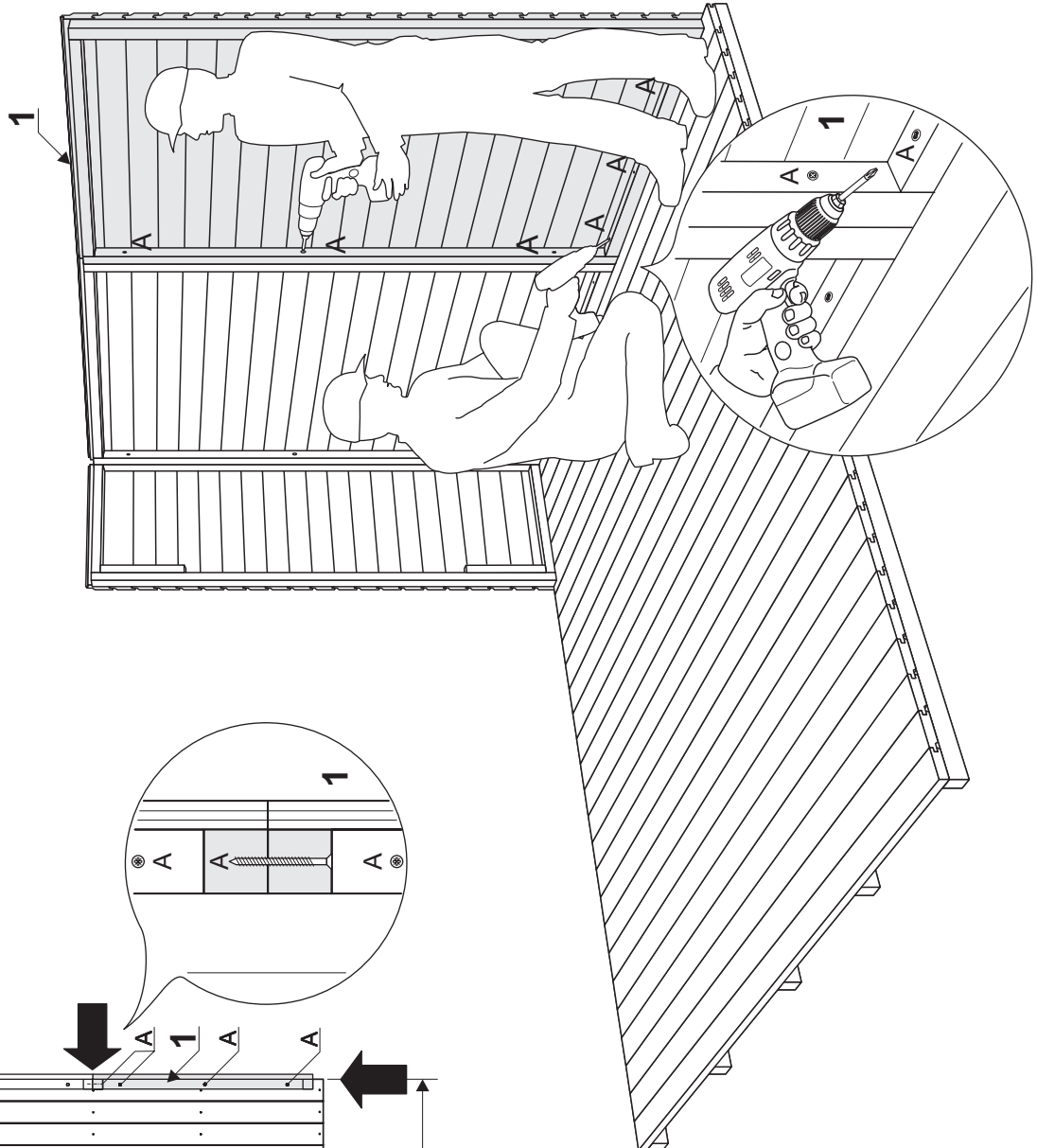
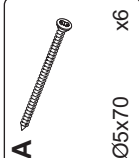
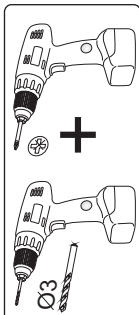
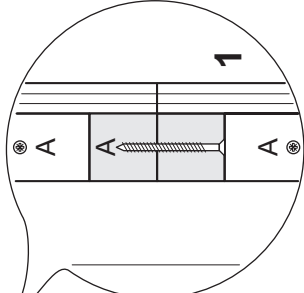
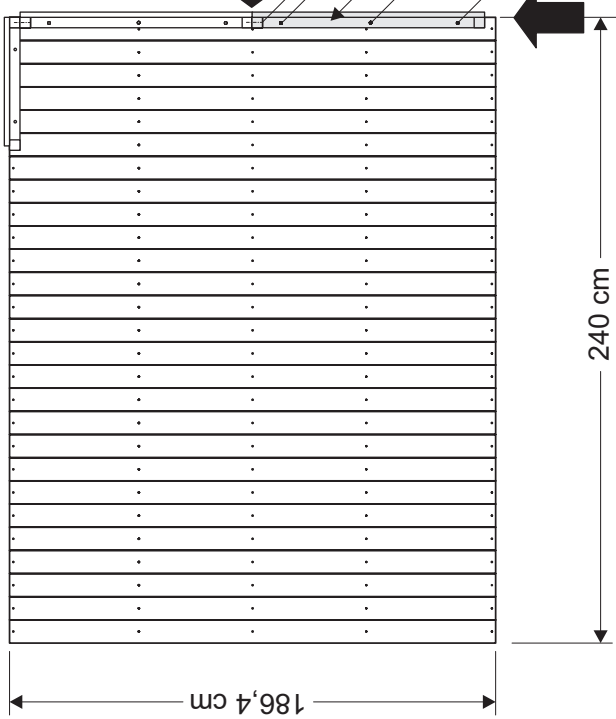

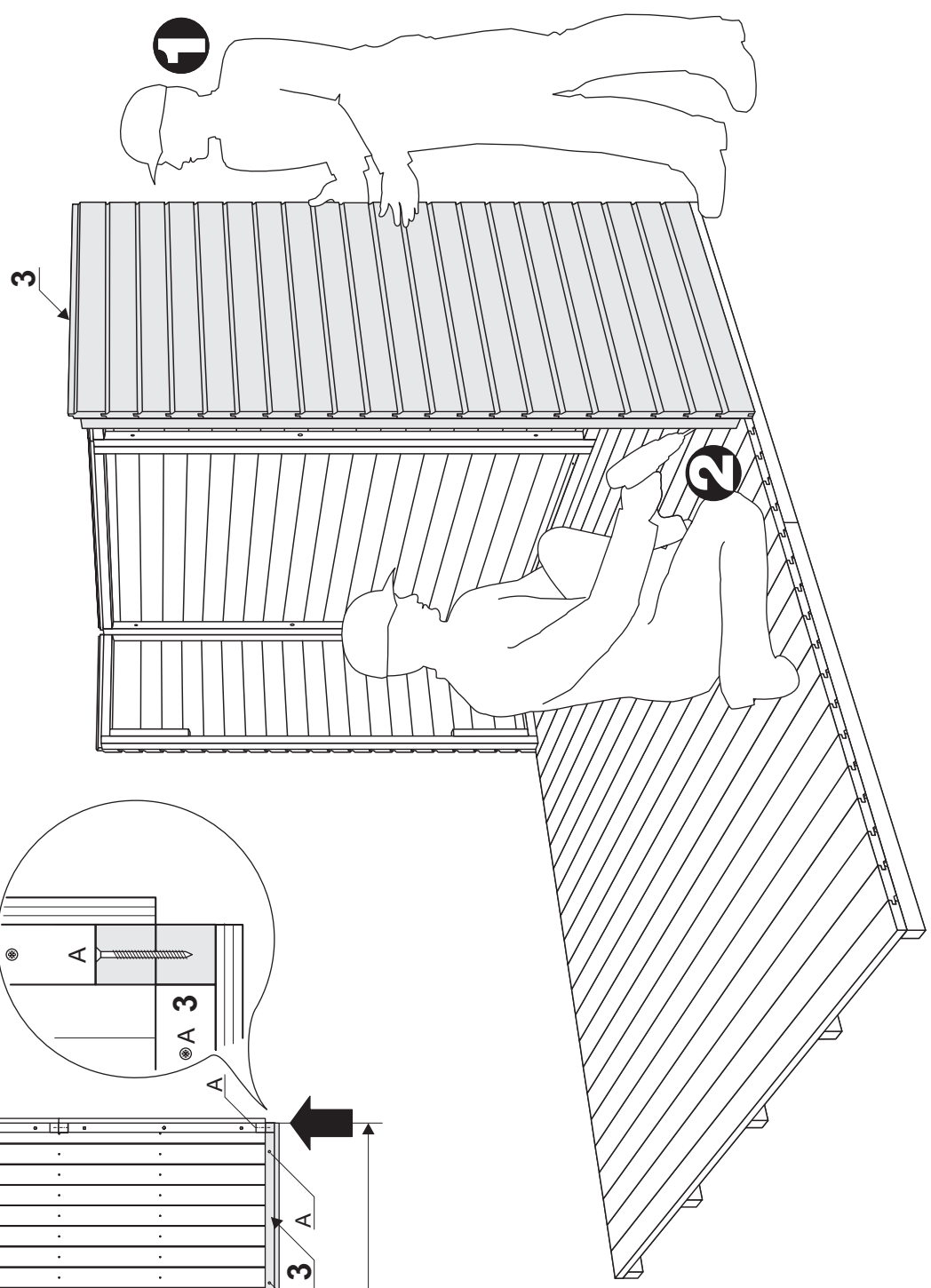
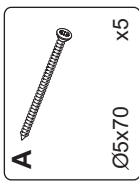
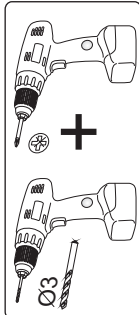
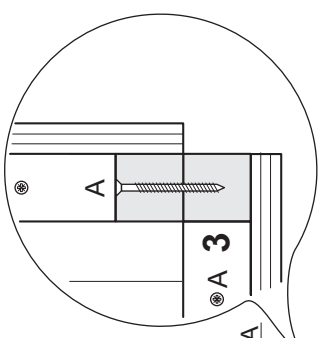
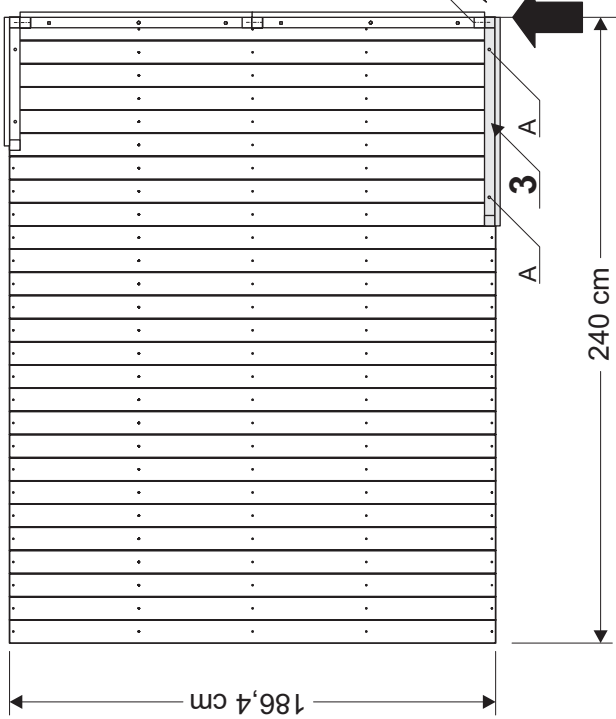

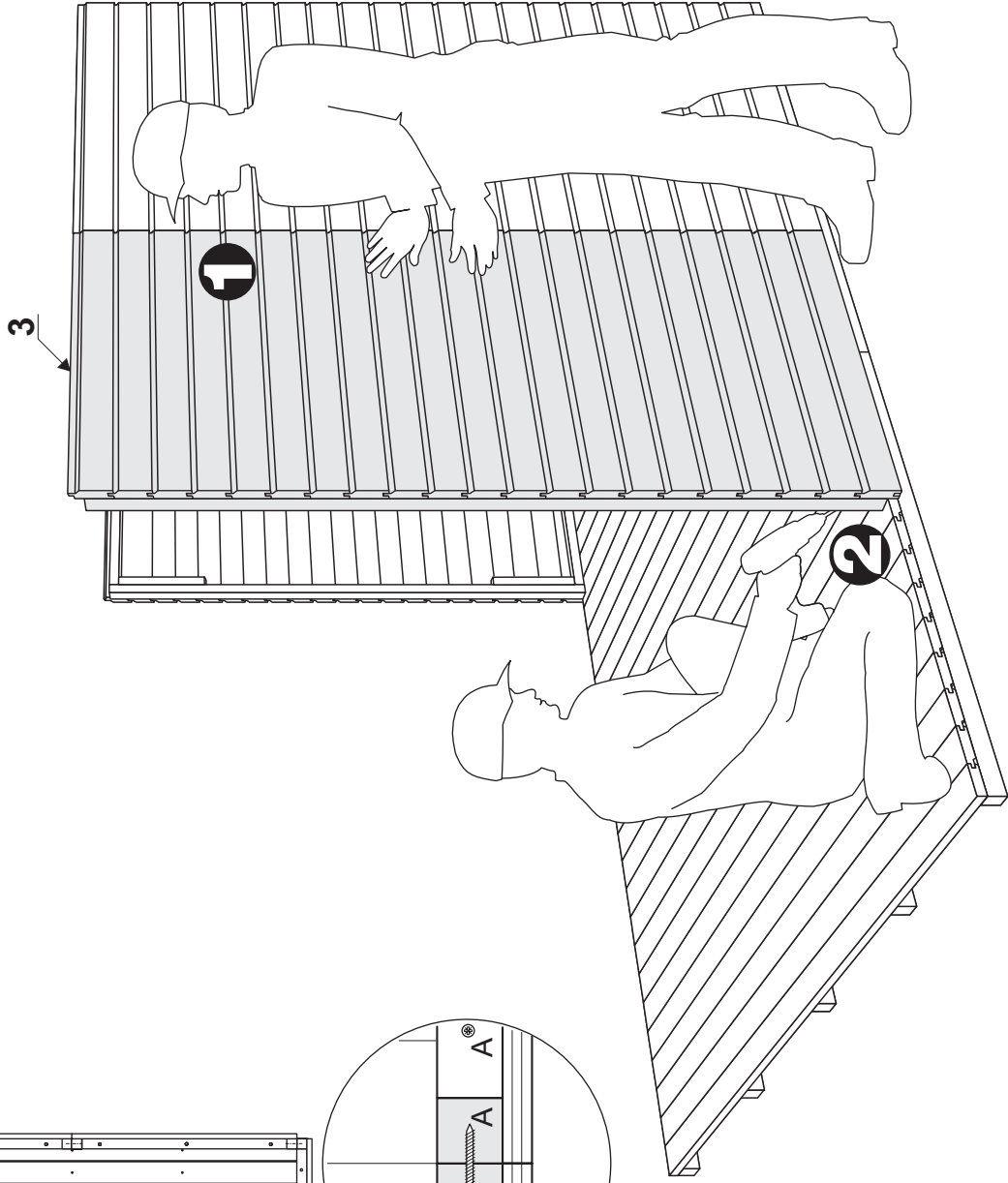
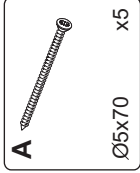
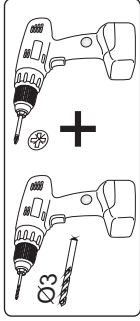
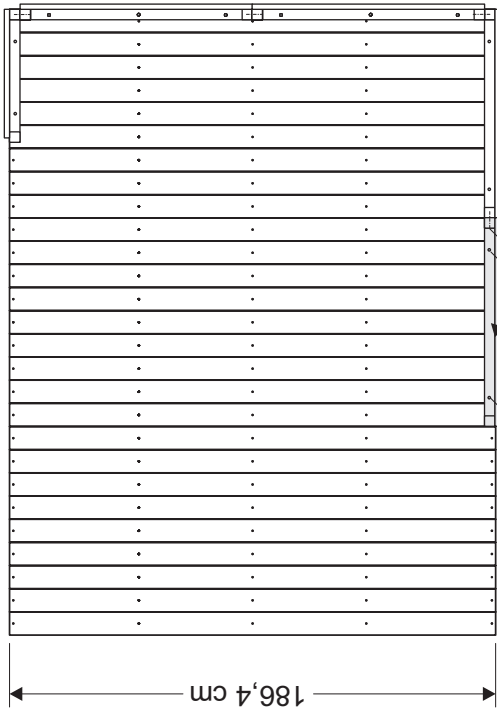

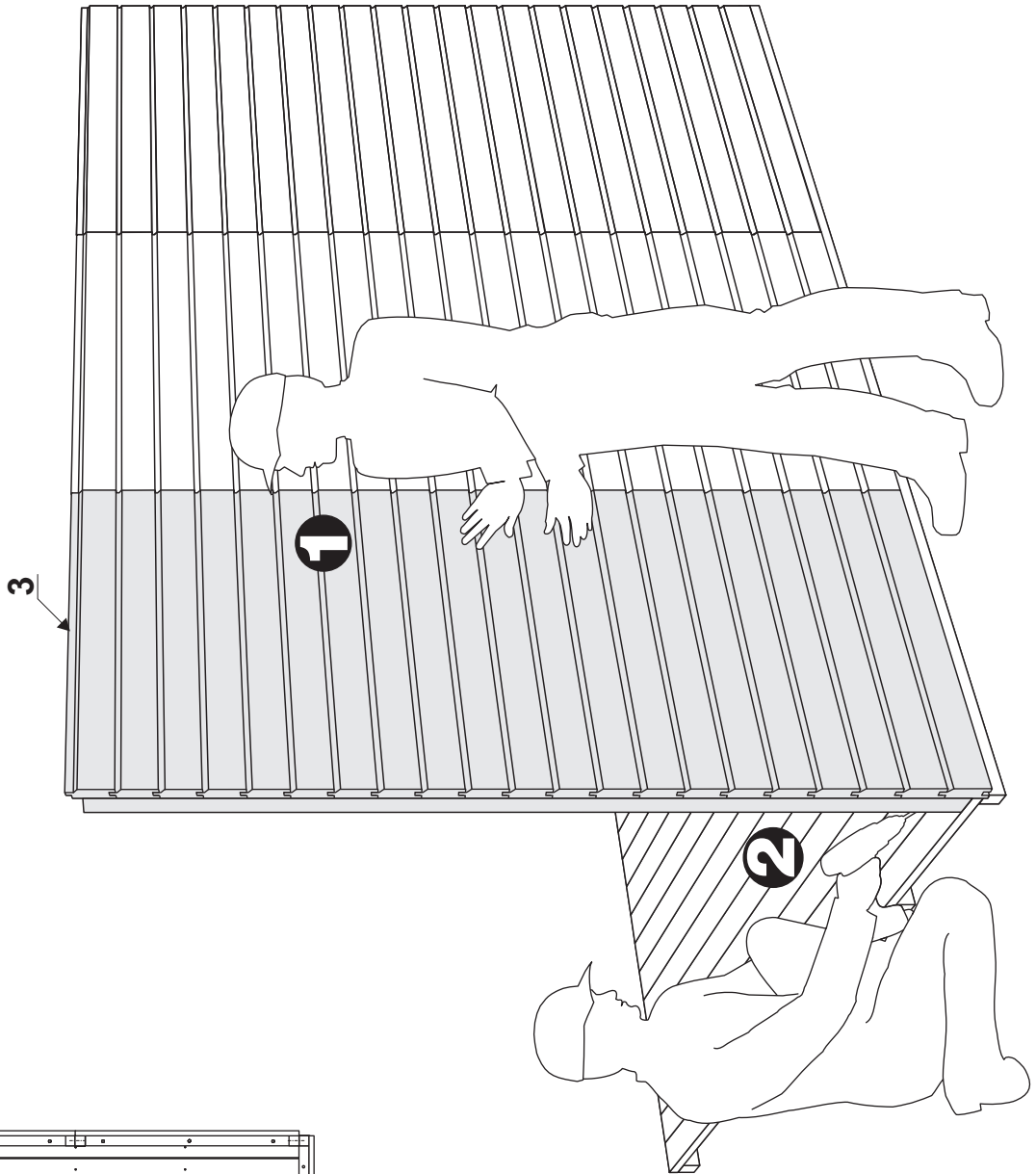
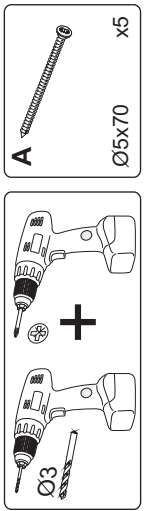
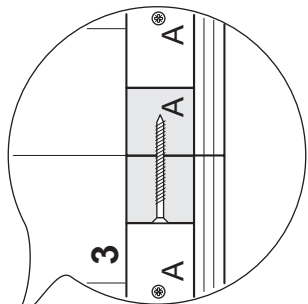
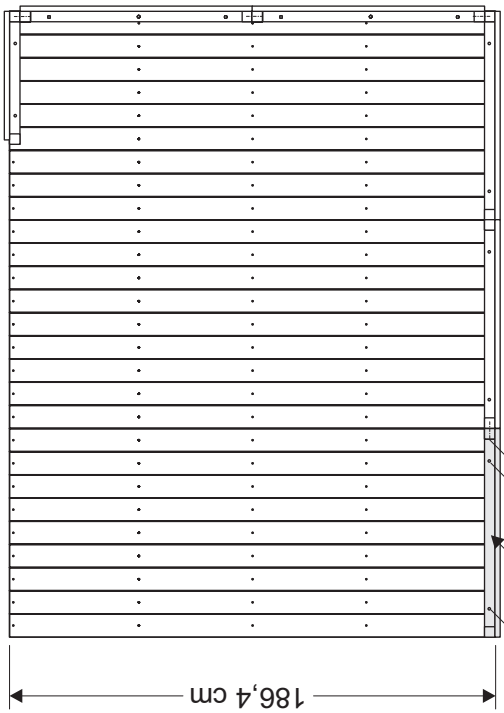

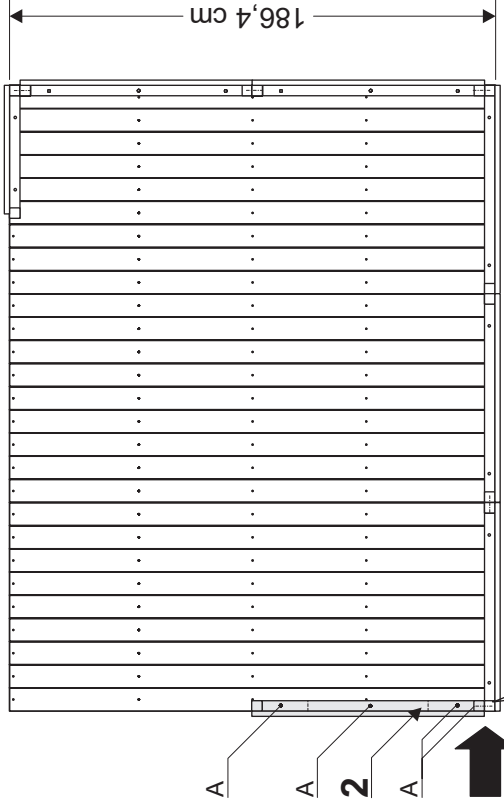

A

Ø5x70

x6

+

Ø3

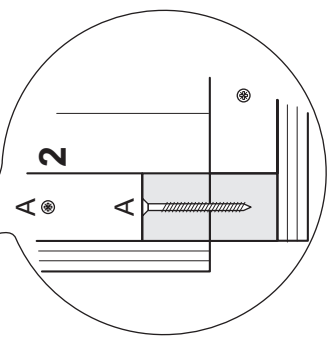
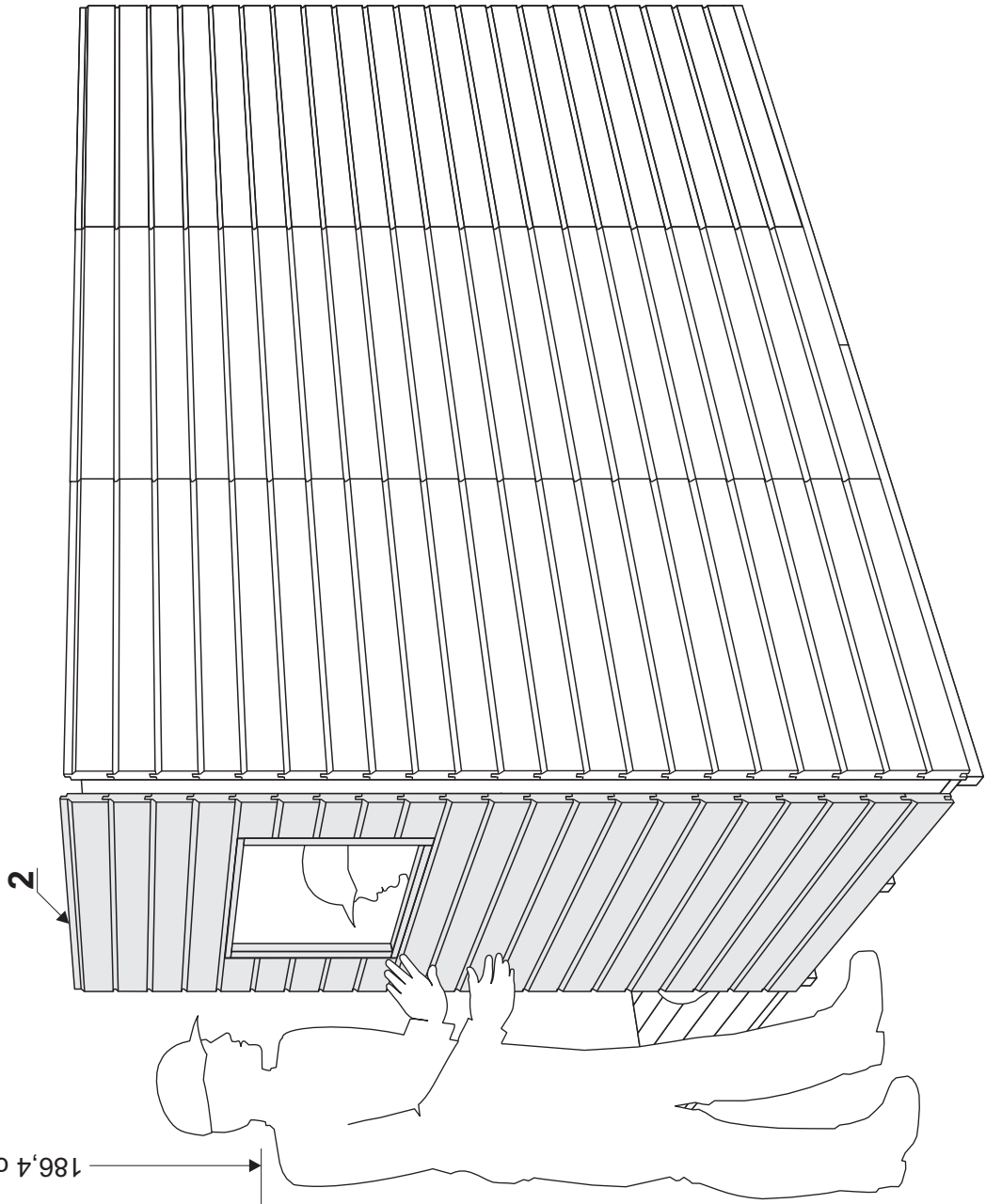

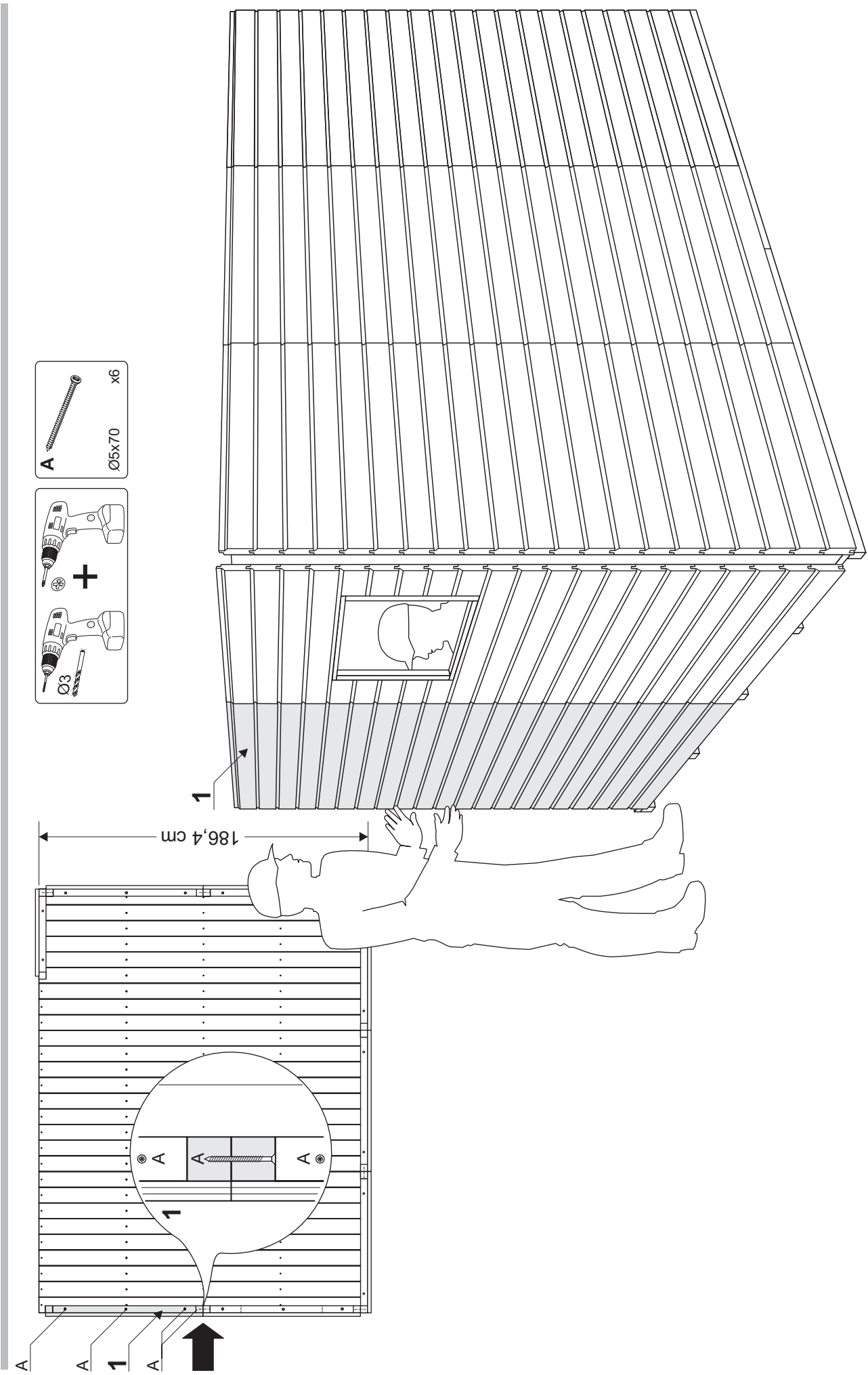

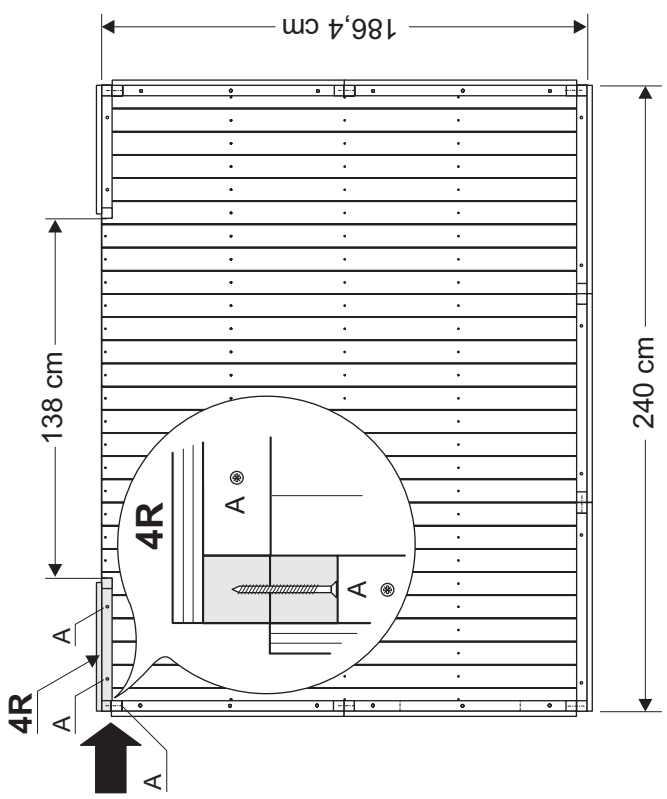
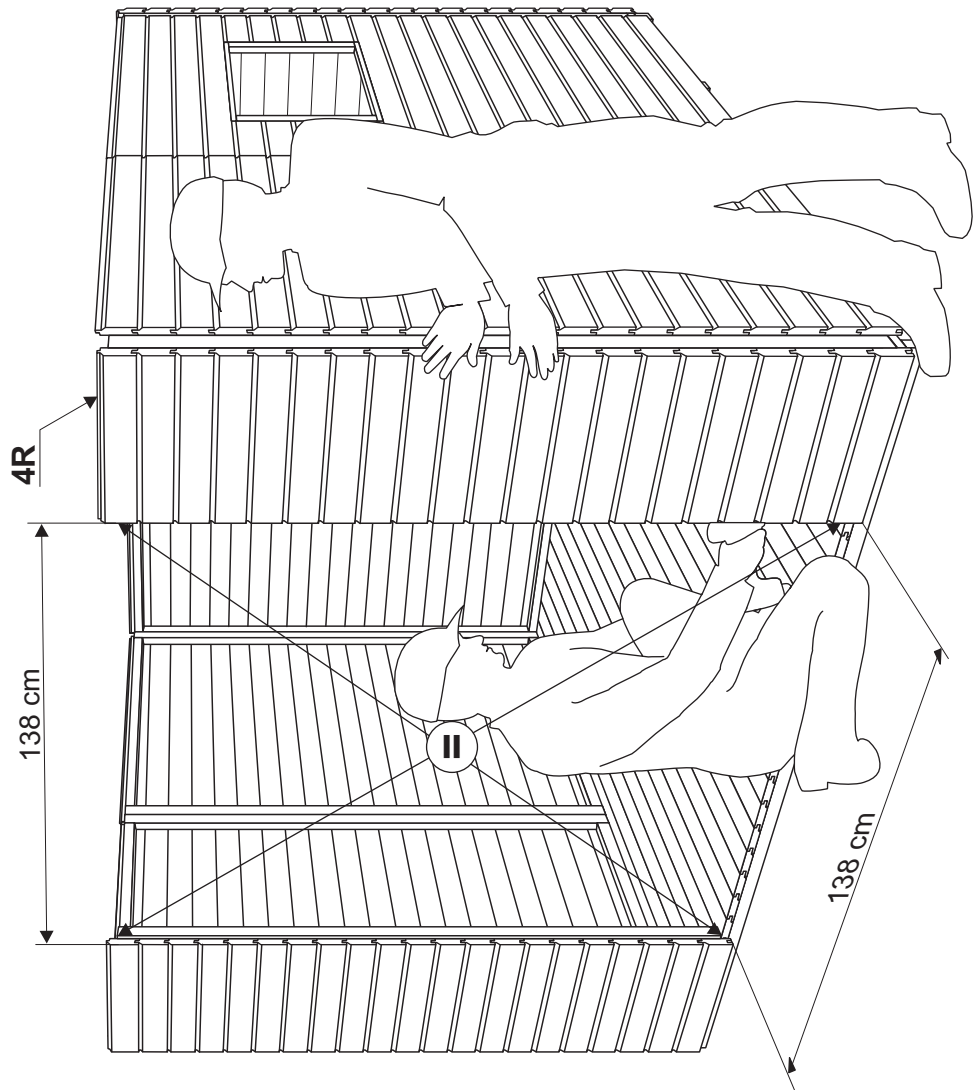
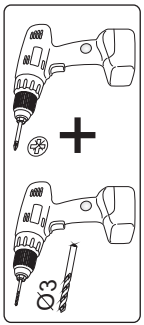
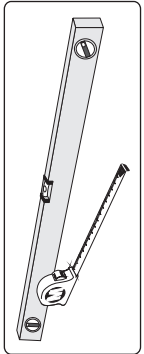
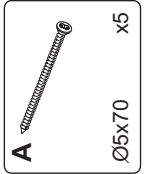

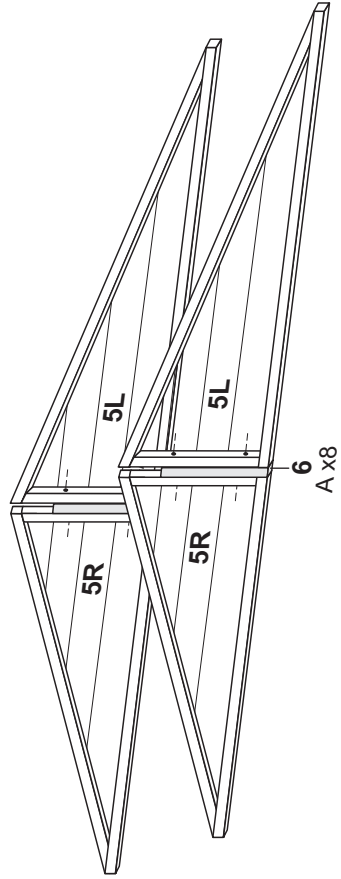
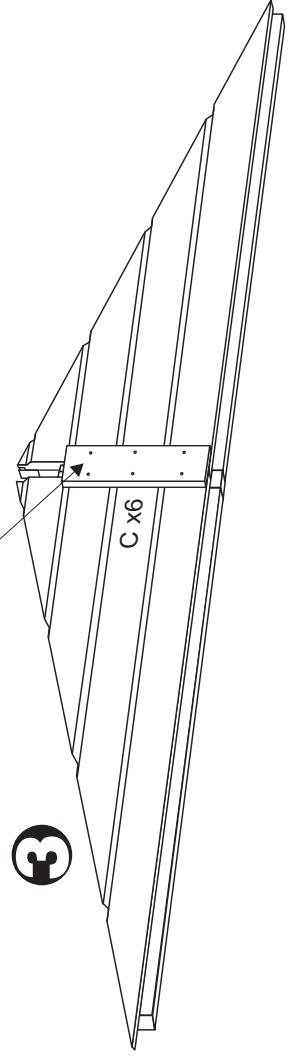
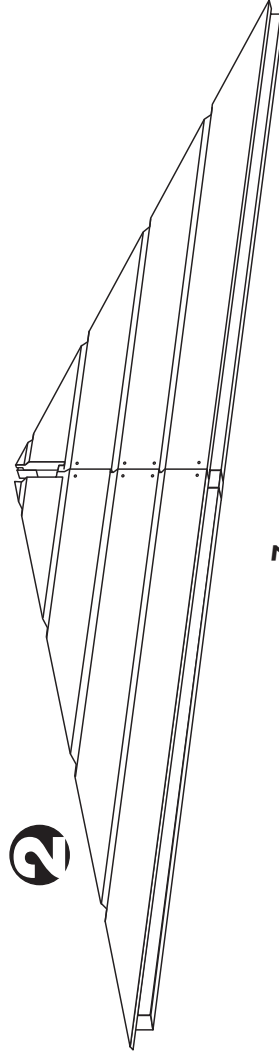
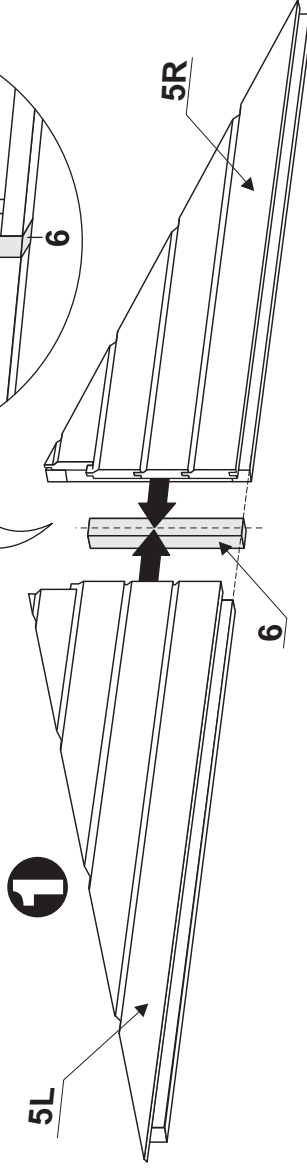
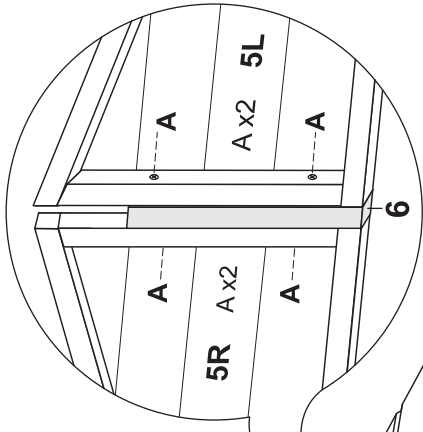
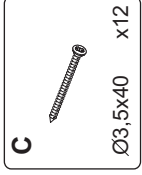
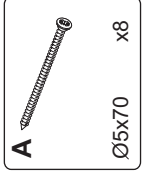
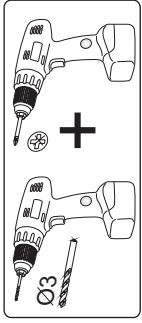
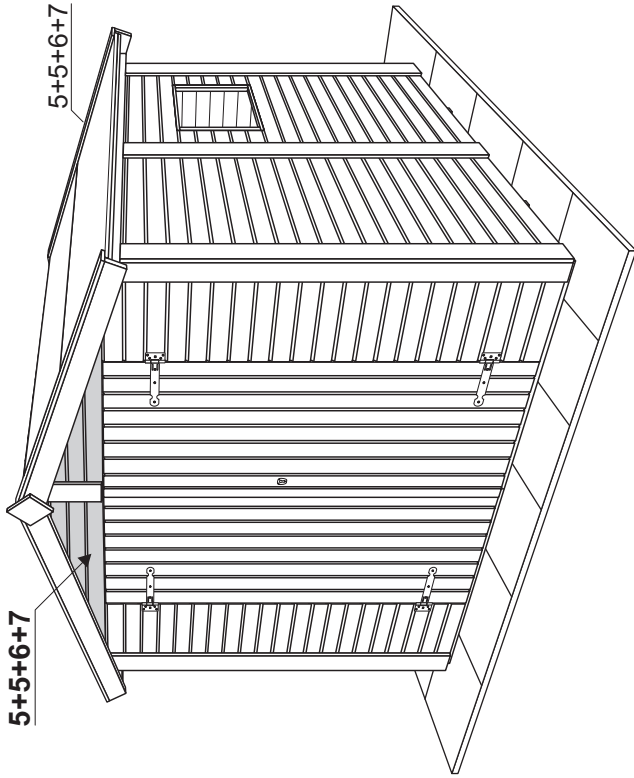

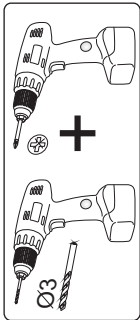

A
Ø5x70 x10

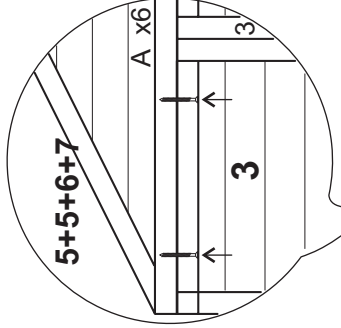
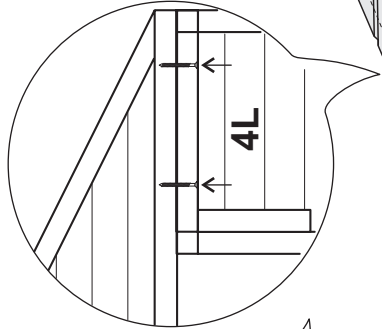
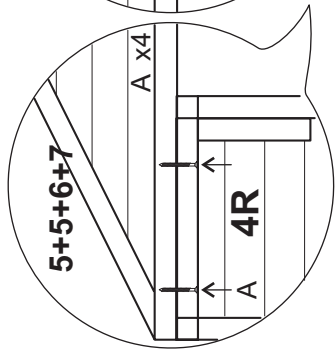

5+5+6+7

5+5+6+7

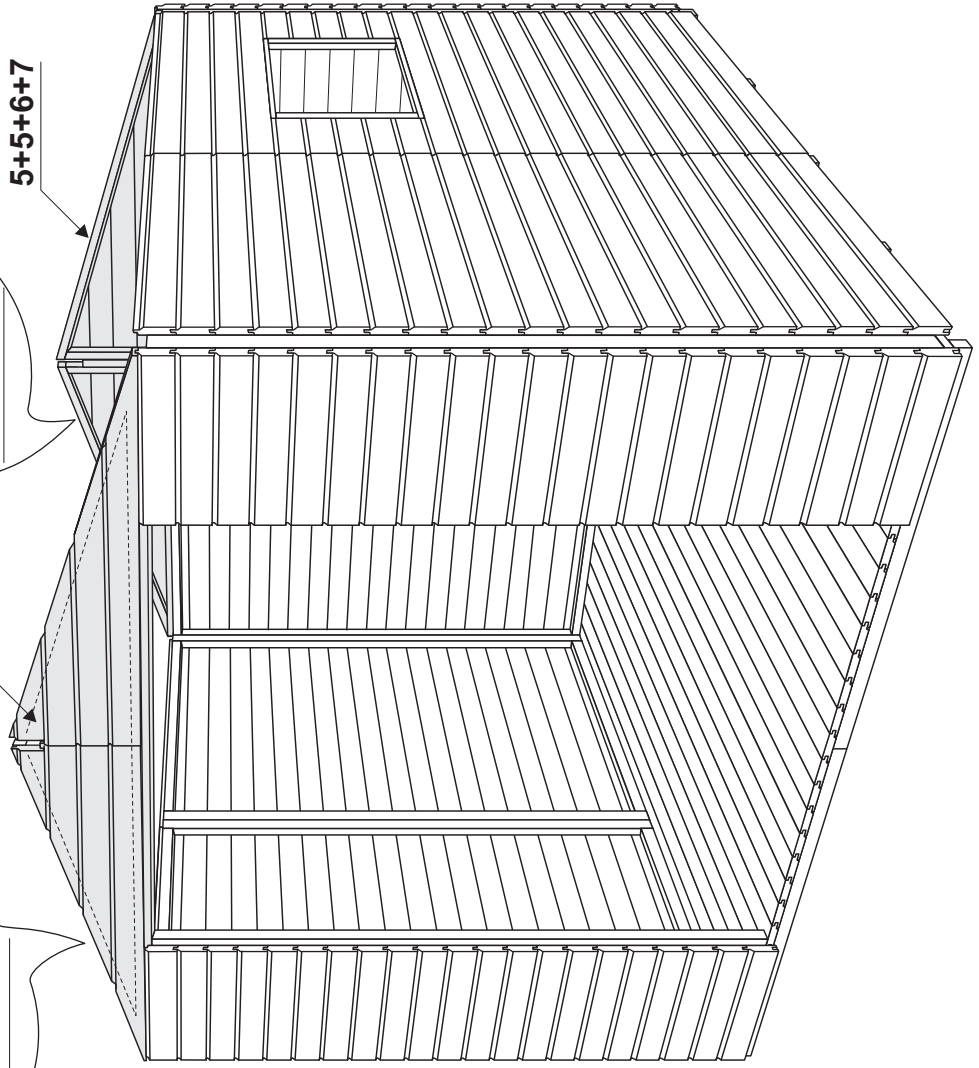

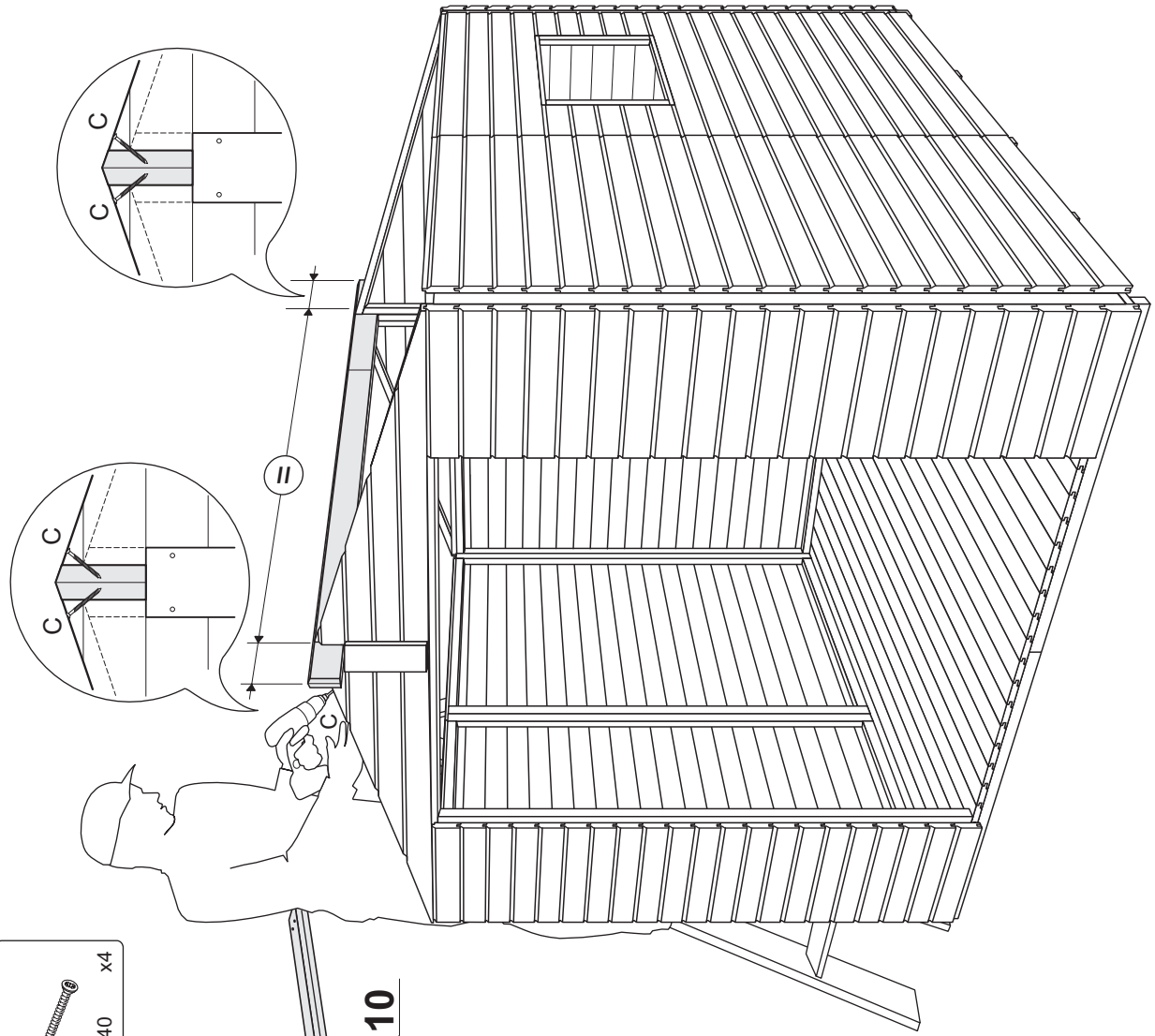
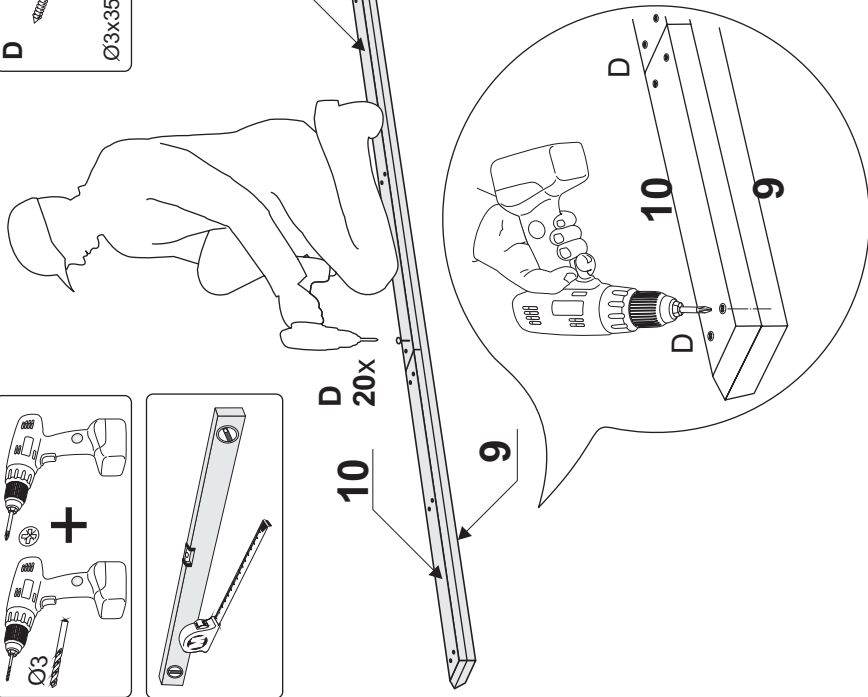
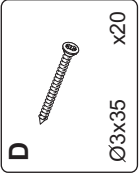
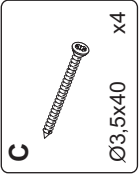
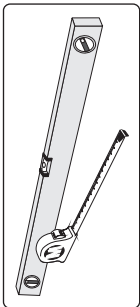
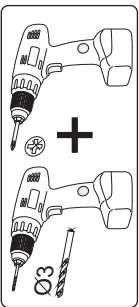

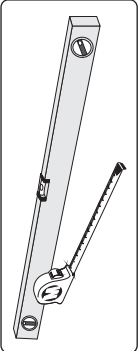

C
Ø3,5x40 x20

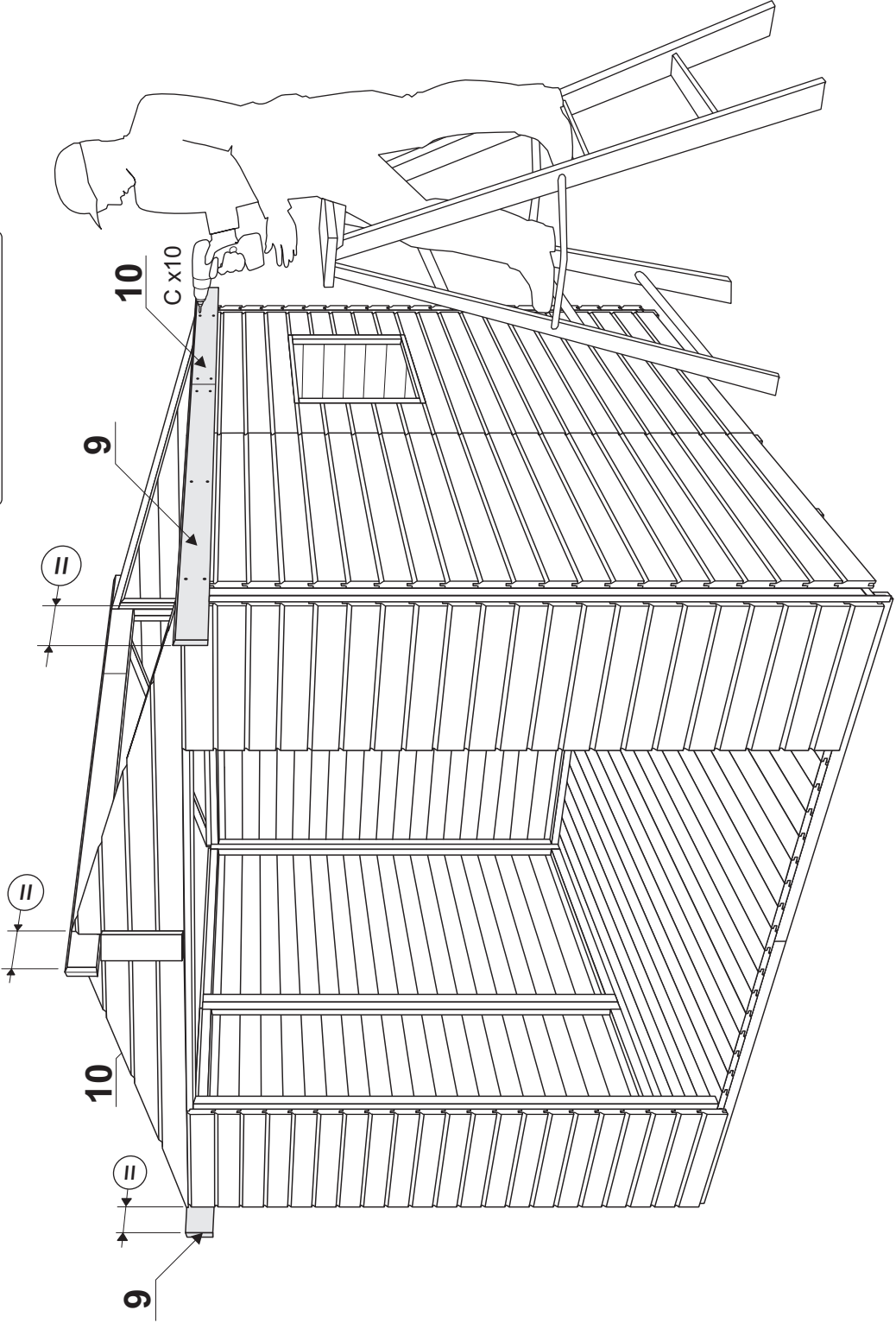
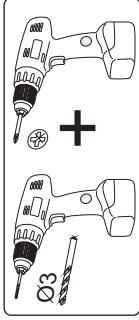

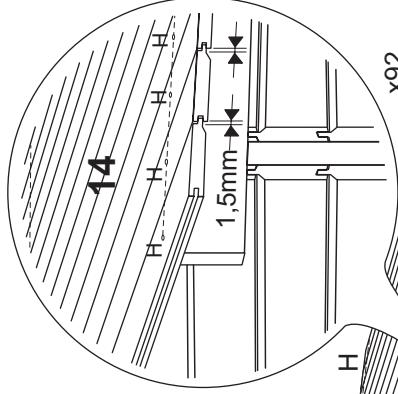
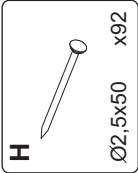
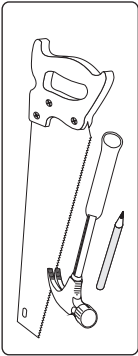

14

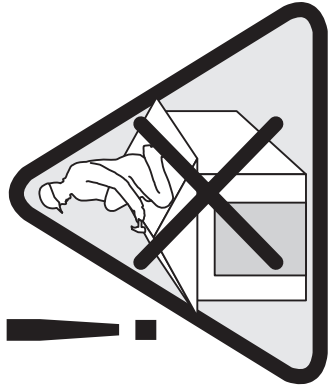
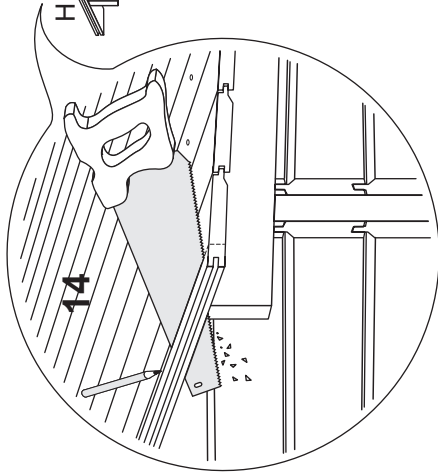
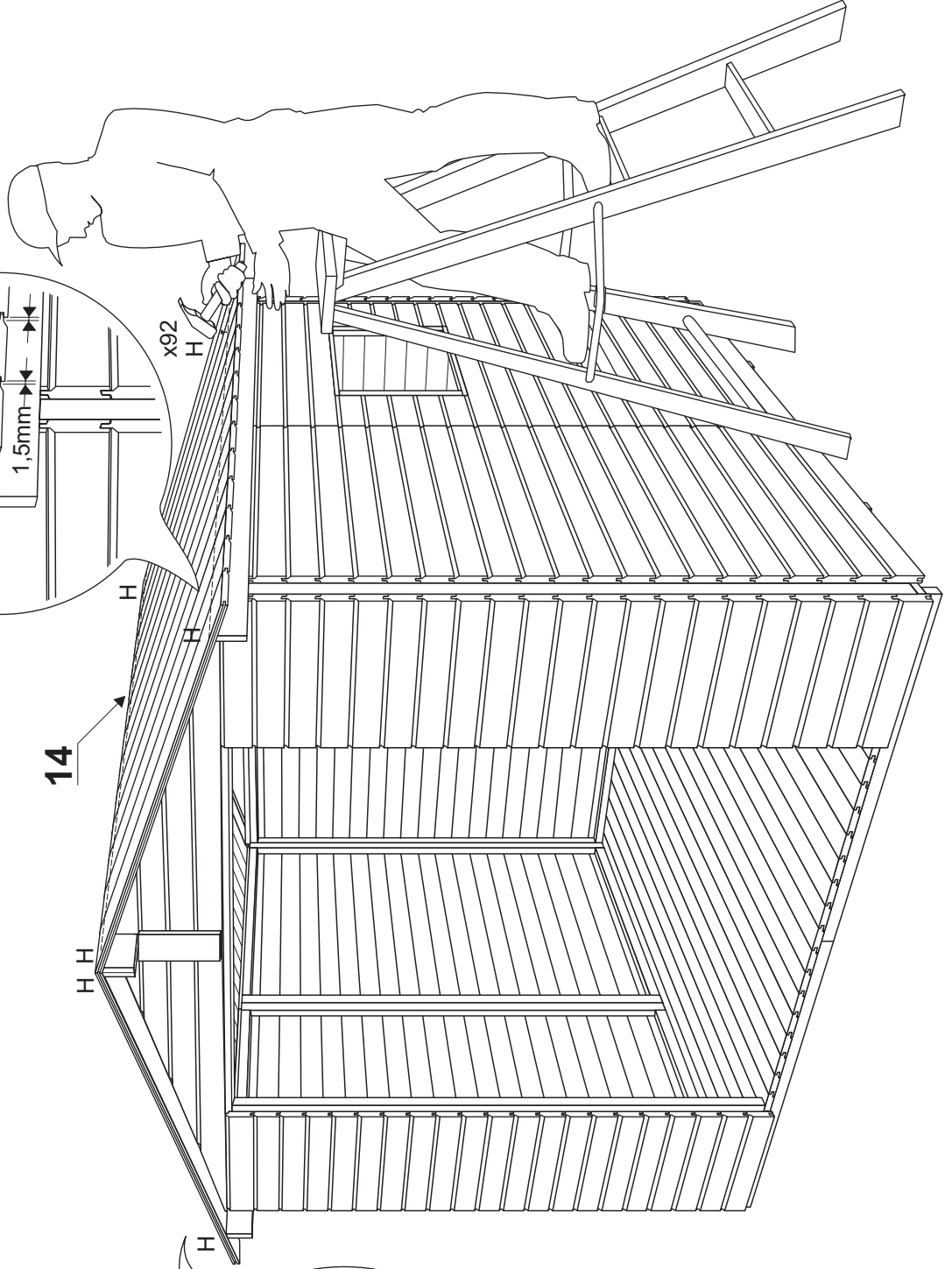

!

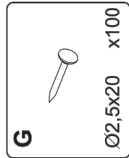

OPTIONAL !!!



OPTIONAL !!!

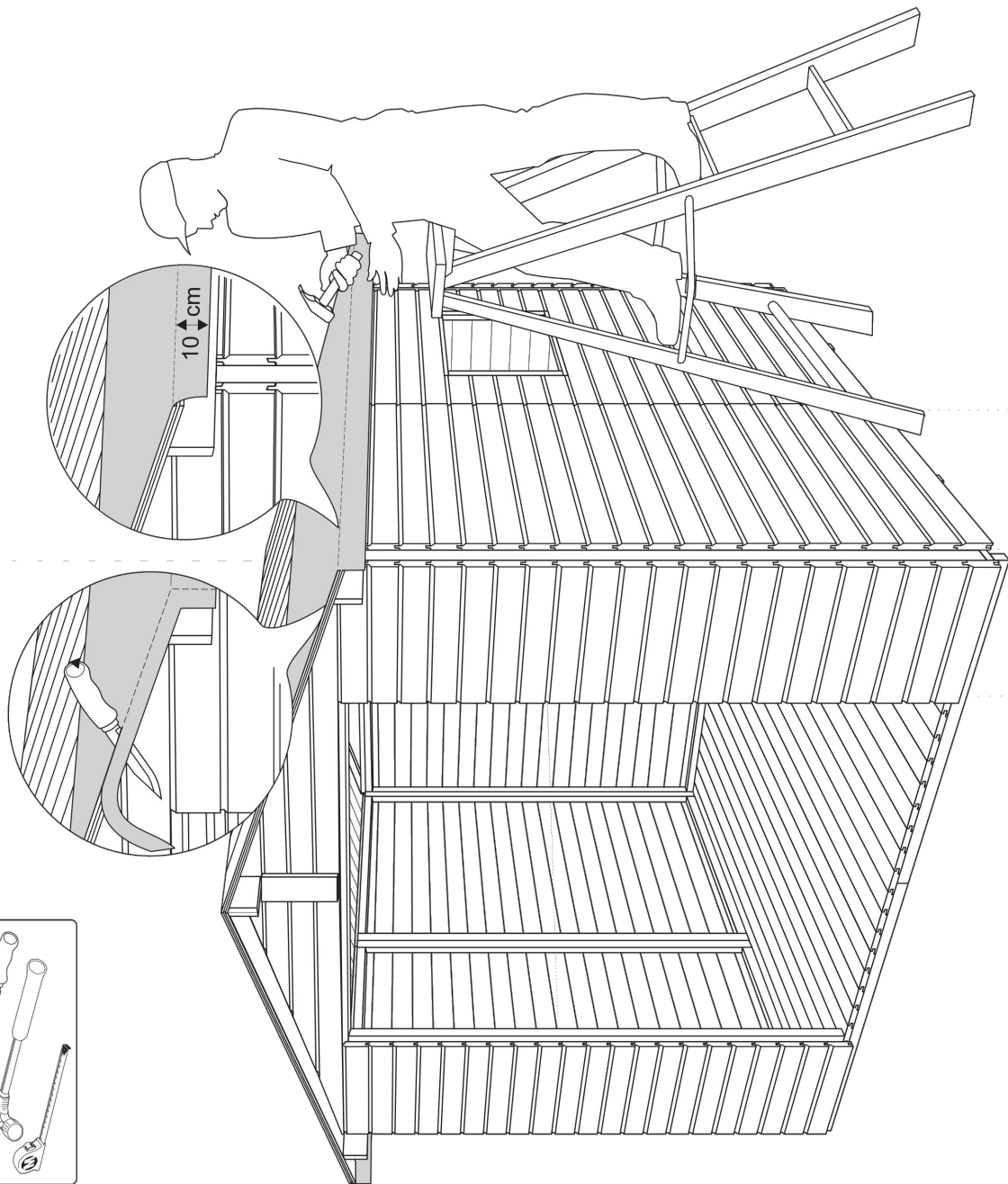
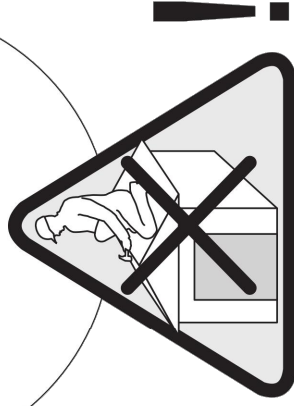
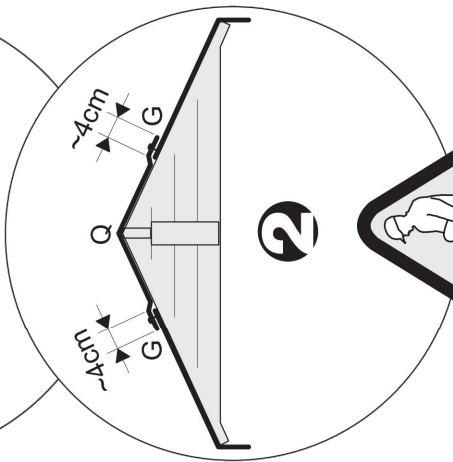
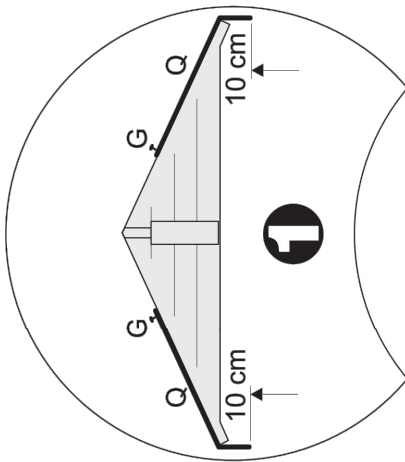
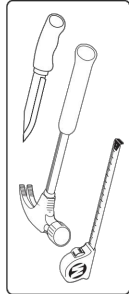

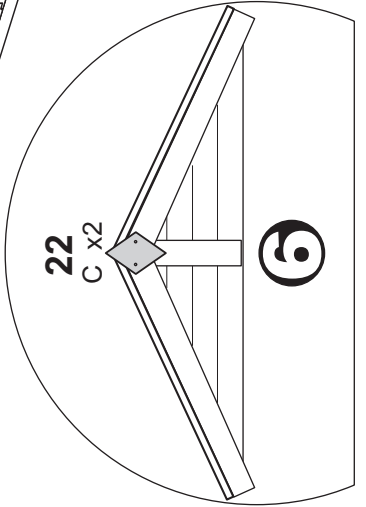
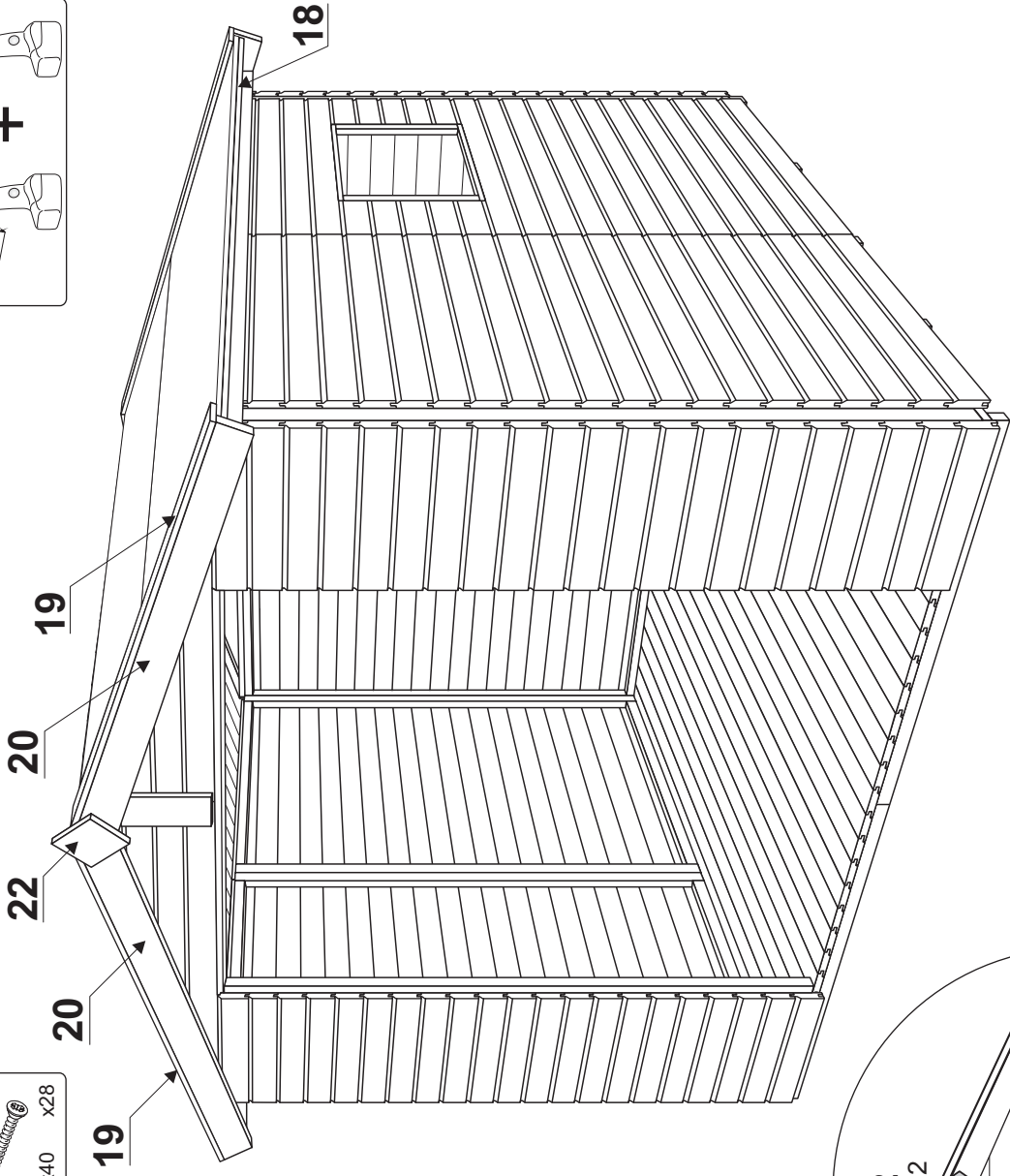
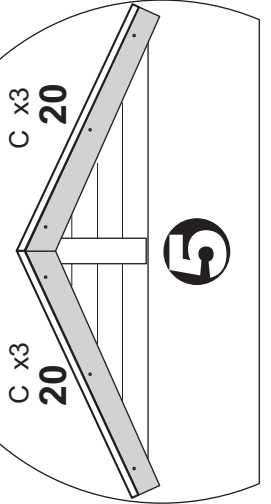
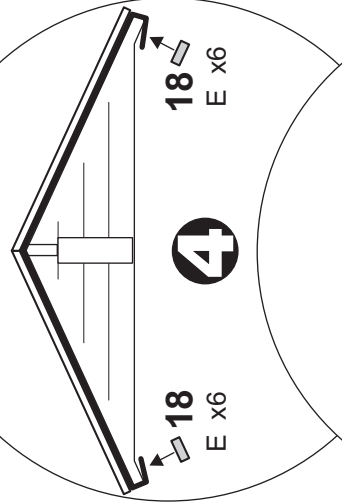
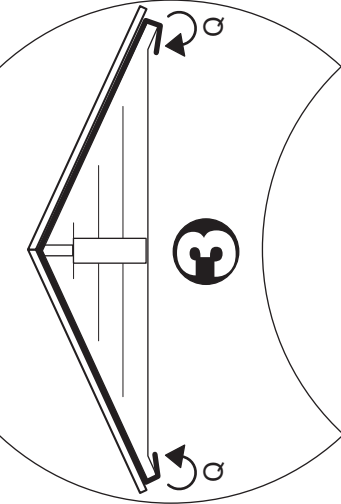
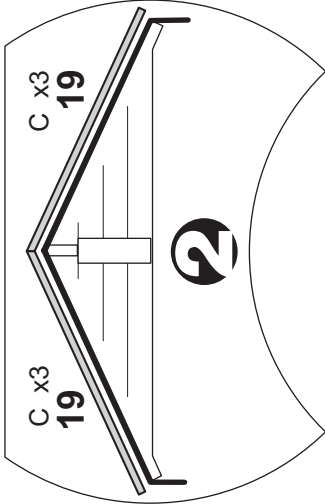
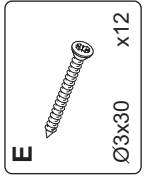
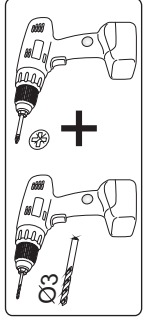

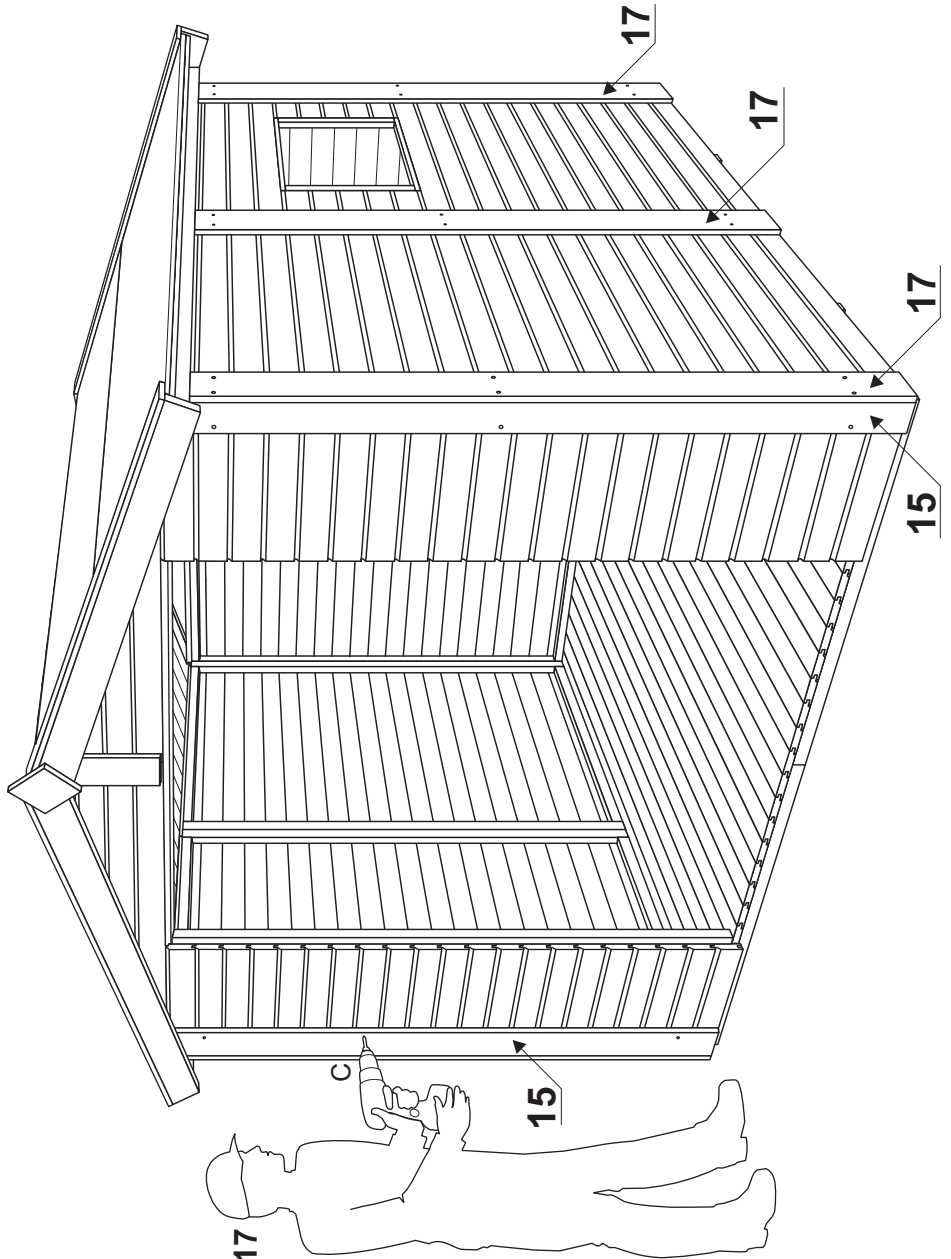
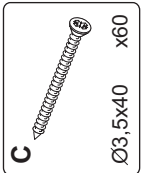
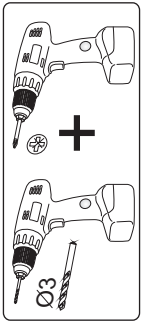
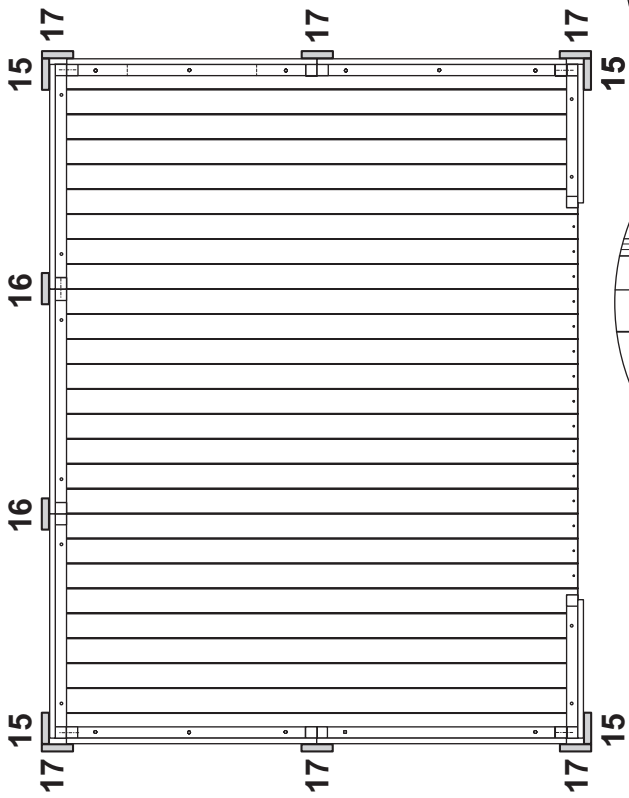

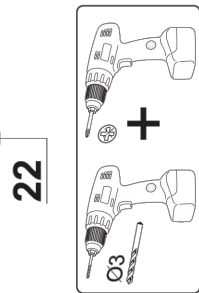
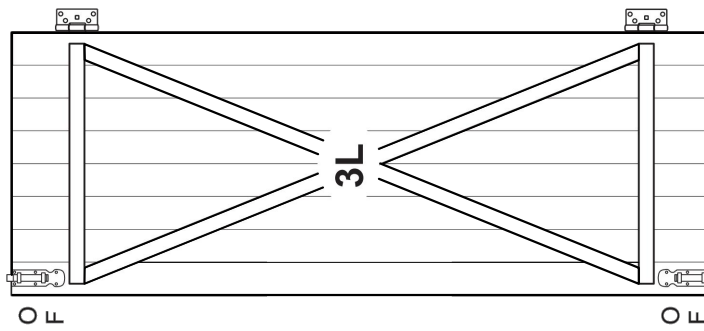
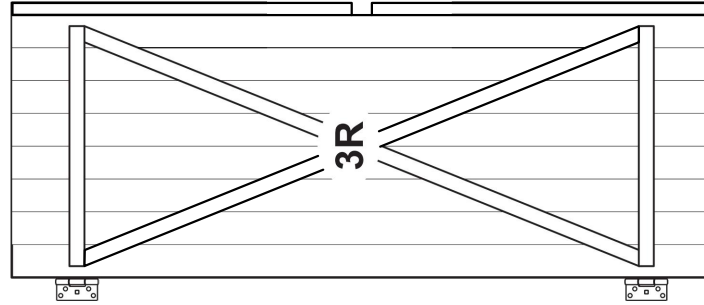
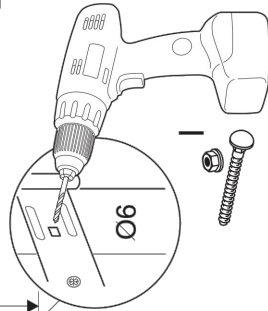
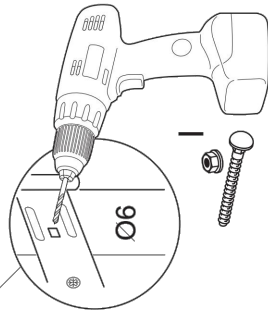
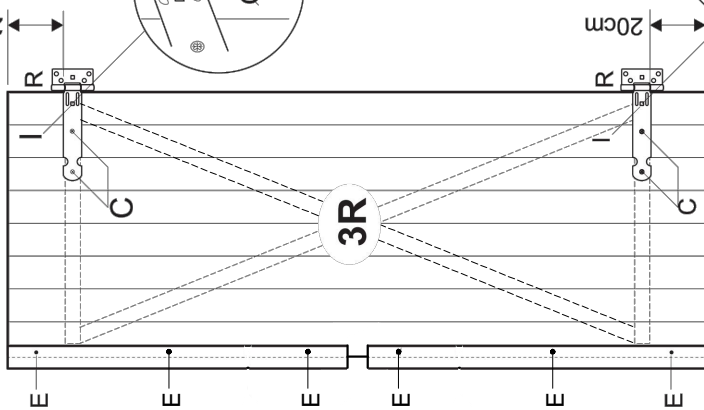
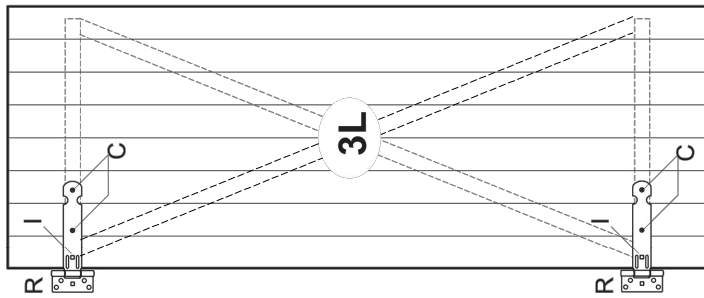
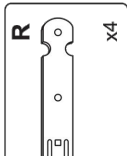
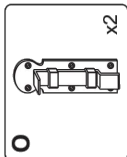
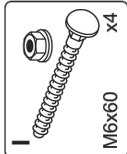
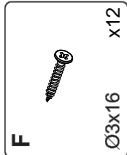
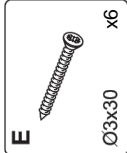

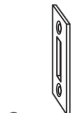
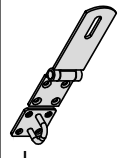

22

- C**  $\varnothing 3,5 \times 40$ x16
- I**  M6x60 x4
- F**  $\varnothing 3 \times 16$ x12
- P**  x2
- L**  x1

