

# Assembly, installation and maintenance manual

Montage-, Aufbau- und Wartungsanleitung • Assemblage, manuel de montage et d'entretien • Montaje, instalación y mantenimiento • Manuale di montaggio, installazione e manutenzione • Monterings- og vedlikeholdsmanual • Monterings-, installations- och underhållsmanual • Kokoamis-, asennus- ja huolto-ohje • Vejledning for montering og vedligehold • Handleiding voor montage, installatie en onderhoud • Manual de montagem, instalação e manutenção • Návod k montáži, instalaci a údržbě • Instrukcja montażu, instalacji i konserwacji • Surinkimo, montavimo ir priežiūros vadovas • Montāžas, uzstādīšanas un apkopes rokasgrāmata • Руководство по сборке и обслуживанию • Montaaži-, paigaldus- ja säilitamise juhend



## Element house **EL18-9045-1**

<p><b>Factory inspection by</b> • Werkskontrolle durch • Contrôle à partir de l'usine par • Inspector de fábrica • Collaudato da • Fabrikkontroll utført av • Fabriksbesiktigat av • Tehtaan tarkastaja • Fabriks Kontrol udført af • Fabrikscontrole door • Inspeção de fábrica, por: • Zkontrolováno ve výrobním závodě • Kontrola fabryczna do • Apžiūrą gamykloje atliko • Rūpnīcas pārbaudi veicis • Заводской контроль • Tehase kontroll teostatud:</p> <p>.....</p>	<p><b>Date</b> • Datum • Date • Fecha • Data • Dato • Datum • Päiväys • Dato • Datum • Data • Datum • Data • Datums • Data • Дата • Kuupäev:</p> <hr/> <p><b>Pack number</b> • Pack Nr. • Packet n° • Bulto N° • Pacco N. • Serienr • Produktionsnummer • Pakettinro • Pakke nr. • Pak nr. • Número de embalagem • Číslo balení • Numer opakowania • Pakuotės numeris • Iepakojuma numurs • Упаковочный номер • Pakinumber:</p>
--	---



[www.palmako.ee/information-hub](http://www.palmako.ee/information-hub)

**English:** Before installing and using the product, please read the instructions and warranty terms at [www.palmako.ee/information-hub](http://www.palmako.ee/information-hub) to guarantee proper installation and long-lasting performance.

**Deutsch:** Wichtig! Bitte vor Aufbau und Nutzung des Produkts unbedingt die detaillierte Montageanleitung sowie die Garantiebedingungen unter [www.palmako.ee/information-hub](http://www.palmako.ee/information-hub) lesen, um eine fachgerechte Montage und eine lange Funktionssicherheit zu gewährleisten.

**Français:** Avant d'installer et d'utiliser le produit, veuillez lire les instructions et les conditions de garantie sur [www.palmako.ee/information-hub](http://www.palmako.ee/information-hub) afin de garantir une installation correcte et la longévité du produit.

**Español:** Antes de instalar y utilizar el producto, lea las instrucciones y las condiciones de garantía en [www.palmako.ee/information-hub](http://www.palmako.ee/information-hub) para asegurar una instalación correcta y una larga vida útil del producto.

**Italiano:** Prima di installare e utilizzare il prodotto, leggere le istruzioni e le condizioni di garanzia su [www.palmako.ee/information-hub](http://www.palmako.ee/information-hub) per garantire una corretta installazione e prestazioni durature.

**Norsk:** Før montering og bruk av produktet, vennligst les monteringsanvisningene og garantivilkårene på [www.palmako.ee/information-hub](http://www.palmako.ee/information-hub) for å sikre korrekt montering og fremtidig holdbarhet.

**Svenska:** Innan du installerar och använder produkten, vänligen läs instruktionerna och garantivillkoren på [www.palmako.ee/information-hub](http://www.palmako.ee/information-hub) för att säkerställa korrekt installation och produktens långvariga hållbarhet

**Suomi:** Ennen tuotteen asentamista ja käyttämistä, lue ohjeet ja takuehdot osoitteessa [www.palmako.ee/information-hub](http://www.palmako.ee/information-hub) varmistaaksesi oikean asennuksen ja pitkäkestoisen toiminnan.

**Русский:** Перед установкой и использованием изделия ознакомьтесь с инструкцией и условиями гарантии на сайте [www.palmako.ee/information-hub](http://www.palmako.ee/information-hub), чтобы гарантировать правильную установку и долговечность изделия.

**Eesti:** Enne toote paigaldamist ja kasutuselevõttu lugege palun juhiseid ja garantiitingimusi aadressil [www.palmako.ee/information-hub](http://www.palmako.ee/information-hub), et tagada nõuetekohane paigaldus ja toote pikk eluiga.

**Dansk (Oversat af AI):** Læs venligst instruktionerne og garantibetingelserne på [www.palmako.ee/information-hub](http://www.palmako.ee/information-hub), før du installerer og bruger produktet, for at garantere korrekt installation og langvarig ydeevne.

**Dutch (Vertaald door AI):** Lees vóór de installatie en het gebruik van het product de instructies en garantievoorwaarden op [www.palmako.ee/information-hub](http://www.palmako.ee/information-hub) om een correcte installatie en langdurige werking te garanderen

**Português (Traduzido por IA):** Antes de instalar e utilizar o produto, leia as instruções e os termos de garantia em [www.palmako.ee/information-hub](http://www.palmako.ee/information-hub) para garantir uma instalação adequada e um desempenho duradouro.

**Čeština (Přeloženo umělou inteligencí):** Před instalací a použitím produktu si prosím přečtěte pokyny a záruční podmínky na [www.palmako.ee/information-hub](http://www.palmako.ee/information-hub), abyste zaručili správnou instalaci a dlouhodobý výkon.

**Polski (Przetłumaczone przez AI):** Przed zainstalowaniem i użyciem produktu należy przeczytać instrukcję oraz warunki gwarancji dostępne na stronie [www.palmako.ee/information-hub](http://www.palmako.ee/information-hub), co pozwoli zagwarantować prawidłową instalację i długotrwałą wydajność.

**Latviešu (Mākslīgā intelekta tulkojums):** Pirms produkta uzstādīšanas un lietošanas, lūdzu, izlasiet instrukcijas un garantijas noteikumus vietnē [www.palmako.ee/information-hub](http://www.palmako.ee/information-hub), lai garantētu pareizu uzstādīšanu un ilgstošu darbību.

**Lietuviškai (Išvertė DI):** Prieš montuodami ir naudodami gaminį, perskaitykite instrukcijas ir garantijos sąlygas adresu [www.palmako.ee/information-hub](http://www.palmako.ee/information-hub), kad užtikrintumėte tinkamą montavimą ir ilgalaikį veikimą.

901

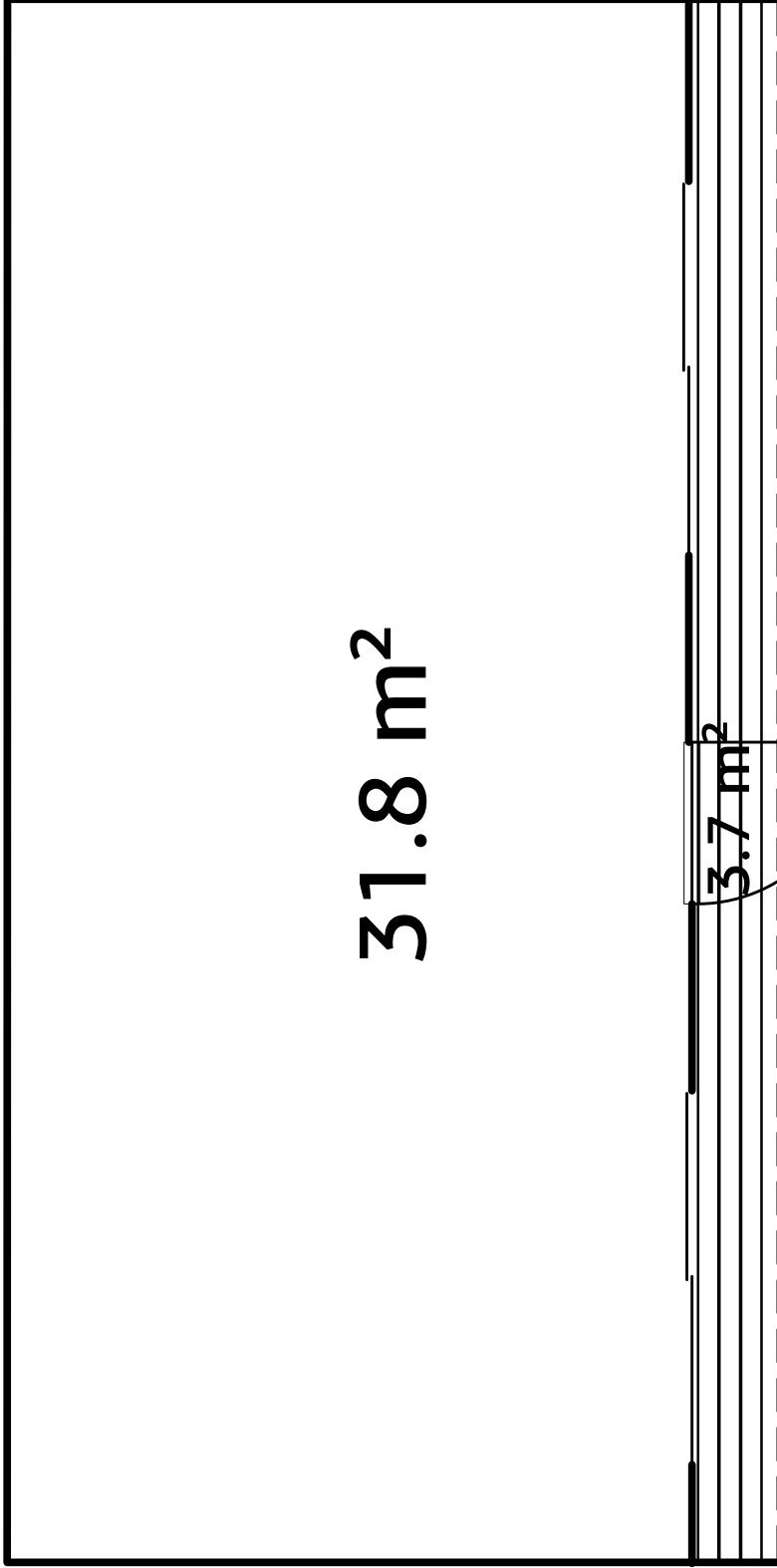

448





398



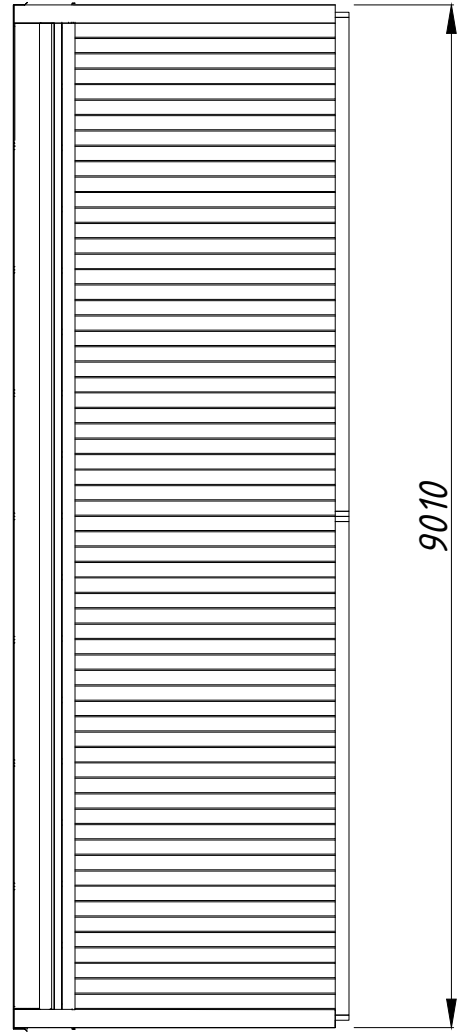
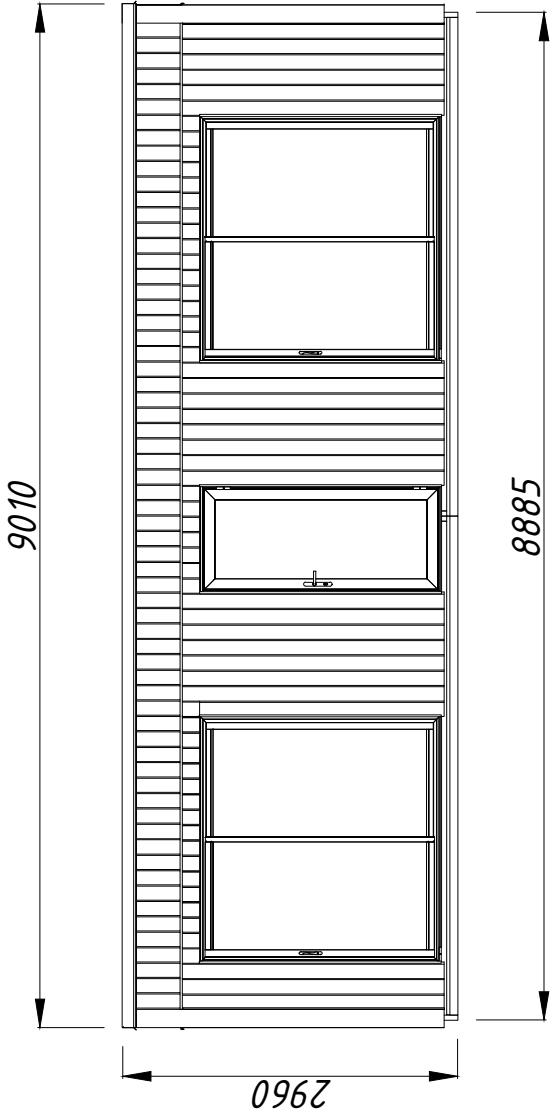
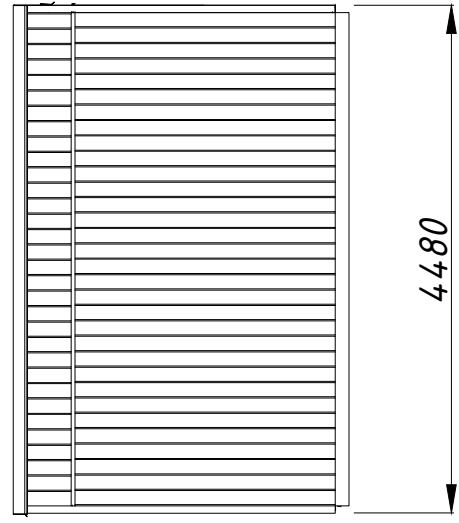
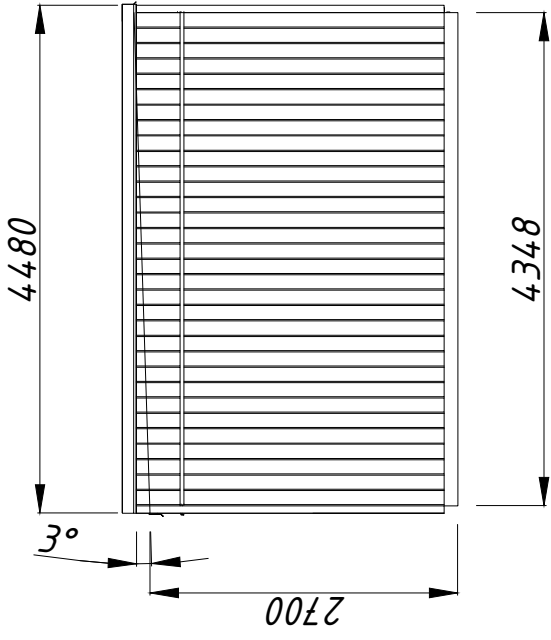

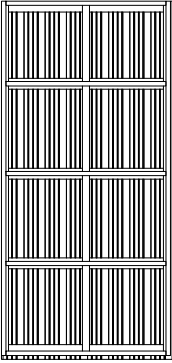
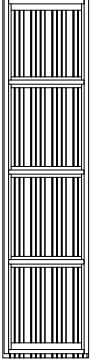
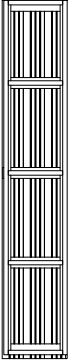

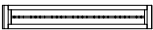

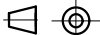

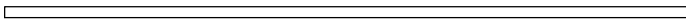
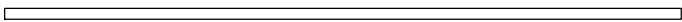





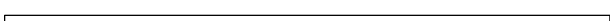



31.8 m<sup>2</sup>

3.7 m<sup>2</sup>











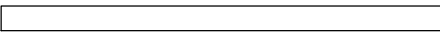

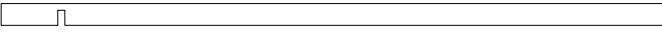

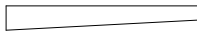
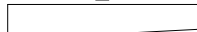
901

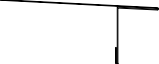
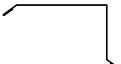

Pos	SPECIFICATION-STÜCKLISTE-NOMENCLATURE-ELEMENTI-ESPECIFICACIÓN EL18-5634-1-1	Pcs	Profile (mm)	Length (mm)
EL1		10	1087X160	2280
EL2		1	543X160	2280
EL3		2	407X160	2280
EL4		1	150X160	2175
EL5		1	150X160	950
EL-Door		1	137X160	2280
	Object name EL18-5634-1-1			Page 1/1

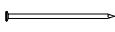
Pos	SPECIFICATION-STÜCKLISTE-NOMENCLATURE-ELEMENTI-ESPECIFICACIÓN EL18-9045-1-2	Pcs	Profile (mm)	Length (mm)
AR1	Foundation- Fundament- Fondation- Fondazione- Vigas de cimentación 	4	45x70	4397
AR2	Foundation- Fundament- Fondation- Fondazione- Vigas de cimentación 	24	45x145	4352
AR3	Foundation- Fundament- Fondation- Fondazione- Vigas de cimentación 	2	45x145	4348
AR4	Foundation- Fundament- Fondation- Fondazione- Vigas de cimentación 	20	45x70	406
AR5	Foundation- Fundament- Fondation- Fondazione- Vigas de cimentación 	2	45x145	3852
BM1	Beam- Balken- Poutre- Trave- Viga 	1	44x140	4695
BM2	Beam- Balken- Poutre- Trave- Viga 	1	44x140	4800
Sla1		2	45x45	3895
Sla2	Slat- Leiste- Baguette- Listello- Listón 	2	45x45	4800
Sla3	Slat- Leiste- Baguette- Listello- Listón 	1	95x44	3924
Sla4	Slat- Leiste- Baguette- Listello- Listón 	1	95x44	4961
Sla5	Slat- Leiste- Baguette- Listello- Listón 	2	95x44	4253
FB2-1	Floor board- Fussbodenbrett- Madrier du plancher - Tavola pavimento- Tabla de suelo 	98	89x19	3656
TB2-1	Terrace board- Terrassenbrett- Madrier de terrasse- Tavola terrazzo- Tabla de terraza 	5	120x28	4892
TB2-2	Terrace board- Terrassenbrett- Madrier de terrasse- Tavola terrazzo- Tabla de terraza 	5	120x28	3891
FB5-1	Ceiling board- Dachbodenbrett- Madrier du Grenier- Tavola soffitta- Tabla de techo 	9	95x19	4888
FB5-2	Ceiling board- Dachbodenbrett- Madrier du Grenier- Tavola soffitta- Tabla de techo 	9	95x19	3807
FB5-5	Ceiling board- Dachbodenbrett- Madrier du Grenier- Tavola soffitta- Tabla de techo 	10	95x19	2312
ELEL1	ELEMENDI LAUD 	6	28x95	550
ELEL2	ELEMENDI LAUD 	2	28x95	490
ELEL3	ELEMENDI LAUD 	18	25x45	1031
ELEL4	ELEMENDI LAUD 	3	25x45	351

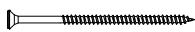
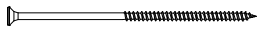
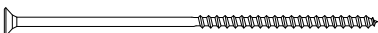
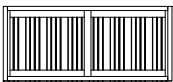

Pos	SPECIFICATION-STÜCKLISTE-NOMENCLATURE-ELEMENTI-ESPECIFICACIÓN EL18-9045-1-3	Pcs	Profile (mm)	Length (mm)
Pst1	Post- Pfosten- Poteau- Montante- Poste 	4	65x160	2829
RoR1	Rafter- Sparre- Chevron- Trave- Cabrio 	17	140x44	154
RoR2	Rafter- Sparre- Chevron- Trave- Cabrio 	17	140x44	86
RoR3	Rafter- Sparre- Chevron- Trave- Cabrio 	17	140x44	4256
RoR4	Rafter- Sparre- Chevron- Trave- Cabrio 	17	140x44	4266
OSB_1	OSB_15mm 	2	1250x15	92
OSB_2	OSB_15mm 	2	1250x15	158
OSB_3	OSB_15mm 	2	1250x15	224
RB2-1	Roof board- Dachbrett- Madrier du toit- Tavola tetto- Tabla de tejado 2 	51	89x19	4888
RB2-2	Roof board- Dachbrett- Madrier du toit- Tavola tetto- Tabla de tejado 2 	51	89x19	3807
Sla1	Slat- Leiste- Baguette- Listello- Listón 	2	95x44	4889
Sla2	Slat- Leiste- Baguette- Listello- Listón 	2	95x44	3807
WG10-1	Water gutter- Wasserleiste- Rejet d'eau- Protección de lluvia- Protezione dalla pioggia- QP201x81x...HA 	4		2380
WG7-1	Water gutter- Wasserleiste- Rejet d'eau- Protección de lluvia- Protezione dalla pioggia- QP216x120x...HA 	4		2500
WG7-2	Water gutter- Wasserleiste- Rejet d'eau- Protección de lluvia- Protezione dalla pioggia- QP216x120x...HA 	4		2480
QNA2 2x50Zn	Nail- Nagel- Clou- Chiodo- Clavo- 2.5x50mm 	1200	FB2-1	
QNA3 x70Zn	Nail- Nagel- Clou- Chiodo- Clavo- 3x70mm 	1000	RB2-1 - 2	
QKRPP4 _5x60Zn	Screw- Schraube- Vis- Vite- Tornillo- 4.5x60mm 	760	OSB_1, 2, 3 EL9, 10, 11 EL1+EL2+EL3	
QKRK K4 8 x28MU	Screw- Schraube- Vis- Vite- Tornillo- 4.8x28mm MU 	100		
QKRPP5 x80ZnTX	Screw- Schraube- Vis- Vite- Tornillo- 5x80mm 	550	EL9, 10, 11 EL1, EL2, EL3+ EL1, EL2, EL3+	Pst1 AR1, 2... Sla3, 4, 5
QKRP P6x1 20ZnTX	Screw- Schraube- Vis- Vite- Tornillo- 6x120mm TX 	100	RoR1, 2, 3, 4 BM1 BM2	
QKRPP 6x160 ZnTX-1	Screw- Schraube- Vis- Vite- Tornillo- 6x160mm TX-1 	250	RoR1, 2, 3, 4 AR1, 2, 3...	
QKRPP 8x240 kZnTX	Screw- Schraube- Vis- Vite- Tornillo- 8x240mm 	155	RoR1, 2, 3, 4	
EL9		16	1087X480	

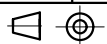



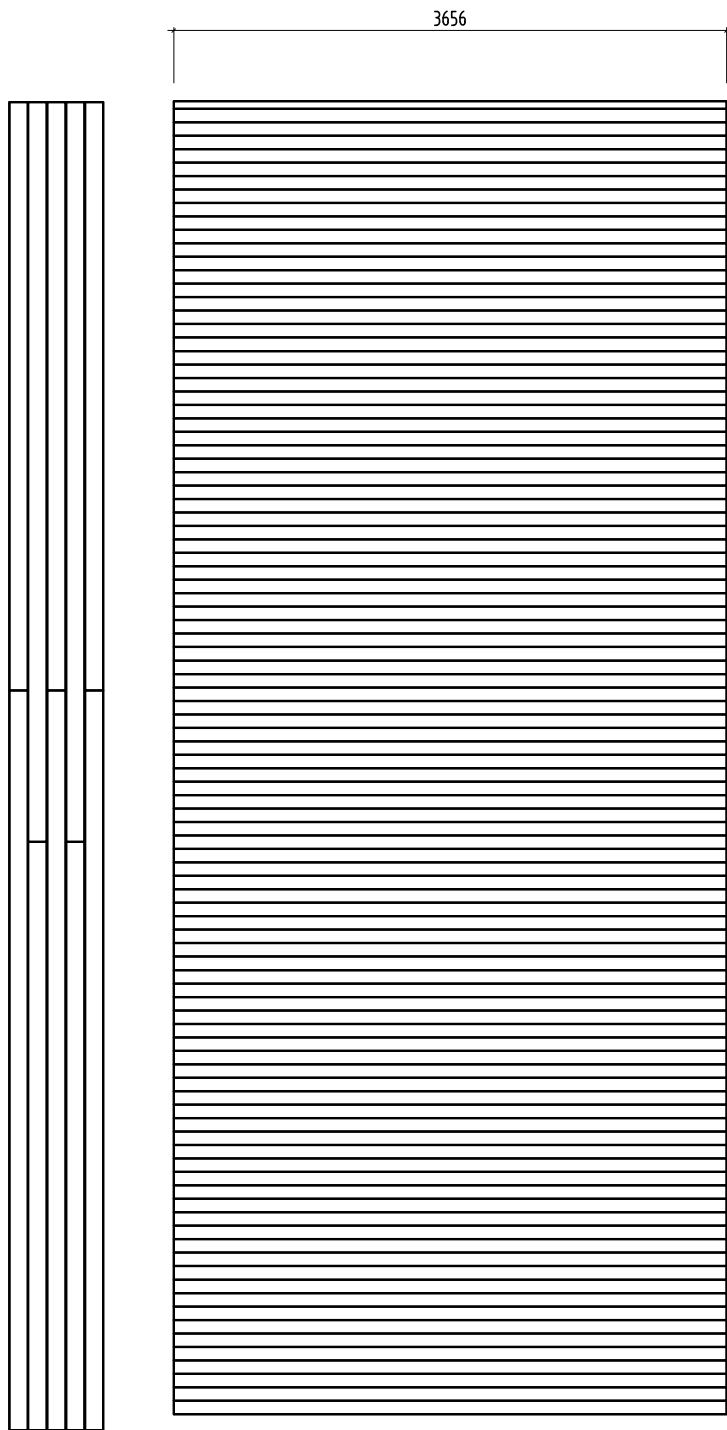

Floor + Terrace boards

Lath 44x95 on top of the bottom wall panels

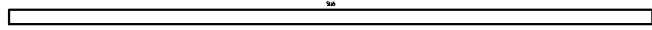

EL1 EL1 EL1 EL1

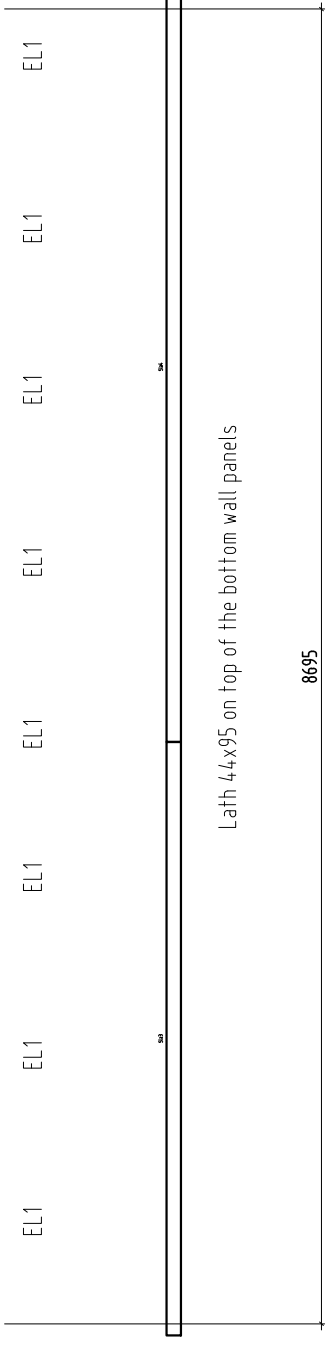
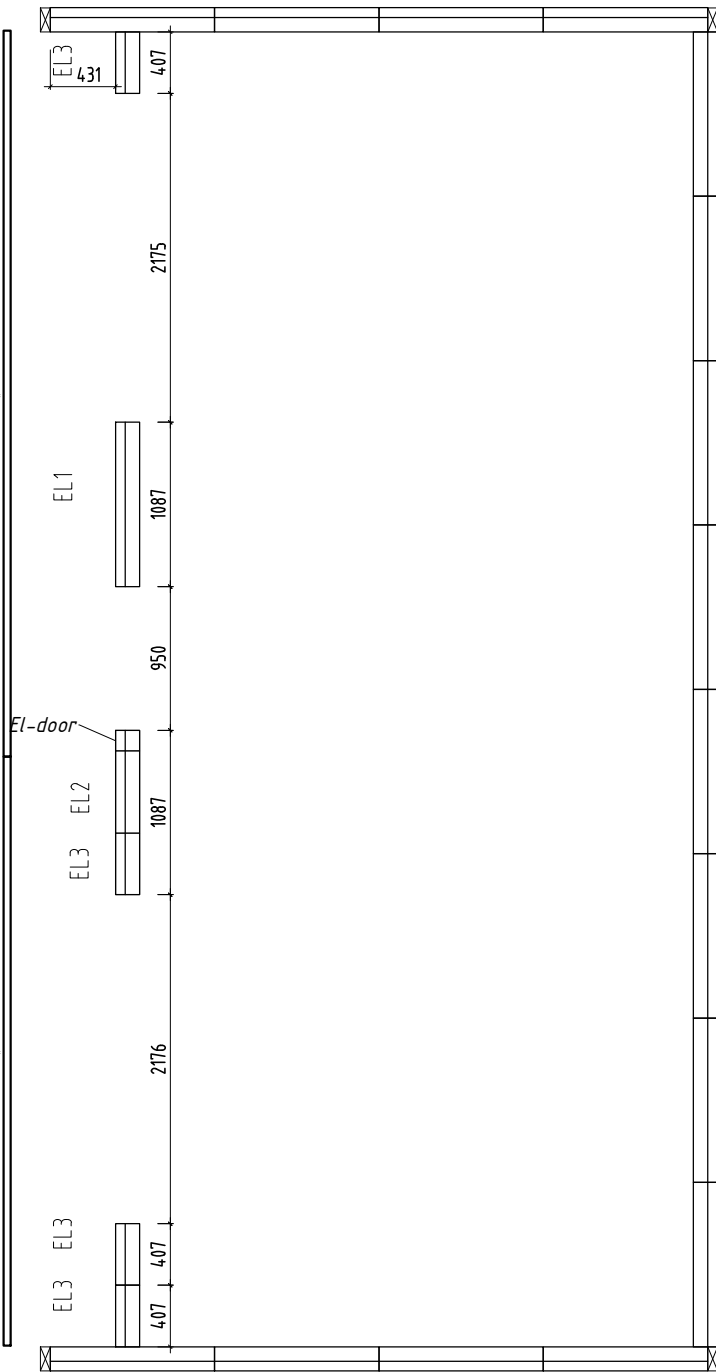
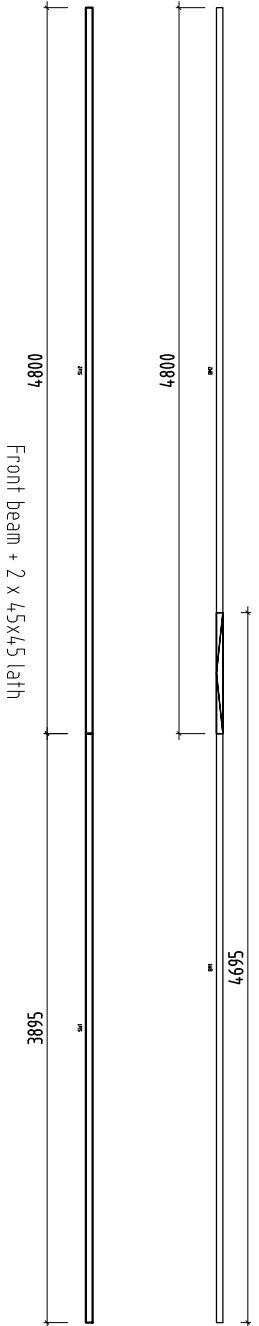

Lath 44x95 on top of the bottom wall panels

8695

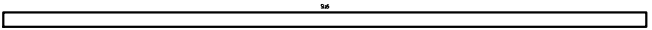

Lath 44x95 on top of the bottom wall panels

EL1 EL1 EL1 EL1

**NB!**

1.

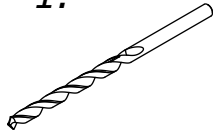

2.

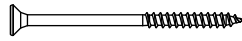

$\varnothing 1,5 \text{ mm}$	$\varnothing 3,0...4$
$\varnothing 2,0 \text{ mm}$	$\varnothing 4,5$
$\varnothing 3,0 \text{ mm}$	$\varnothing 5,0$

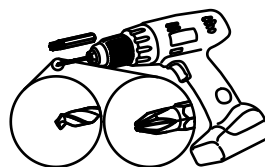
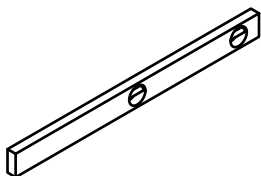
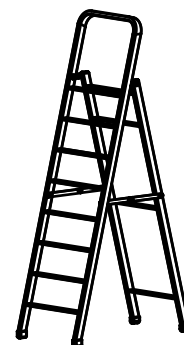
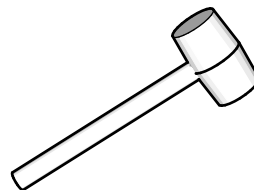
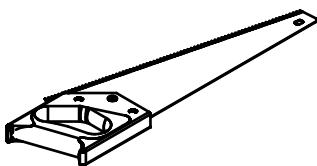
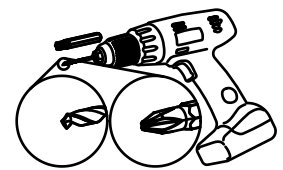
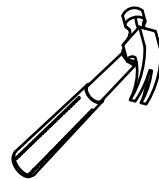
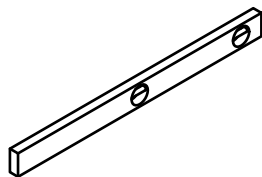
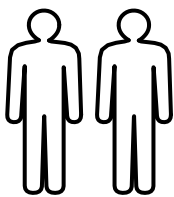
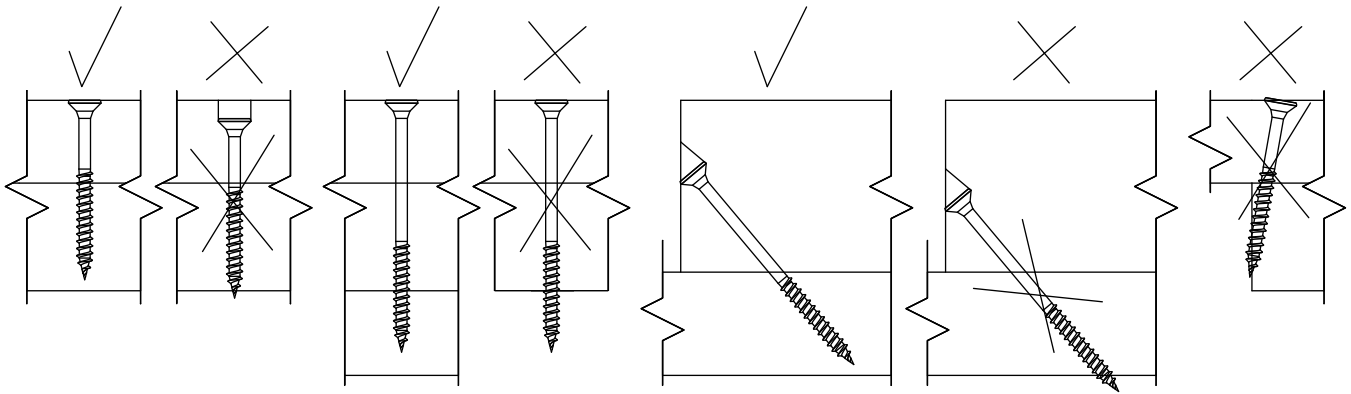

**\***

ENG	-	Not included
GER	-	Nicht enthalten
FR	-	Non inclus
ES	-	No incluso
IT	-	Non incluso
NO	-	Ikke inkludert
SWE	-	Ingår inte
FIN	-	Ei sisälly hintaan
DEN	-	Ikke inkluderet
NED	-	Niet inbegrepen
POR	-	Não incluído
CZ	-	Není zahrnuto
POL	-	Nie wliczone
LIT	-	Neįtraukta
LAT	-	Nav iekļauts
RUS	-	Не включено
EST	-	Ei sisaldu komplektis

**\*\***

ENG	-	Separate manual
GER	-	Separates Handbuch
FR	-	Manuel séparé
ES	-	Manual separado
IT	-	Manuale separato
NO	-	Separat manual
SWE	-	Separat manual
FIN	-	Erillinen käyttöohje
DEN	-	Separat manual
NED	-	Aparte handleiding
POR	-	Manual separado
CZ	-	Samostatný manuál
POL	-	Osobna instrukcja
LIT	-	Atskiras vadovas
LAT	-	Atsevišķa rokasgrāmata
RUS	-	Отдельное руководство
EST	-	Eraldi juhend

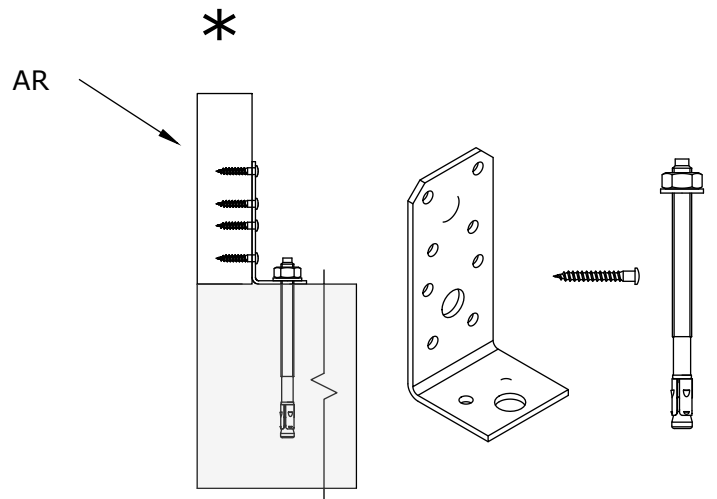
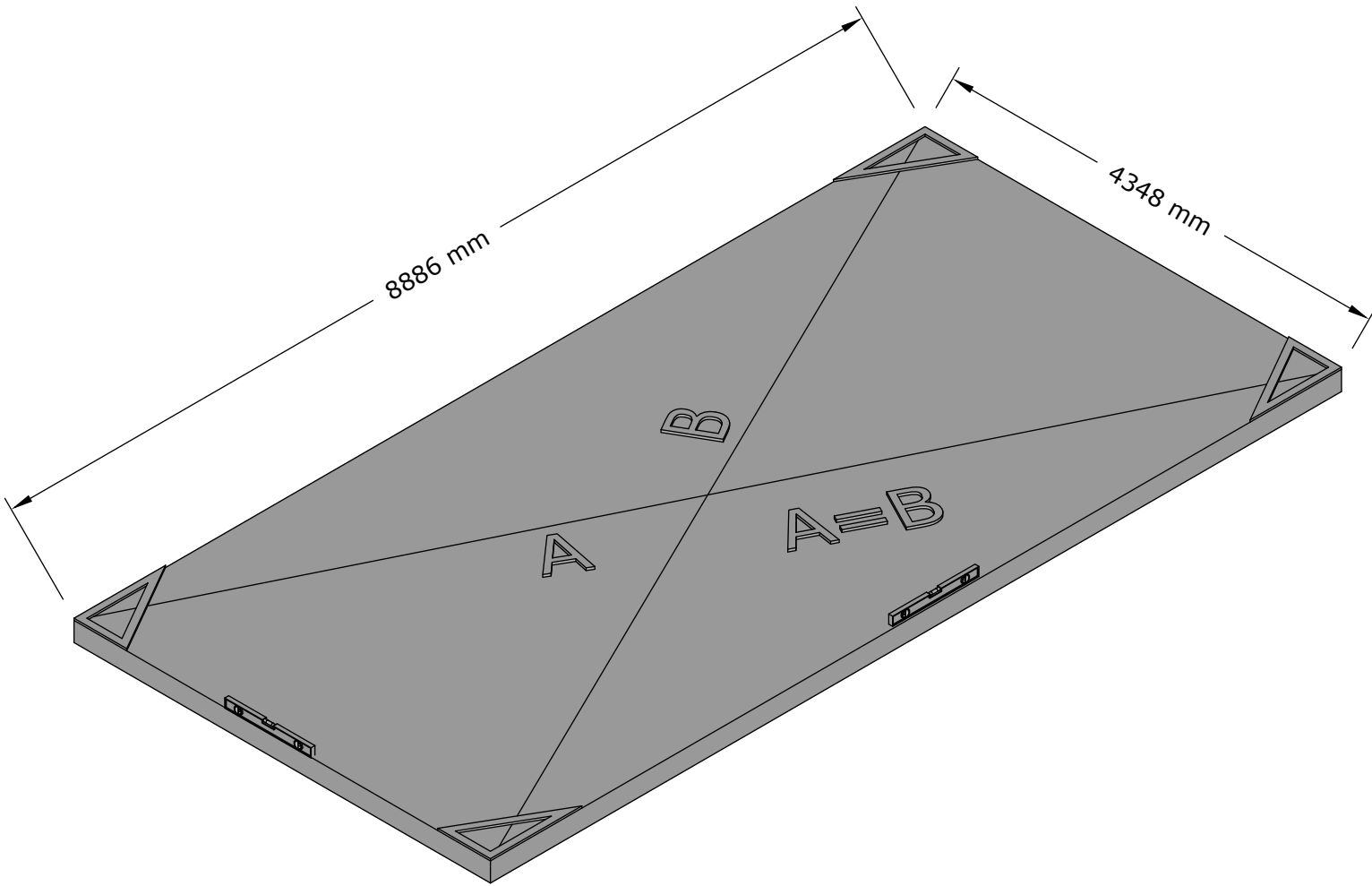
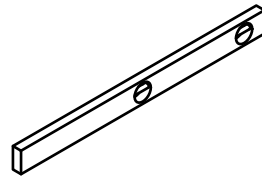

- AR1 x4
- AR2 x24
- AR3 x2
- AR4 x20
- AR5 x2

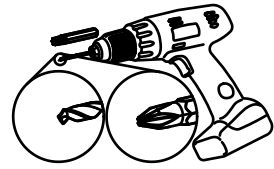
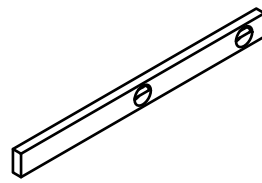

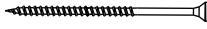
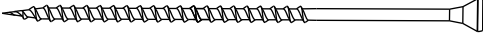
- Ø5x80 x60 
- Ø6x160 x144 

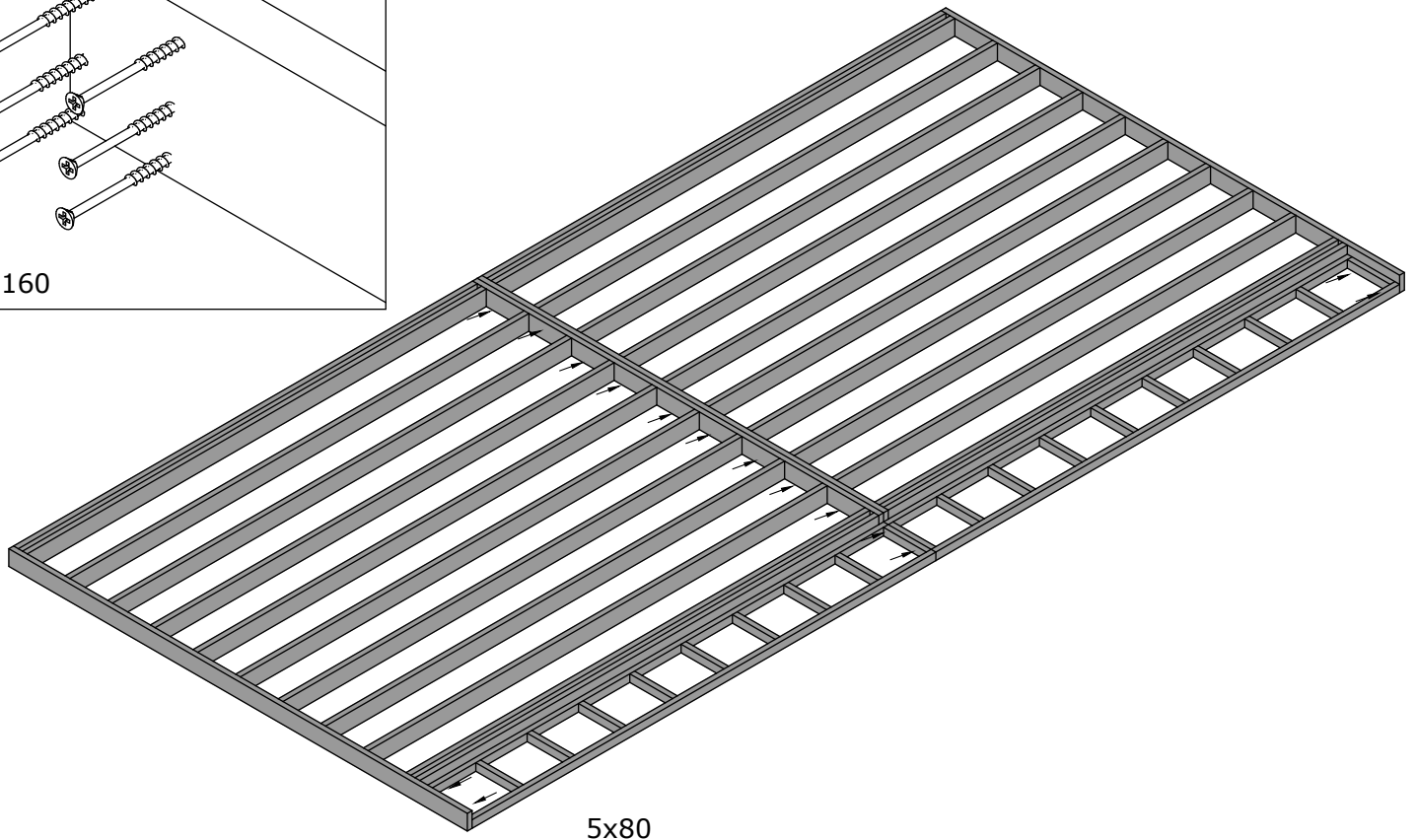
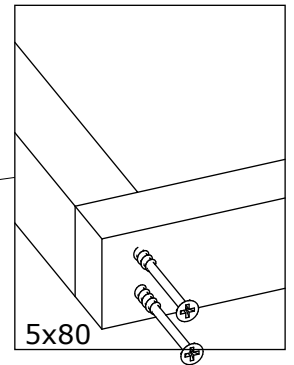
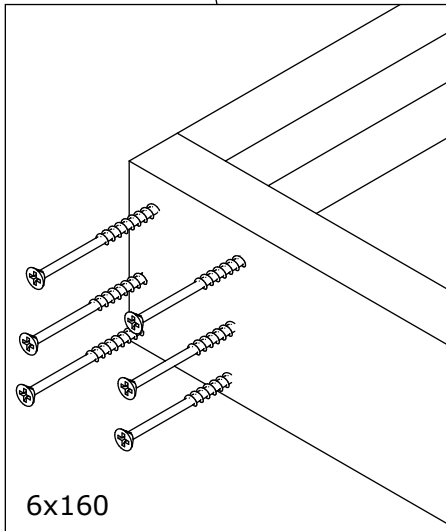
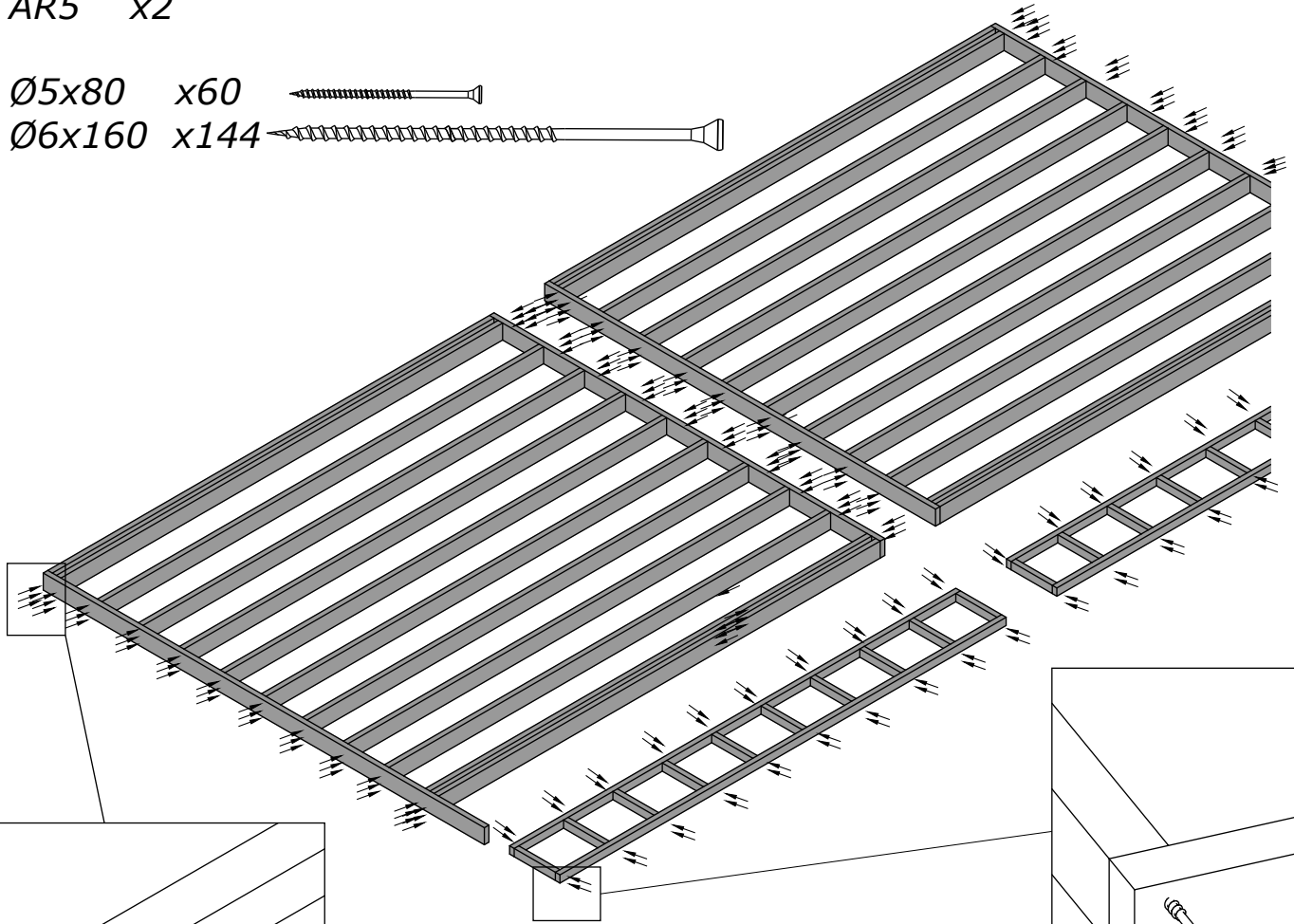

- AR1 x4
- AR2 x24
- AR3 x2
- AR4 x20
- AR5 x2

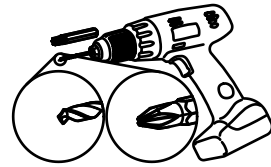
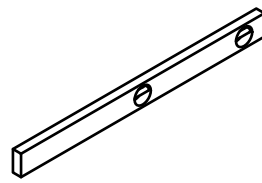

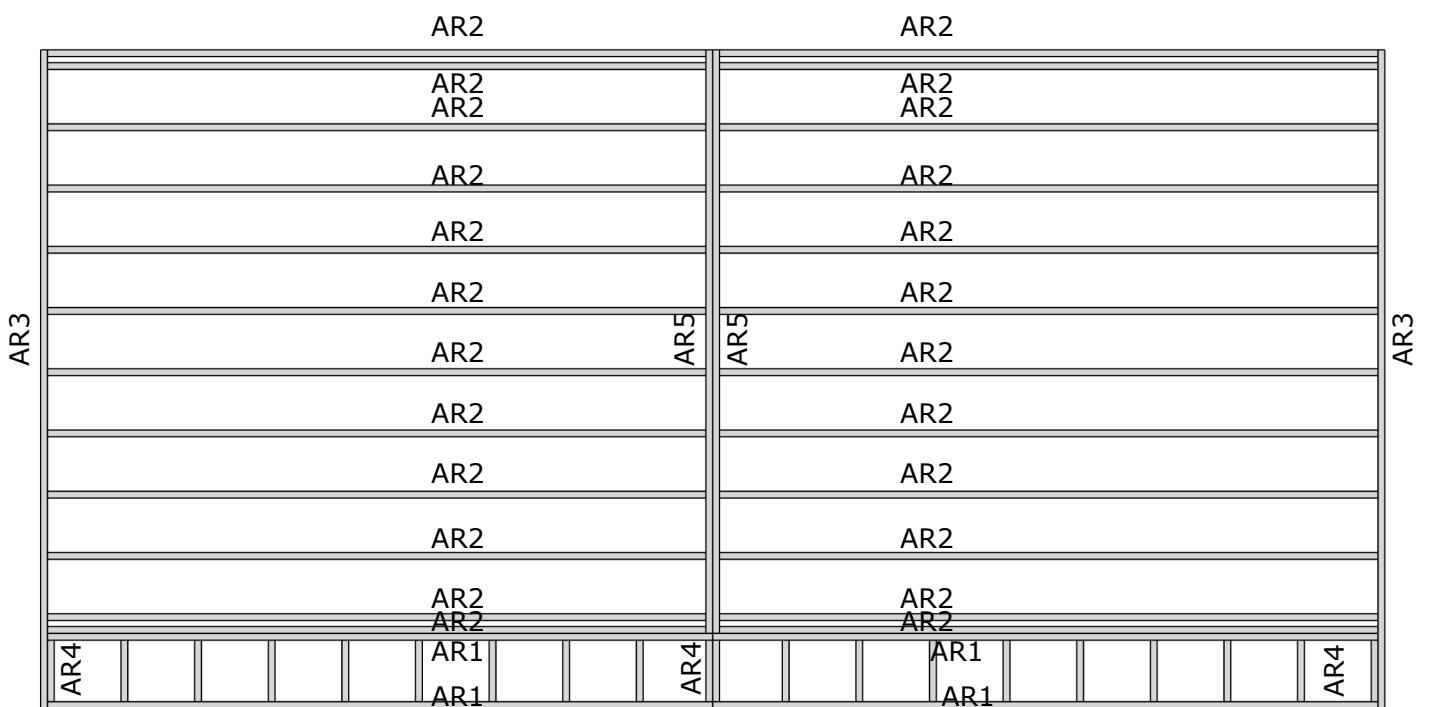
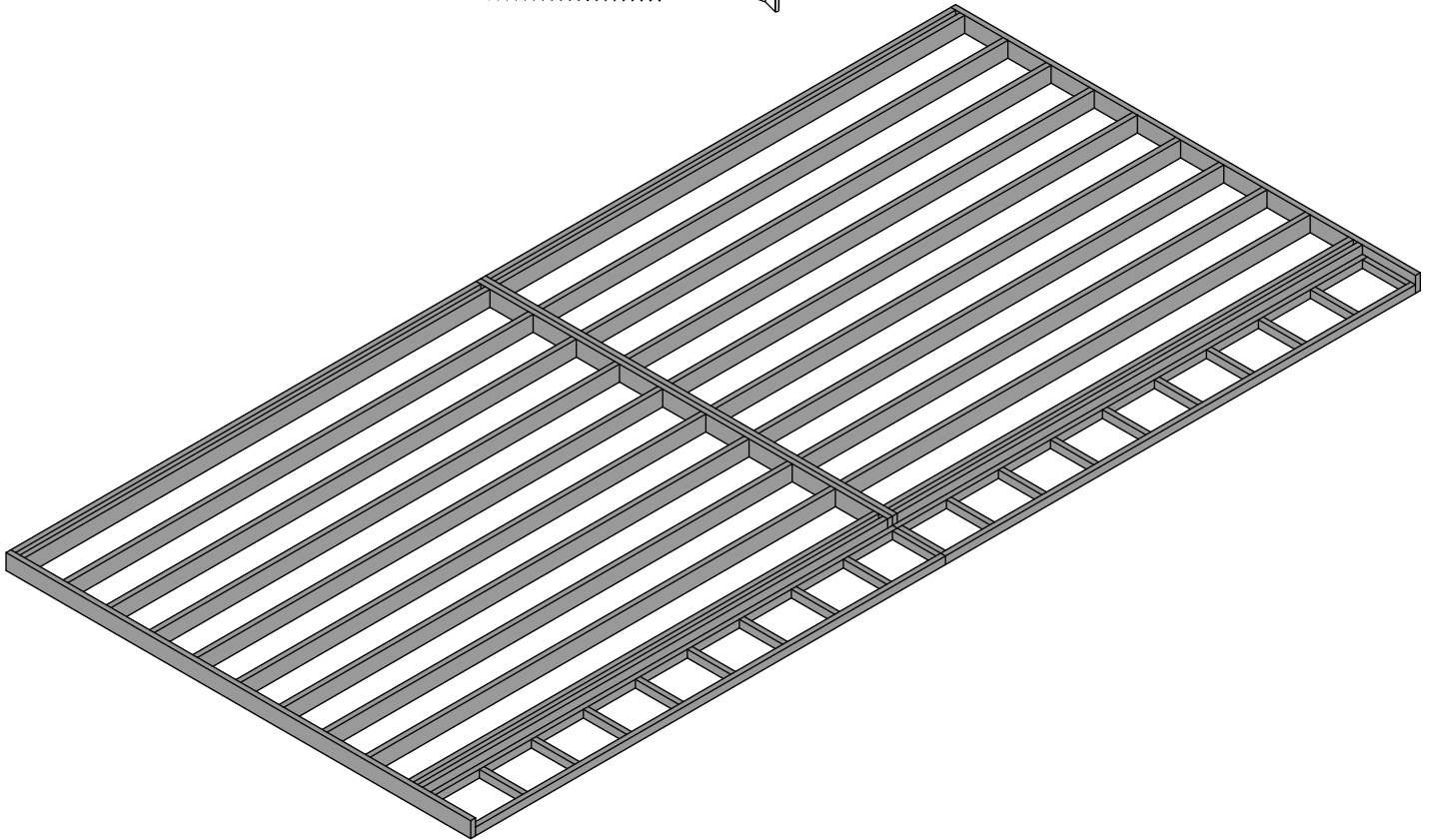
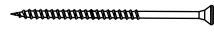

- Ø5x80 x60
- Ø6x160 x144

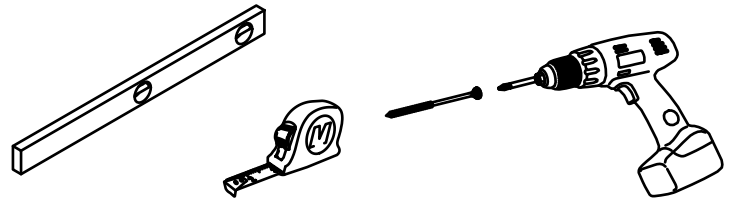

- E1 x18
- E3 x3
- E4 x2
- E5 x1

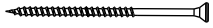

- Ø4,5x60 x96 
- Ø5x80 x72 

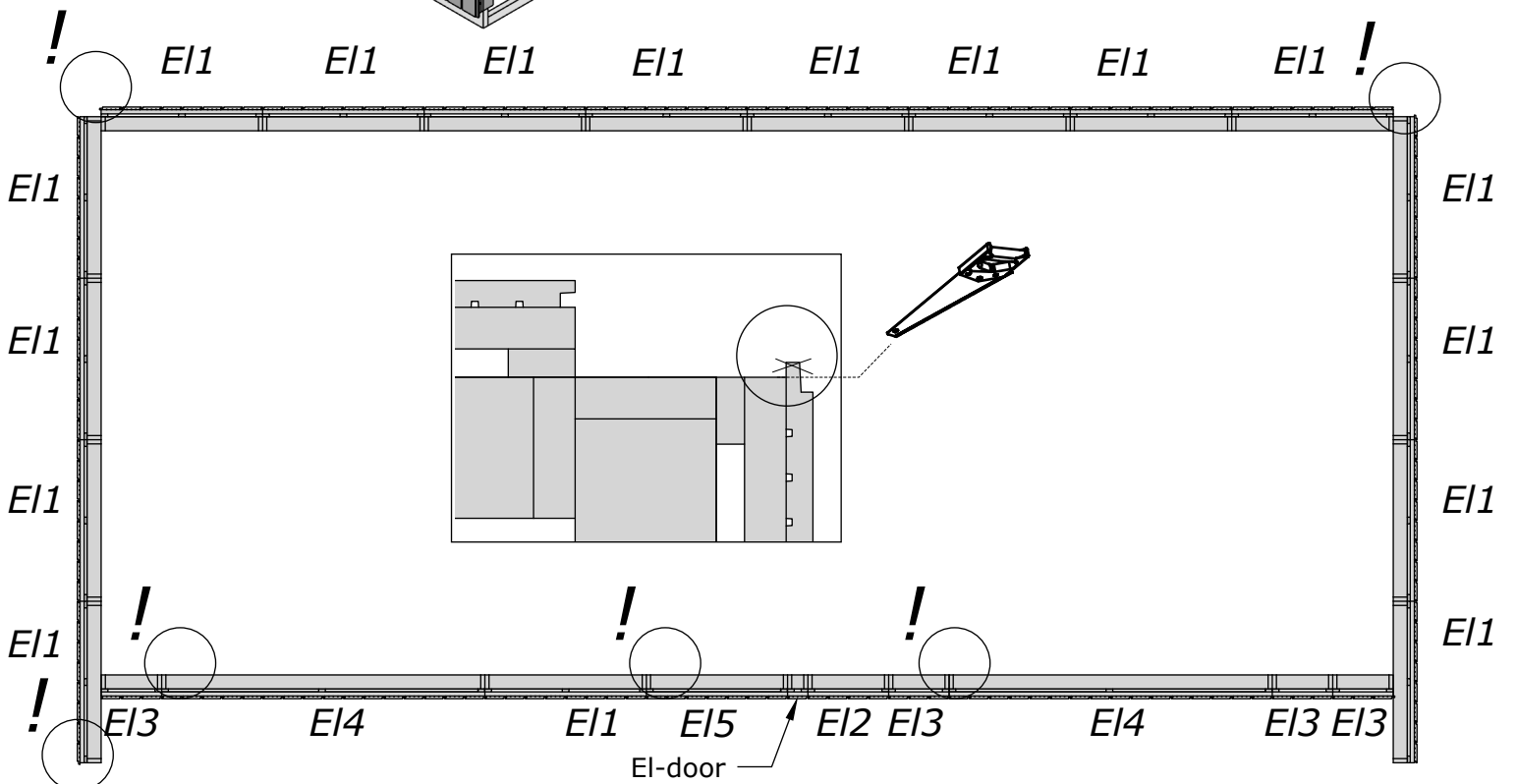
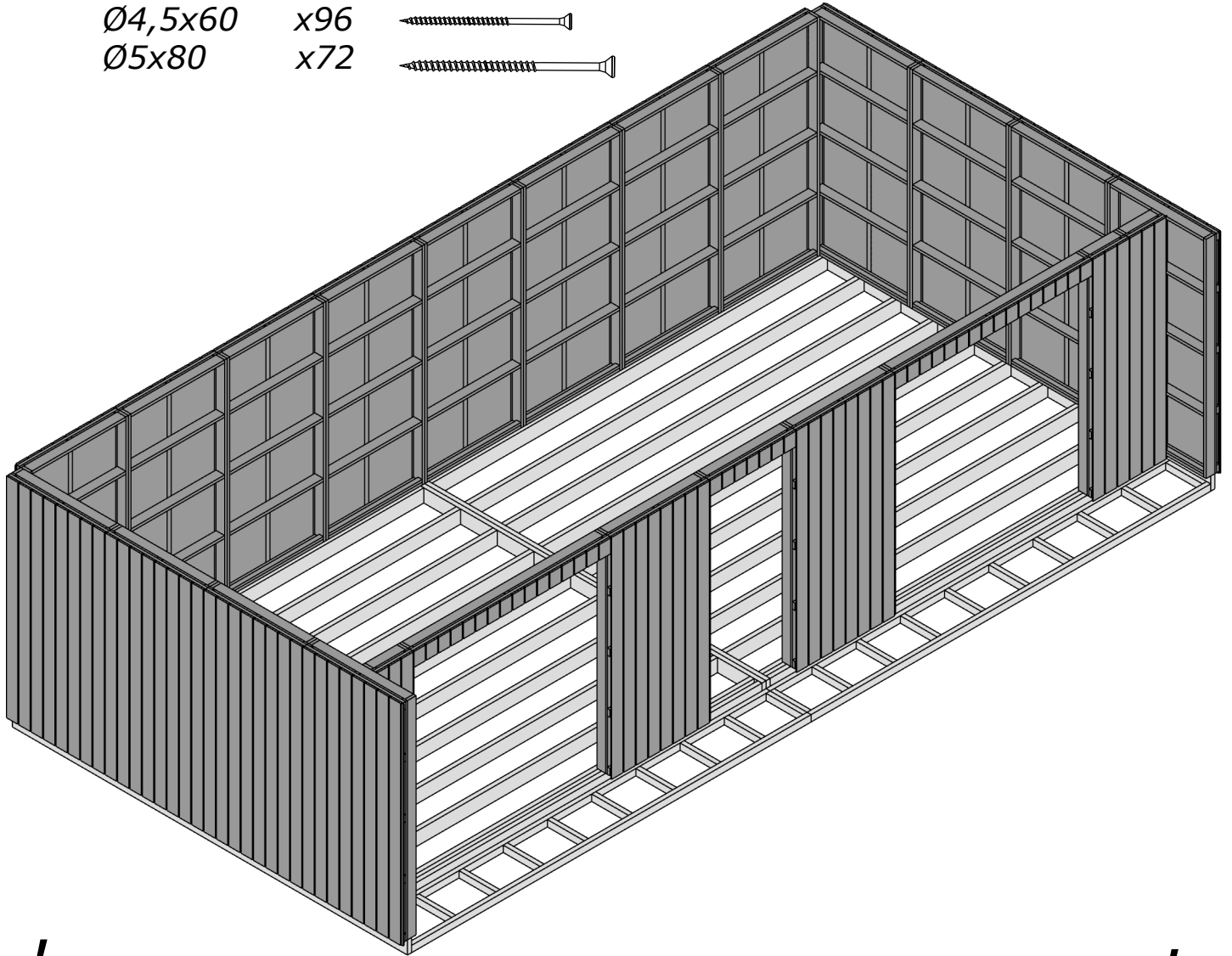

- E11 x12
- E12 x3
- E13 x1
- E14 x1
- E15 x1

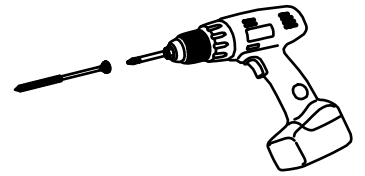
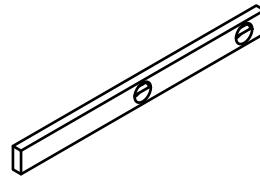

- Ø4,5x60 x96
- Ø5x80 x72

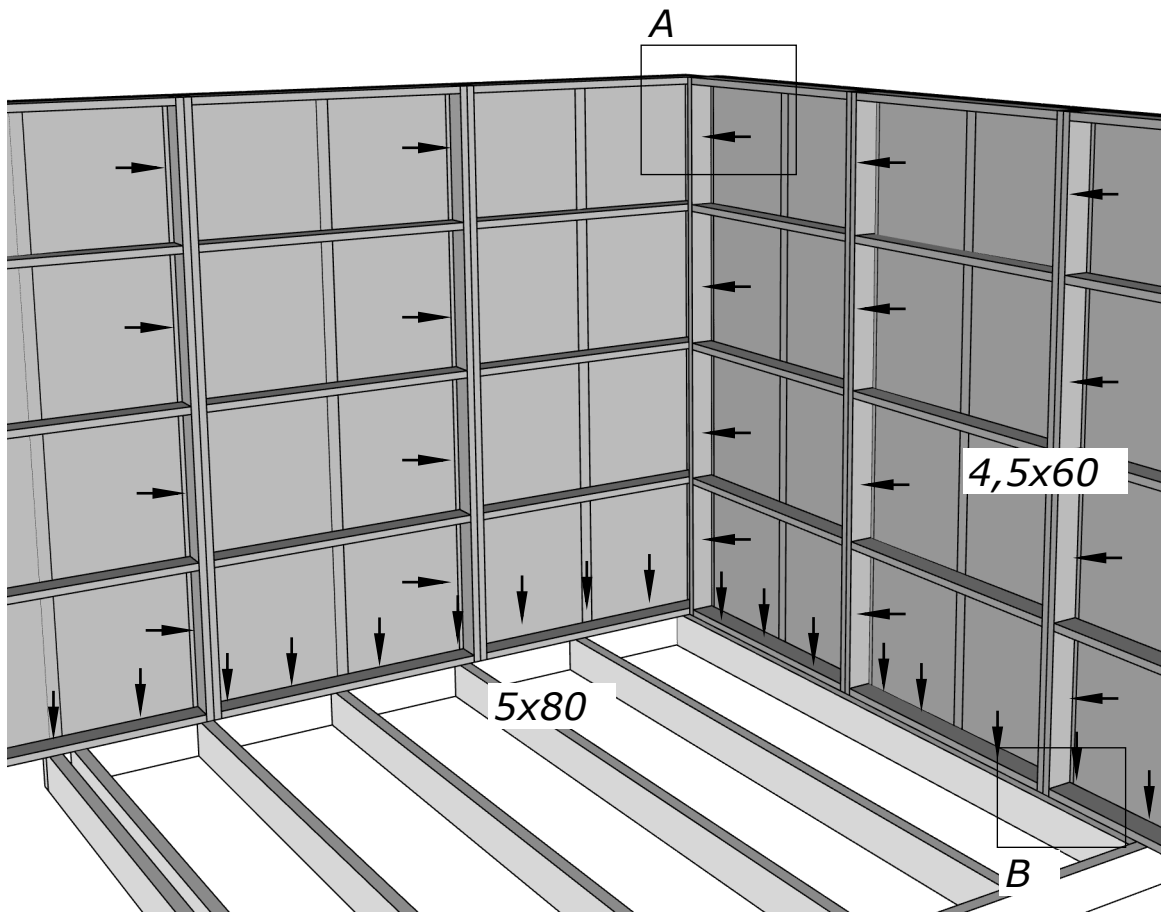
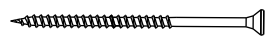
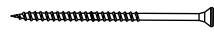

A

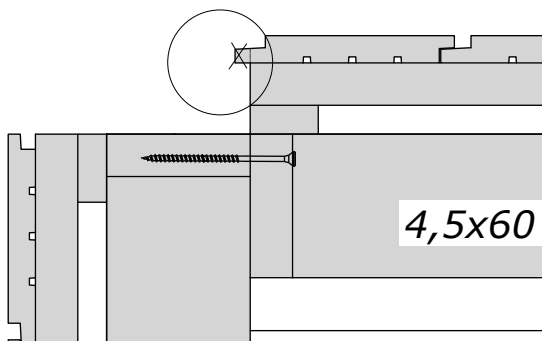

B

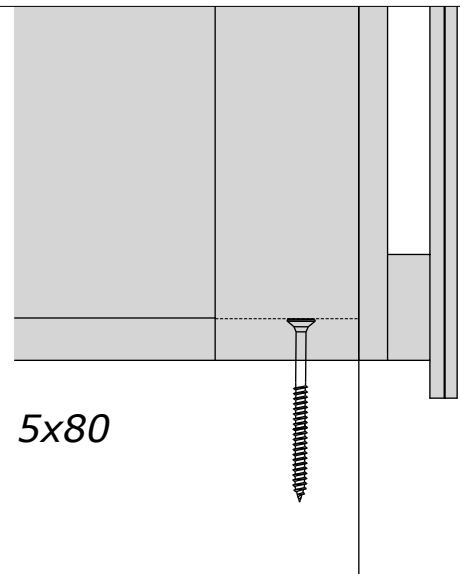

*Sla3* x1  
*Sla4* x1  
*Sla5* x2

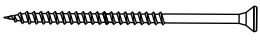
$\varnothing 5 \times 80$  x30 

*Sla4*

*Sla5*

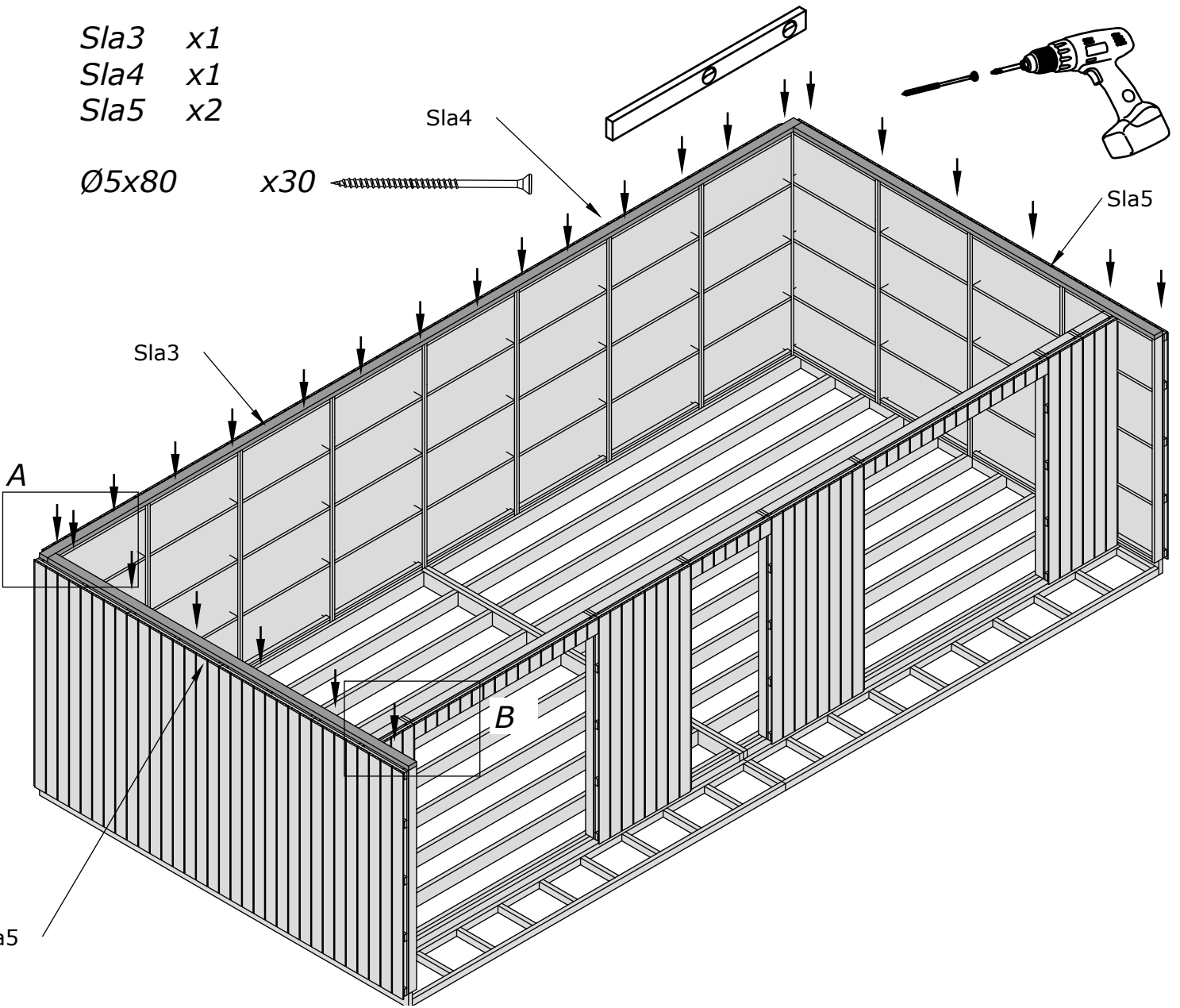

*A*

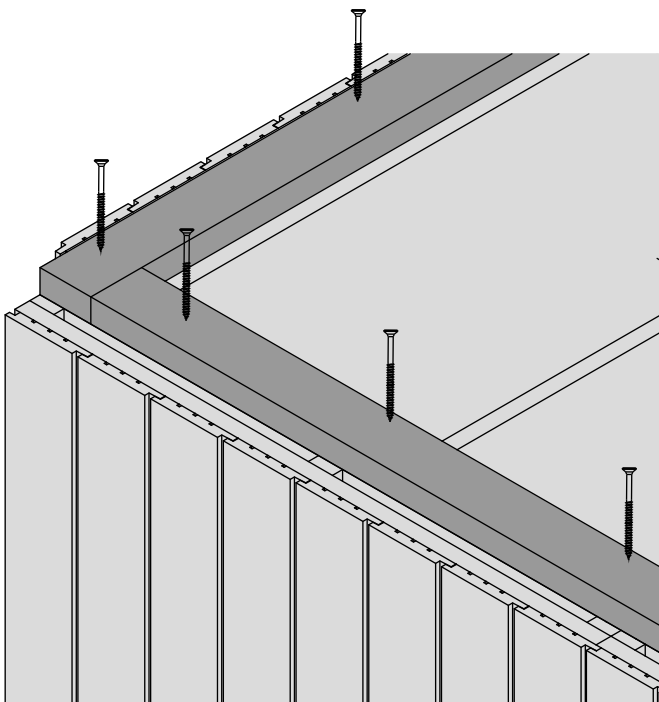

*B*

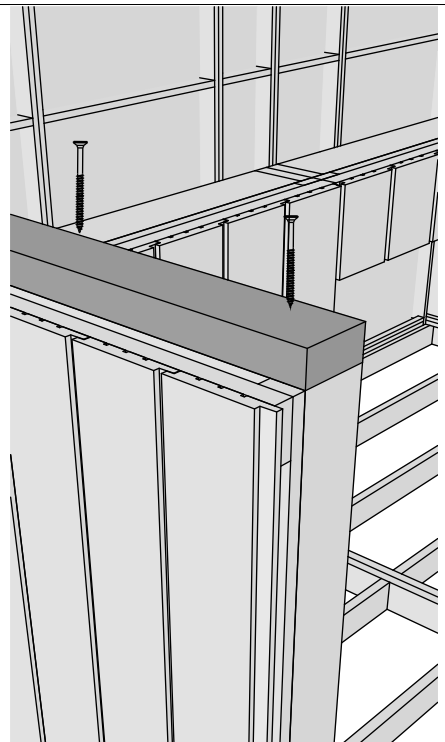

WG6-1 x4

WG6-2 x4



Ø4,8x28

x24

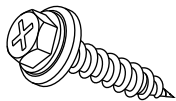
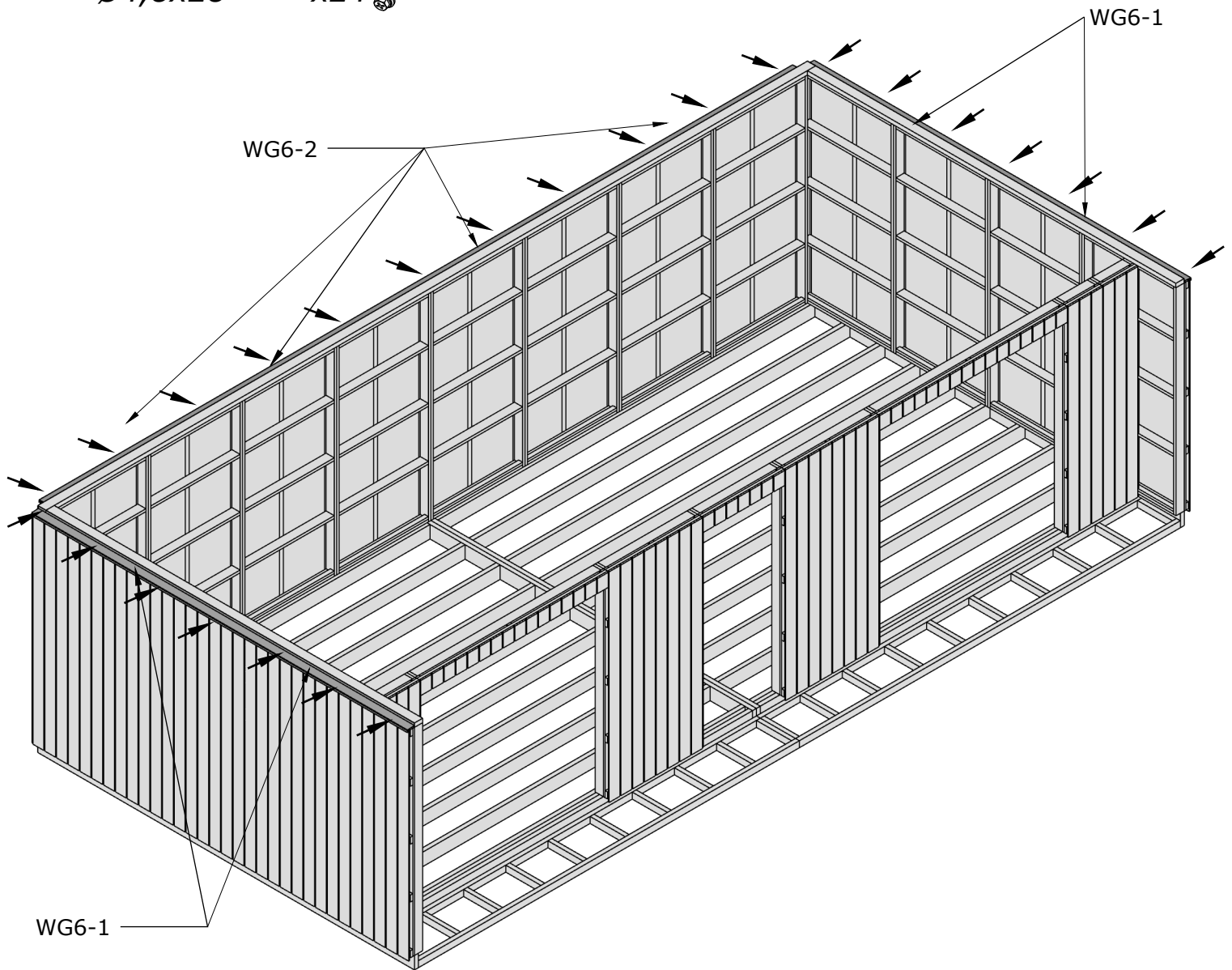
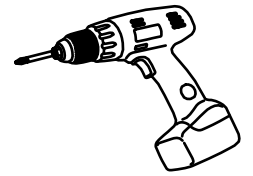

WG6

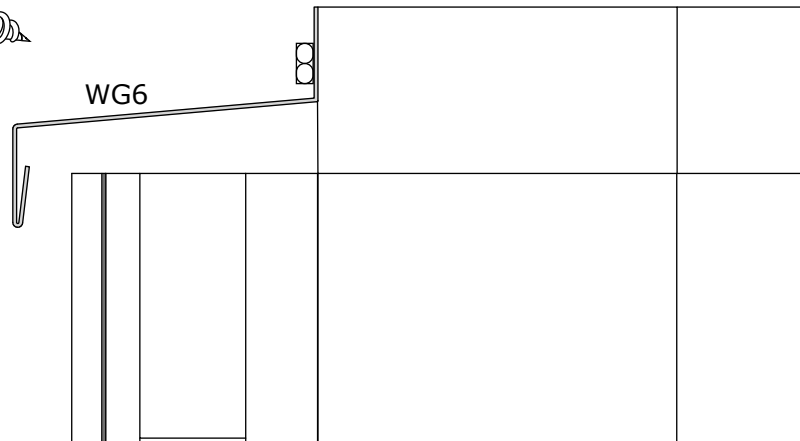

BM1 x1  
BM2 x1

Ø6X120 x10 

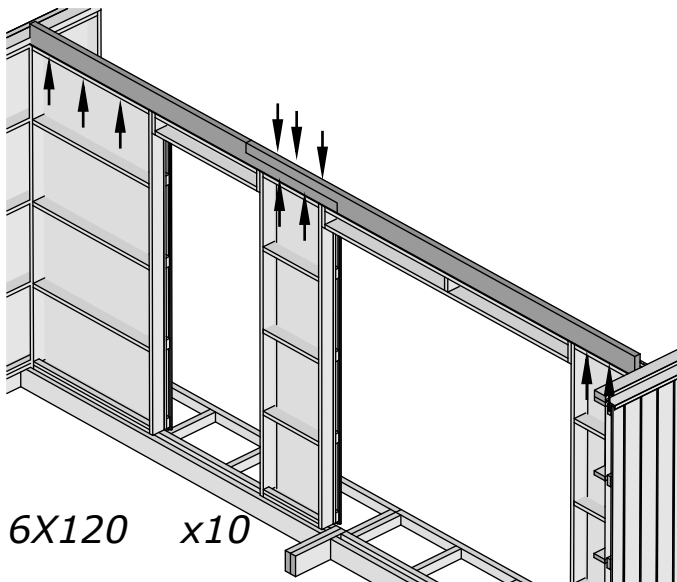
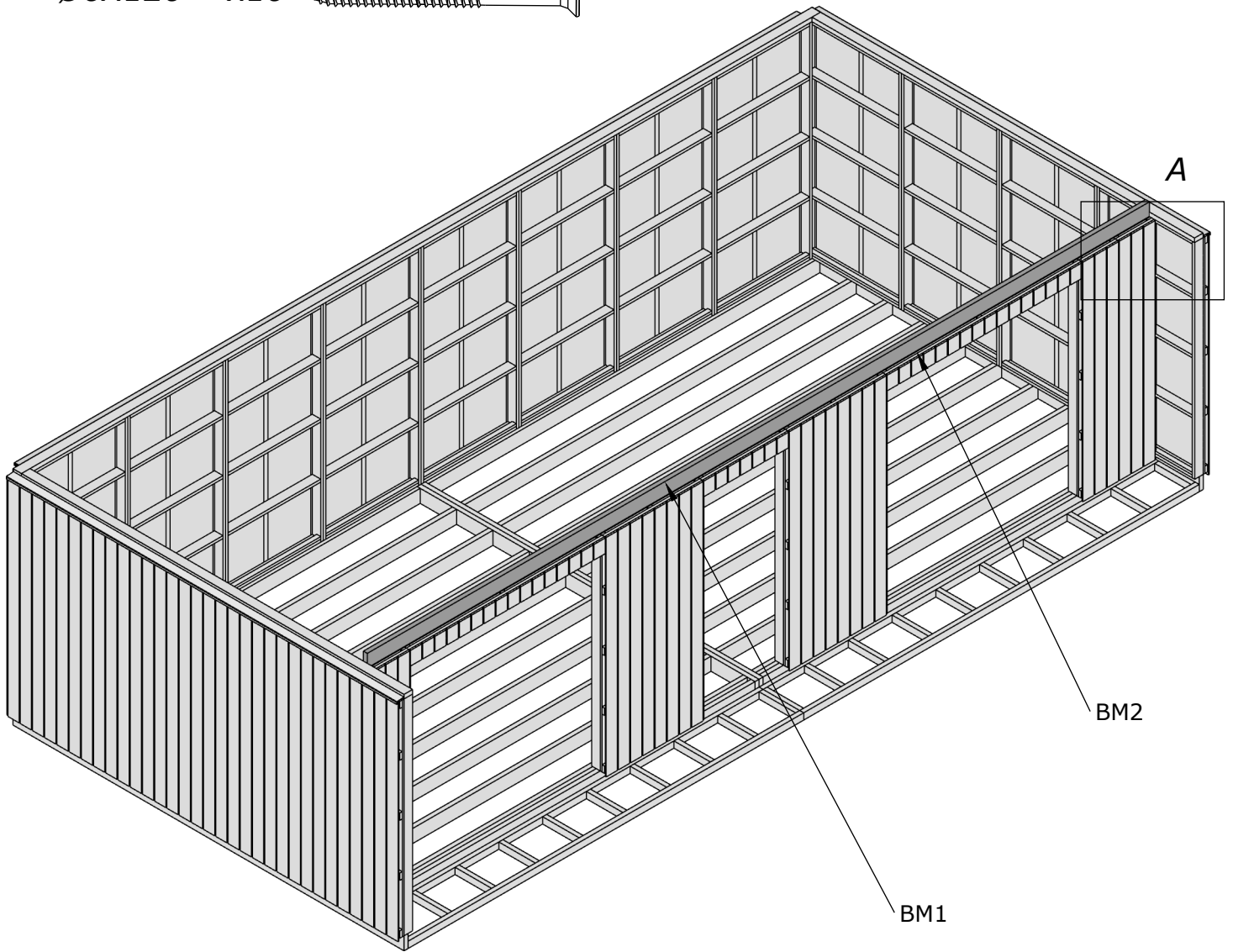
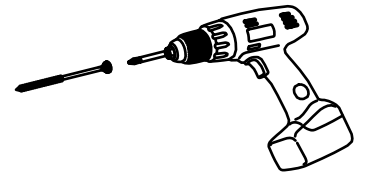

A

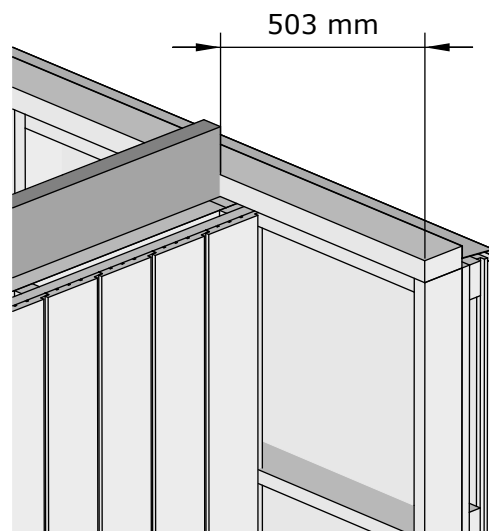

Sla1 x2

Sla2 x2

Ø4,5X60 x30

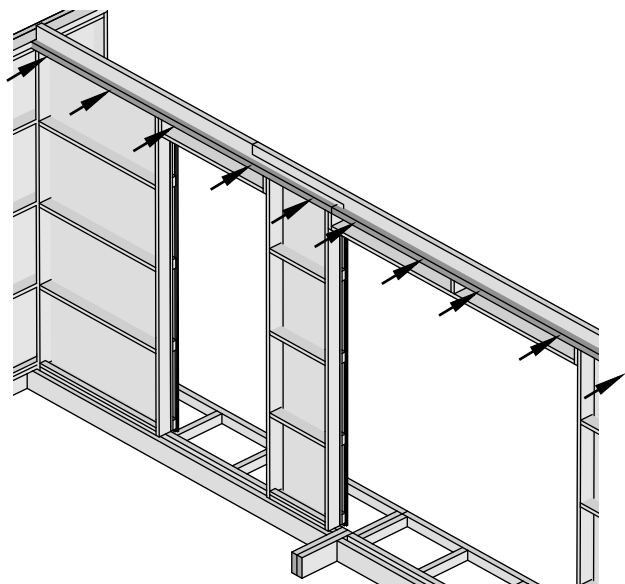
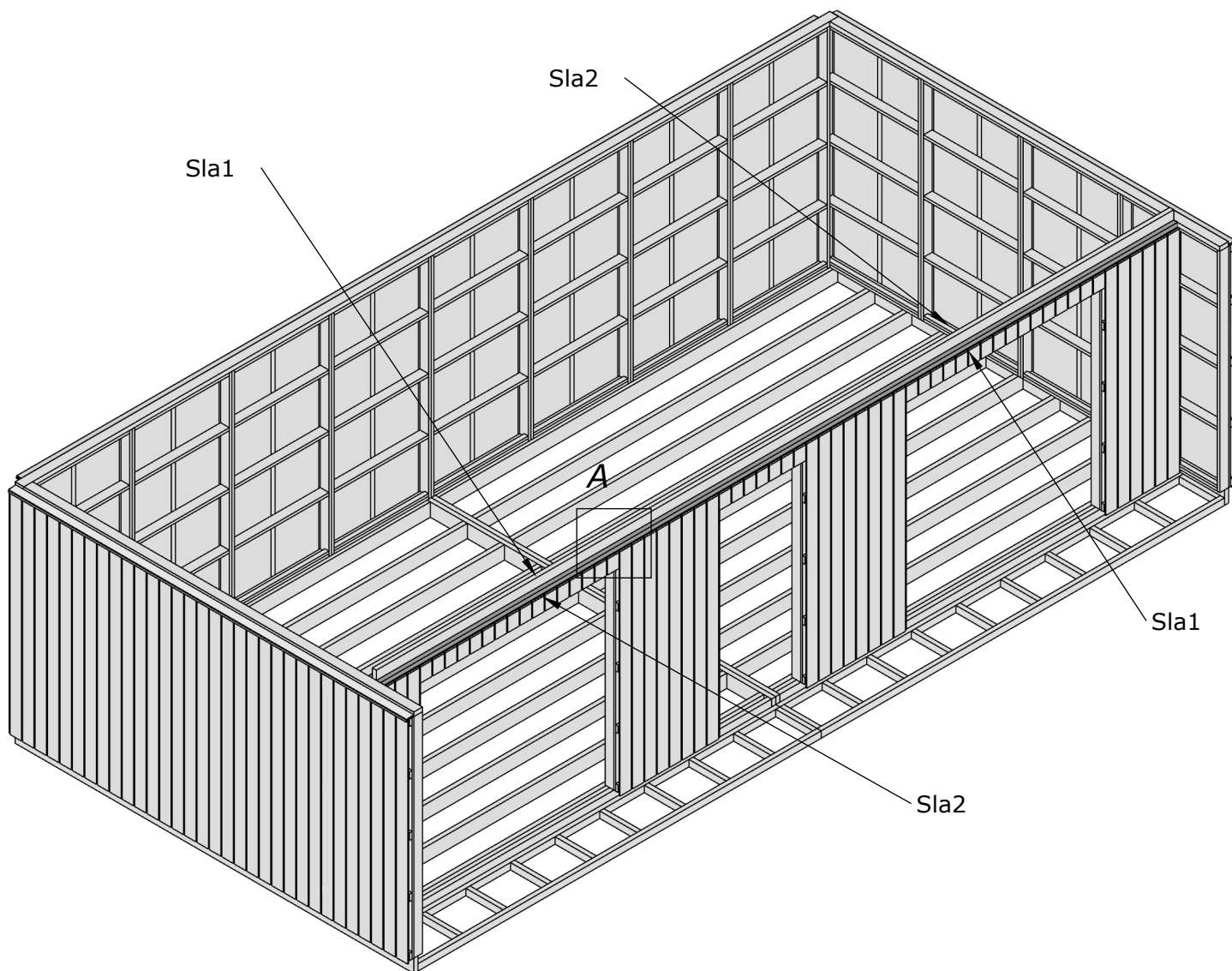
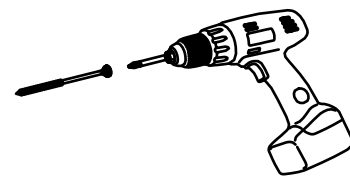
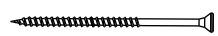

A

BM1-BM2

Sla1 - Sla2

Sla2 - Sla1

4,5x60

4,5x60

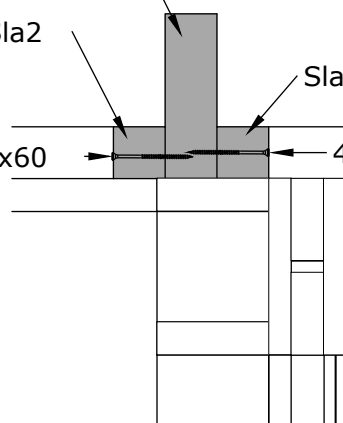

- ELEL1 x6
- ELEL2 x2
- ELEL3 x18
- ELEL4 x1

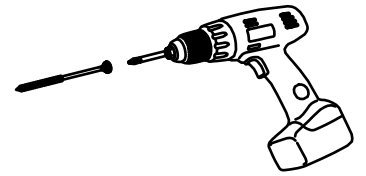

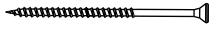
Ø4,5X60 x76 

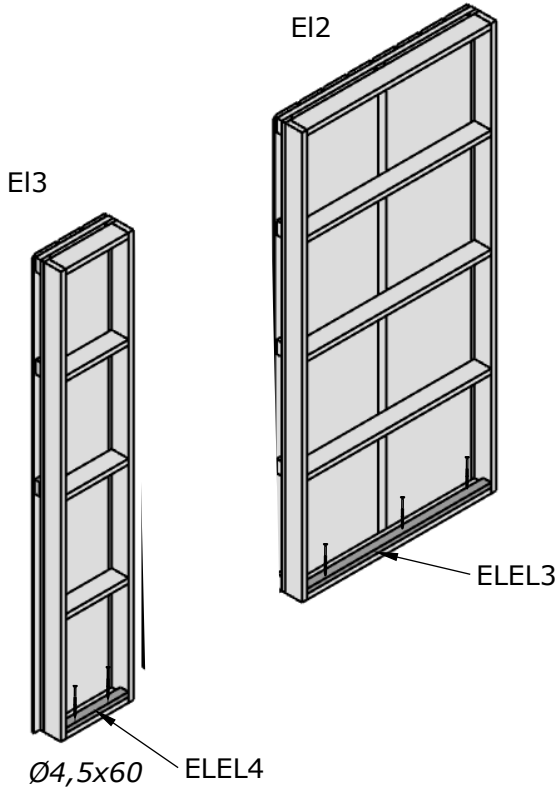
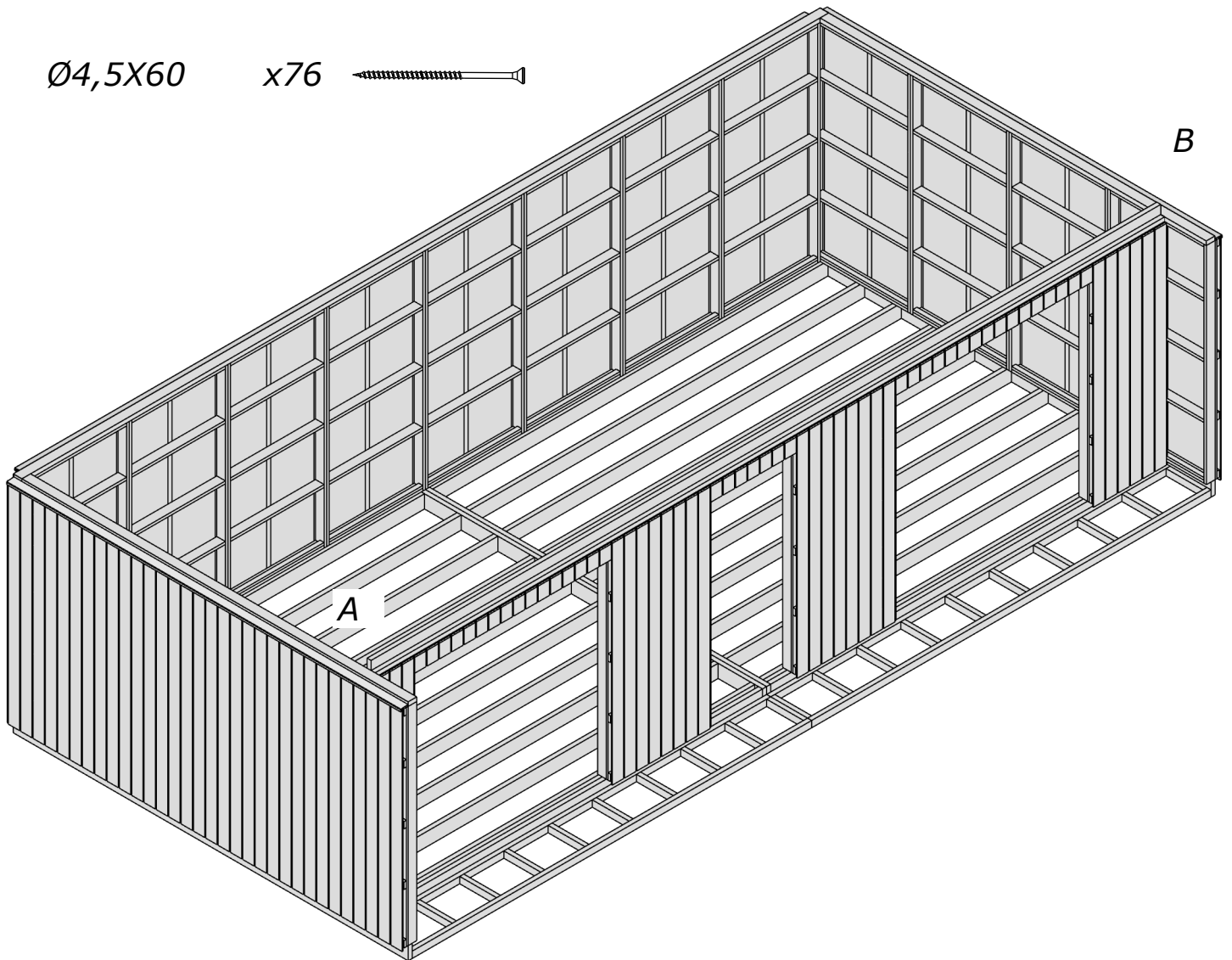

A - B

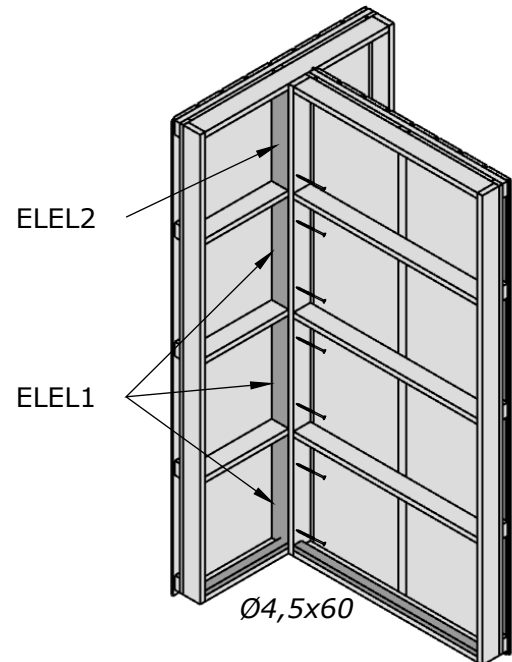

E119 x4

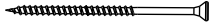
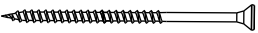
Ø4,5X60 x12   
Ø5X80 x24 

5x80

4,5x60

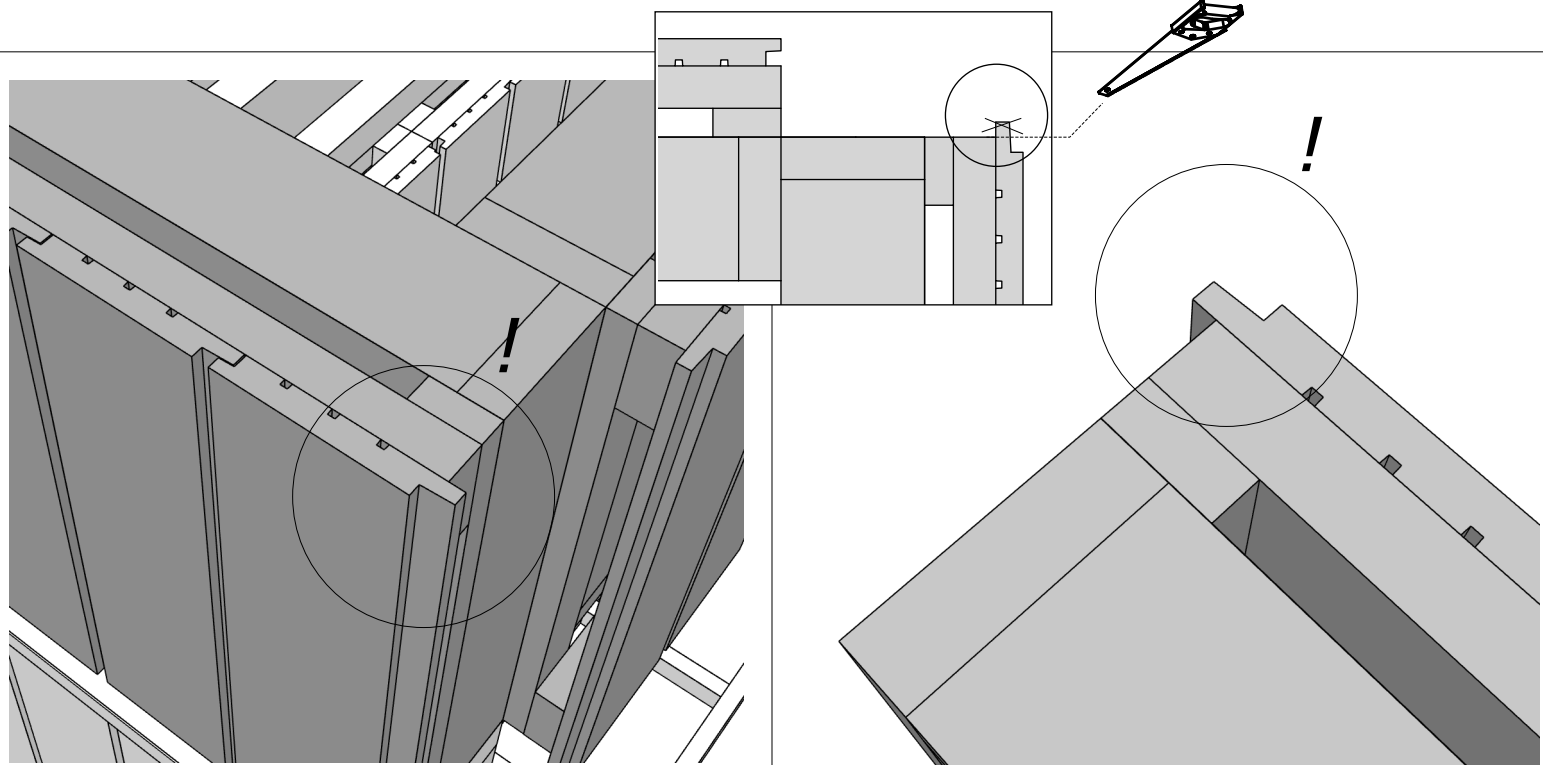
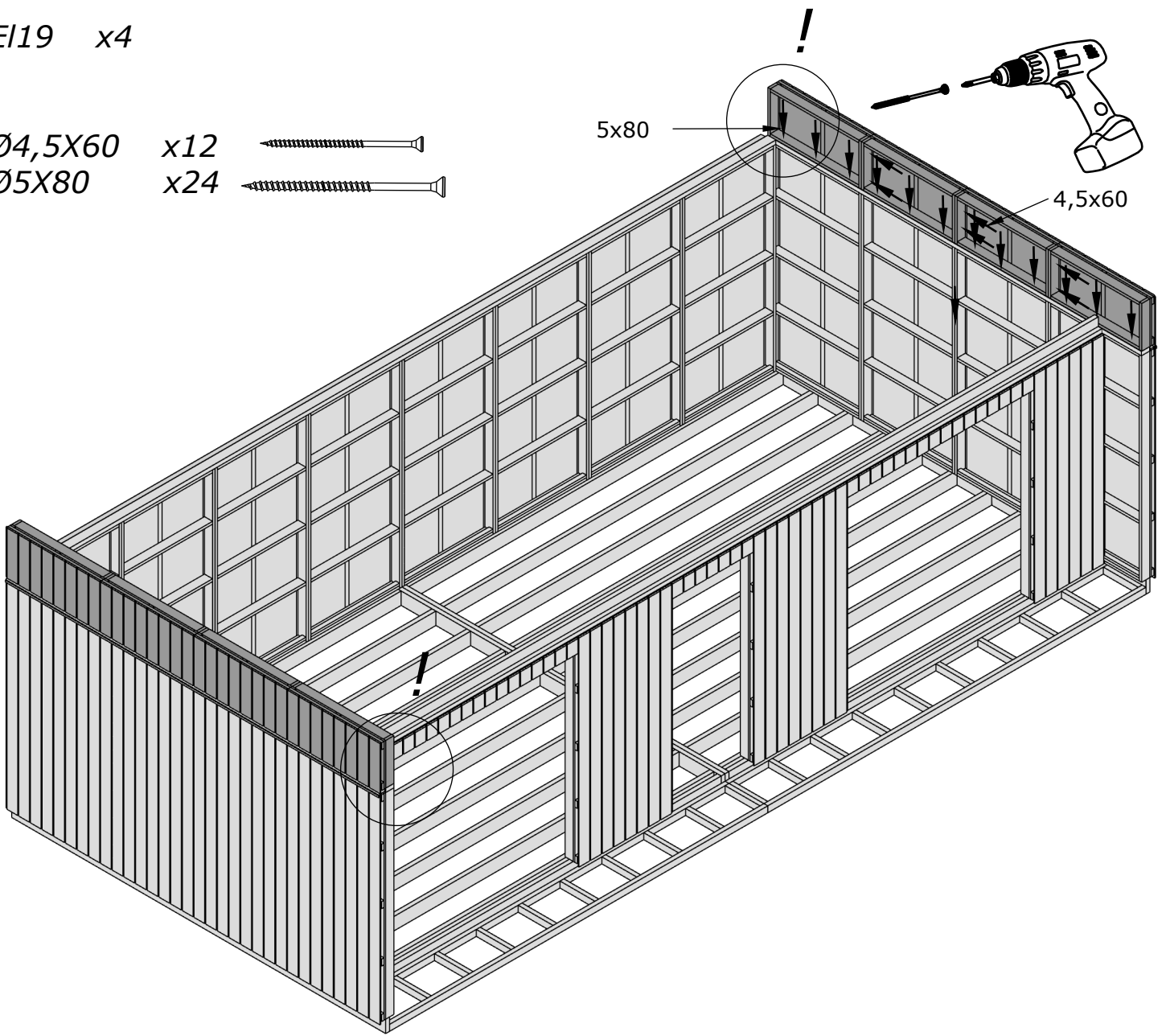

Ror1 x17  
Ror2 x17  
Ror3 x17  
Ror4 x17

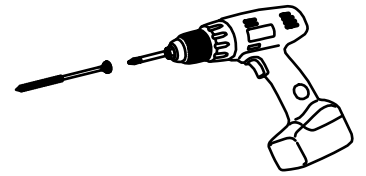

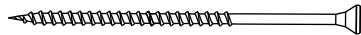
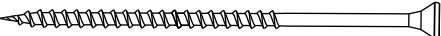
Ø6X160 x34  (A)  
Ø8X240 x119  (B)

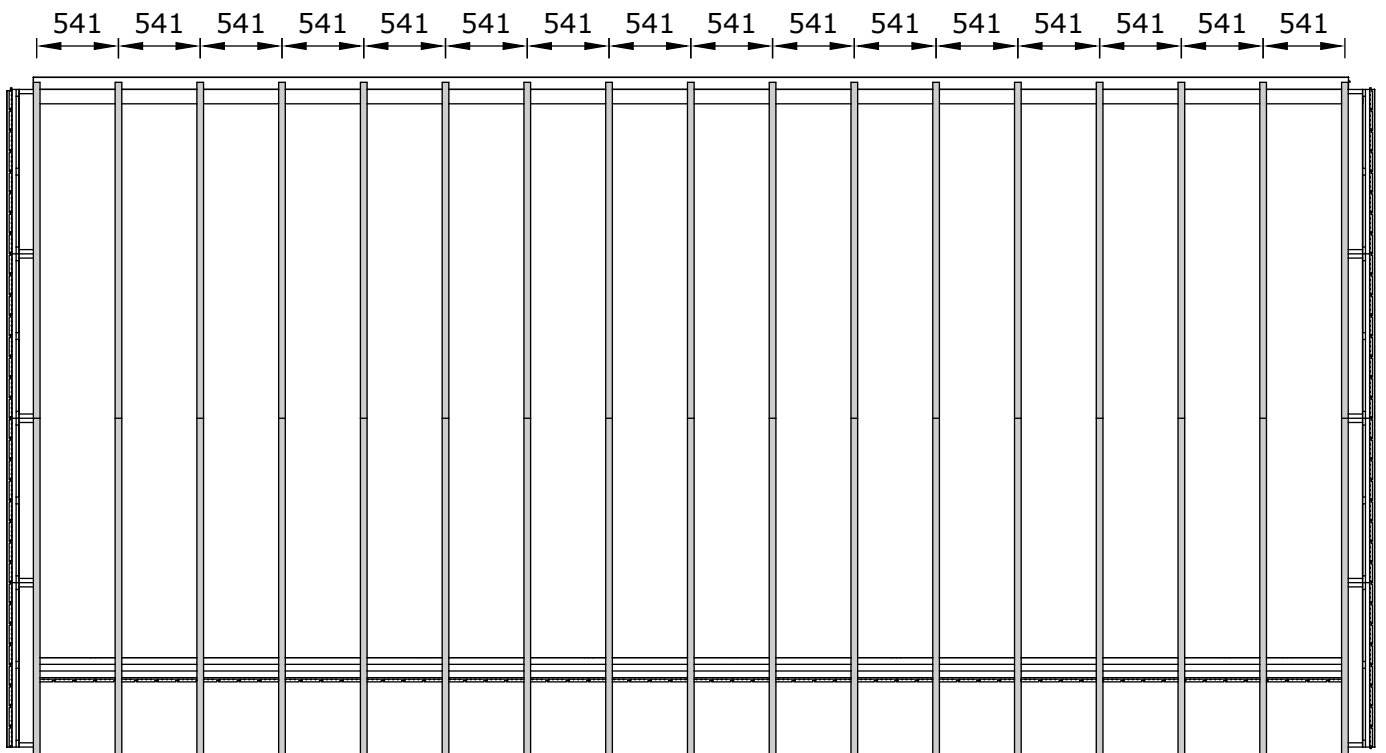
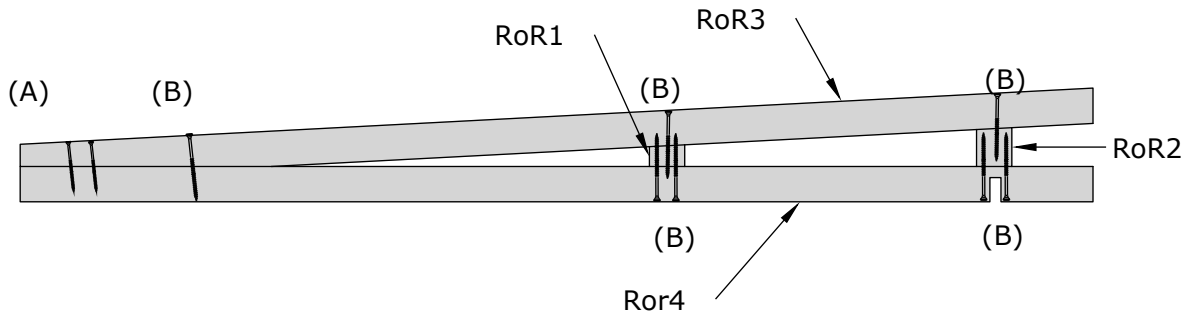

Ø5X80

x8

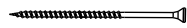

Ø6X120

x17

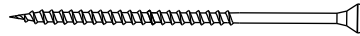

Ø6X160

x51

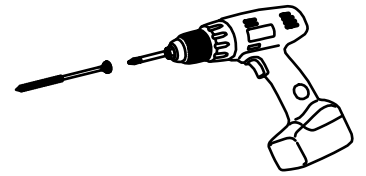
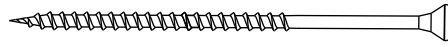

8x(5x80)

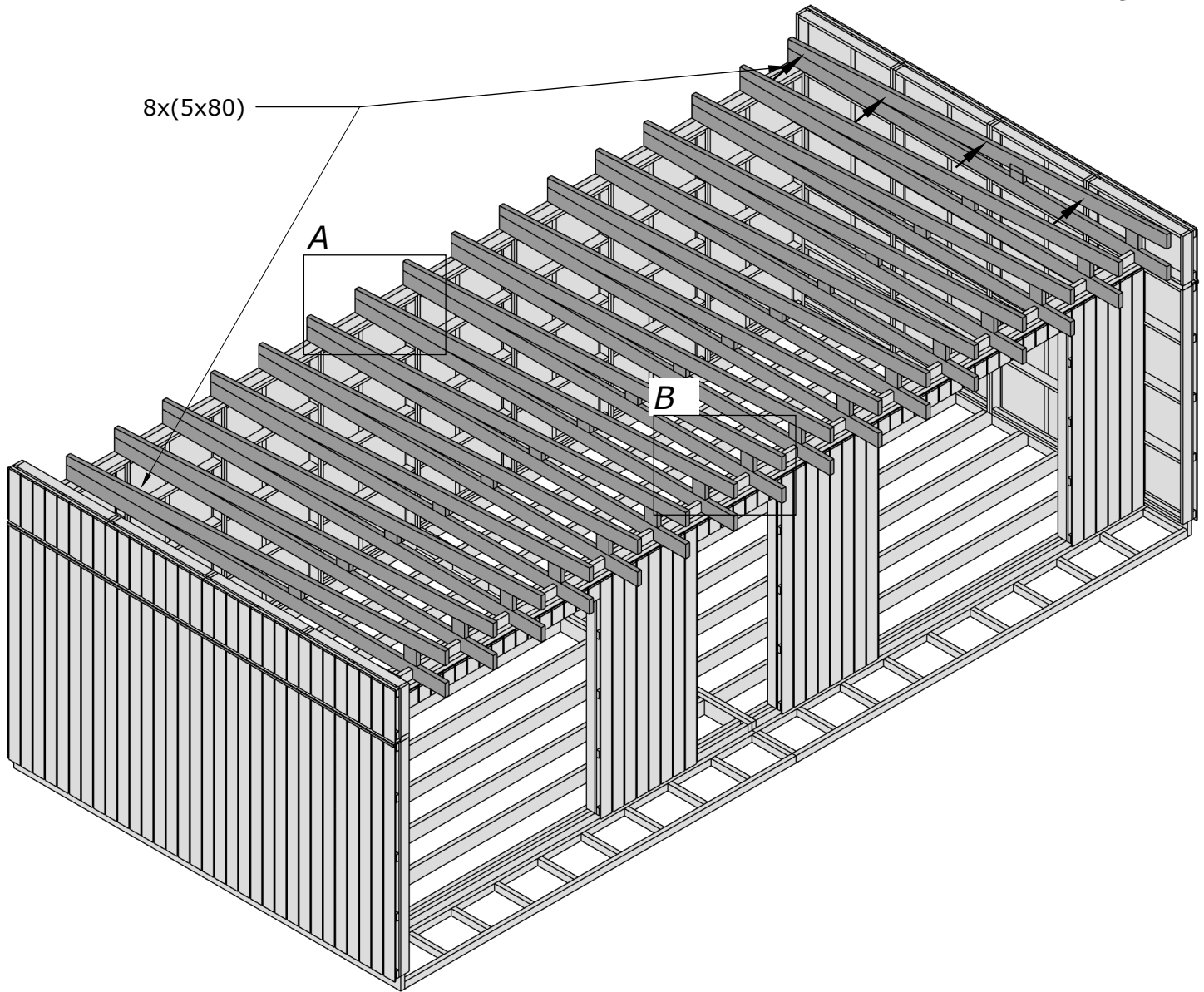

A

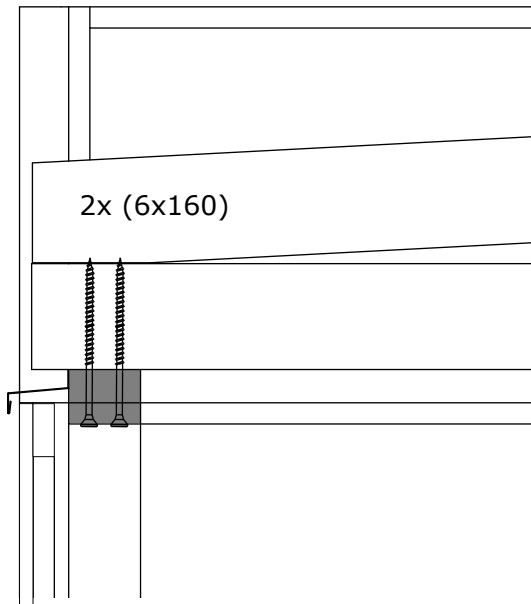

B

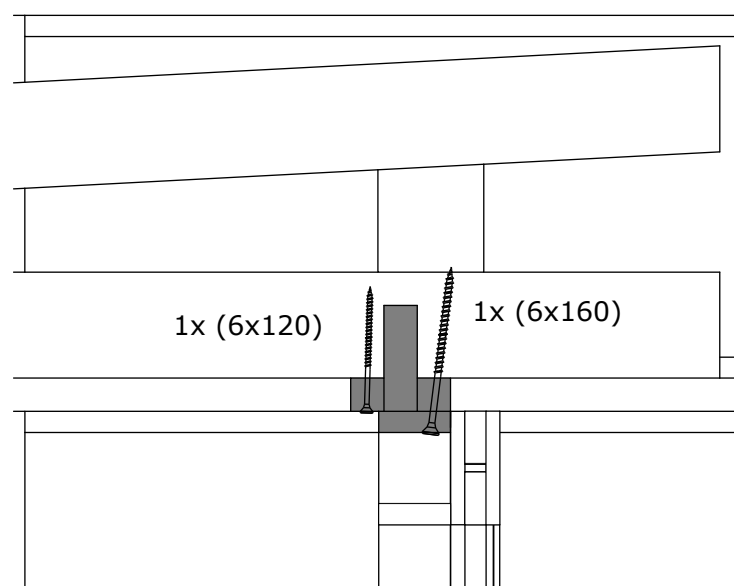

*Sla1*     x2  
*Sla2*     x2

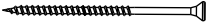
Ø5x80    x68     

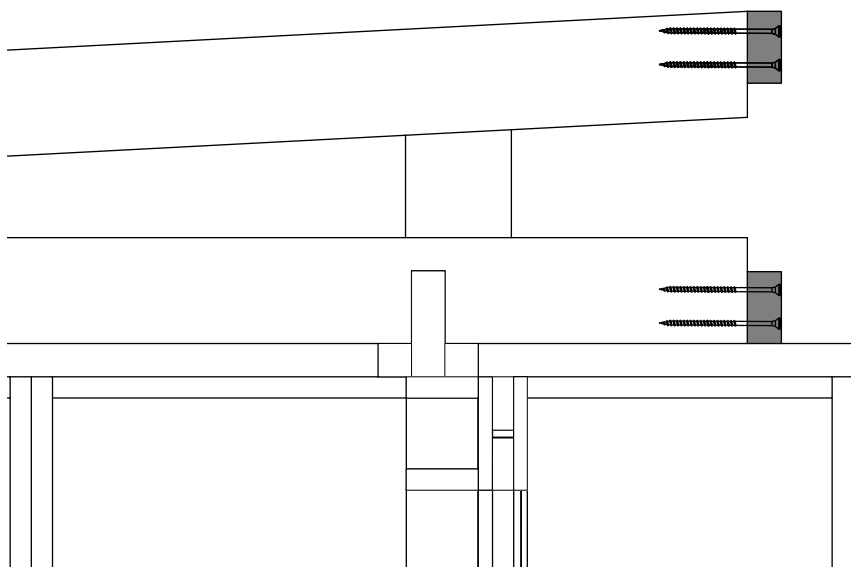
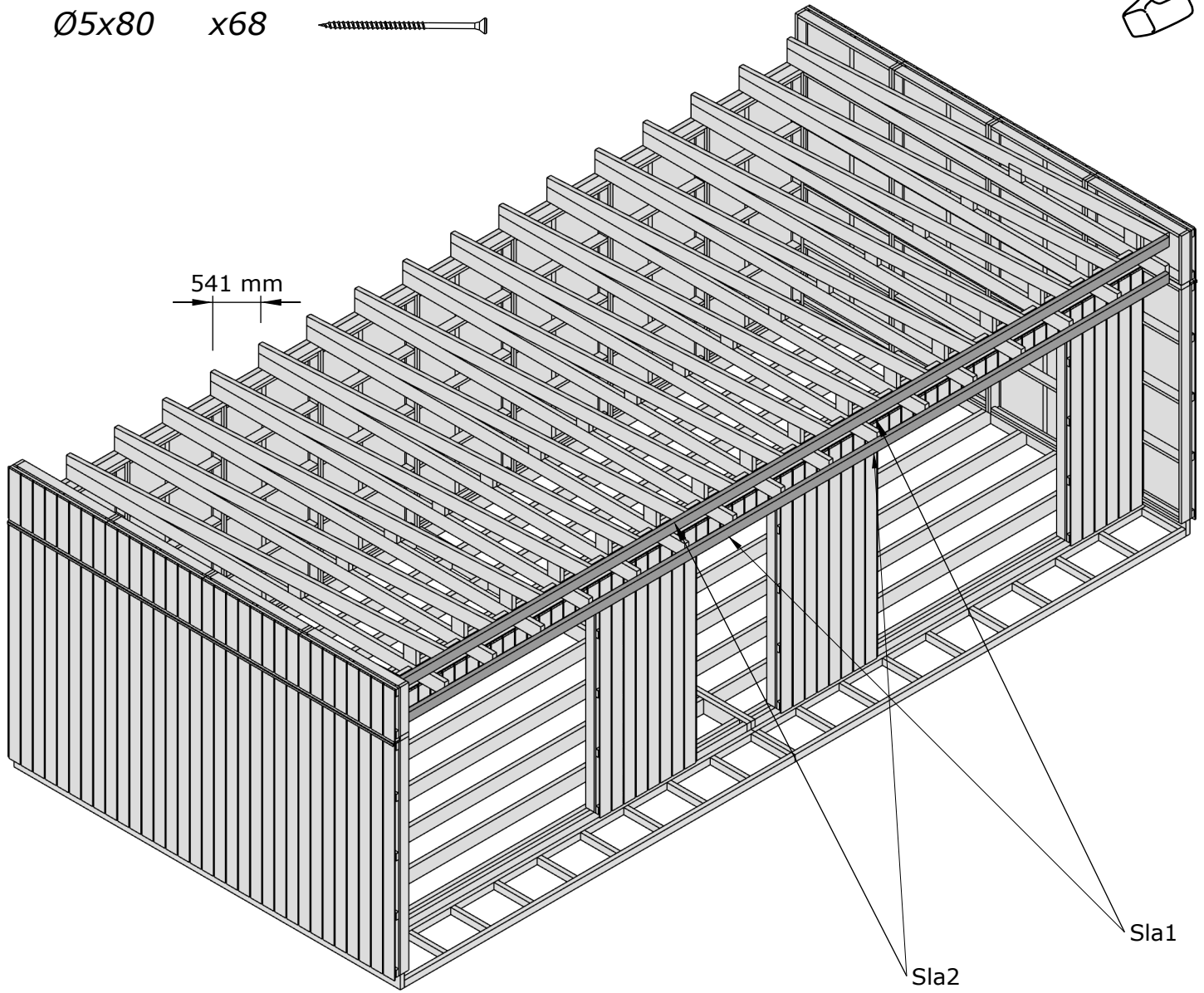
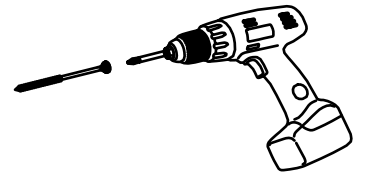

E19 x8

Ø5x80 x68

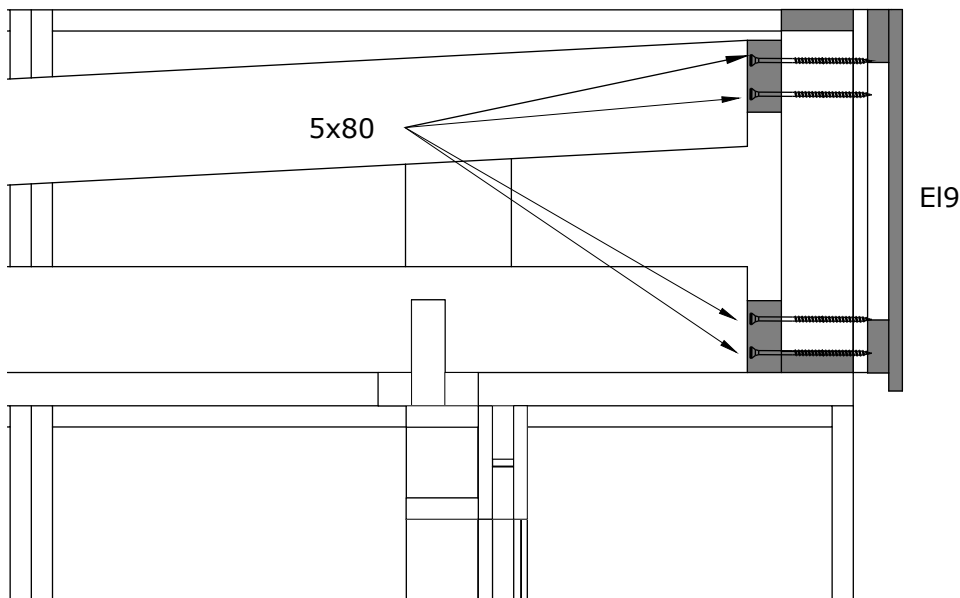
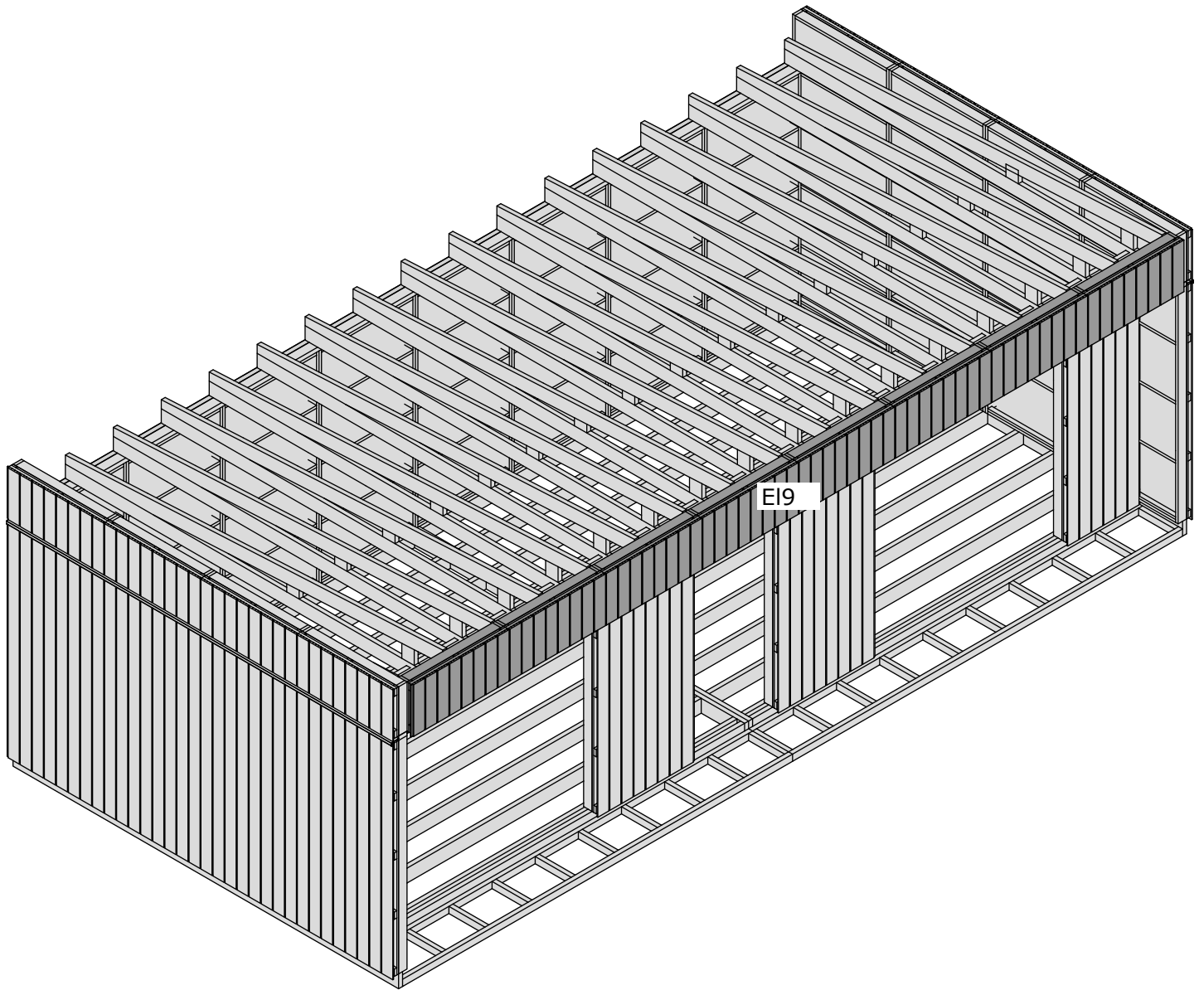
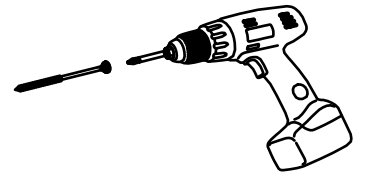
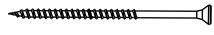

PST1 x4

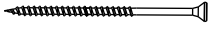
Ø5x80 x16 

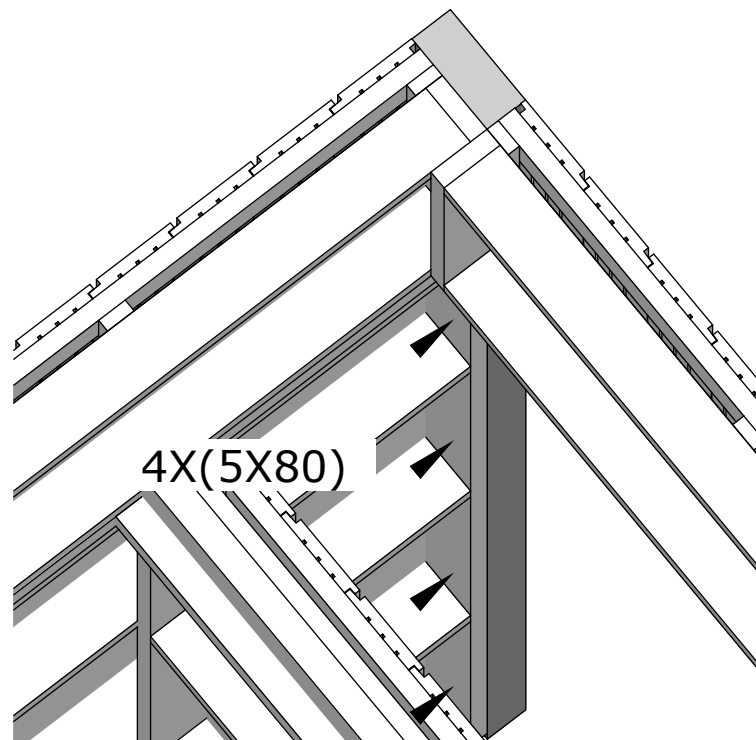
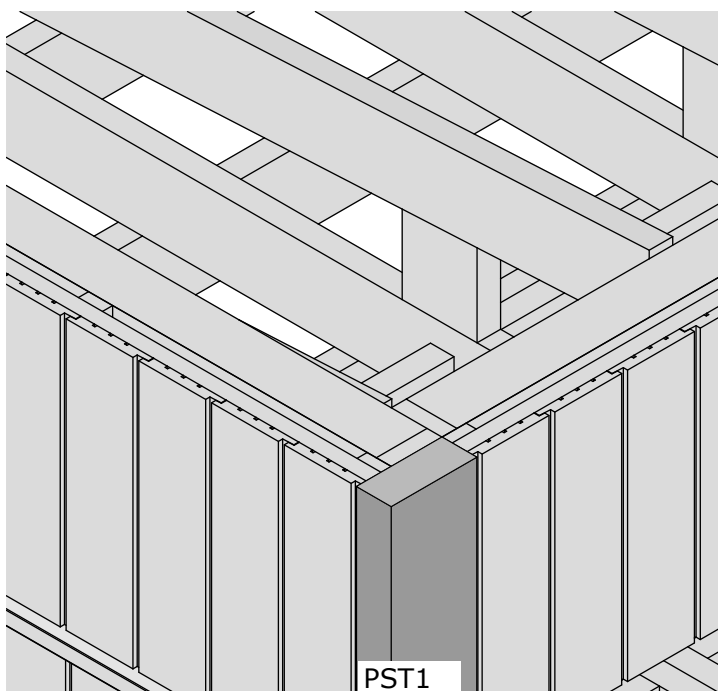
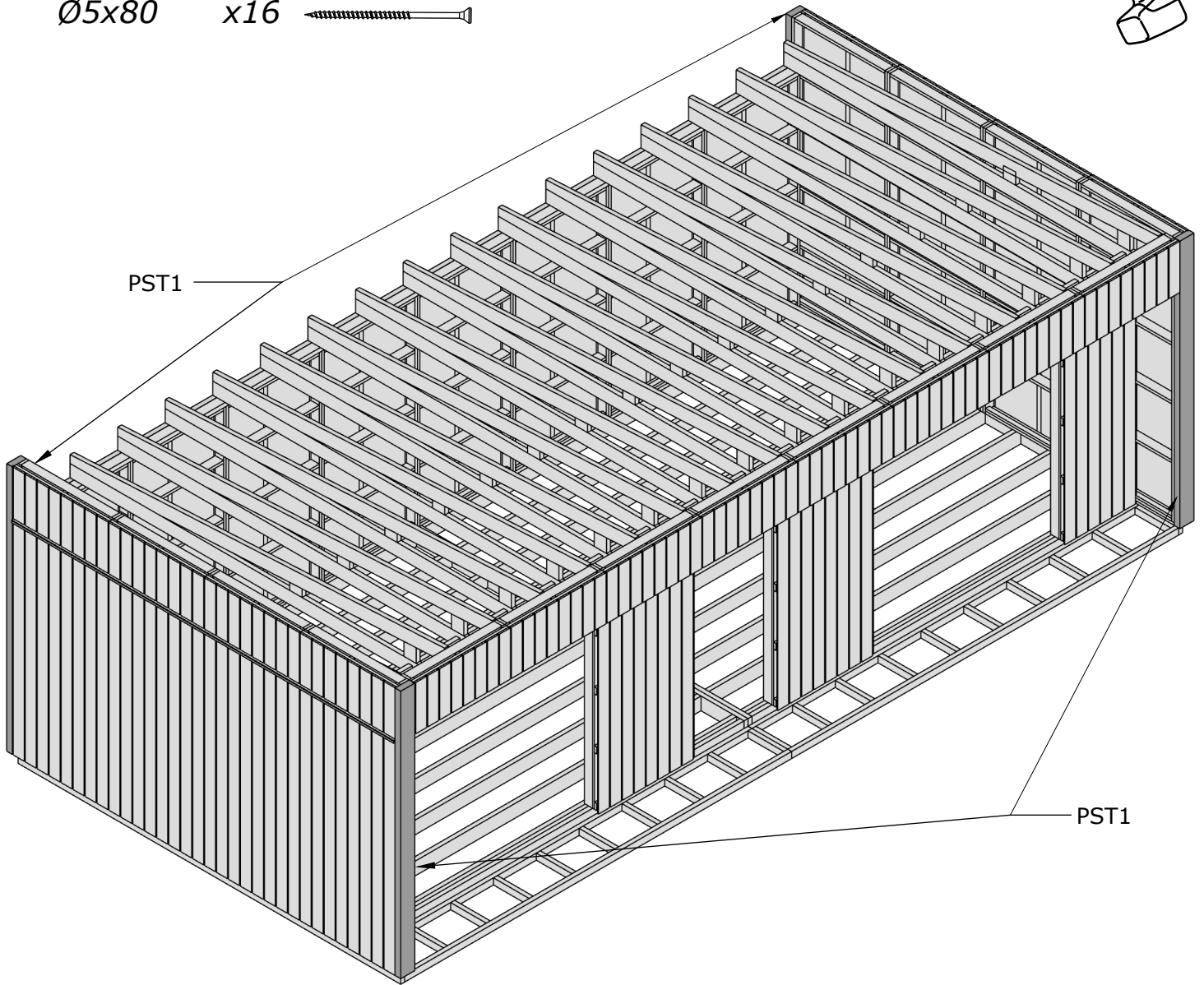
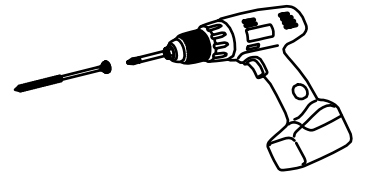

RB2-1 x51

RB2-2 x51

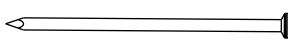
Ø3X70 x1000 

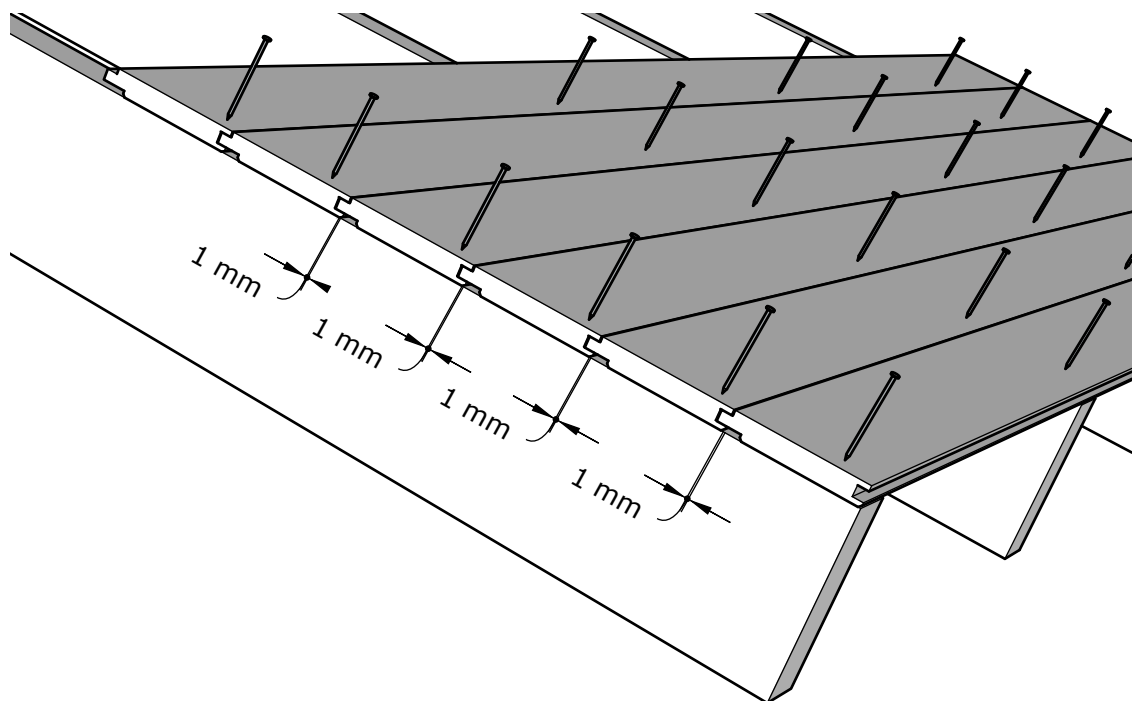
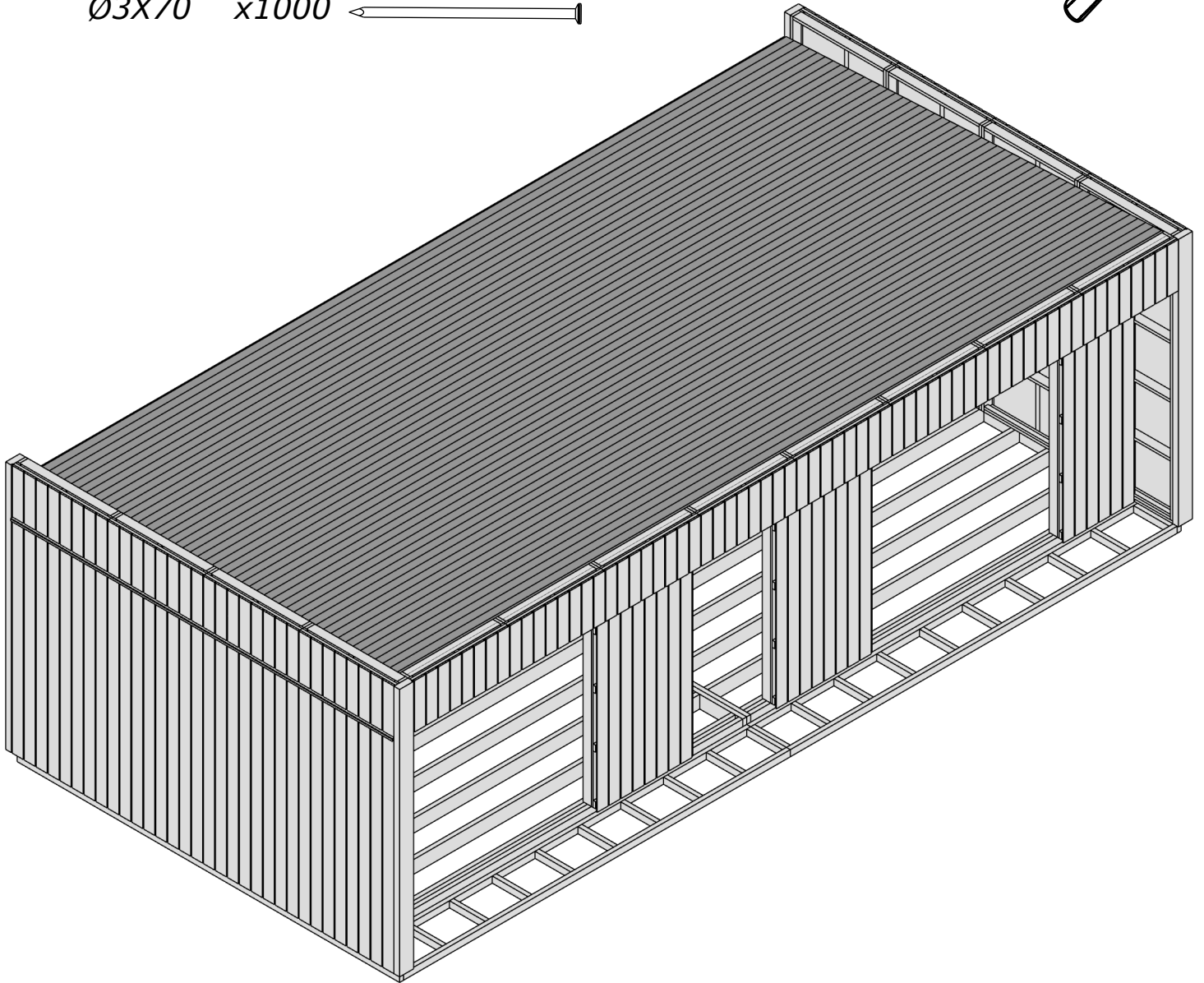
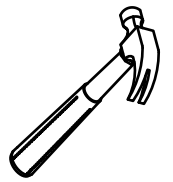

FB5-1 x3

FB5-2 x3

Ø4,5X60 x66 

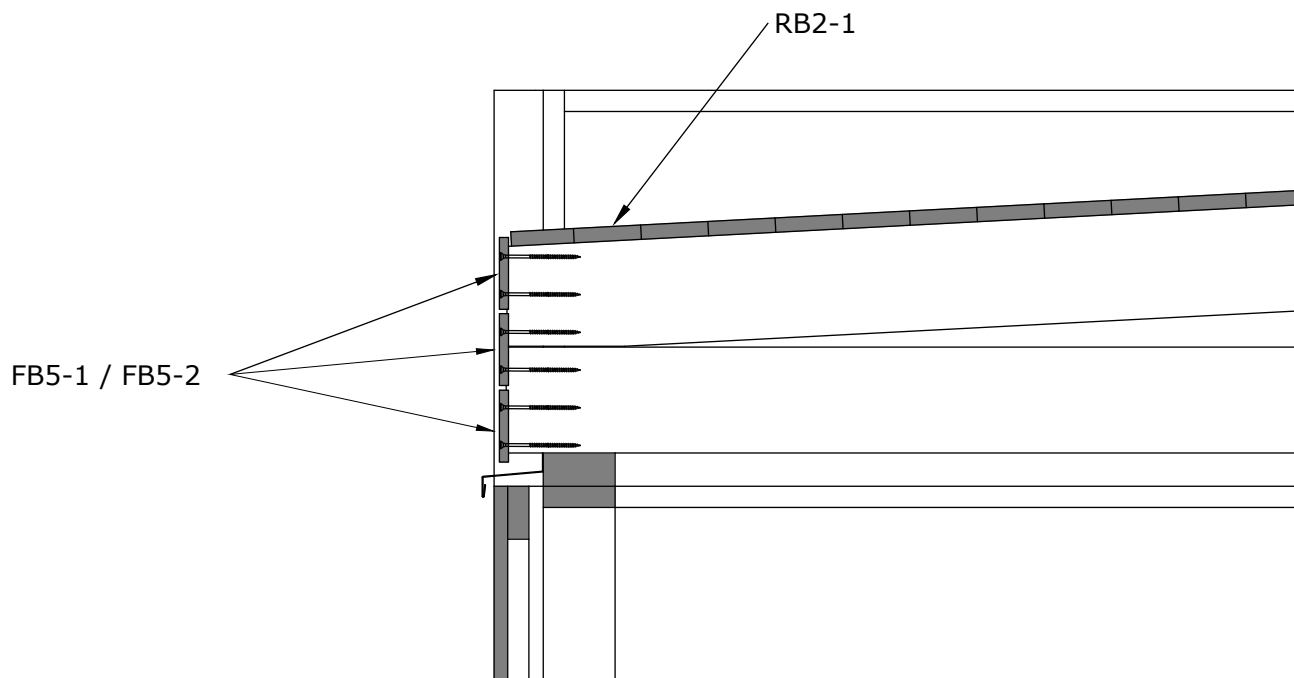
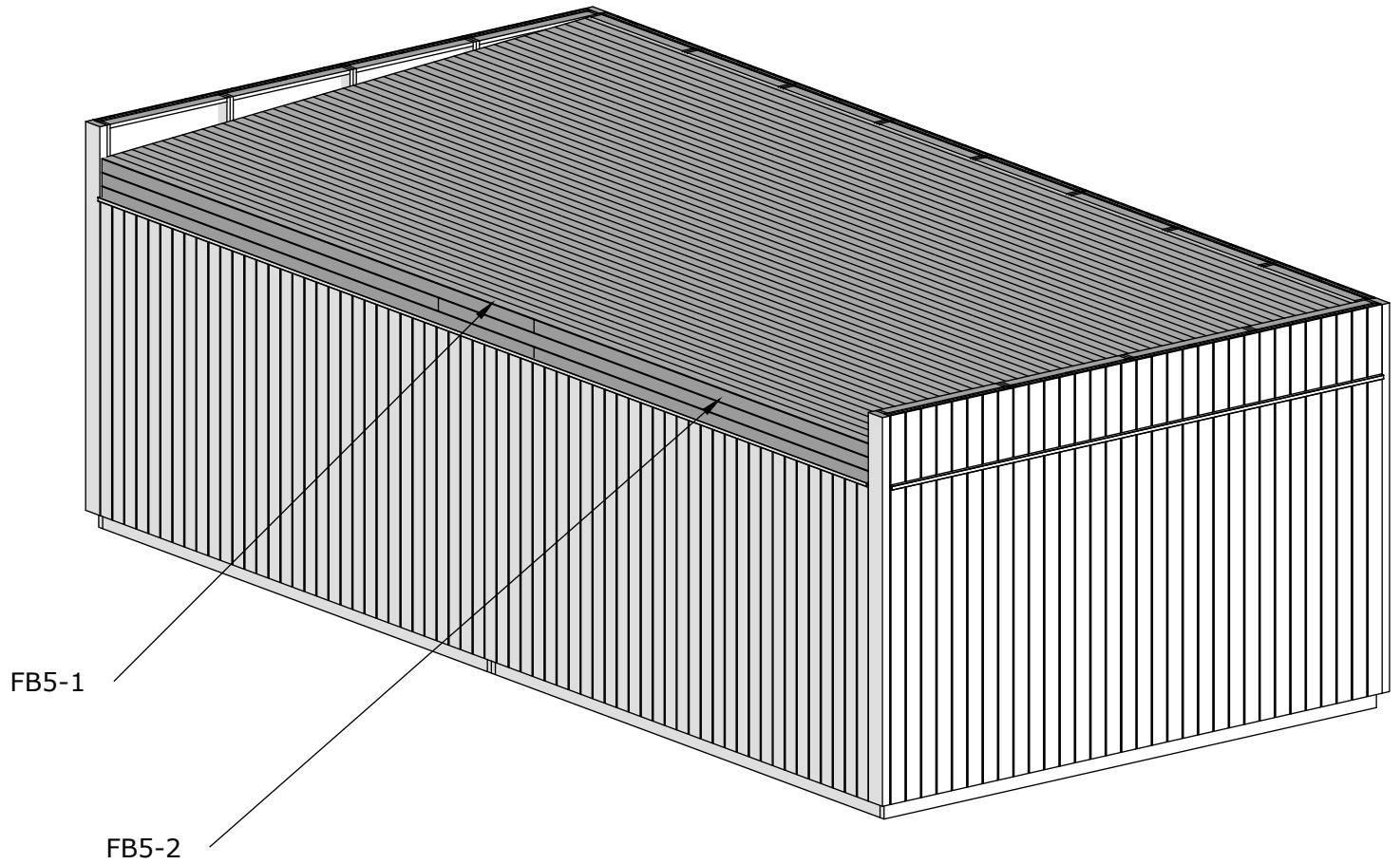
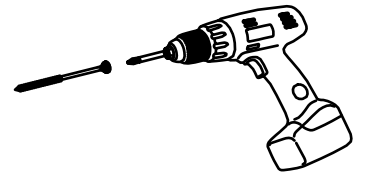

WG10-1 x4

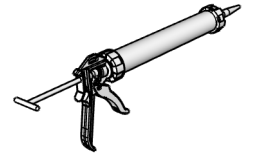
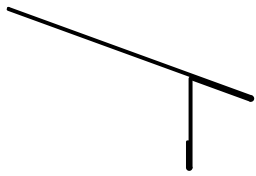

WG10-1

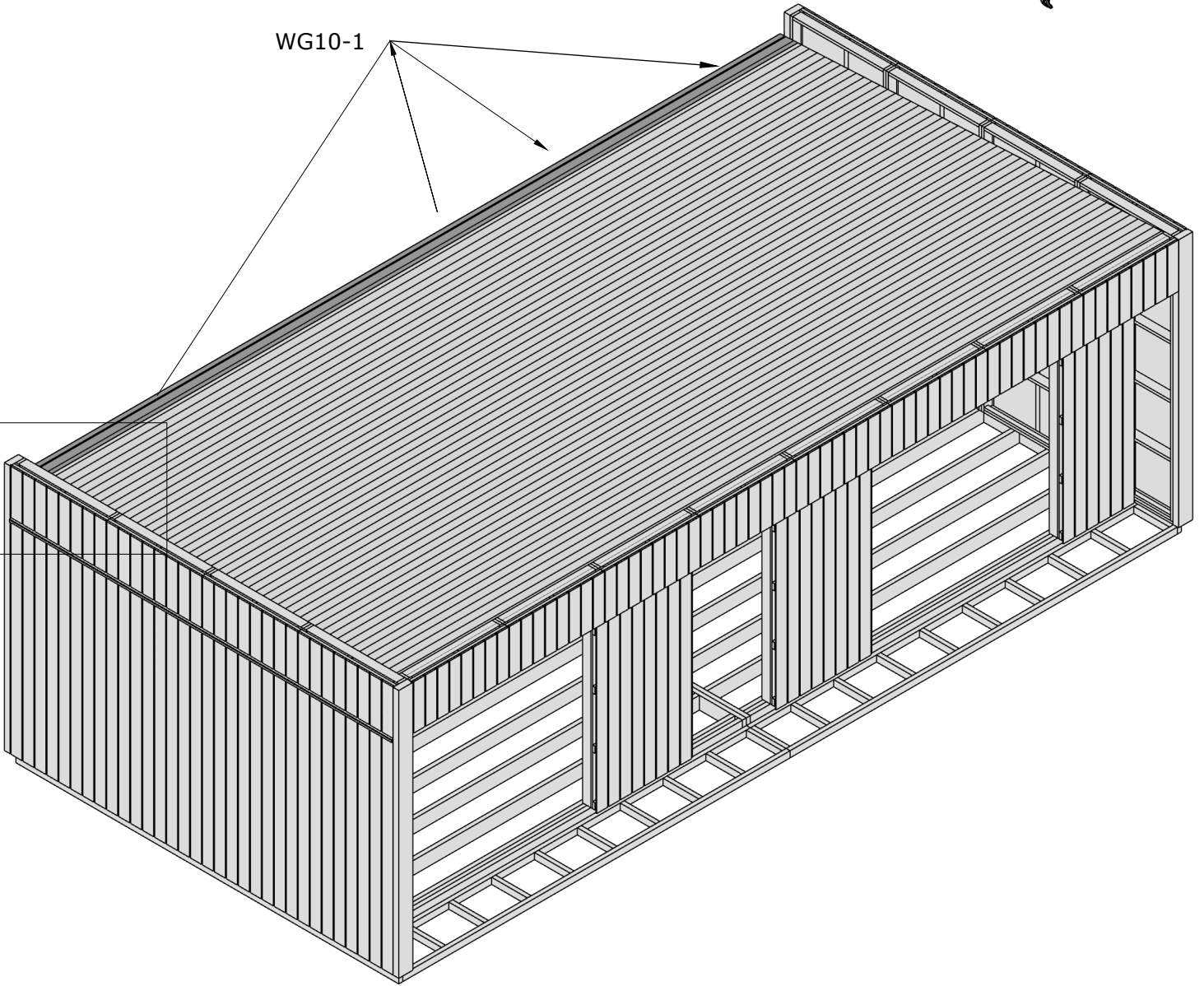

WG10-1

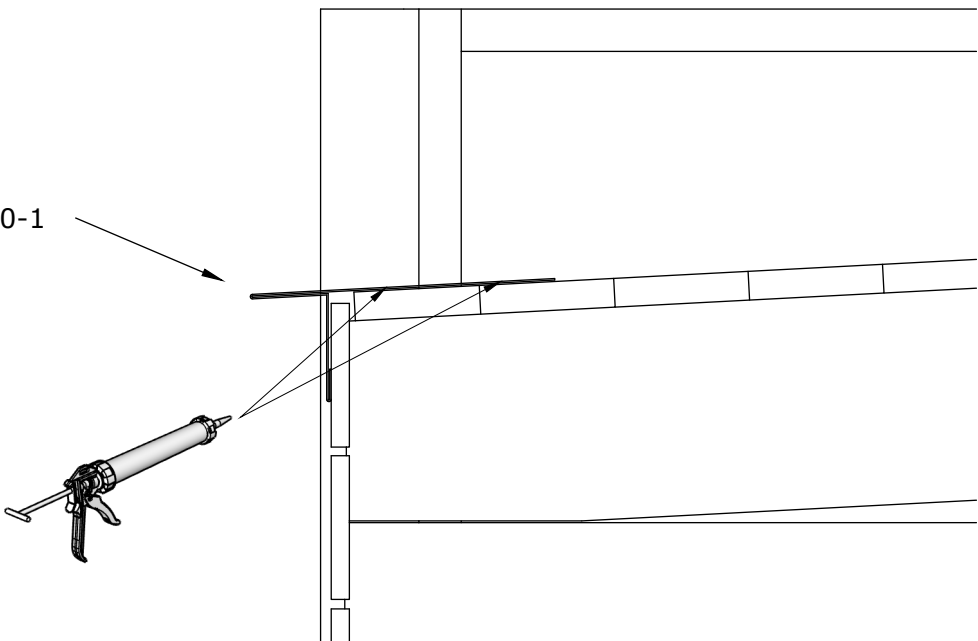

OSB\_1 x2  
OSB\_2 x2  
OSB\_3 x2

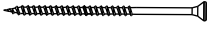
Ø4,5X60 X12 

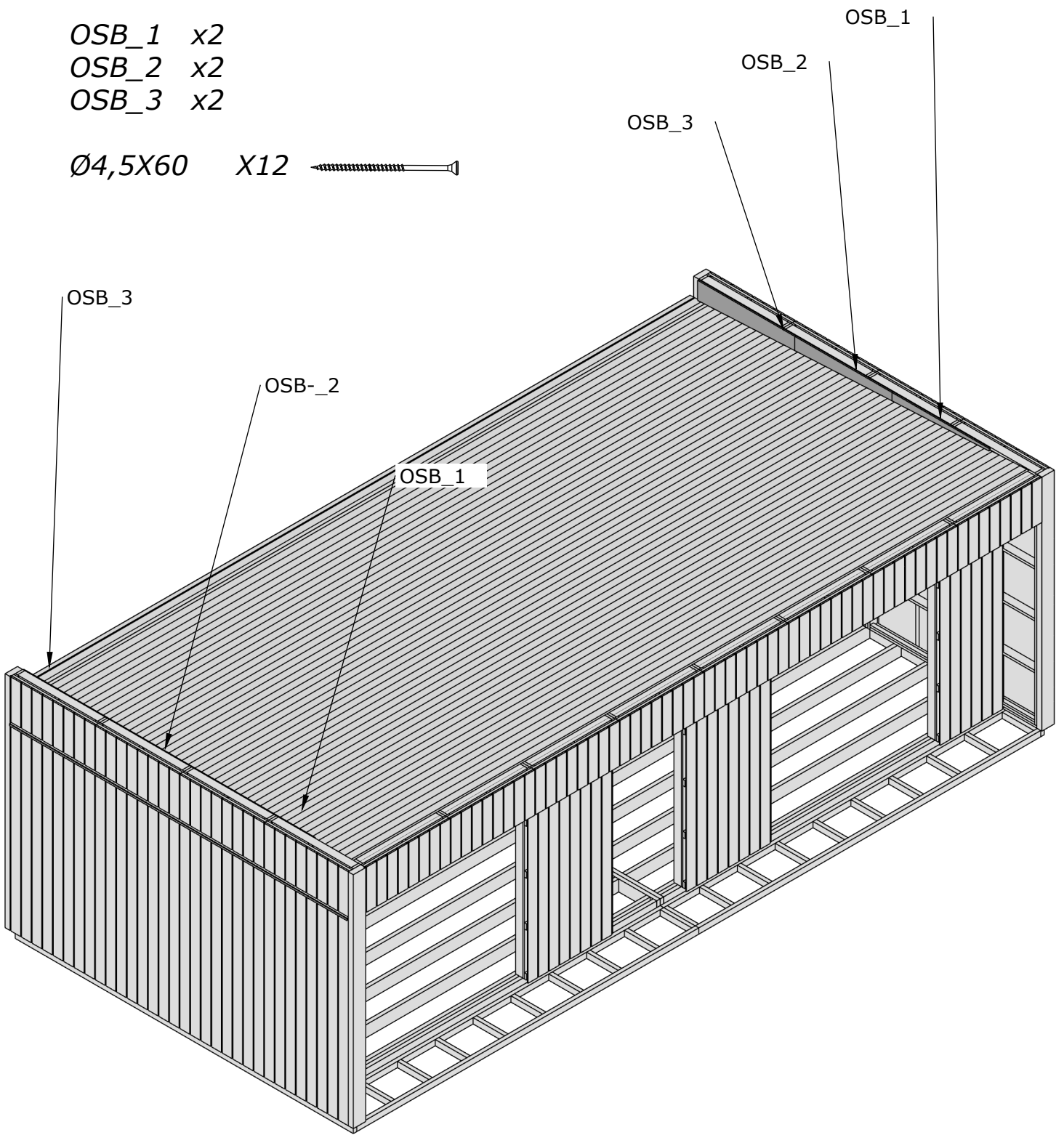

OSB\_3

OSB\_2

OSB\_1

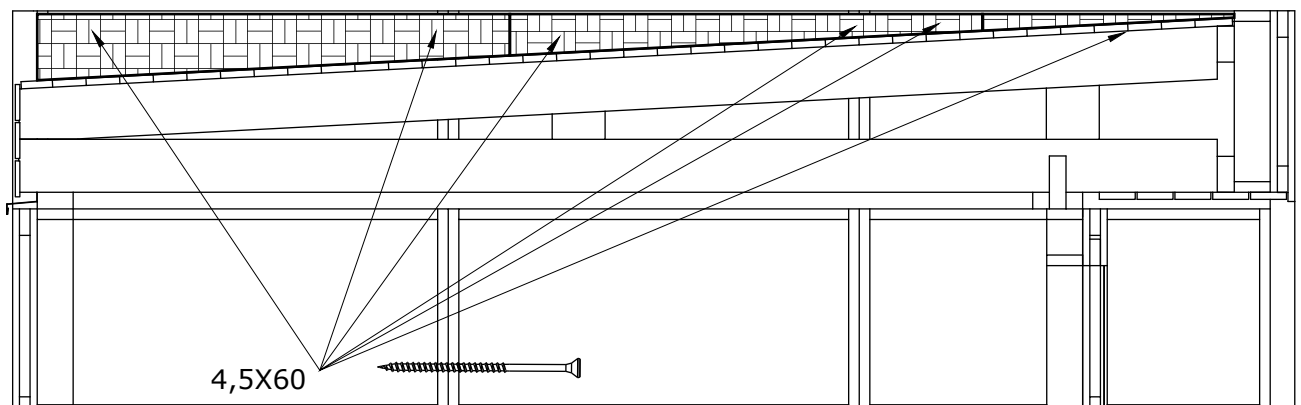

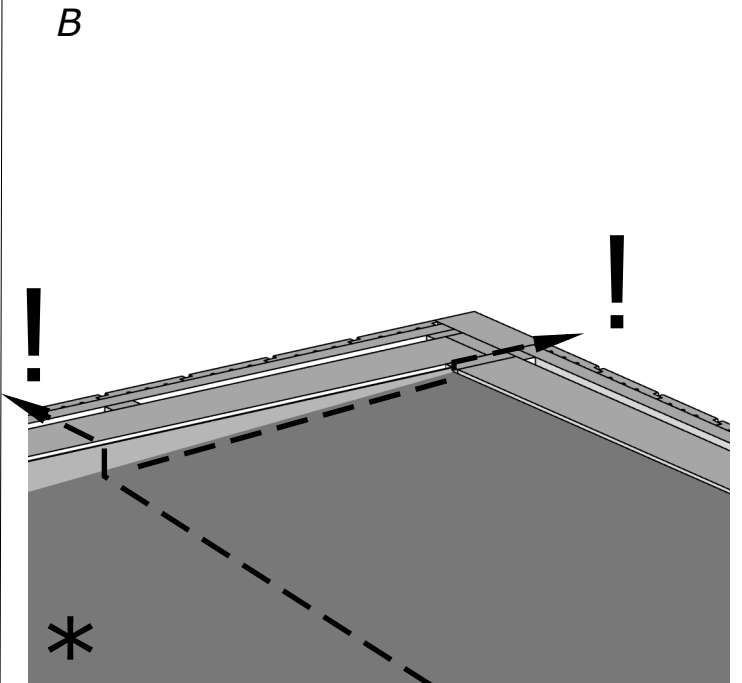
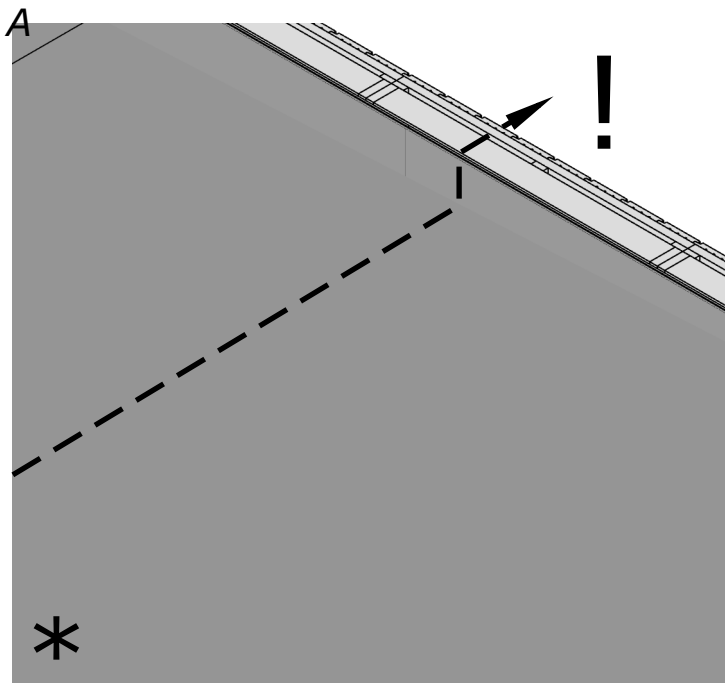
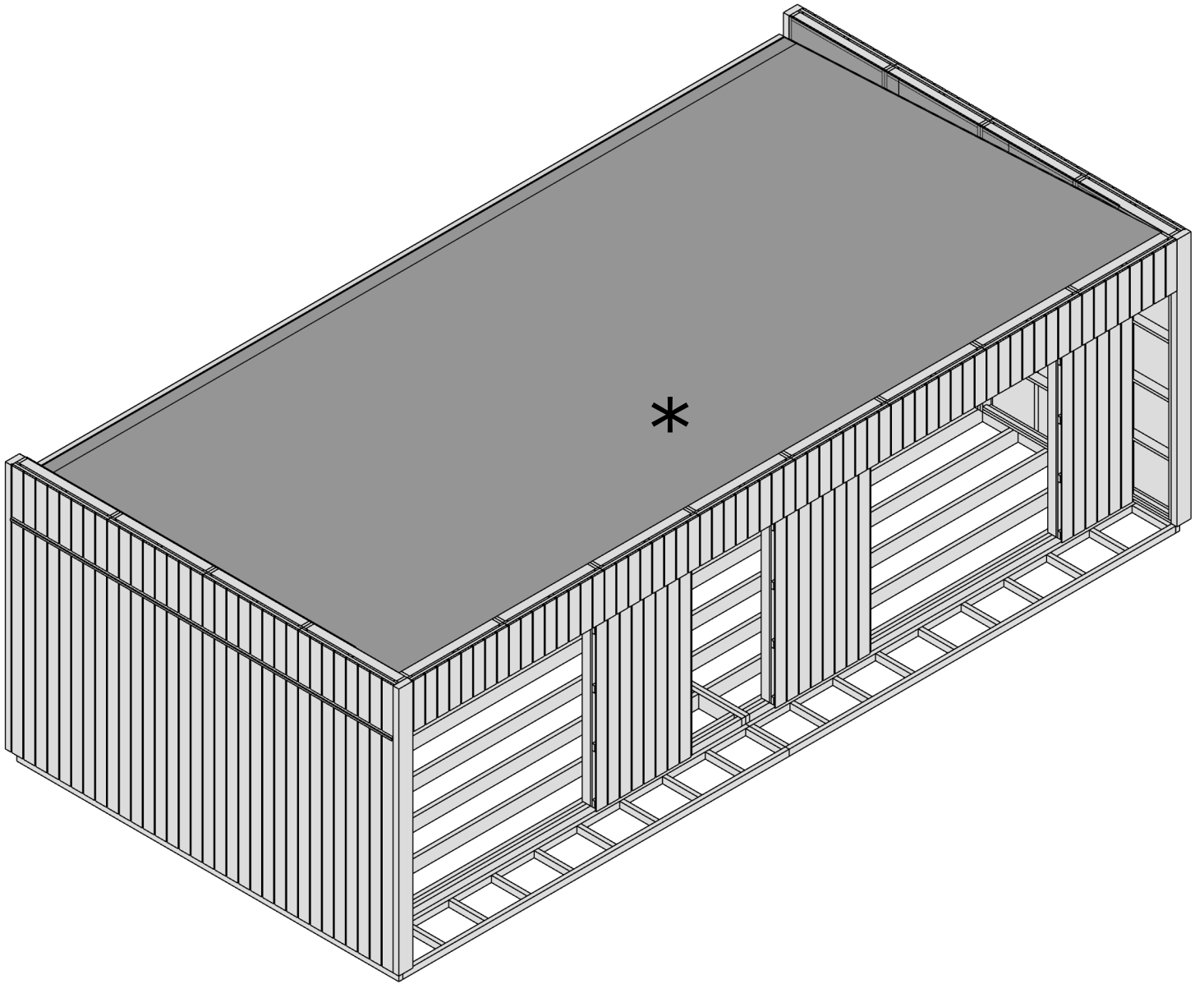

WG7-1 x4  
WG7-2 x4



Ø4,8x28 x58

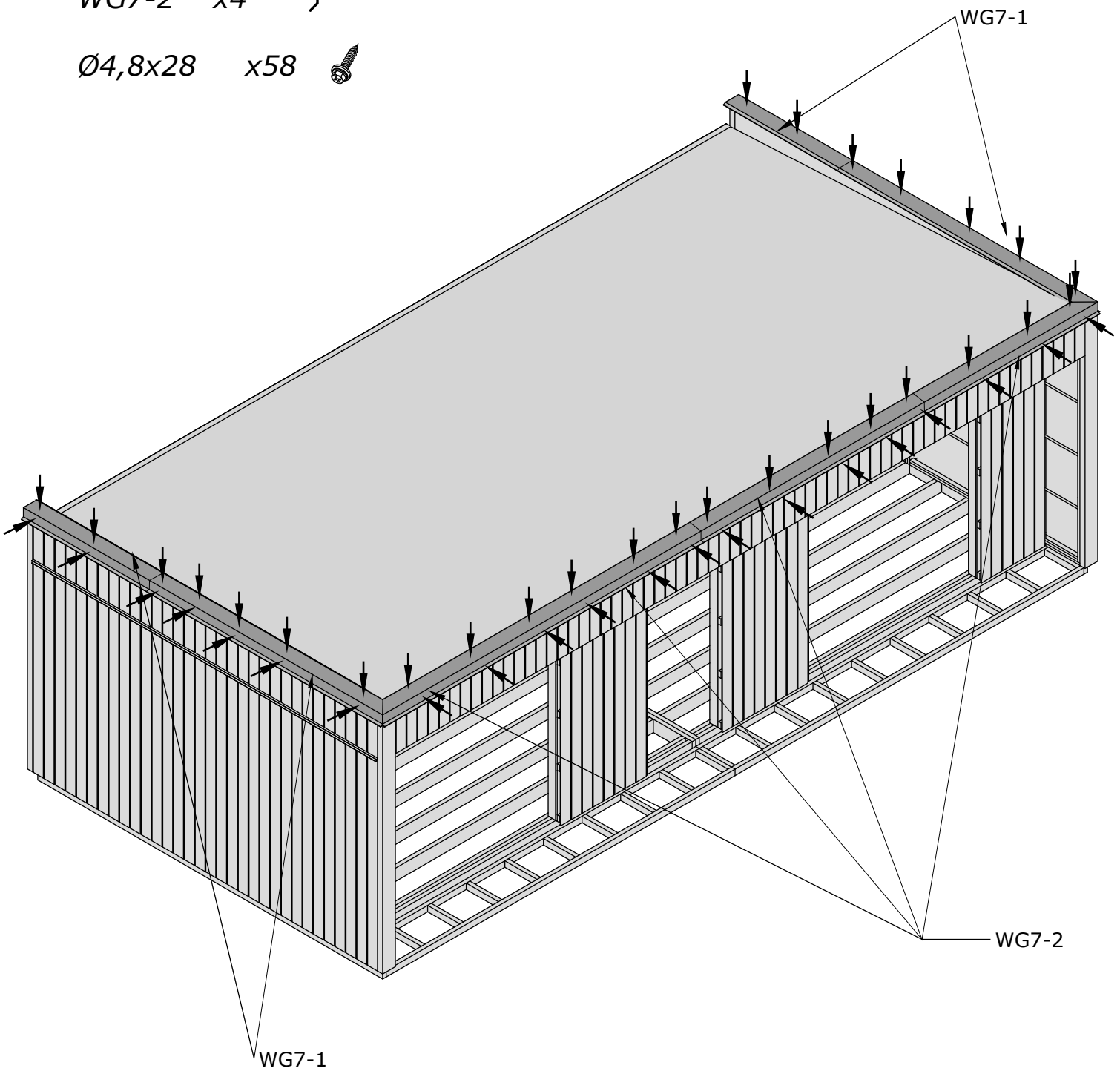

FB5-1 x5  
FB5-2 x5

Ø4,5X60 x110

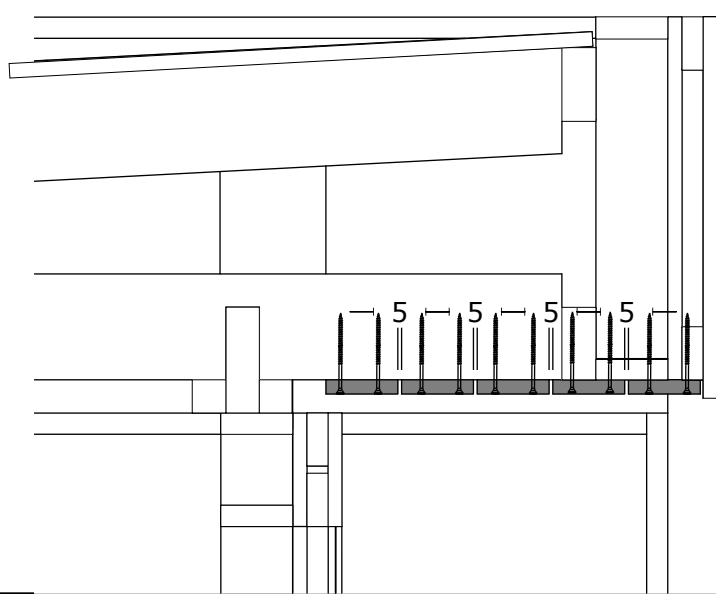
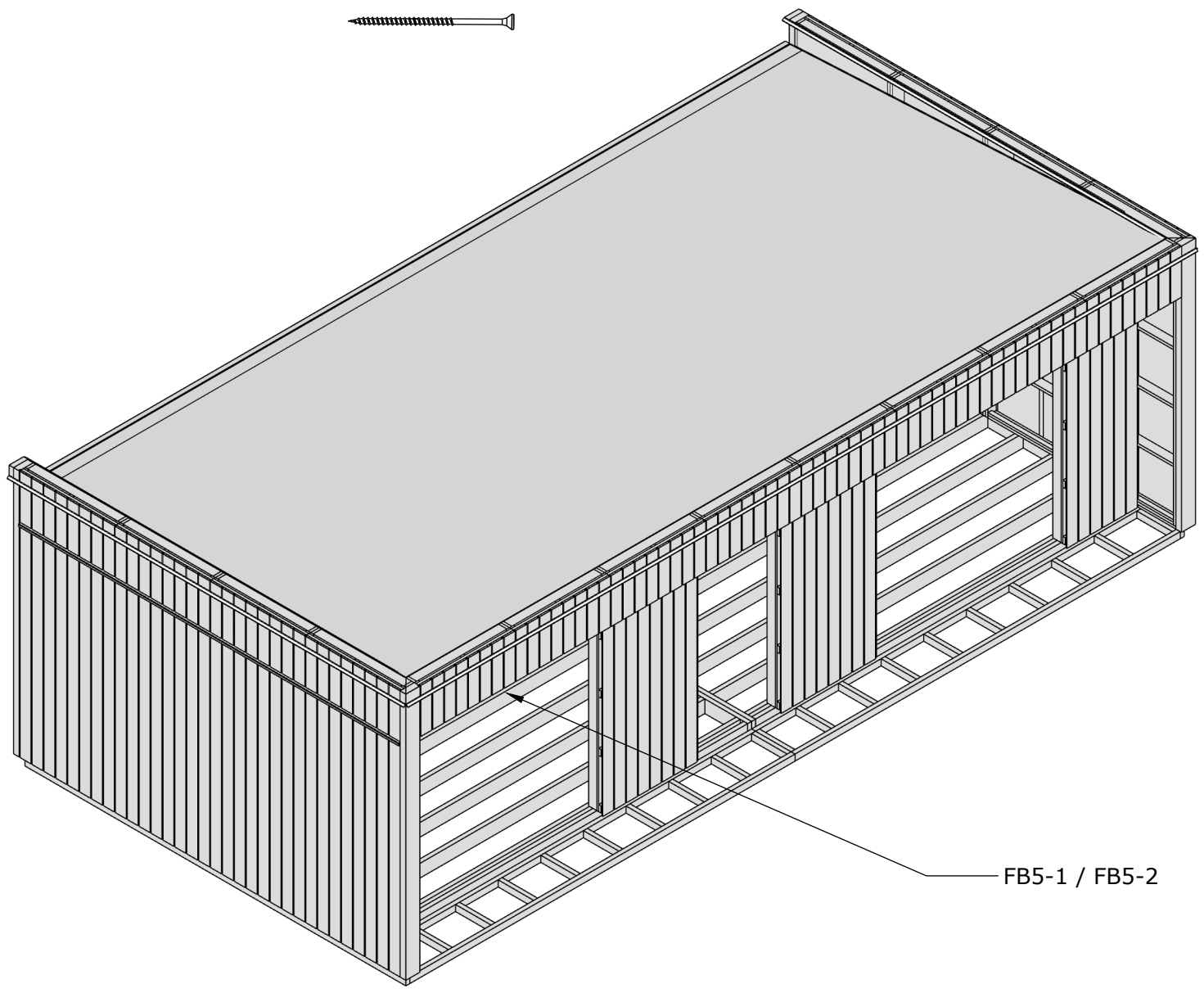
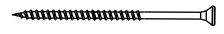

FB2-1 x98

Ø2,5x50 x1200 

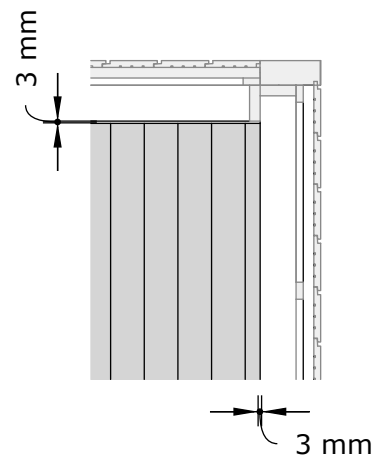
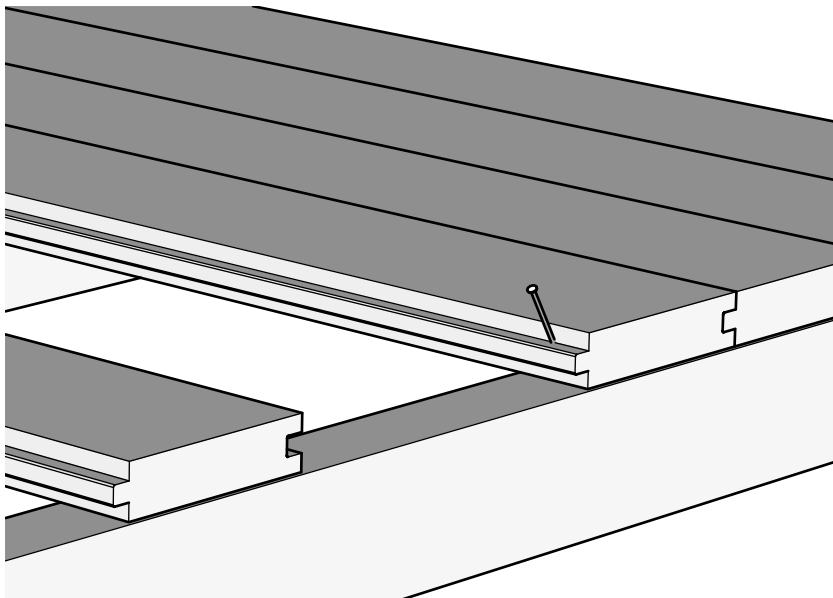
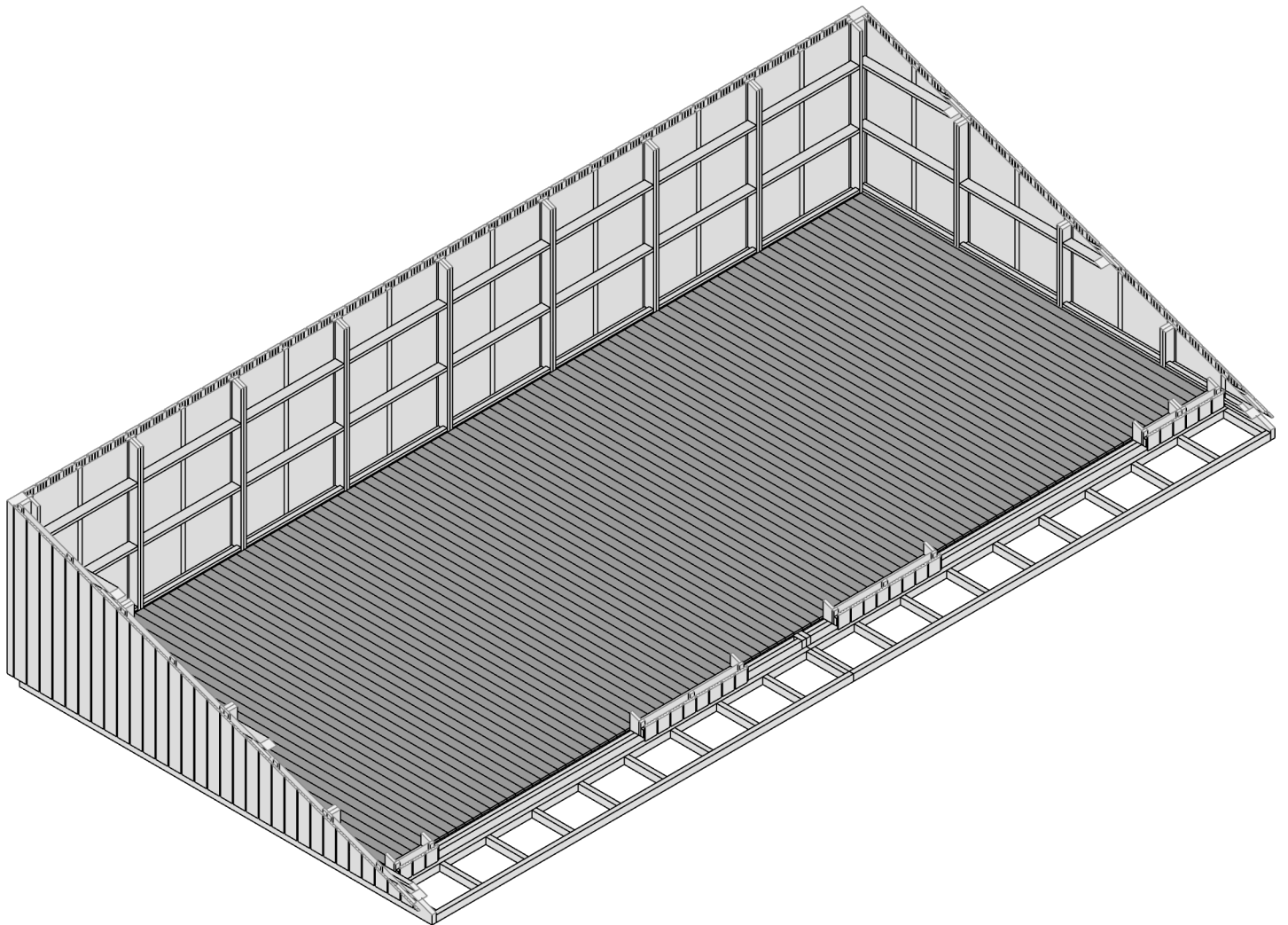
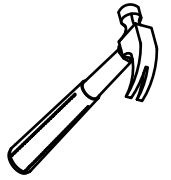

UL4 x2  
UL5 x1

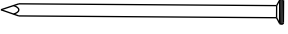
Ø2,5x50 x12 

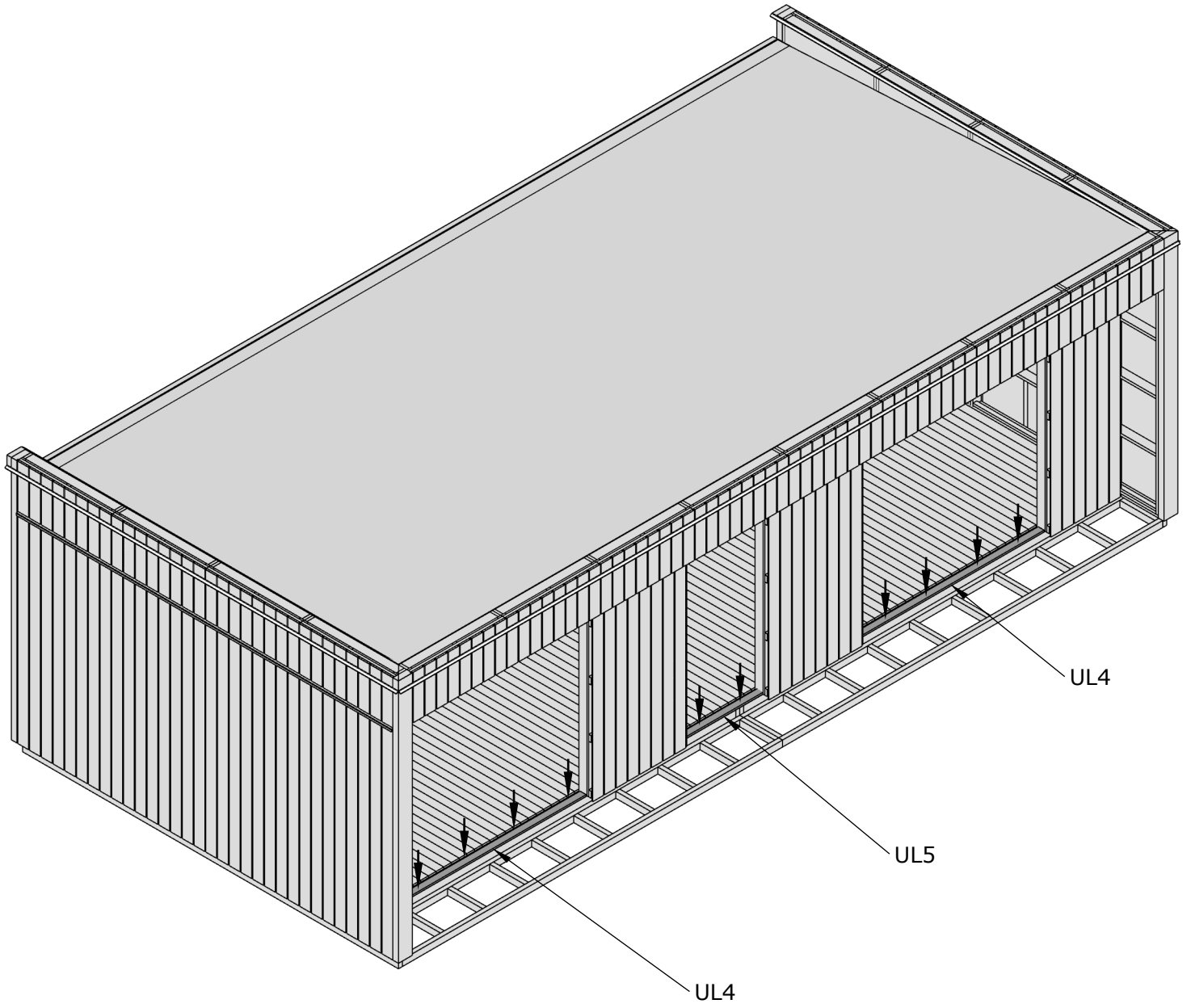
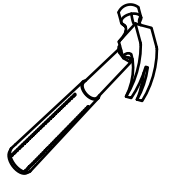

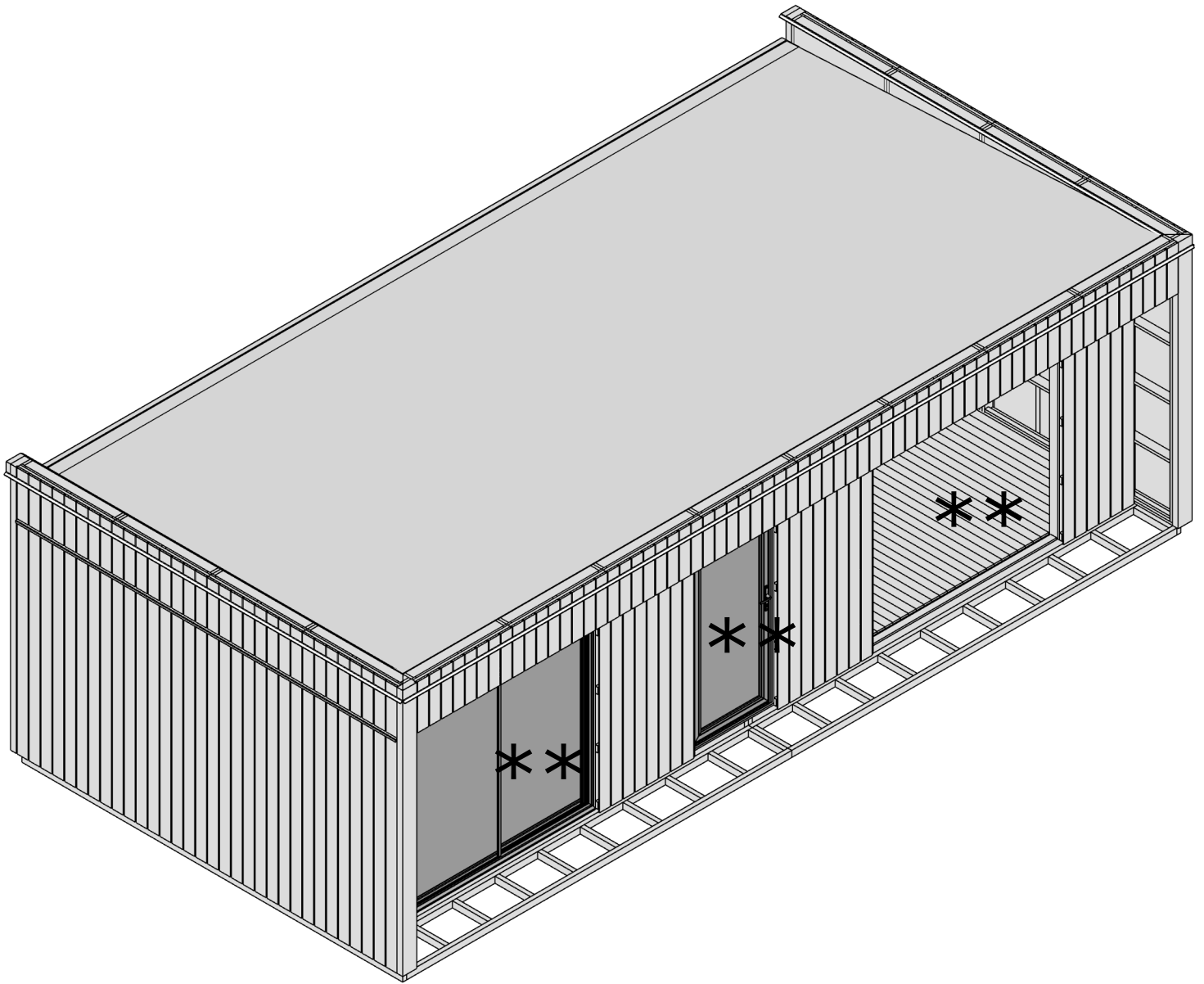

TB2-1 x5  
TB2-2 x5

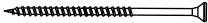
Ø4,5x60 x320 

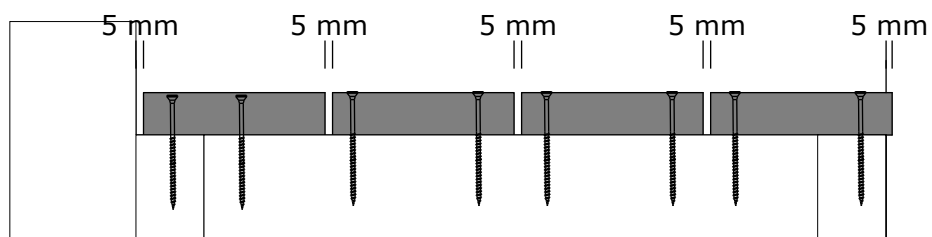
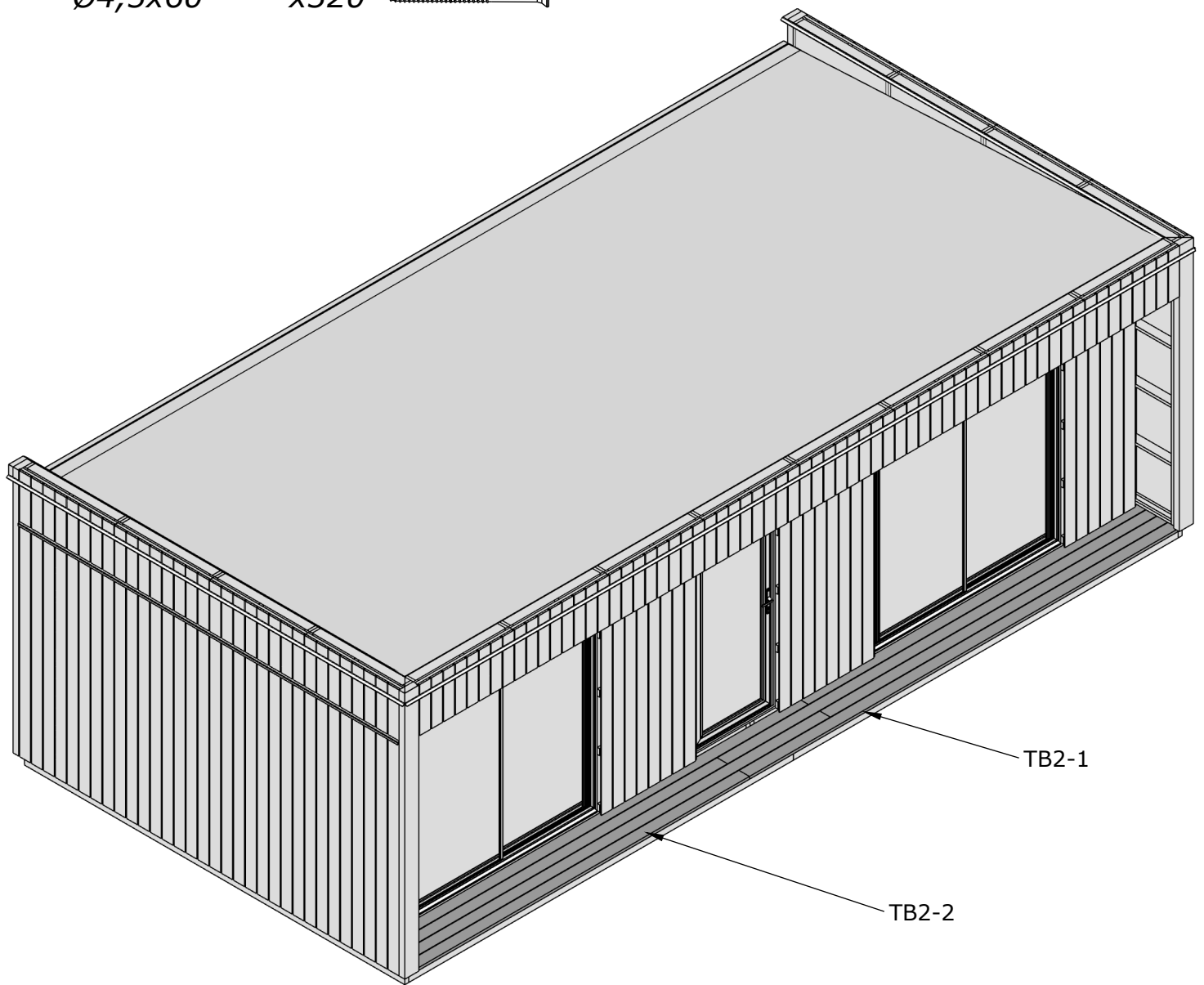

FB5-5 x10

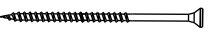
Ø4,5x60 x100 

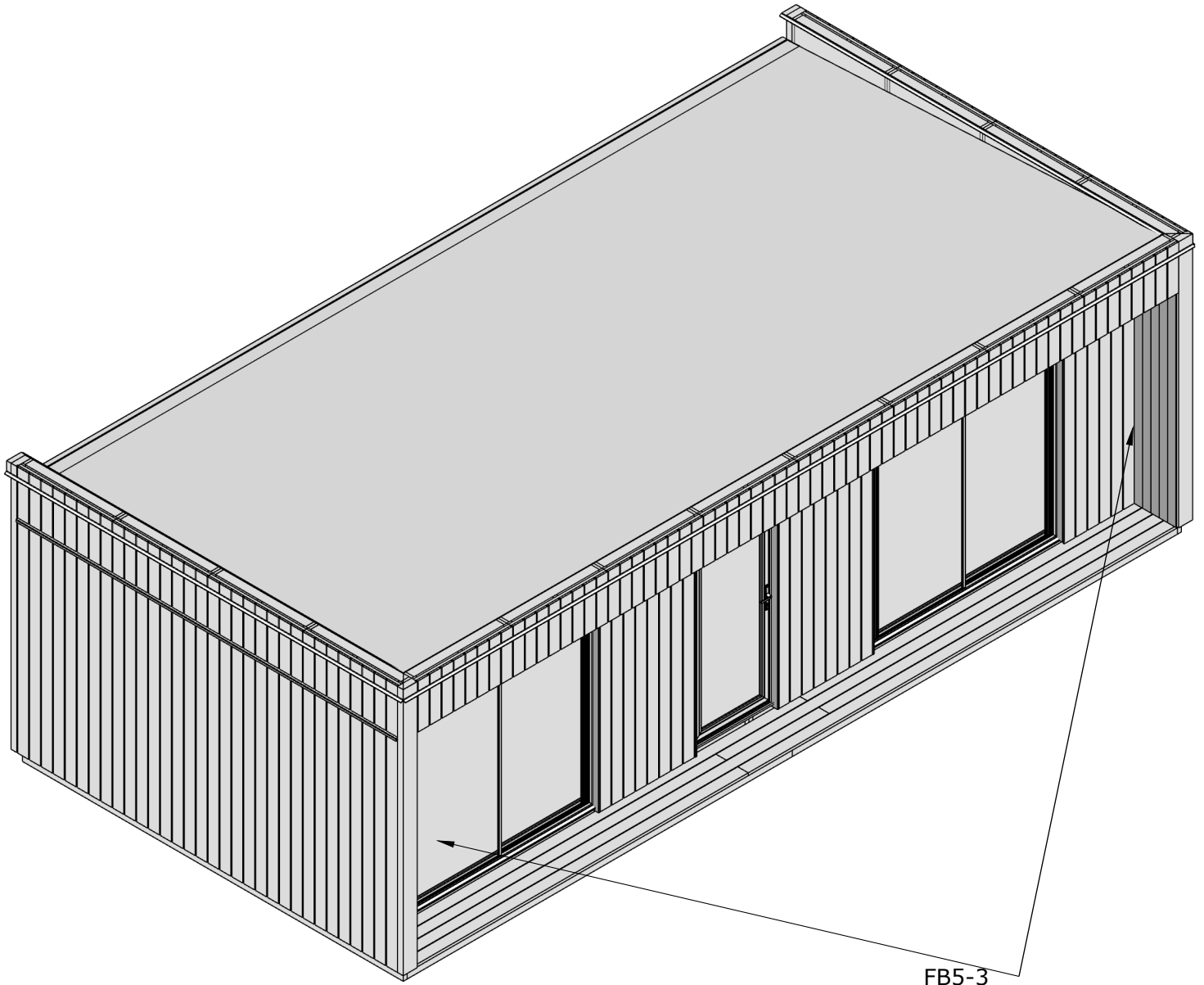
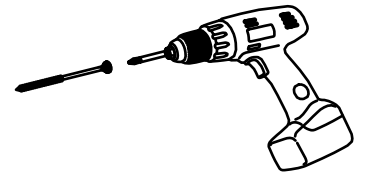

FB5-3

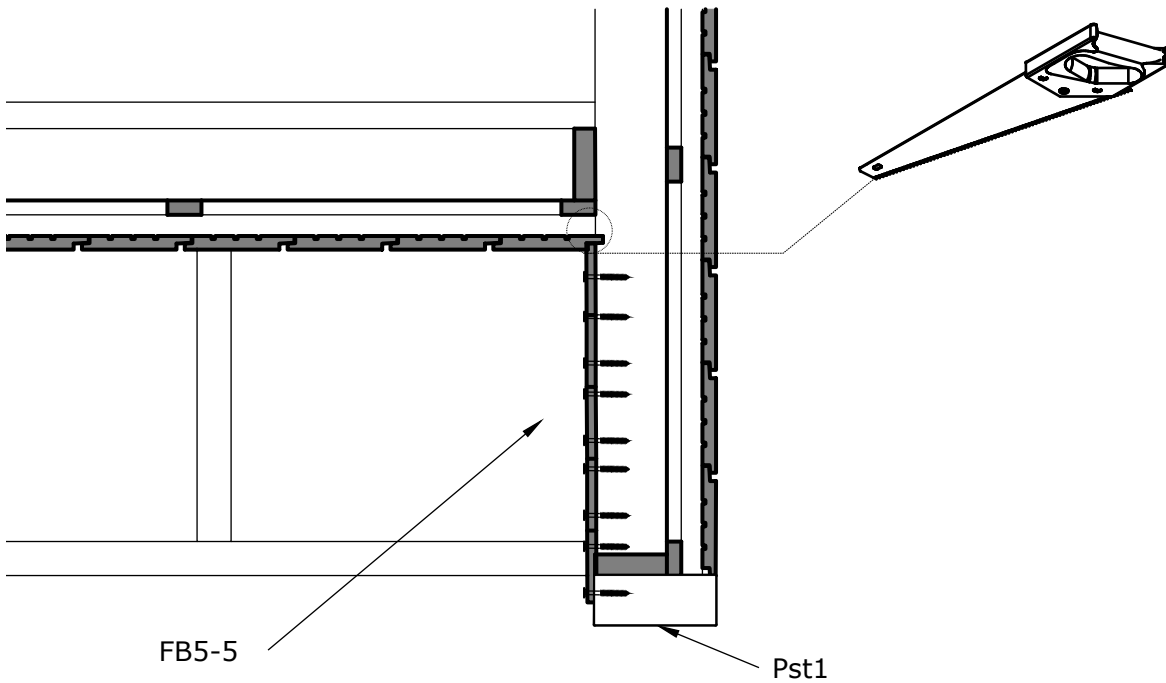

FB5-5

Pst1

UL1 x6

UL2 x1

UL3 x2

Ø4,5x60 x33 