

# Assembly, installation and maintenance manual

Montage-, Aufbau- und Wartungsanleitung • Assemblage, manuel de montage et d'entretien • Montaje, instalación y mantenimiento • Manuale di montaggio, installazione e manutenzione • Monterings- og vedlikeholdsmanual • Monterings-, installations- och underhållsmanual • Kokoamis-, asennus- ja huolto-ohje • Vejledning for montering og vedligehold • Handleiding voor montage, installatie en onderhoud • Manual de montagem, instalação e manutenção • Návod k montáži, instalaci a údržbě • Instrukcja montażu, instalacji i konserwacji • Surinkimo, montavimo ir priežiūros vadovas • Montāžas, uzstādīšanas un apkopes rokasgrāmata • Руководство по сборке и обслуживанию • Montaaži-, paigaldus- ja säilitamise juhend



## Cabin **FR34-4232-7**

<p><b>Factory inspection by</b> • Werkskontrolle durch • Contrôle à partir de l'usine par • Inspector de fábrica • Collaudato da • Fabrikkontroll utført av • Fabriksbesiktigat av • Tehtaan tarkastaja • Fabriks Kontrol udført af • Fabrikscontrole door • Inspeção de fábrica, por: • Zkontrolováno ve výrobním závodě • Kontrola fabryczna do • Apžiūrą gamykloje atliko • Rūpnīcas pārbaudi veicis • Заводской контроль • Tehase kontroll teostatud:</p> <p>.....</p>	<p><b>Date</b> • Datum • Date • Fecha • Data • Dato • Datum • Päiväys • Dato • Datum • Data • Datum • Data • Datums • Data • Дата • Kuupäev:</p>
	<p><b>Pack number</b> • Pack Nr. • Packet n° • Bulto N° • Pacco N. • Serienr • Produktionsnummer • Pakettinro • Pakke nr. • Pak nr. • Número de embalagem • Číslo balení • Numer opakowania • Pakuotės numeris • Iepakojuma numurs • Упаковочный номер • Pakinumber:</p>



[www.palmako.ee/information-hub](http://www.palmako.ee/information-hub)

**English:** Before installing and using the product, please read the instructions and warranty terms at [www.palmako.ee/information-hub](http://www.palmako.ee/information-hub) to guarantee proper installation and long-lasting performance.

**Deutsch:** Wichtig! Bitte vor Aufbau und Nutzung des Produkts unbedingt die detaillierte Montageanleitung sowie die Garantiebedingungen unter [www.palmako.ee/information-hub](http://www.palmako.ee/information-hub) lesen, um eine fachgerechte Montage und eine lange Funktionssicherheit zu gewährleisten.

**Français:** Avant d'installer et d'utiliser le produit, veuillez lire les instructions et les conditions de garantie sur [www.palmako.ee/information-hub](http://www.palmako.ee/information-hub) afin de garantir une installation correcte et la longévité du produit.

**Español:** Antes de instalar y utilizar el producto, lea las instrucciones y las condiciones de garantía en [www.palmako.ee/information-hub](http://www.palmako.ee/information-hub) para asegurar una instalación correcta y una larga vida útil del producto.

**Italiano:** Prima di installare e utilizzare il prodotto, leggere le istruzioni e le condizioni di garanzia su [www.palmako.ee/information-hub](http://www.palmako.ee/information-hub) per garantire una corretta installazione e prestazioni durature.

**Norsk:** Før montering og bruk av produktet, vennligst les monteringsanvisningene og garantivilkårene på [www.palmako.ee/information-hub](http://www.palmako.ee/information-hub) for å sikre korrekt montering og fremtidig holdbarhet.

**Svenska:** Innan du installerar och använder produkten, vänligen läs instruktionerna och garantivillkoren på [www.palmako.ee/information-hub](http://www.palmako.ee/information-hub) för att säkerställa korrekt installation och produktens långvariga hållbarhet

**Suomi:** Ennen tuotteen asentamista ja käyttämistä, lue ohjeet ja takuehdot osoitteessa [www.palmako.ee/information-hub](http://www.palmako.ee/information-hub) varmistaaksesi oikean asennuksen ja pitkäkestoisen toiminnan.

**Русский:** Перед установкой и использованием изделия ознакомьтесь с инструкцией и условиями гарантии на сайте [www.palmako.ee/information-hub](http://www.palmako.ee/information-hub), чтобы гарантировать правильную установку и долговечность изделия.

**Eesti:** Enne toote paigaldamist ja kasutuselevõttu lugege palun juhiseid ja garantiitingimusi aadressil [www.palmako.ee/information-hub](http://www.palmako.ee/information-hub), et tagada nõuetekohane paigaldus ja toote pikk eluiga.

**Dansk (Oversat af AI):** Læs venligst instruktionerne og garantibetingelserne på [www.palmako.ee/information-hub](http://www.palmako.ee/information-hub), før du installerer og bruger produktet, for at garantere korrekt installation og langvarig ydeevne.

**Dutch (Vertaald door AI):** Lees vóór de installatie en het gebruik van het product de instructies en garantievoorwaarden op [www.palmako.ee/information-hub](http://www.palmako.ee/information-hub) om een correcte installatie en langdurige werking te garanderen

**Português (Traduzido por IA):** Antes de instalar e utilizar o produto, leia as instruções e os termos de garantia em [www.palmako.ee/information-hub](http://www.palmako.ee/information-hub) para garantir uma instalação adequada e um desempenho duradouro.





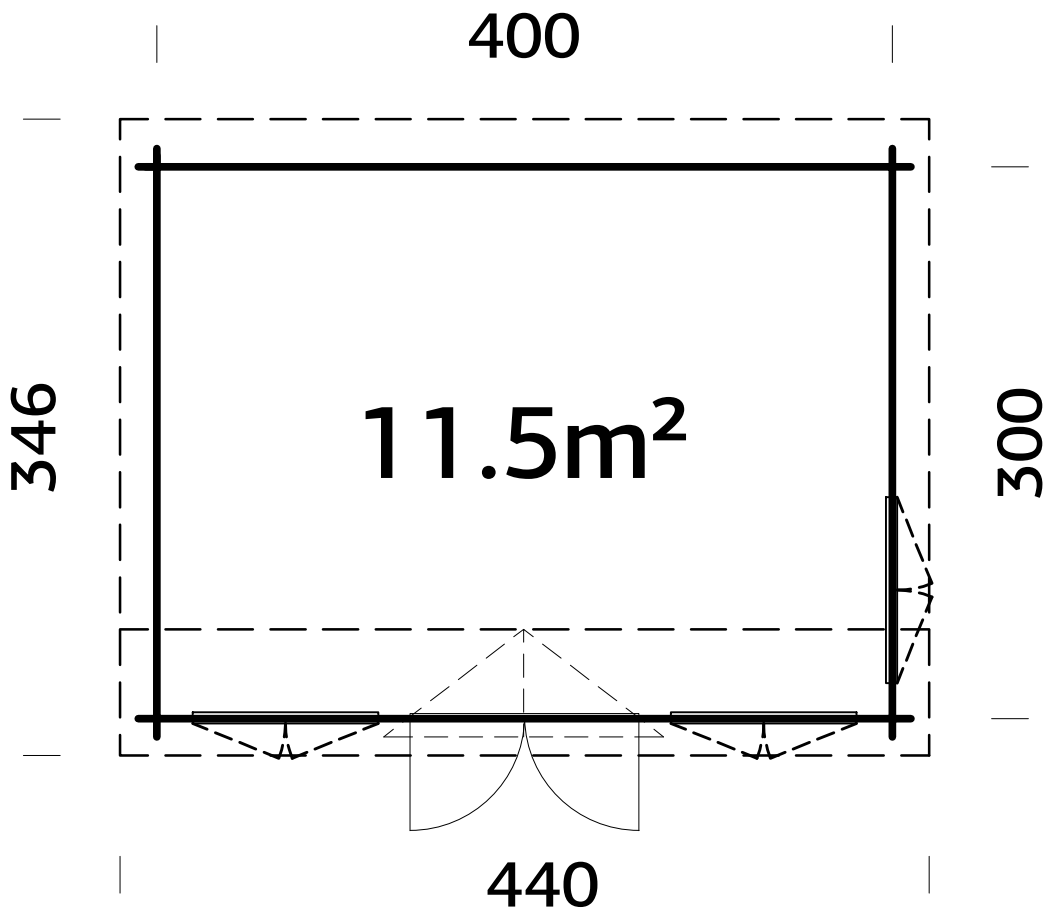

**Čeština (Přeloženo umělou inteligencí):** Před instalací a použitím produktu si prosím přečtěte pokyny a záruční podmínky na [www.palmako.ee/information-hub](http://www.palmako.ee/information-hub), abyste zaručili správnou instalaci a dlouhodobý výkon.

**Polski (Przetłumaczone przez AI):** Przed zainstalowaniem i użyciem produktu należy przeczytać instrukcję oraz warunki gwarancji dostępne na stronie [www.palmako.ee/information-hub](http://www.palmako.ee/information-hub), co pozwoli zagwarantować prawidłową instalację i długotrwałą wydajność.

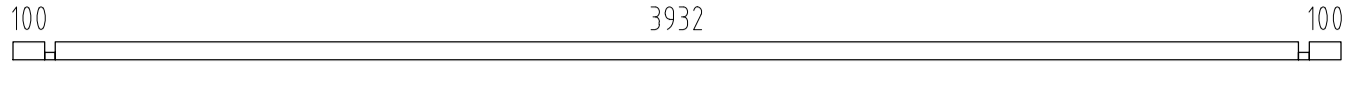
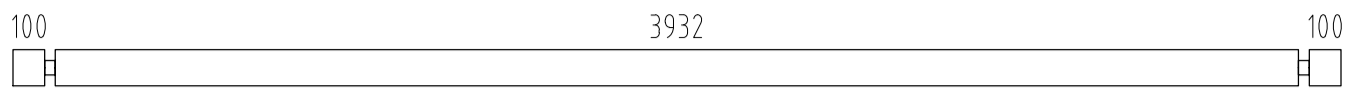
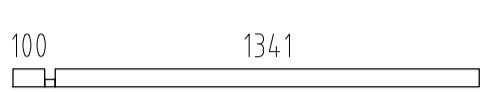
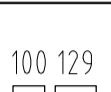

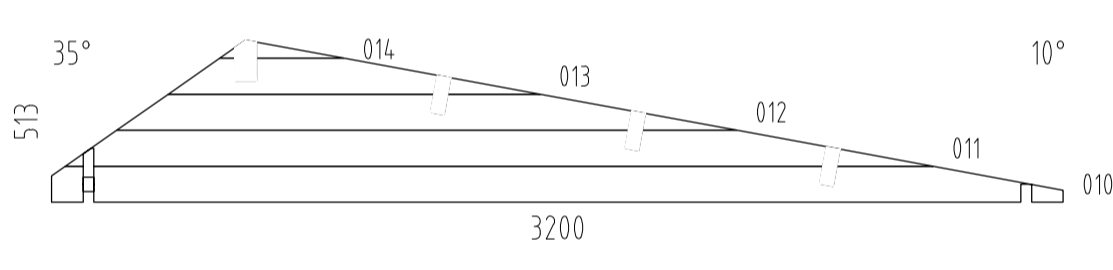
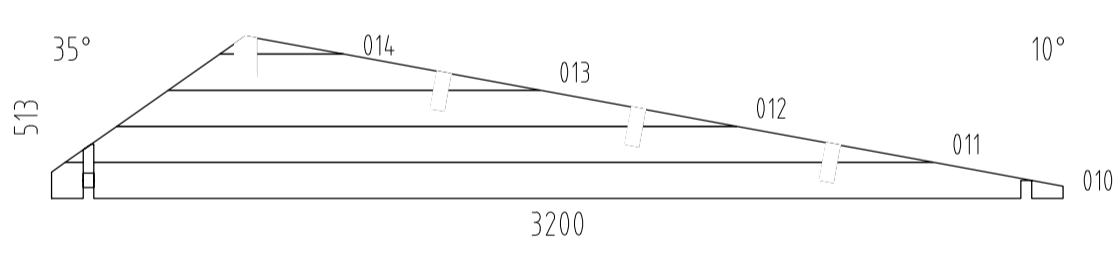
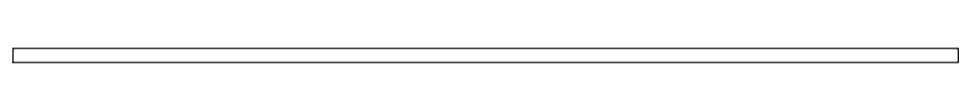
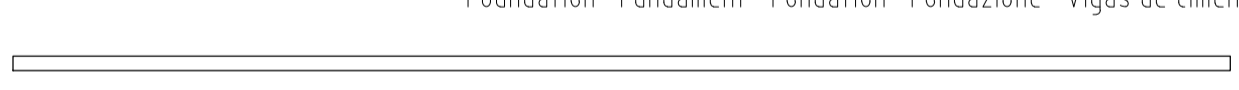

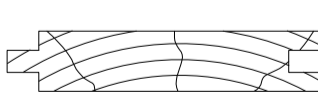

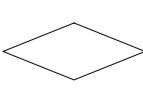

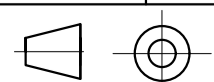

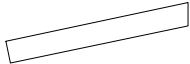

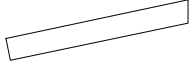
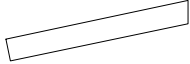







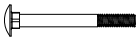
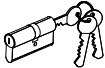

**Latviešu (Mākslīgā intelekta tulkojums):** Pirms produkta uzstādīšanas un lietošanas, lūdzu, izlasiet instrukcijas un garantijas noteikumus vietnē [www.palmako.ee/information-hub](http://www.palmako.ee/information-hub), lai garantētu pareizu uzstādīšanu un ilgstošu darbību.

**Lietuviškai (Išvertė DI):** Prieš montuodami ir naudodami gaminį, perskaitykite instrukcijas ir garantijos sąlygas adresu [www.palmako.ee/information-hub](http://www.palmako.ee/information-hub), kad užtikrintumėte tinkamą montavimą ir ilgalaikį veikimą.









Pos	SPECIFICATION-STÜCKLISTE-NOMENCLATURE-ELEMENTI-ESPECIFICACIÓN FR34-4232-7	Pcs	Profile (mm)	Length (mm)
001		1	34x57	4200
002		17	34x114	4200
003		1	34x114	4400
004		2	34x57	1475
005		8	34x114	1475
006		35	34x114	263
007		24	34x114	202
008		1	34x114	4400
009		21	34x114	3200
015		1	34x114	3200
016		11	34x114	1927
017		1	34x114	3200
WA-1		1		
WB-1		1		
AR1	Foundation- Fundament- Fondation- Fondazione- Vigas de cimentación 	2	70x45	2990
AR2	Foundation- Fundament- Fondation- Fondazione- Vigas de cimentación 	7	70x45	3850
PR1	Purlin- Dachpfette- Arbalétrier- Arcareccio- Correa 	3	44x140	4400
PR2	Purlin- Dachpfette- Arbalétrier- Arcareccio- Correa 	1	70x140	4400
FB2-1	Floor board- Fussbodenbrett- Madrier du plancher - Tavola pavimento- Tabla de suelo 	45	89x19	2926
RB2-1	Roof board- Dachbrett- Madrier du toit- Tavola tetto- Tabla de tejado 	50	89x19	2770
RB2-2	Roof board- Dachbrett- Madrier du toit- Tavola tetto- Tabla de tejado 	50	89x19	835
FLB1-1	Floor beading- Fussbodenleiste- Baguette du plancher- Listello pavimento- Listón de suelo 	8	19x19	1940
Dia-1	Diamond- Deckbrett- Madrier- Tavola di copertura- Rombo 	2	19x140	300

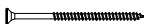

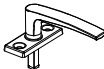
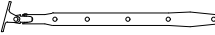
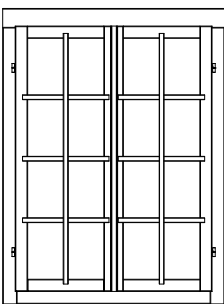
Pos	SPECIFICATION-STÜCKLISTE-NOMENCLATURE-ELEMENTI-ESPECIFICACIÓN FR34-4232-7	Pcs	Profile (mm)	Length (mm)
EaE4-1	Eave edging- Dachrandbrett- Madrier en bordure du toit- Tavola bordo tetto- Tabla de valadizo 	4	19x70	2200
FaB3-1	Facia board- Giebelblende- Écran frontal- Schermo frontone- Tabla de facia 	2	16x120	915
FaB3-2	Facia board- Giebelblende- Écran frontal- Schermo frontone- Tabla de facia 	2	16x120	2850
FaB5-1	Facia board- Giebelblende- Écran frontal- Schermo frontone- Tabla de facia 	1	19x70	1006
FaB5-2	Facia board- Giebelblende- Écran frontal- Schermo frontone- Tabla de facia 	1	19x70	1006
RE2-1	Roof edge reinforcement- Dachrandleiste- Baguette en bordure du toit- Rinforzo bordo tetto- Refuerzo borde tejado 	2	32x40	1900
RE2-2	Roof edge reinforcement- Dachrandleiste- Baguette en bordure du toit- Rinforzo bordo tetto- Refuerzo borde tejado 	2	32x40	2500
QT15_5 x9PR-1	Seal- Gummidichtung- Joint d'isolation- Guarnizione- Burlete- QT15_5x9PR 	1		9600
SlA8-1	Slat- Leiste- Baguette- Listello- Listón 	1	19x35	1250
StB1-1	Storm brace- Sturmleiste- Protection contre le vent- Antivento- Protector contra tormentas 	2	25x45	1950
StB1-2	Storm brace- Sturmleiste- Protection contre le vent- Antivento- Protector contra tormentas 	2	25x45	2050
WG2-1	Water gutter- Wasserleiste- Rejet d'eau- Protección de lluvia- Protezione dalla pioggia- 28x60 	2	28x60	1180
WB1-1	Wind brace- Windbrett- Madrier contre le vent- Tavola vento- Tabla contra el viento 	2	16x45	915
WB1-2	Wind brace- Windbrett- Madrier contre le vent- Tavola vento- Tabla contra el viento 	2	16x45	2850
QPOYP 8x80Zn	Bolt -Schloss-schraube -Boulon- Bullone- Perno- M8x80mm PUP0 	8		
QULSI 30x35	Cylinder- Zylinderschloss- Serrure a mortaiser- Serratura a cilindro- Bombin- 30.35 	1		
QLIU KAPal	Door fittings- Türbeschlag- Ferrure- Ferramenta porta- Manilla puerta- QLIUKAPal 	1		
QRV1 20Zn	Keeper- Schliessblech- Tole- Lamiera- Aldaba de candado- 120Zn 	1		
QNA1 4x40Me	Nail- Nagel- Clou- Chiodo- Clavo- 1.4x40mm 	32		
QNA2 2x50Zn	Nail- Nagel- Clou- Chiodo- Clavo- 2.5x50mm 	700		
QMUK K8Zn	Nut- Schraubenmutter- Écrou- Dado- Tuerca- M8mm 	8		
QKRPP2 _5x16Zn	Screw- Schraube- Vis- Vite- Tornillo- 2.5x16mm Zn 	2		
QKRPP3 _5x35Zn	Screw- Schraube- Vis- Vite- Tornillo- 3.5x35mm 	120		
QKRPP 3x20Zn	Screw- Schraube- Vis- Vite- Tornillo- 3x20mm 	64		
QKRPP4 _5x70Zn	Screw- Schraube- Vis- Vite- Tornillo- 4.5x70mm 	100		

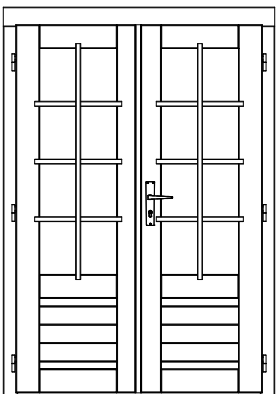

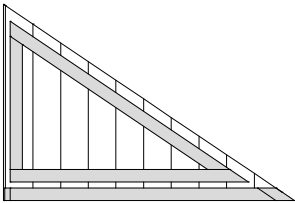
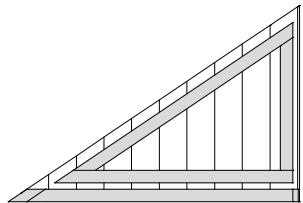
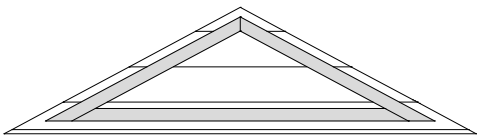
Pos	SPECIFICATION-STÜCKLISTE-NOMENCLATURE-ELEMENTI-ESPECIFICACIÓN FR34-4232-7	Pcs	Profile (mm)	Length (mm)
QKRPP 5x90Zn	Screw- Schraube- Vis- Vite- Tornillo- 5x90mm		16	
QKRPP 6x160 ZnTX-1	Screw- Schraube- Vis- Vite- Tornillo- 6x160mm TX-1		30	
QSE8 x22Zn	Washer- Dichtscheibe- Joint- Rondella- Arandela- 8x22mm		8	
QLIA	Window fittings- Fenstergriff- Poigne de la fenetre- Maniglia finestra- Manilla (ventana)		6	
QFK2 40Zn	Window stop- Fensterfeststelle- Crémaillere- Fissativo finestra- Fijador de ventana- QFK240Zn		6	
TA34 -21P	Window - Fenster - Fenetre - Finestra-Ventana 1003x1336    903x1236mm		3	
TU34 -66P	Door - Tür - Porte - Porta-Puerta 1244x1822    1144x1753mm  G+		1	
KE630-V	Roof element- Dachelement- Panneau de toit- Elemento di tetto- Elemento tejado -1  		1	51x631 937
KE630-P	Roof element- Dachelement- Panneau de toit- Elemento di tetto- Elemento tejado -2  		1	51x631 937
KK4-1518 -19-1	Roof element- Dachelement- Panneau de toit- Elemento di tetto- Elemento tejado -3  		1	51x406 1518

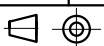

	AR2	
	AR2	
	AR2	
	AR2	
AR1	AR2	AR1
	AR2	
	AR2	
	AR2	
	AR2	

H = 1.500 m  
TOTAL: 11.53 m<sup>2</sup>

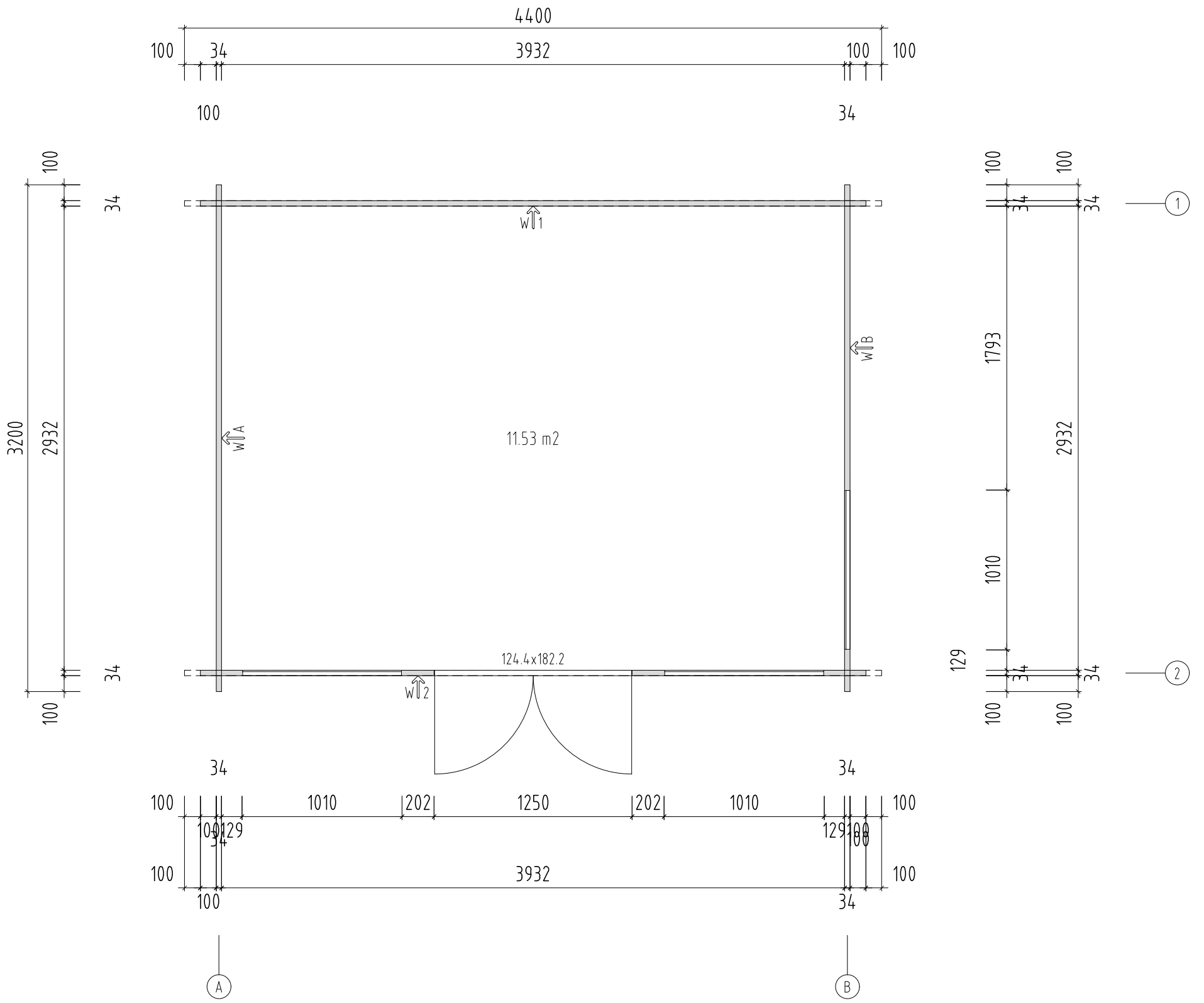

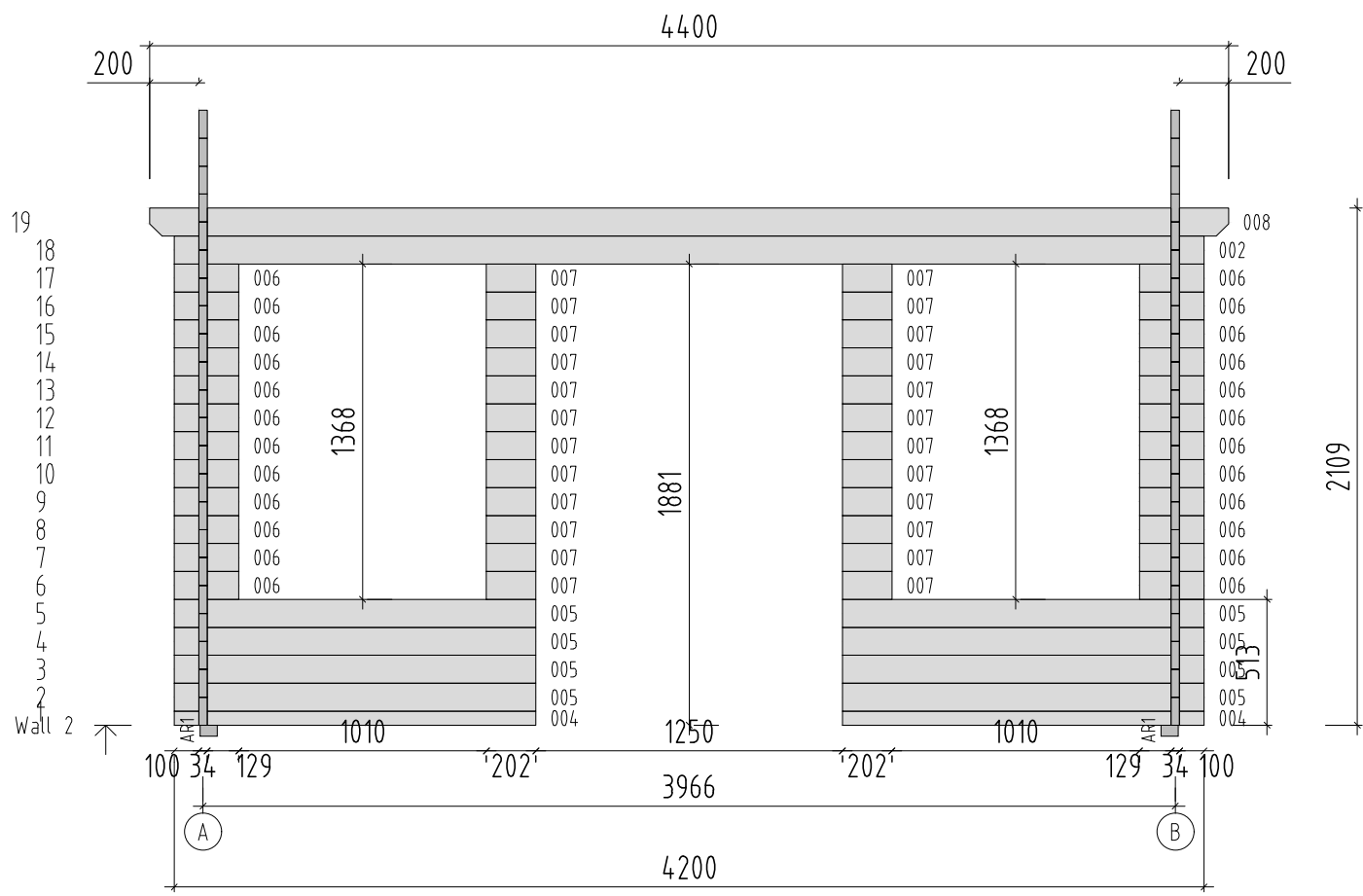

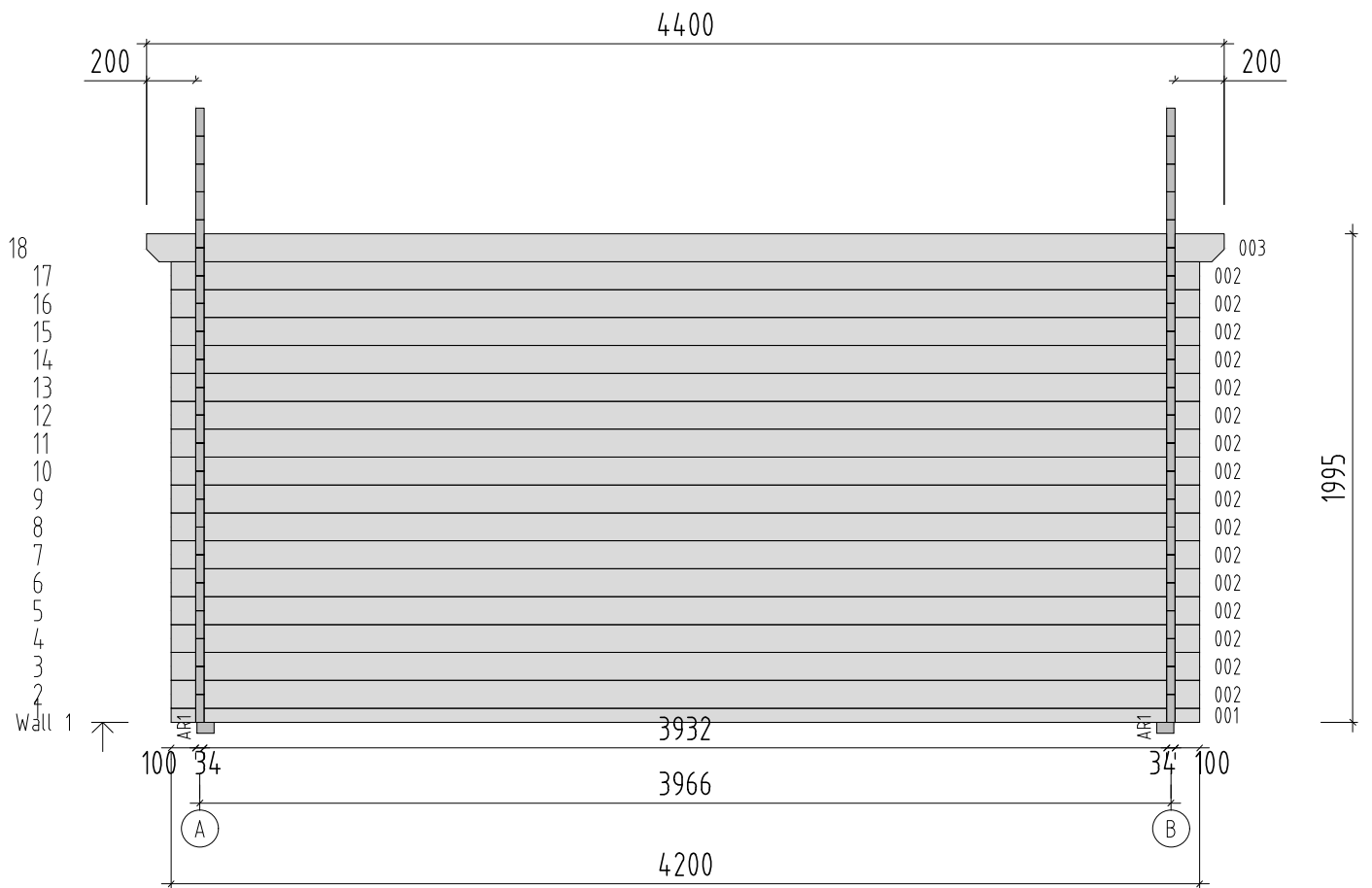

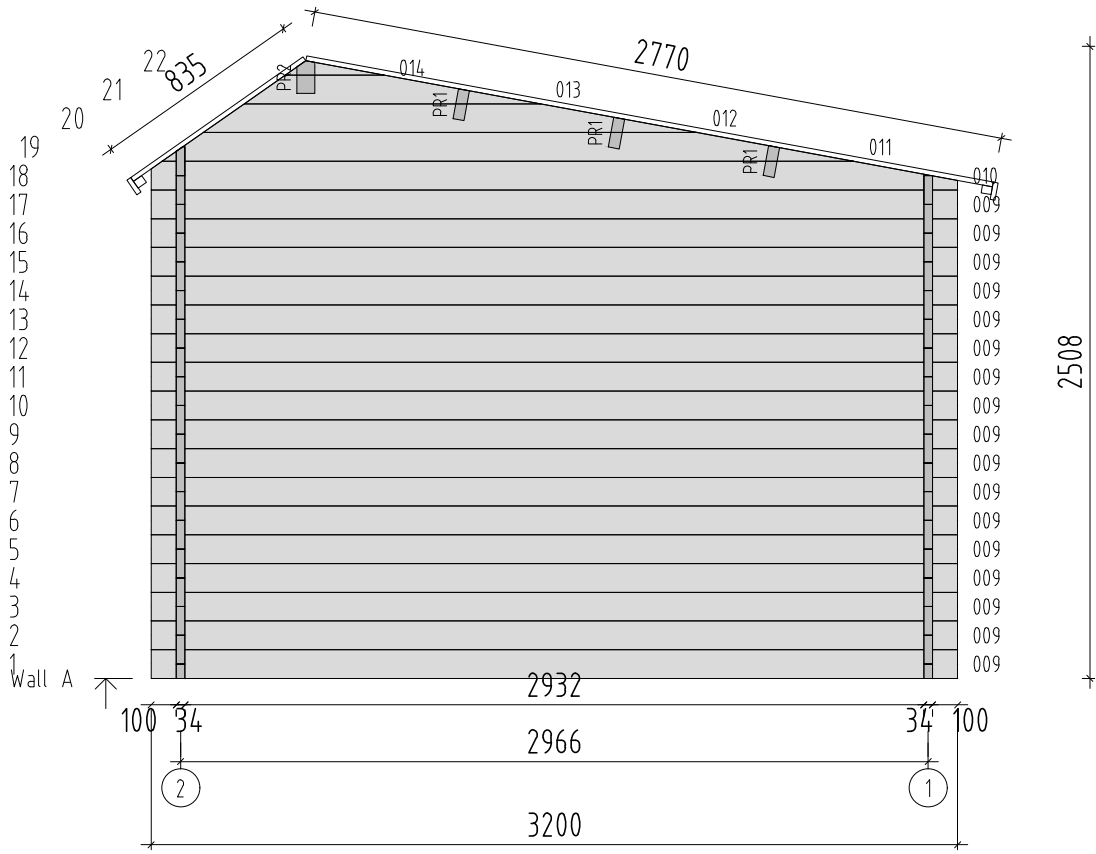



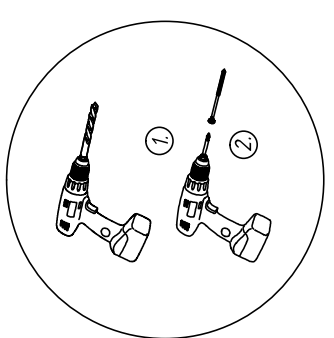
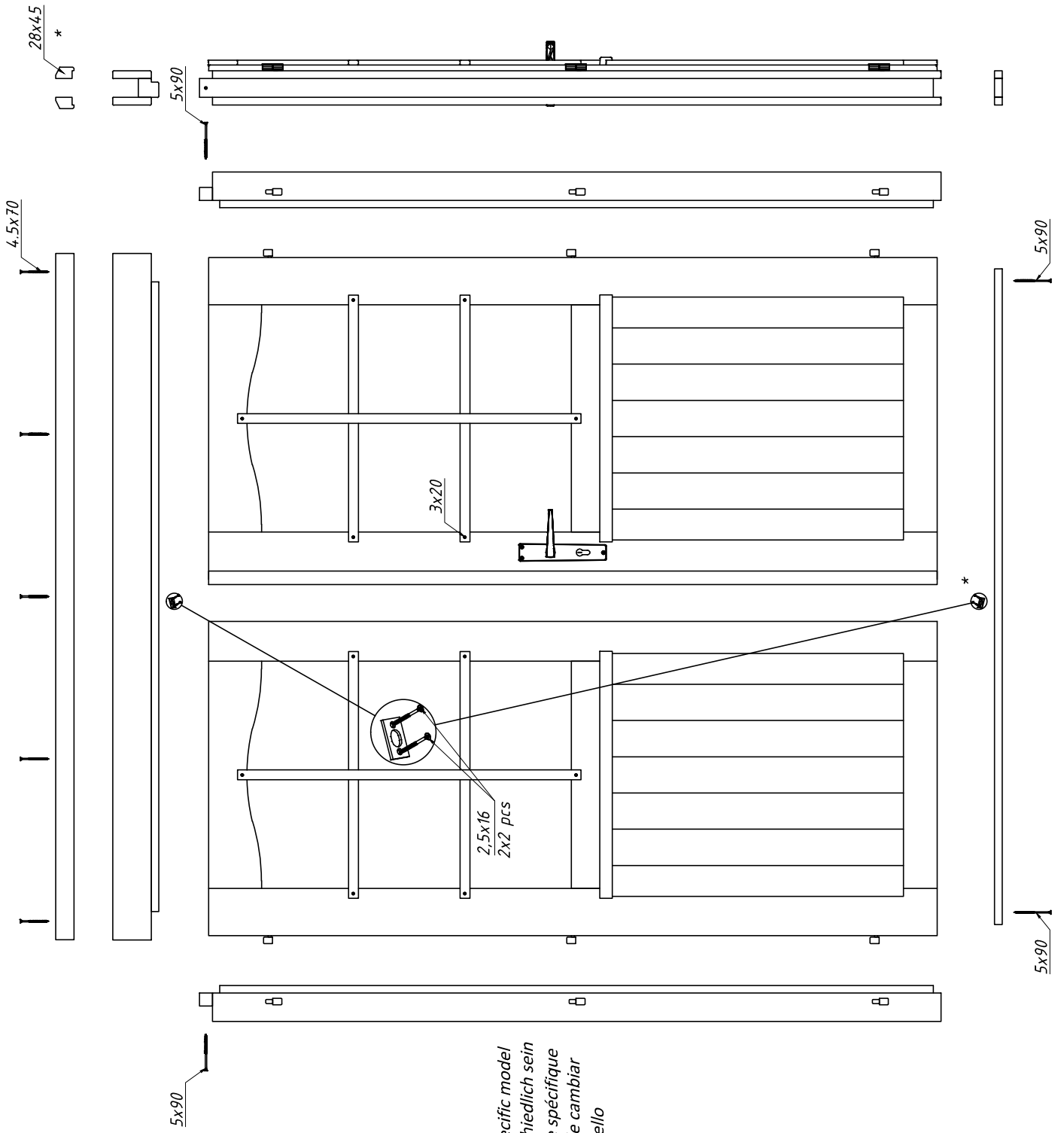

\* The specification may vary depending on the specific model  
 \* Die Spezifikation können je nach Modell unterschiedlich sein  
 \* Les spécifications peuvent varier selon le modèle spécifique  
 \* Dependiendo del modelo, la especificación puede cambiar  
 \* Le specifiche possono variare a seconda del modello

1.

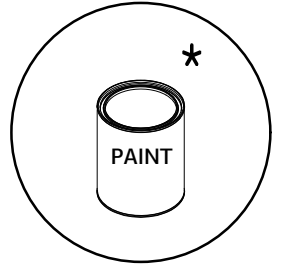
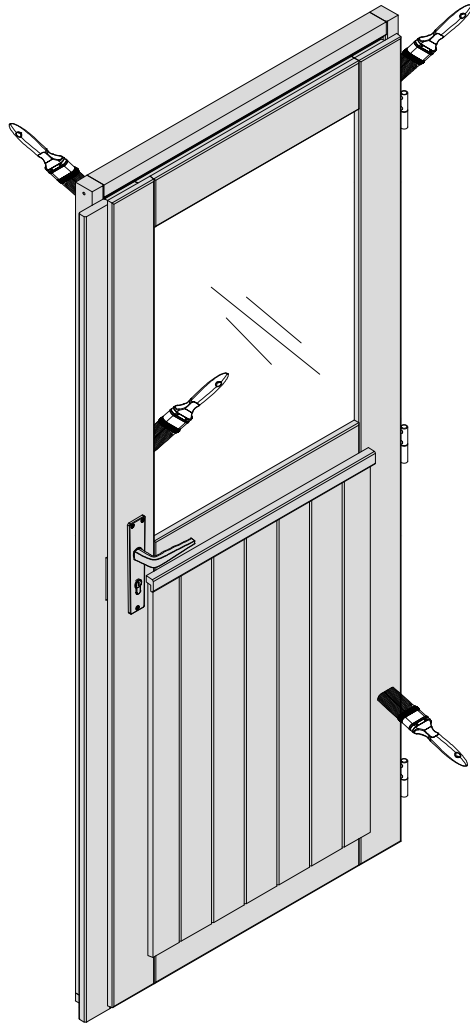
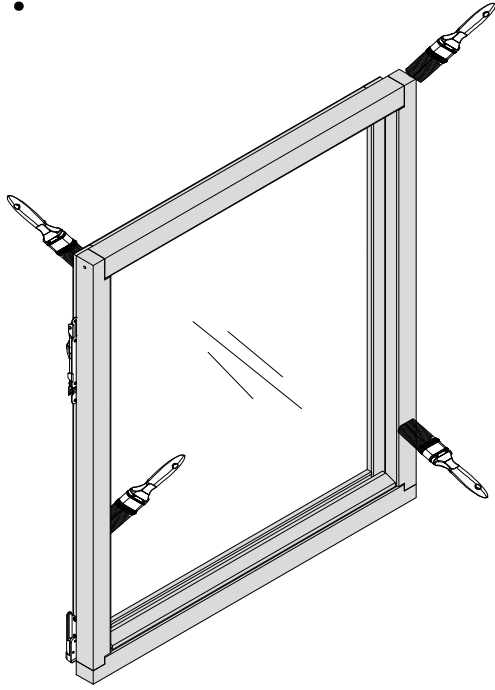

2.

