

60360 + 60361

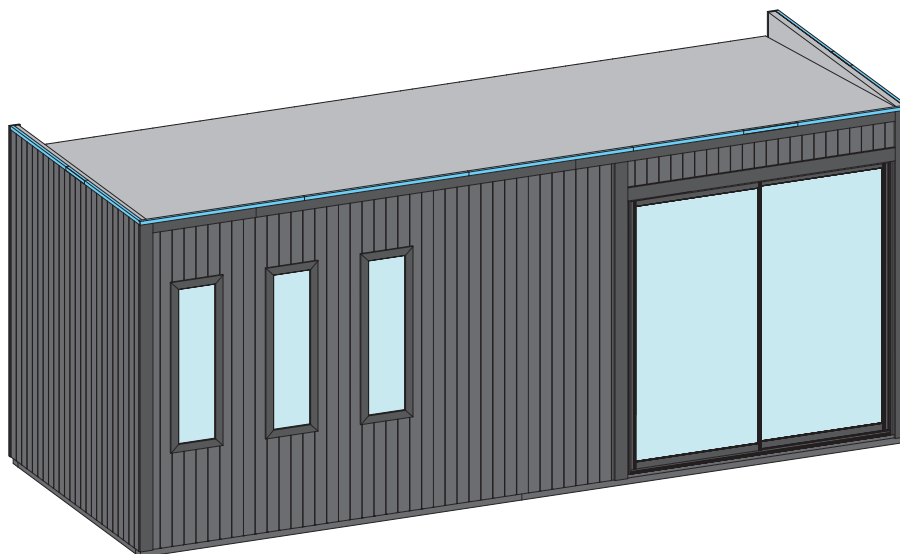

 **Aufbauanleitung**

 **Building Instructions**

 **Notice de montage**

 **Montagehandleiding**

 **Montagevejledning**

 **Instrucciones de construcción**

 **Istruzioni per il montaggio**

 **Montážní návod**

 **Montážny návod**

 **Navodila za sestavljanje**

 **Instrukcja montażu**



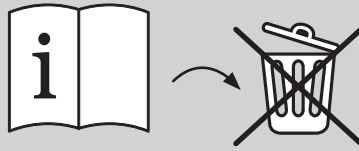

Bitte bewahren Sie die Anleitung und den Garantieschein zur Seriennummer auf. Vernichten Sie diese erst nach Ablauf der Garantiezeit. Eventuelle Beanstandungen können mithilfe der Stückliste einfacher zugeordnet werden.

Beigelegte Dokumente

• Informationsheft • Garantieschein zur Seriennummer • Typenschild inkl. Warnhinweise (Sauna) • ggf. Zubehör-Anleitungen in ext. Paketen

 Please keep the instructions and warranty certificate with the serial number. Only destroy these after the warranty period has expired. Any complaints can be more easily traced with the help of the parts list.

Enclosed documents:

- Information booklet
- Warranty certificate for the serial number
- Type plate including warning notices (sauna)
- Accessory instructions in external packages, if applicable

 Veuillez conserver le mode d'emploi et le certificat de garantie avec le numéro de série. Ne les détruisez qu'après expiration de la période de garantie. Les éventuelles réclamations peuvent être traitées plus facilement à l'aide de la liste des pièces.

Documents joints :

- Brochure d'information
- Certificat de garantie avec numéro de série
- Plaque signalétique avec avertissements (sauna)
- Le cas échéant, notices d'utilisation des accessoires dans des emballages séparés

 Bewaar de handleiding en het garantiebewijs met serienummer. Vernietig deze pas na afloop van de garantieperiode. Eventuele klachten kunnen met behulp van de stuklijst gemakkelijker worden toegewezen.

Bijgevoegde documenten:

- Informatieboekje
- Garantiebewijs met serienummer
- Typeplaatje incl. waarschuwingen (sauna)
- Eventueel handleidingen voor accessoires in externe pakketten

 Opbevar venligst vejledning og garantibeviset med serienummeret. Destruer dem først efter garantiperiodens udløb. Eventuelle reklamationer kan lettere henføres til ved hjælp af styklisten.

Vedlagte dokumenter:

- Informationshæfte
- Garantibevis med serienummer
- Typeskilt inkl. advarsler (sauna)
- Eventuelle tilbehørsvejledninger i eksterne pakker

 Conserve el manual de instrucciones y el certificado de garantía con el número de serie. No los destruya hasta que haya expirado el periodo de garantía. Las posibles reclamaciones se pueden asignar más fácilmente con ayuda de la lista de piezas.

Documentos adjuntos:

- Folleto informativo
- Certificado de garantía con el número de serie
- Placa de características con advertencias (sauna)
- En su caso, instrucciones de los accesorios en paquetes externos

 Conservare le istruzioni e il certificato di garanzia con il numero di serie. Distruggerli solo dopo la scadenza del periodo di garanzia. Eventuali reclami possono essere gestiti più facilmente con l'aiuto della lista dei componenti.

Documenti allegati:

- Opuscolo informativo
- Certificato di garanzia con numero di serie
- Targhetta identificativa con avvertenze (sauna)
- Eventuali istruzioni per gli accessori in confezioni separate

 Uschovejte si návod k použití a záruční list se sériovým číslem. Zničte je až po uplynutí záruční doby. Případné reklamace lze snadněji přiřadit pomocí seznamu dílů.

Přiložené dokumenty:

- Informační brožura
- Záruční list k sériovému číslu
- Typový štítek včetně varovných upozornění (sauna)
- Případně návody k příslušenství v externích baleních

 Uložte si návod a záruční list so sériovým číslom. Zničte ich až po uplynutí záručnej doby. Prípadné reklamácie sa dajú jednoduchšie priradiť pomocou zoznamu dielov.

Priložené dokumenty:

- Informačná brožúra
- Záručný list k sériovému číslu
- Typový štítok vrátane varovných upozornení (sauna)
- prípadne návody k príslušenstvu v externých baleniach

 Shranite navodila in garancijski list s serijsko številko. Uničite jih šele po izteku garancijske dobe. Morebitne reklamacije je lažje dodeliti s pomočjo seznama delov.







Priloženi dokumenti:

- Informativna brošura
- Garancijski list za serijsko številko
- Tipska ploščica z opozorili (savna)
- Po potrebi navodila za dodatno opremo v zunanjih paketih

 Proszę zachować instrukcję obsługi i kartę gwarancyjną z numerem seryjnym. Należy je zniszczyć dopiero po upływie okresu gwarancji. Ewentualne reklamacje można łatwiej przyporządkować za pomocą listy części.

Dolączone dokumenty:

- Broszura informacyjna
- Karta gwarancyjna z numerem seryjnym
- Tabliczka znamionowa wraz z ostrzeżeniami (sauna)
- W razie potrzeby instrukcje obsługi akcesoriów w dodatkowych opakowaniach

-  Nicht im Lieferumfang enthalten
-  Not included
-  Non comprises dans la livraison
-  Niet bijgeleverd
-  Ikke inkluderet
-  No forman parte del suministro
-  Non incluso
-  Není součástí dodávky
-  Nie je súčasťou dodávky
-  Ni vključeno v obseg dobave
-  Nie wchodzi w skład dostawy









2

-  Nicht gebraucht
-  Not needed
-  Pas nécessaire
-  Niet nodig
-  Ikke nødvendigt
-  No es necesario
-  Non necessario
-  Nepotřebné
-  Nepoužívané
-  Ne uporablja se
-  Niepotrzebne











4

-  Fixiert vorübergehend
-  Fixed temporarily
-  Temporairement fixe
-  Tijdelijk vast
-  Midlertidigt rettet
-  Temporalmente fijo
-  Temporaneamente fisso
-  Dočasně fixováno
-  Dočasne fixované
-  Začasno popravi
-  Tymczasowo ustalone

6

-  Nicht in allen Varianten gebraucht
-  Not used in all variants
-  Pas nécessaire dans toutes les variantes
-  Niet in alle varianten nodig
-  No se utiliza en todas las variantes.
-  Non necessario in tutte le varianti
-  Nepoužívá se ve všech variantách
-  Ikke brugt i alle varianter
-  Ni potrebno v vseh različicah

1

-  Länge muss ermittelt und zugesägt werden
-  Length must be determined and sawn
-  La longueur doit être déterminée et sciée
-  De lengte moet worden bepaald en worden gezaagd
-  Længden skal bestemmes og saves
-  La longitud debe ser determinada y aserrada
-  La lunghezza deve essere determinata e segata
-  Délka musí být určena a rozřezána
-  Dĺžka sa musí zistiť a odrezať.
-  Določiti je treba dolžino in jo odrezati po velikosti.
-  Należy określić długość i przyciąć.

3

-  Mit Zubehör
-  With accessories
-  Avec accessoires
-  Met toebehoren
-  Med tilbehør
-  Con accesorios
-  Con accessori
-  S příslušenstvím
-  S príslušenstvom
-  Z dodatki
-  Z akcesoriami

5

-  Bestand vom Haus
-  Inventory of the house
-  Inventaire de la maison
-  Inventaris van het huis
-  Inventar af huset
-  Inventario de la casa
-  Inventario della casa
-  Inventář domu
-  Zásoby domu
-  Inventarizacija hiše
-  Stan domu

 Vergleichen Sie zuerst die Materialliste mit Ihrem Paketinhalt! Bitte haben Sie Verständnis, dass Beanstandungen nur im nicht aufgebauten Zustand bearbeitet werden können!

 First compare the list of materials with your package contents! Please understand that complaints can be processed in the non-built status only!

 Commencez par comparer la liste du matériel avec le contenu de votre paquet! Sachez que nous traitons uniquement les réclamations concernant le matériel à l'état non monté!

 Vergelijk eerst de lijst van materialen met de inhoud van uw pakket! Reclamaties kunnen alleen in behandeling worden genomen zolang de onderdelen nog niet zijn gemonteerd!

 Start med at kontrollere materialelisten med indholdet af den leverede pakke! Vi gør venligst opmærksom på at reklamationer kun kan behandles for materialer som ikke er blevet bearbejdet!

 En primer lugar, compare la lista de material con el contenido del paquete. Rogamos entienda que las reclamaciones sólo pueden ser tramitadas antes de montar el objeto!

 Confrontate questa distinta materiali prima con il contenuto del pacchetto! Vi preghiamo di comprendere che eventuali reclami possono essere accolti solo prima del montaggio!

 Nejprve překontrolujte obsah balení podle materiálového listu! Mějte pochopení pro to, že případnou reklamaci se můžeme zabývat pouze

tehdy, když díly nebudou smontované! Za pomoci tohoto seznamu můžete jednotlivé díly přiřadit k montážnímu návodu.



 Najprv porovnajzte zoznam materiálu s obsahom balíka! Prosíme, majte na pamäti, že reklamácie môžu byť spracované iba v prípade, ak produkt nie je zmontovaný!

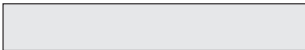

 Najprej primerjajte seznam materialov z vsebino vašega paketa! Upoštevajte, da lahko pritožbe obravnavamo le v nesestavljenem stanju!

 Najpierw porównaj listę materiałów z zawartością paczki! Prosimy o wyrozumiałość, że reklamacje mogą być rozpatrywane tylko w przypadku produktów, które nie zostały jeszcze zmontowane!





	
15x B 1	2380 x 4 x 16 mm ID 92932
3 x B 2	2000 x 36 x 12 mm ID 35341
2x B 3	1930 x 25 x 18 mm ID 63576
1 x B 4	2100 x 25 x 18 mm ID 35324
2 x B 5	2100 x 45 x 18 mm ID 19547
2 x B 6	2000 x 58 x 18 mm ID 63572
1 x B 7	2940 x 68 x 18 mm ID 35342
2 x B 8	2386 x 78 x 18 mm ID 85228
7 x B 9	2386 x 95 x 18 mm ID 35322
22 x B 10	1920 x 3,2 x 19 mm ID 20799
6 x B 11	2042 x 190 x 26 mm ID 70218
6 x B 12	3372 x 190 x 26 mm ID 70219
13 x B 13	2333 x 42 x 28 mm ID 92762
1 x B 14	1900 x 68 x 68 mm ID 92922

	
KDI	
3 x K 1	1304 x 60 x 40 mm ID 35317
3 x K 2	2009 x 60 x 40 mm ID 35305
3 x K 3	2063 x 60 x 40 mm ID 35306
4 x K 4	1945 x 60 x 80 mm ID 35303
4 x K 5	2848 x 60 x 80 mm ID 35304

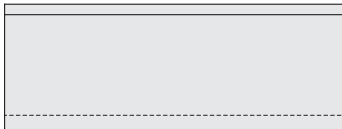
	
4 x E 1	2020 x 190 x 26 mm ID 70224

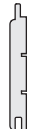
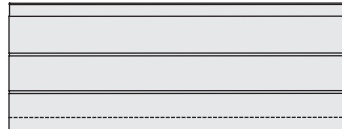

	
65 x R 1	2105 x 96 x 16 mm ID 35350
64 x R 2	2160 x 96 x 16 mm ID 79163

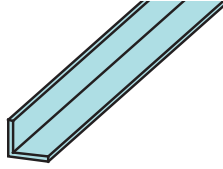

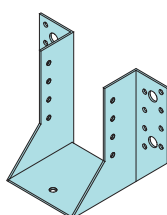
	
62 x G 1	2004 x 97 x 12,5mm ID 70220

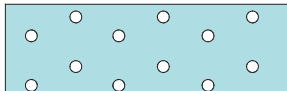
	
9 x M 1	1228 x 30 x 30 mm ID 79609

	
8 x	ID 33143

	
2 x X	120 x 40 x 2 mm ID 14148

		
400 x	4 x 50 mm	ID 3688
270 x	4 x 70 mm	ID 3689
70 x	6 x 120 mm	ID 9205

		
210 x	4 x 50 mm	ID 93698

	
1200 x	2,2 x 50 mm ID 5621

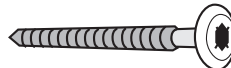
	
50 x	8 x 100mm ID 93697

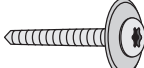
	
35 x	4 x 40mm ID 36178

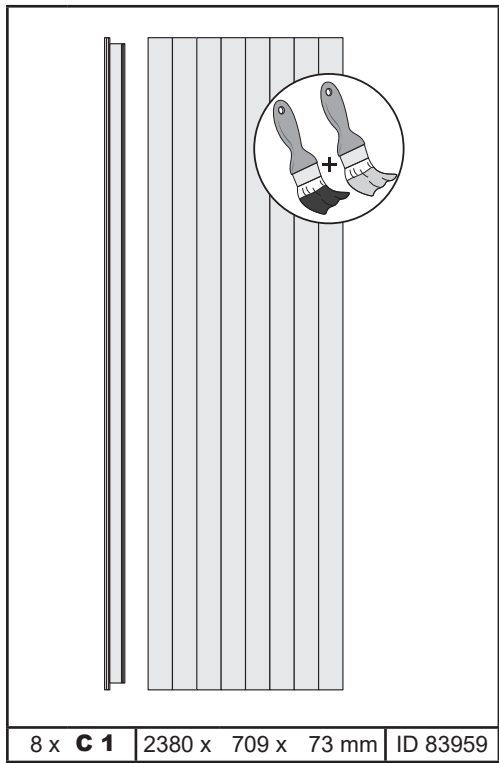

8 x **C 1** | 2380 x 709 x 73 mm | ID 83959

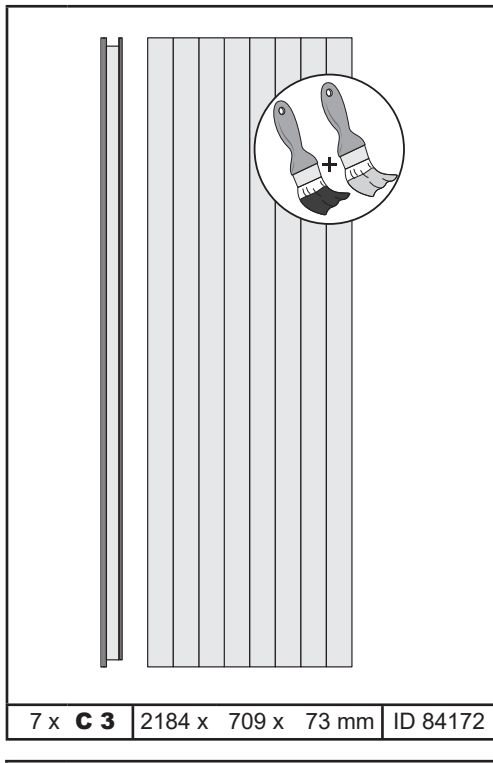

7 x **C 3** | 2184 x 709 x 73 mm | ID 84172

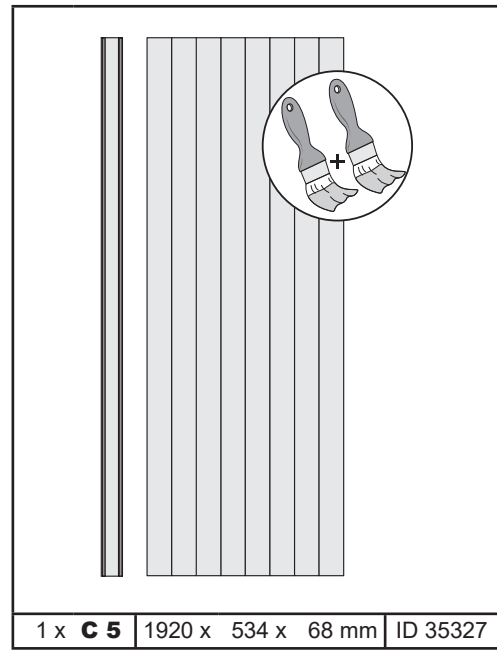

1 x **C 5** | 1920 x 534 x 68 mm | ID 35327

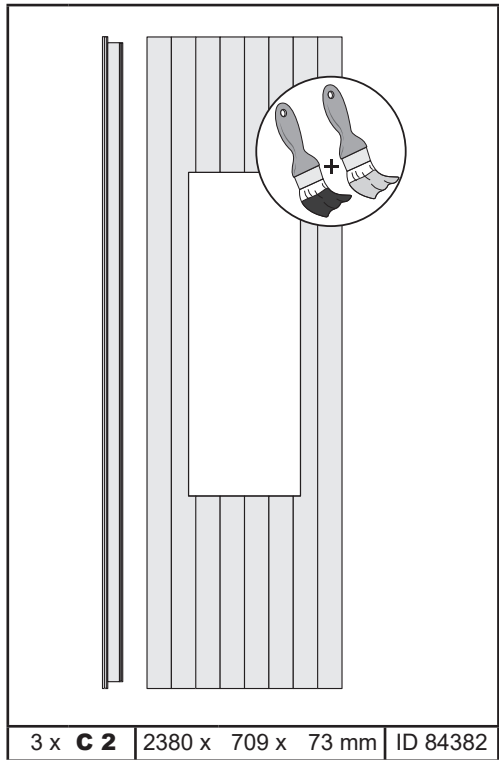

3 x **C 2** | 2380 x 709 x 73 mm | ID 84382

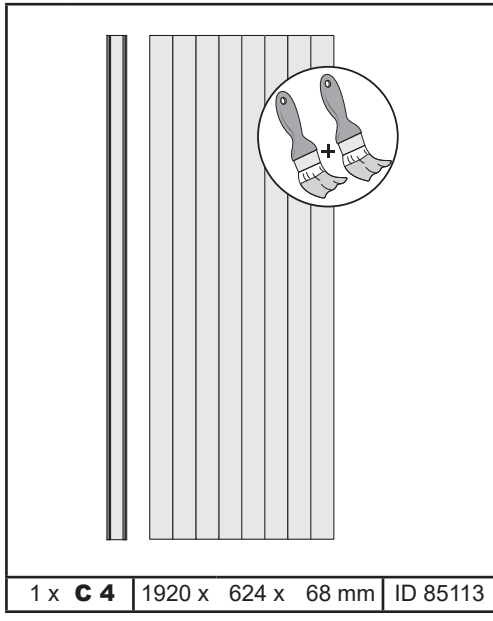

1 x **C 4** | 1920 x 624 x 68 mm | ID 85113

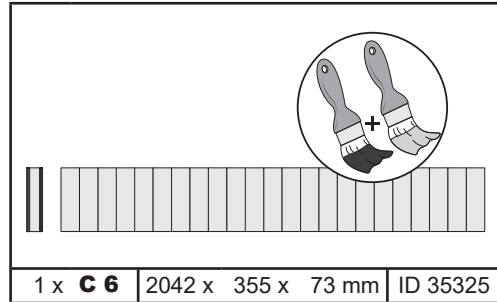

1 x **C 6** | 2042 x 355 x 73 mm | ID 35325

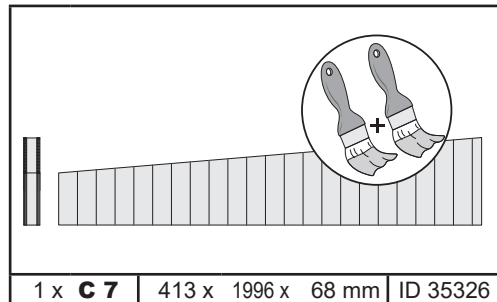

1 x **C 7** | 413 x 1996 x 68 mm | ID 35326

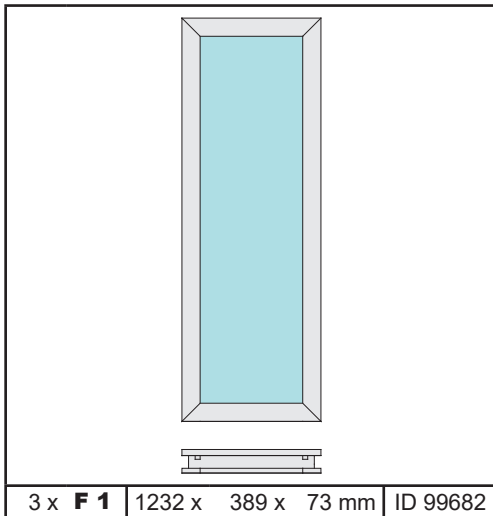

3 x **F 1** | 1232 x 389 x 73 mm | ID 99682

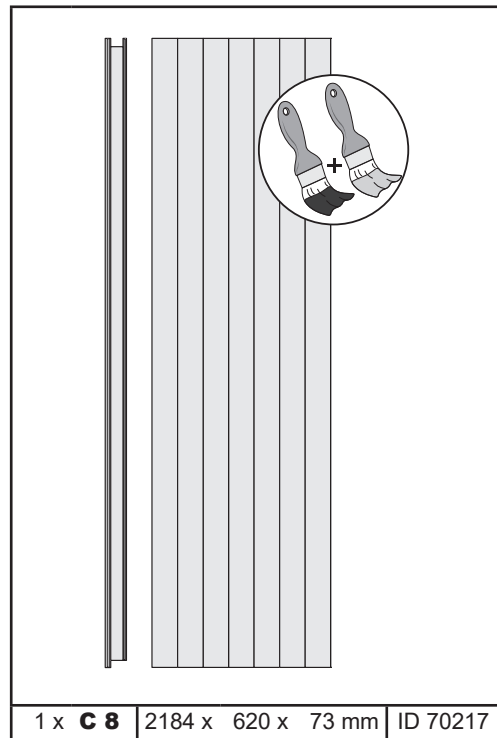

1 x **C 8** | 2184 x 620 x 73 mm | ID 70217

51565

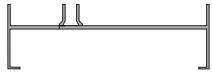

2 x **Z1** | 2000 x 32 x 63 mm

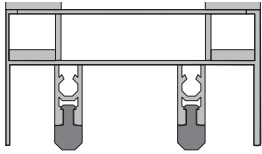

1 x **Z2** | 1962 x 35 x 60 mm

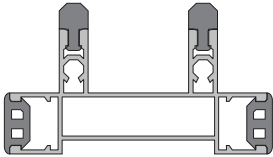

1 x **Z3** | 1962 x 35 x 60 mm



5 x | 4,2 x 50 mm

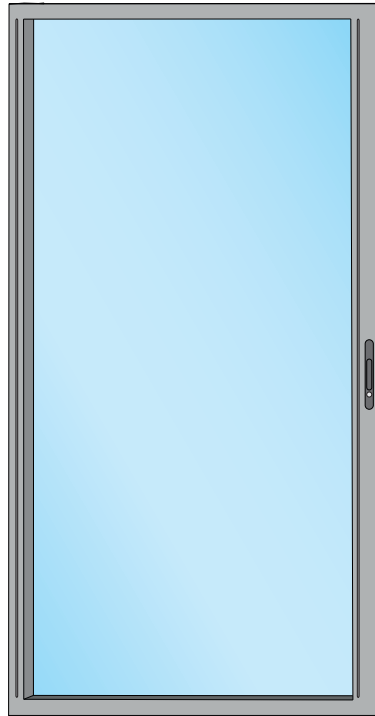

1 x **Z6** | 2000 x 1000 x 40 mm



1 x **Z5** | 2000 x 1000 x 40 mm



15 x | 4,2 x 50 mm

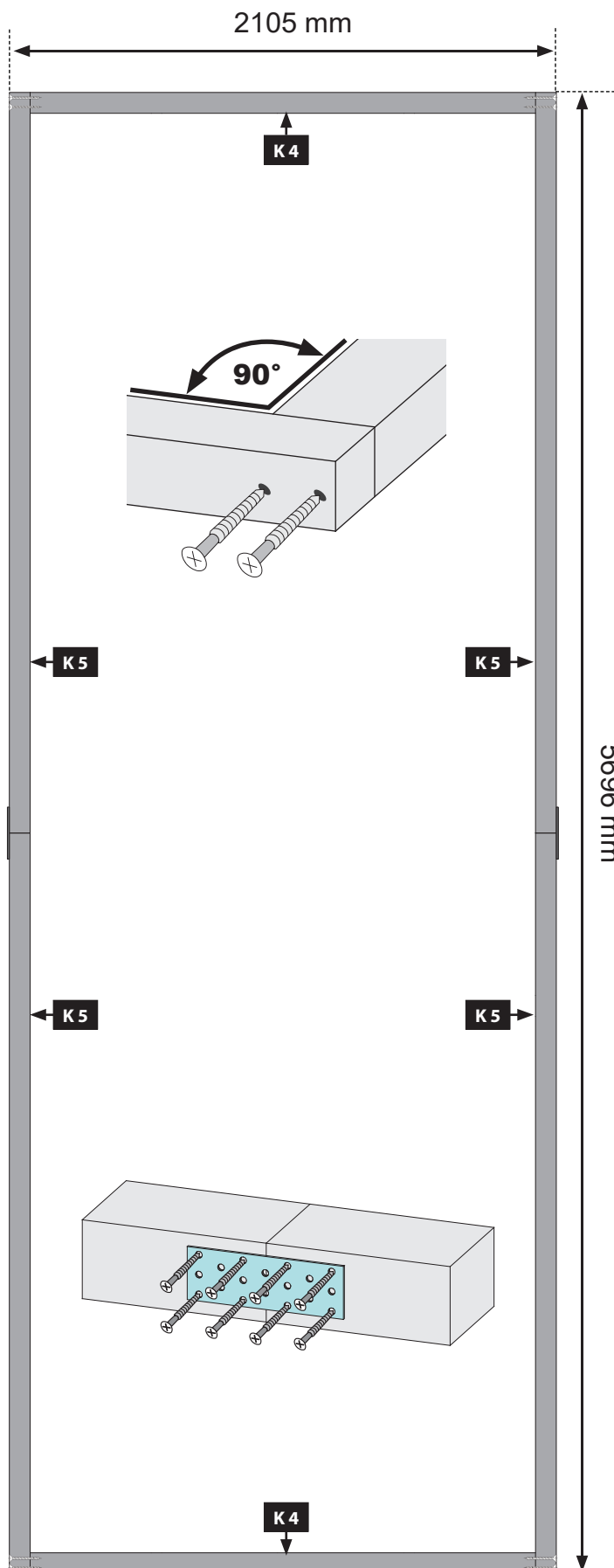
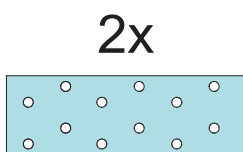
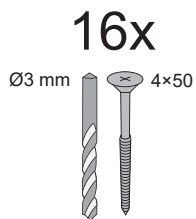
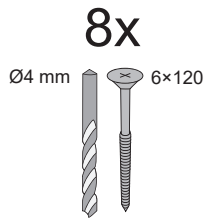
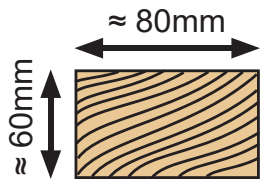

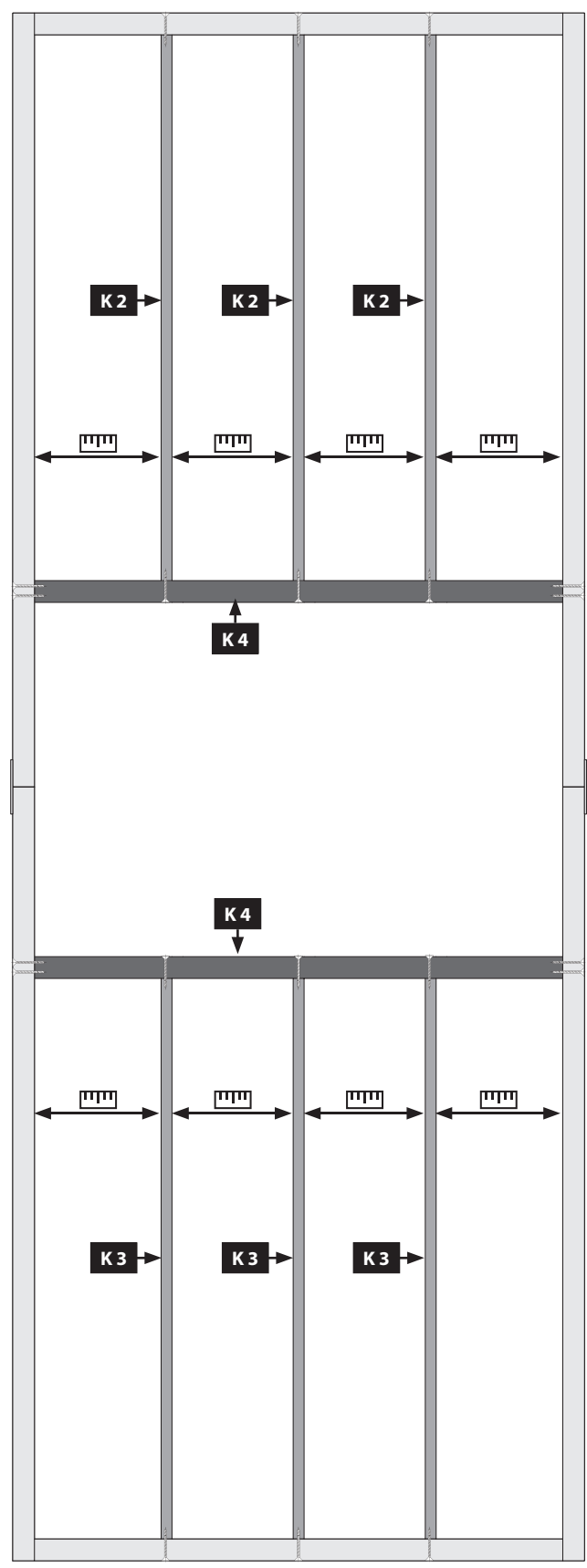
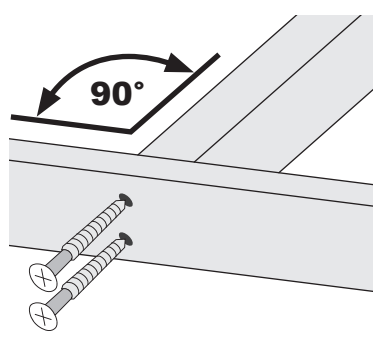
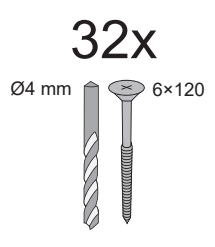

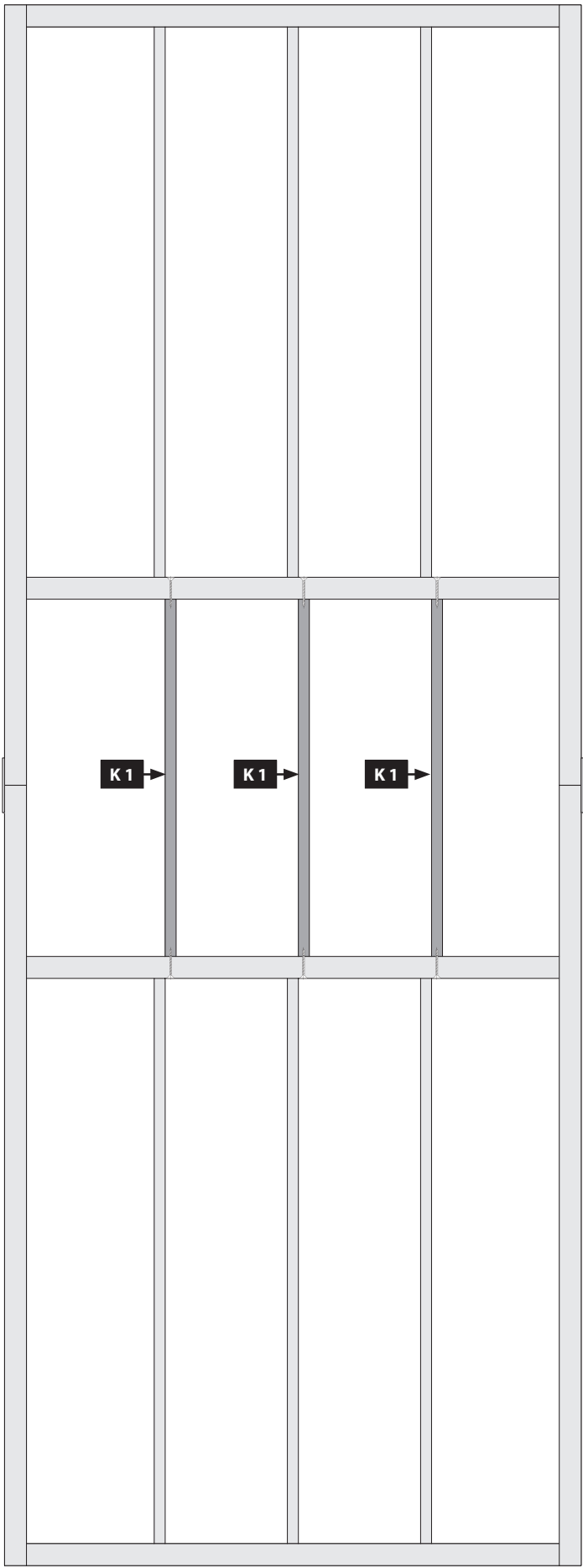
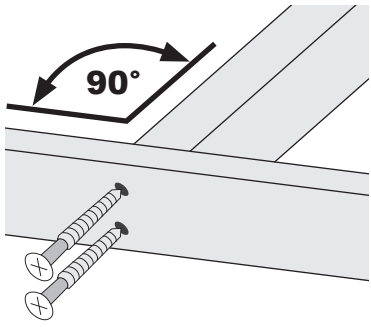
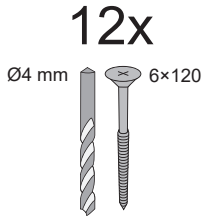
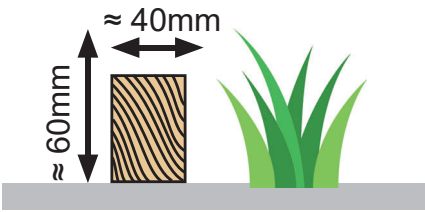





 Breite Seite nach oben

 Bred side opad

 Larghezza verso l'alto

 Width side up

 Breedte side up

 Šířka stranou nahoru

 Largeur vers le haut

 Ancho de banda de hasta

 Široka stran navzgor

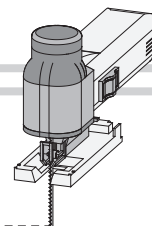

04

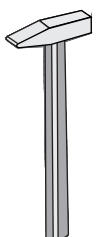

~650x

-  Bündig!
-  Flush!
-  Affleurement!
-  Gelijk!
-  I flugt!
-  Aras!
-  Combacia!
-  Stejný!
-  Splakovanie!

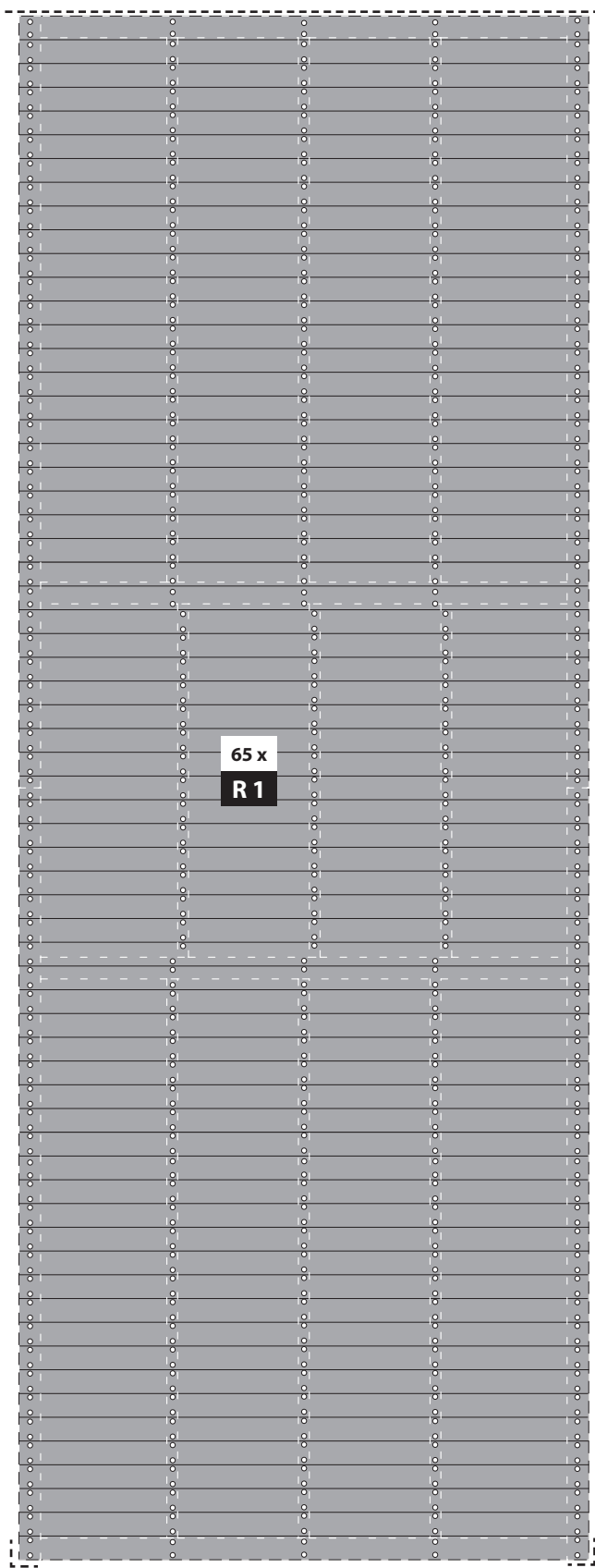
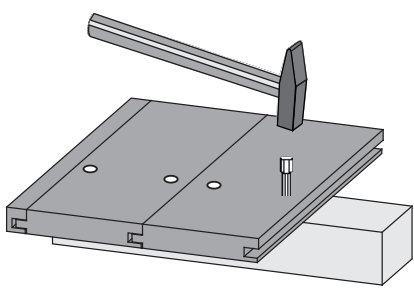

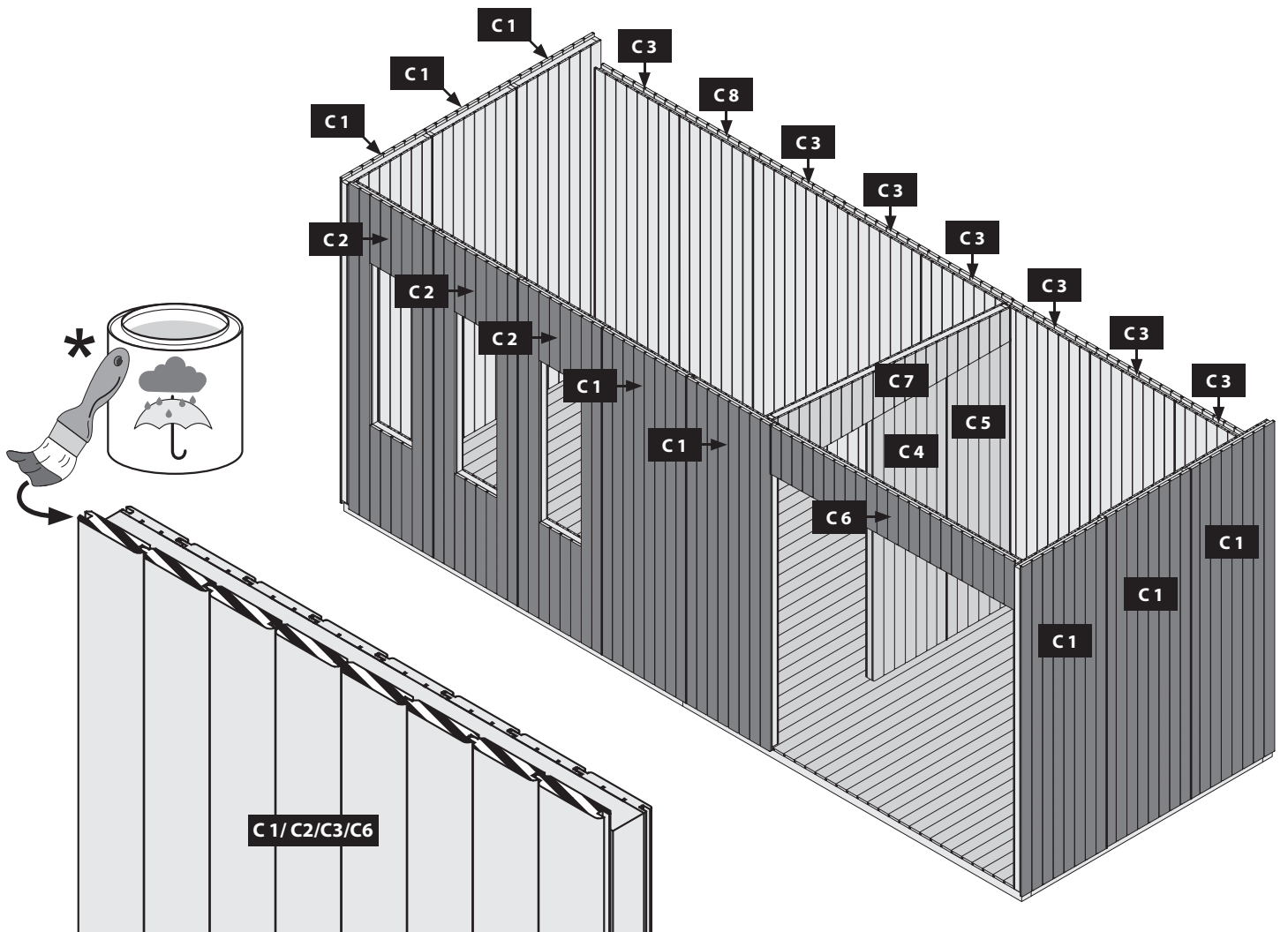

05

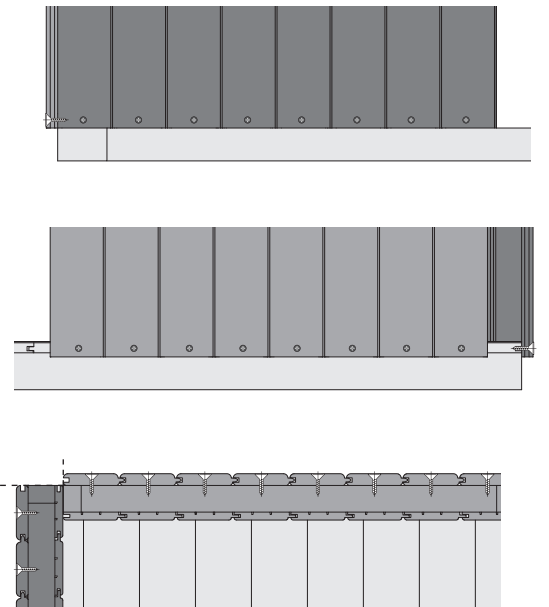
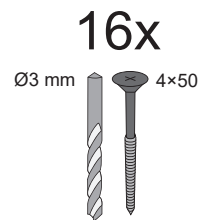
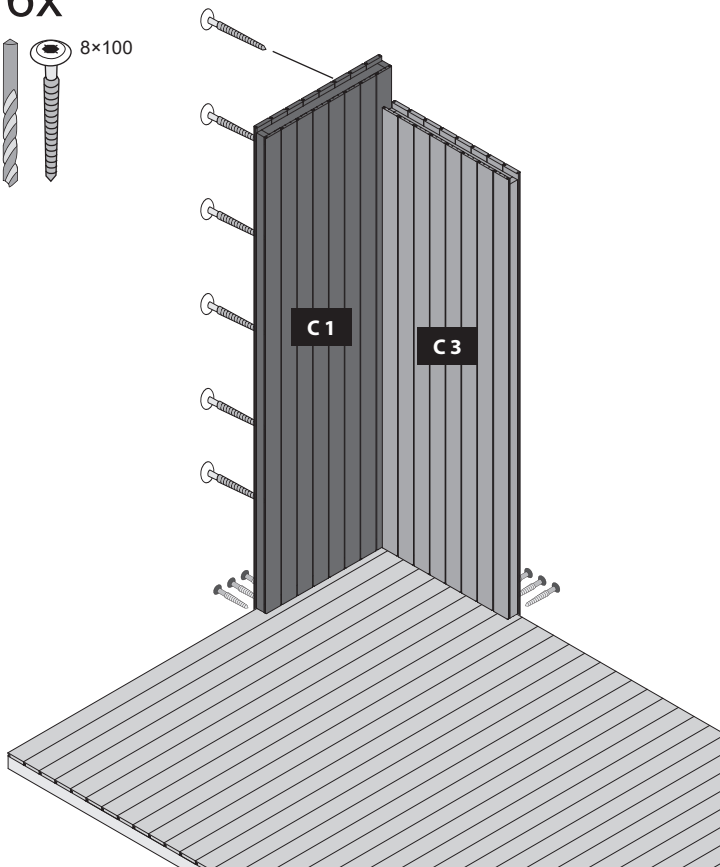
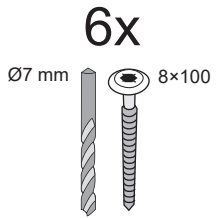

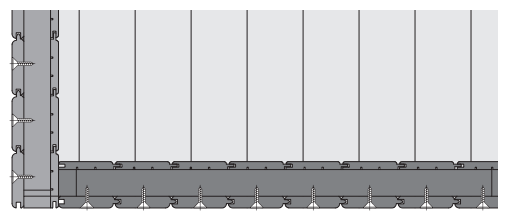
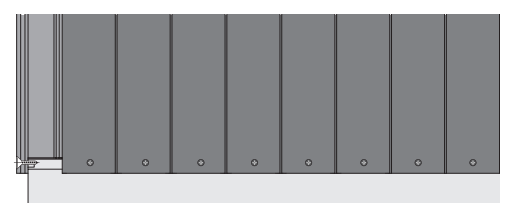
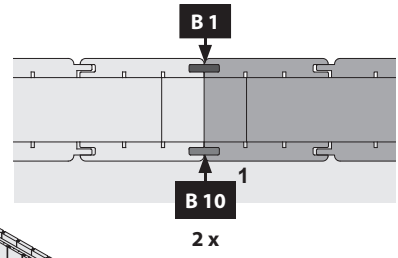
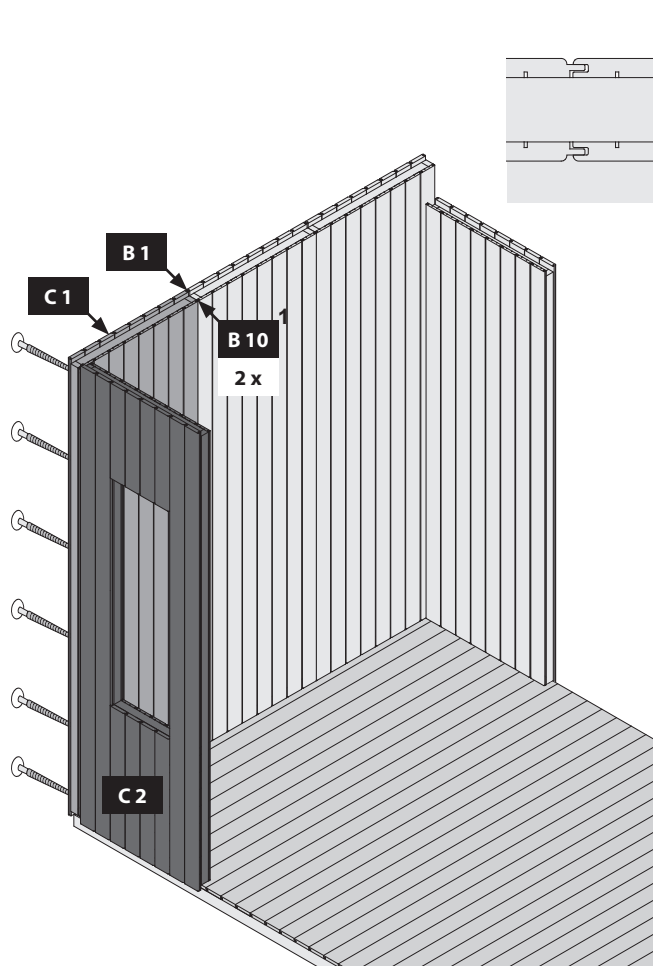
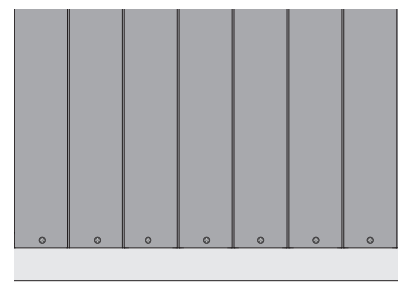
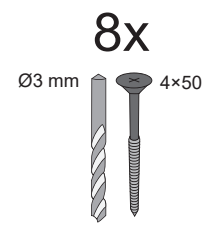
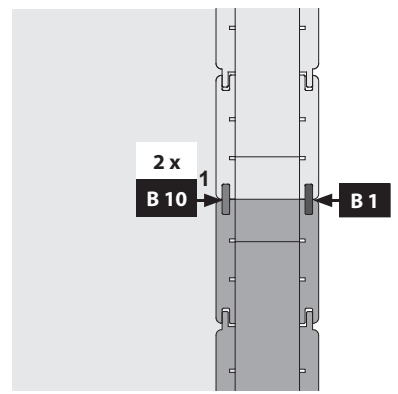
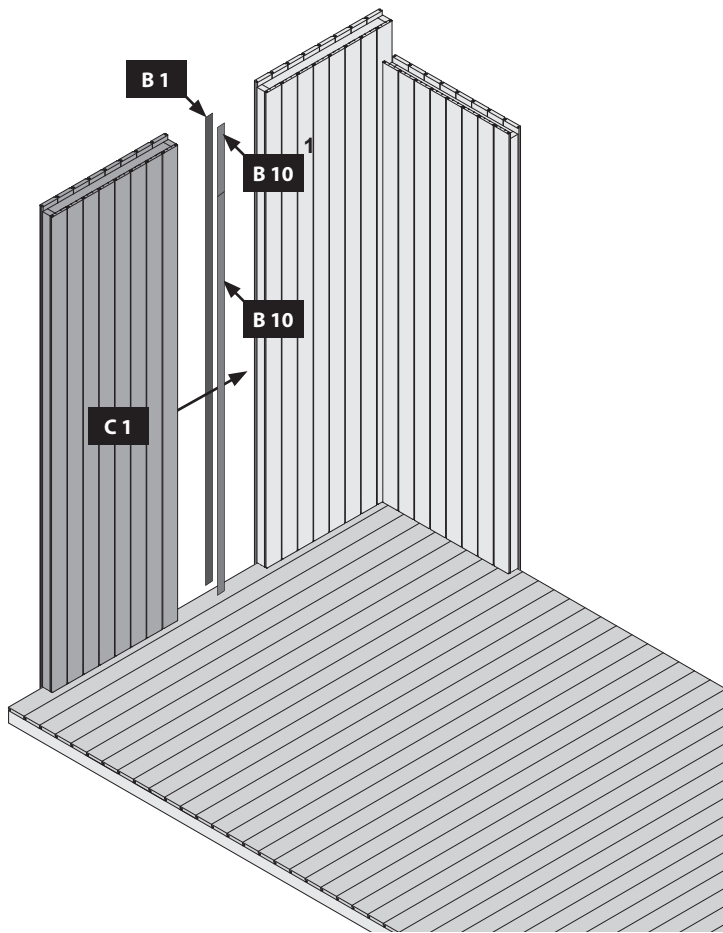

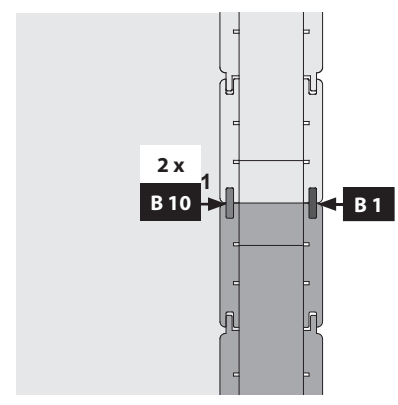
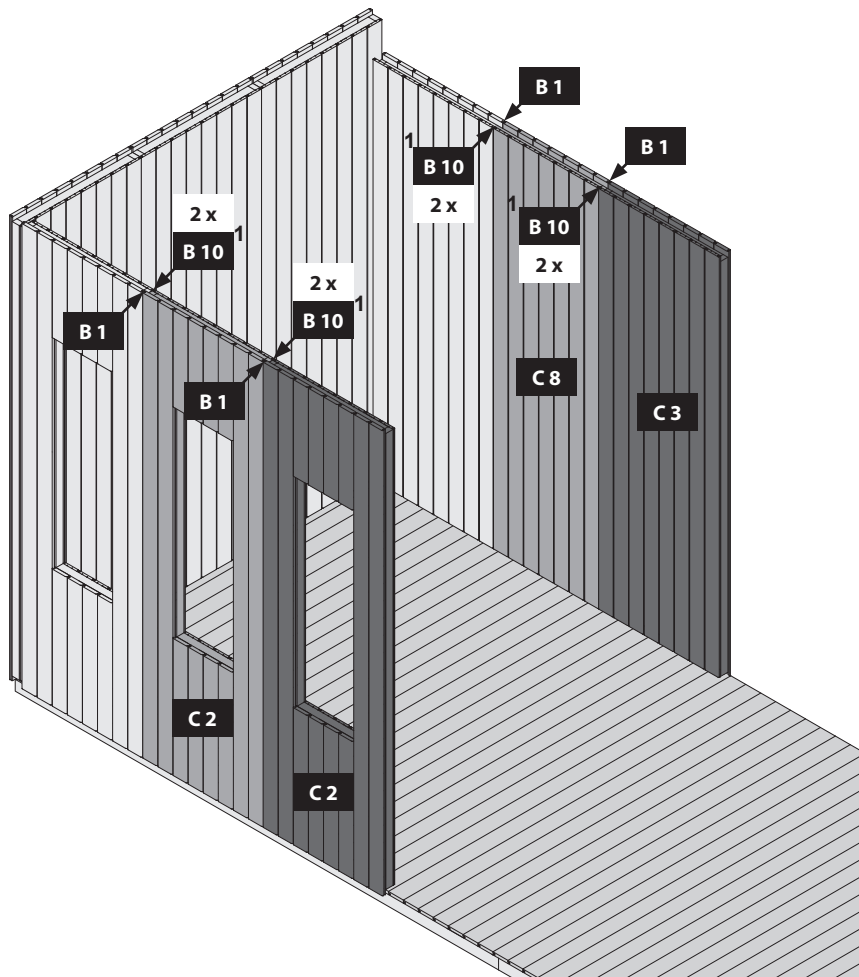

31x

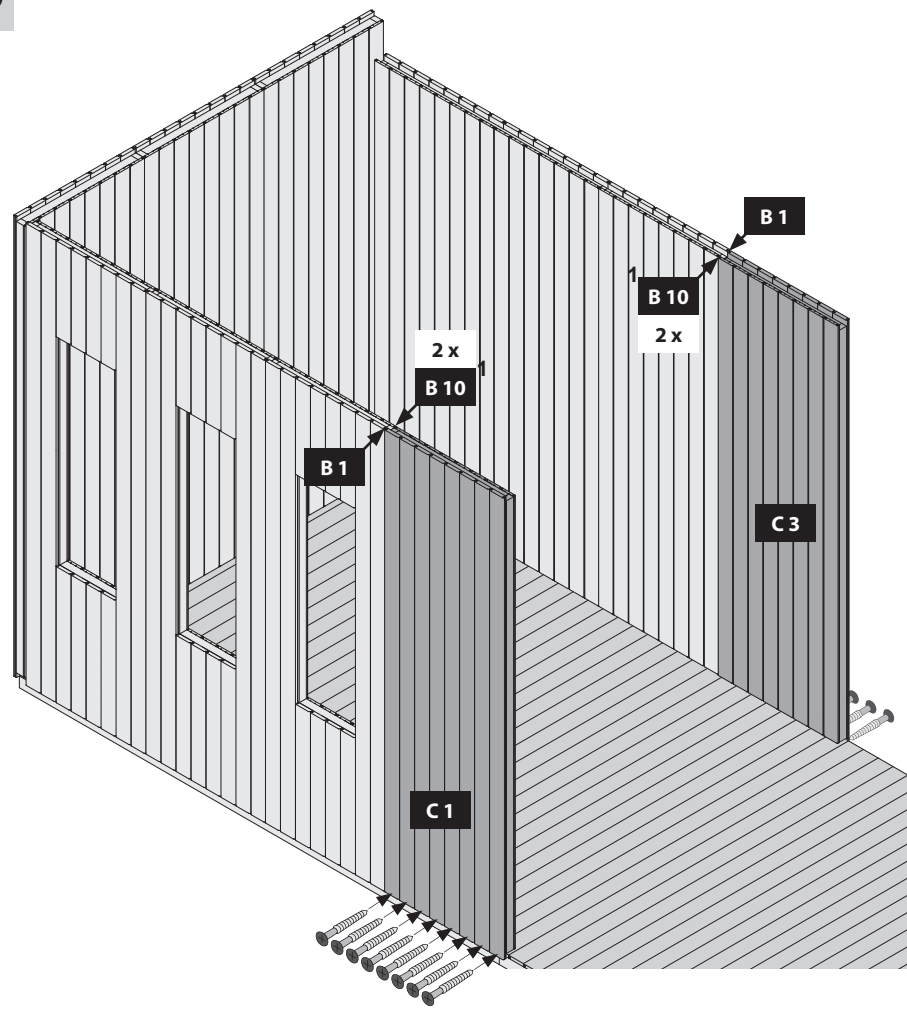
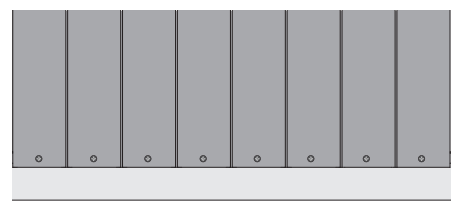
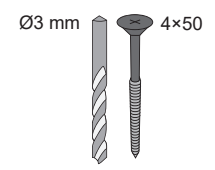

16x

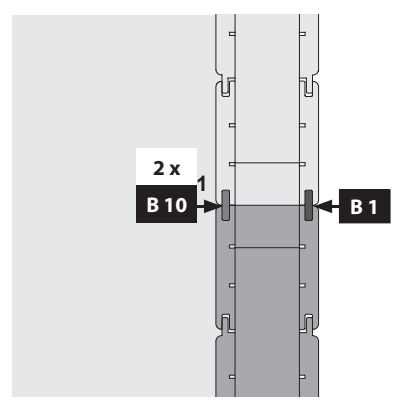
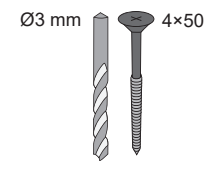

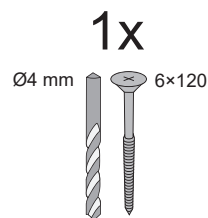
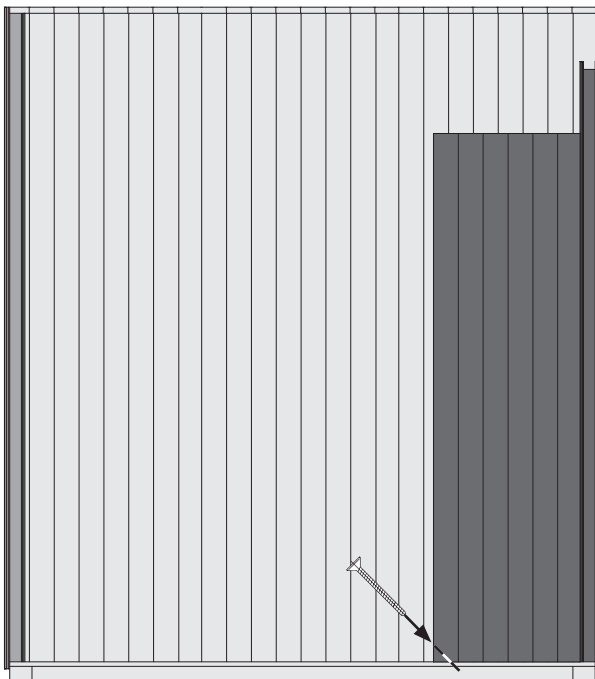
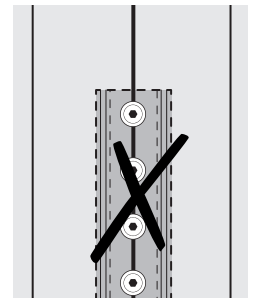
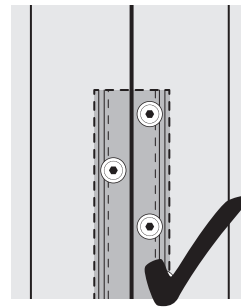
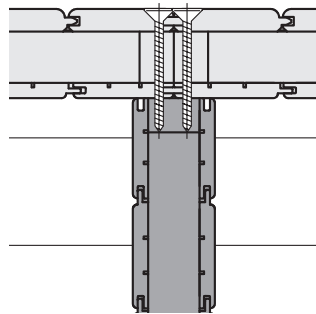
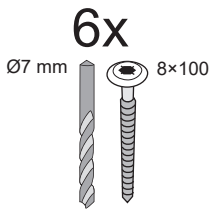
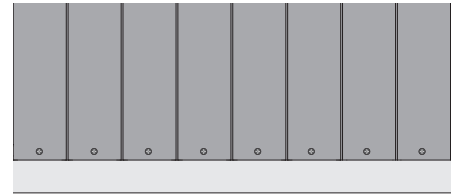
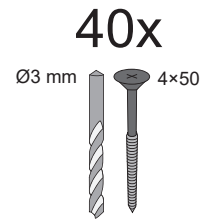
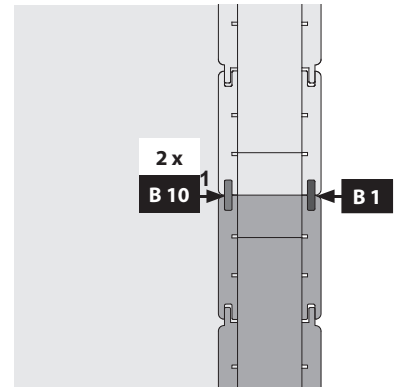
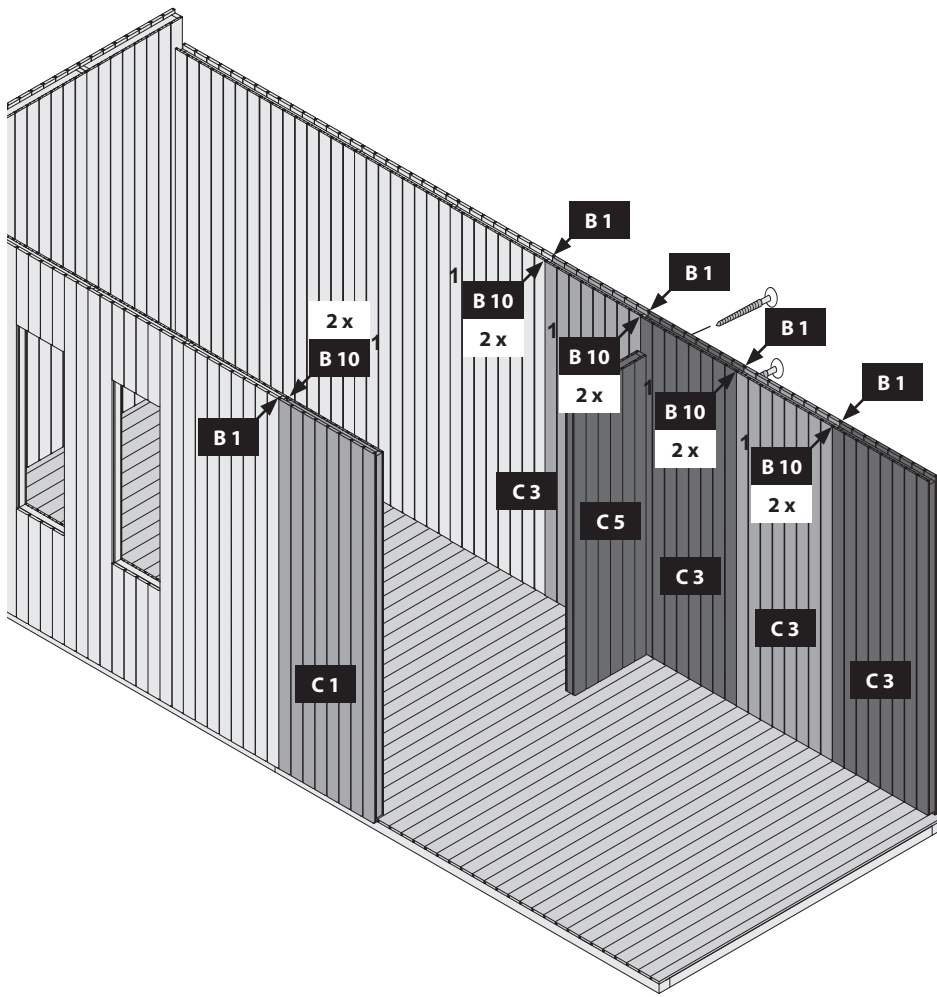

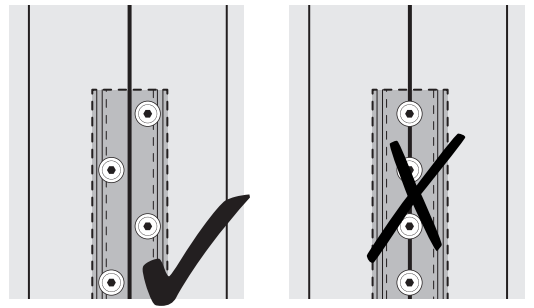
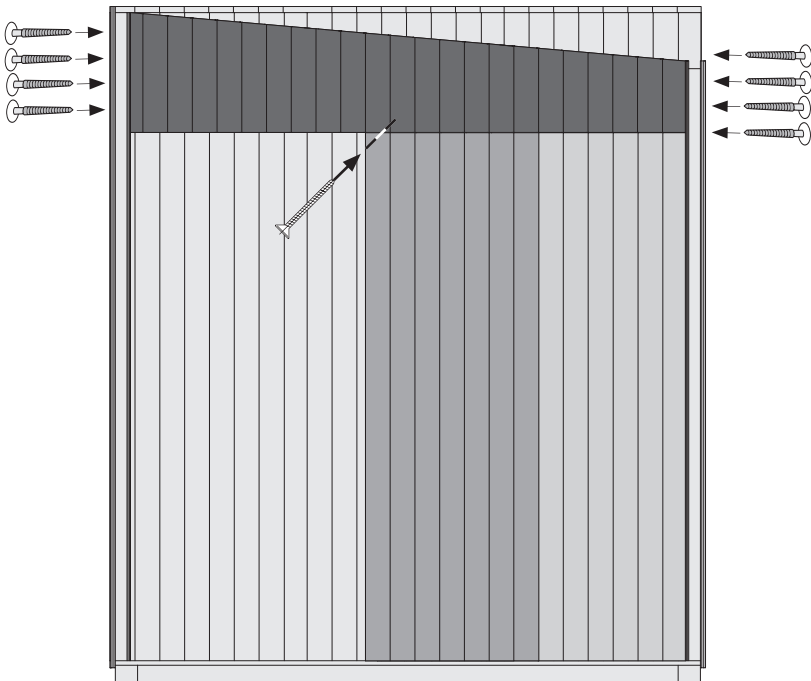
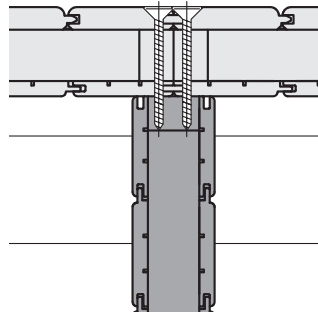
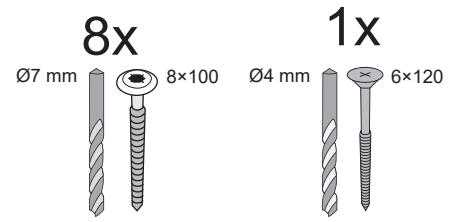
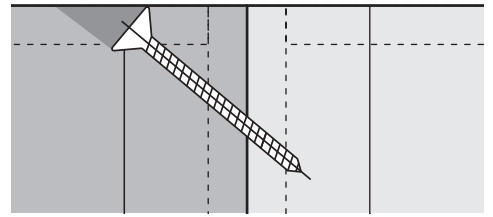
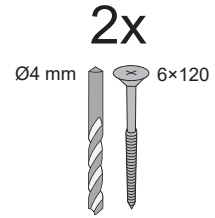
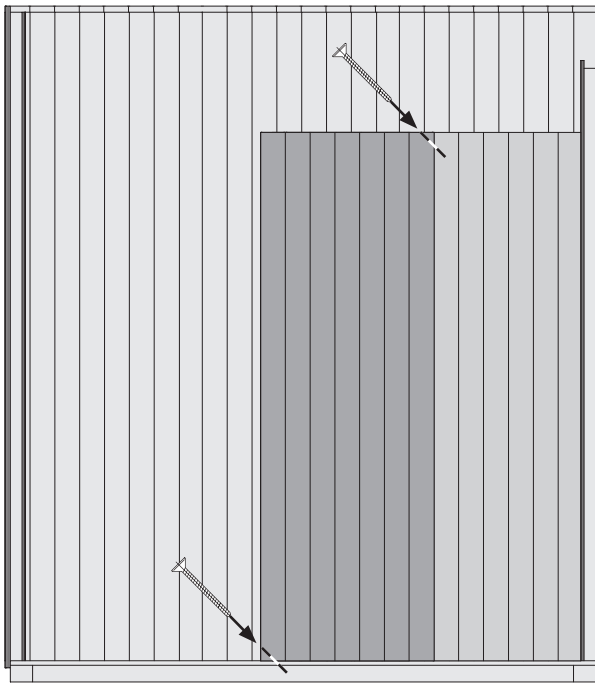
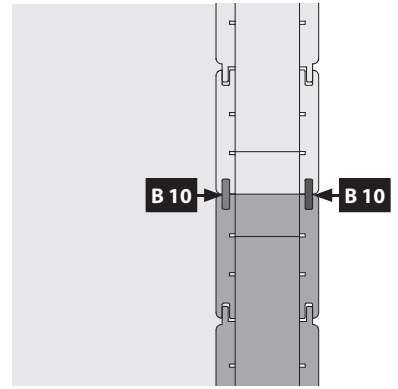
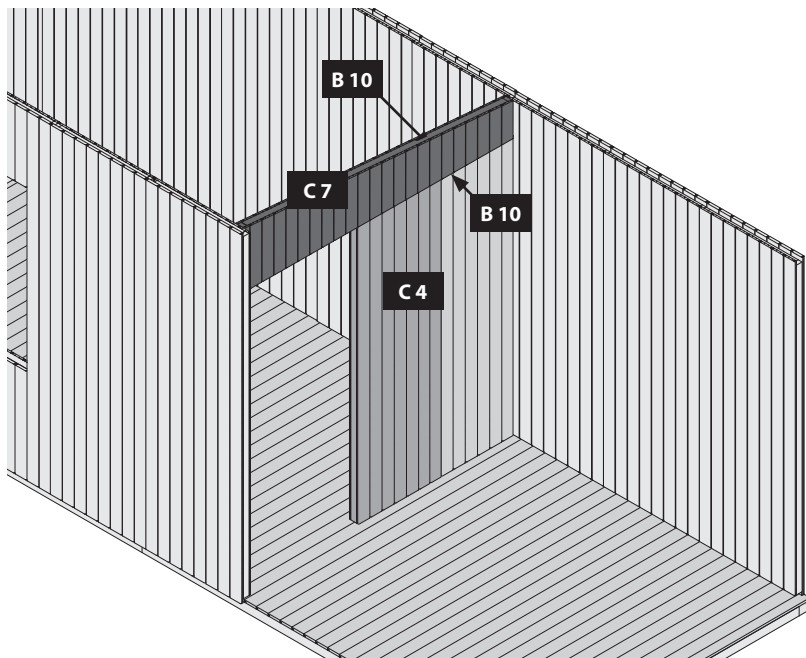

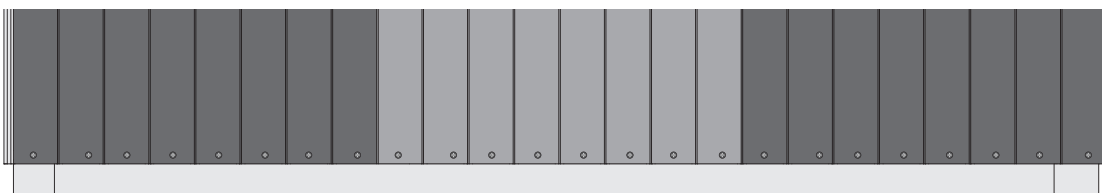
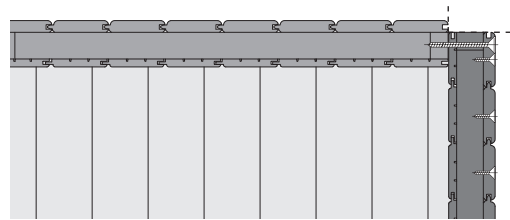
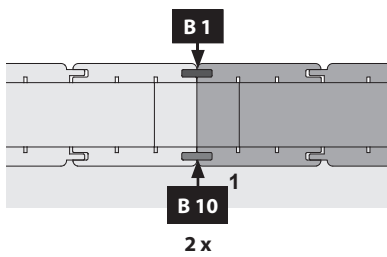
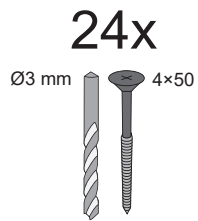
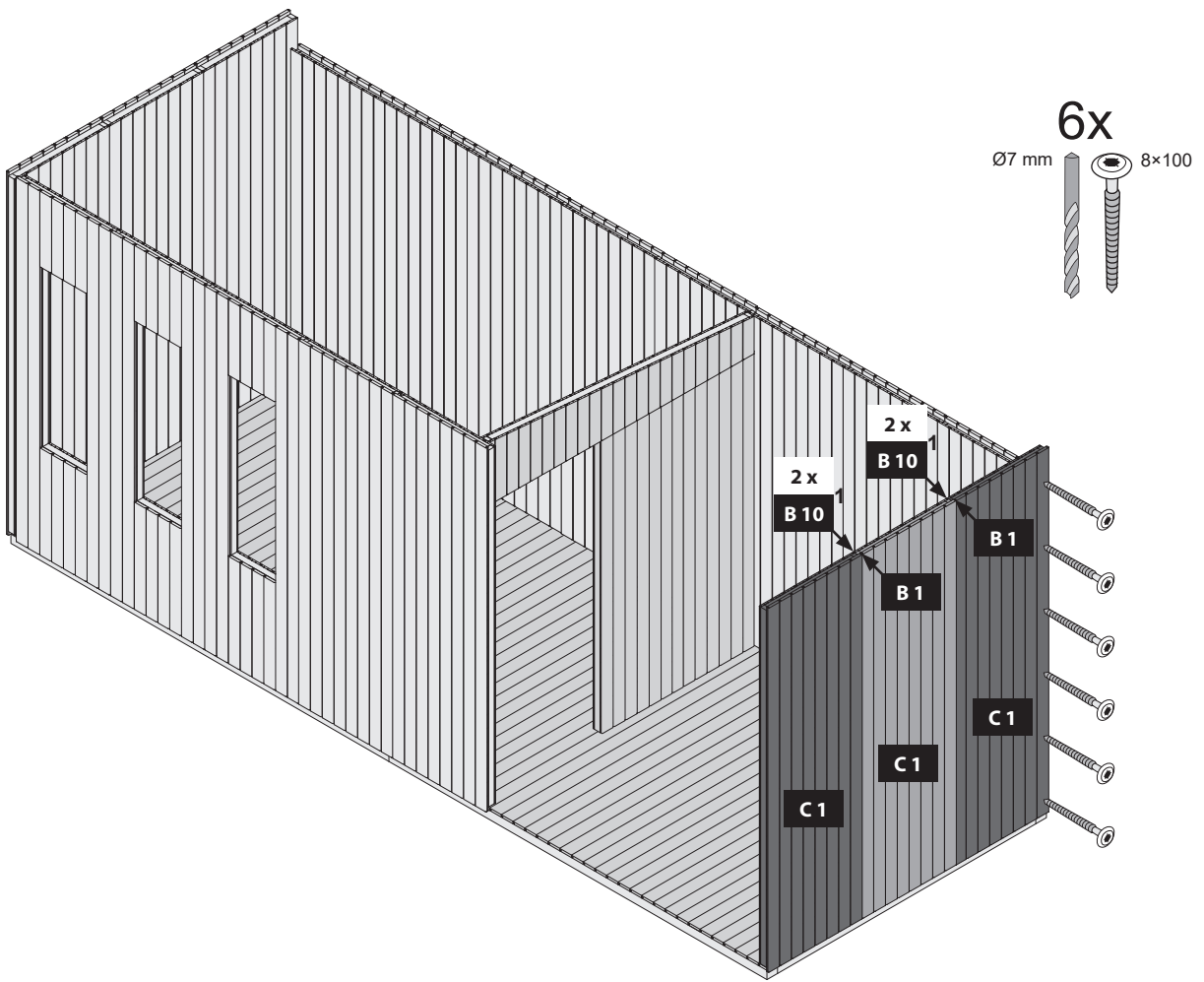

13

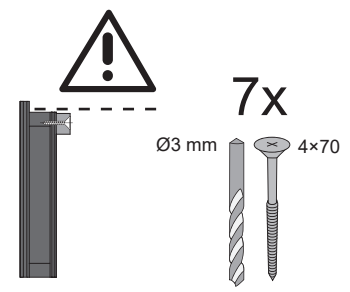
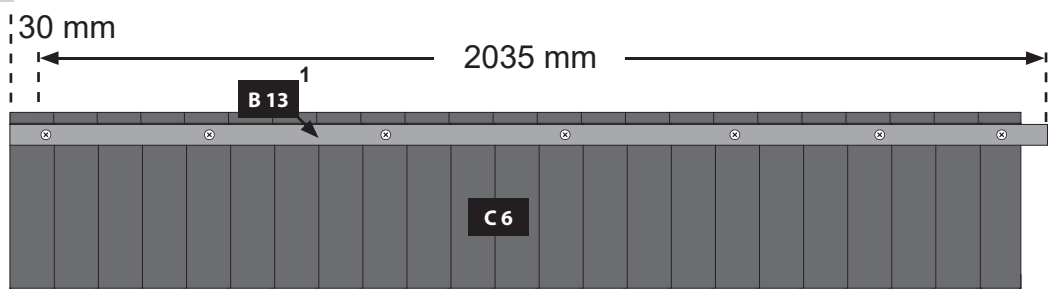

14

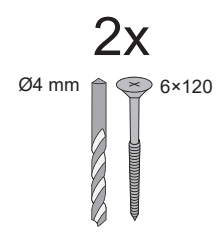
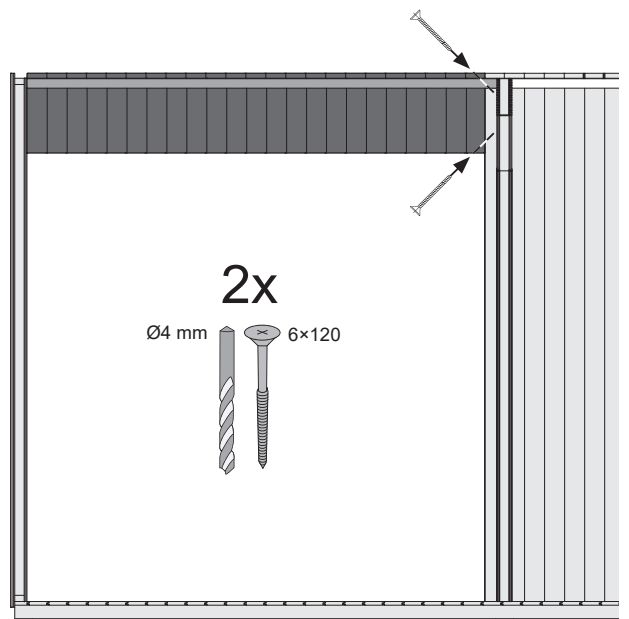
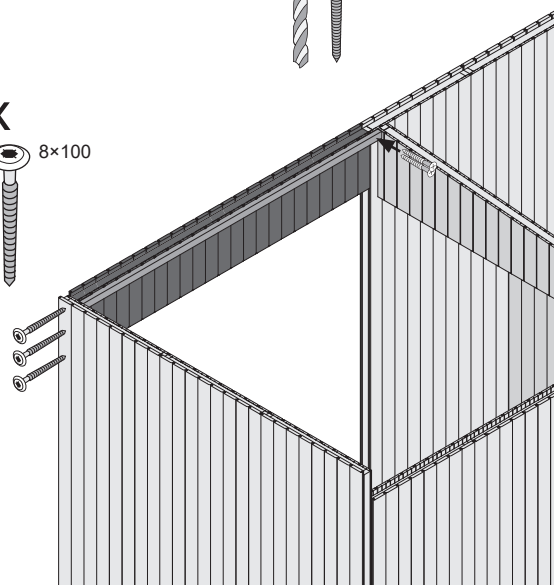
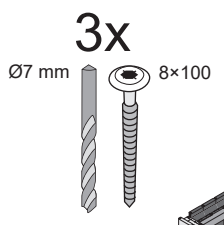
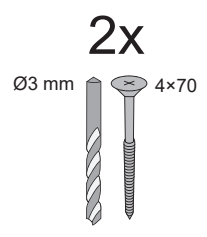
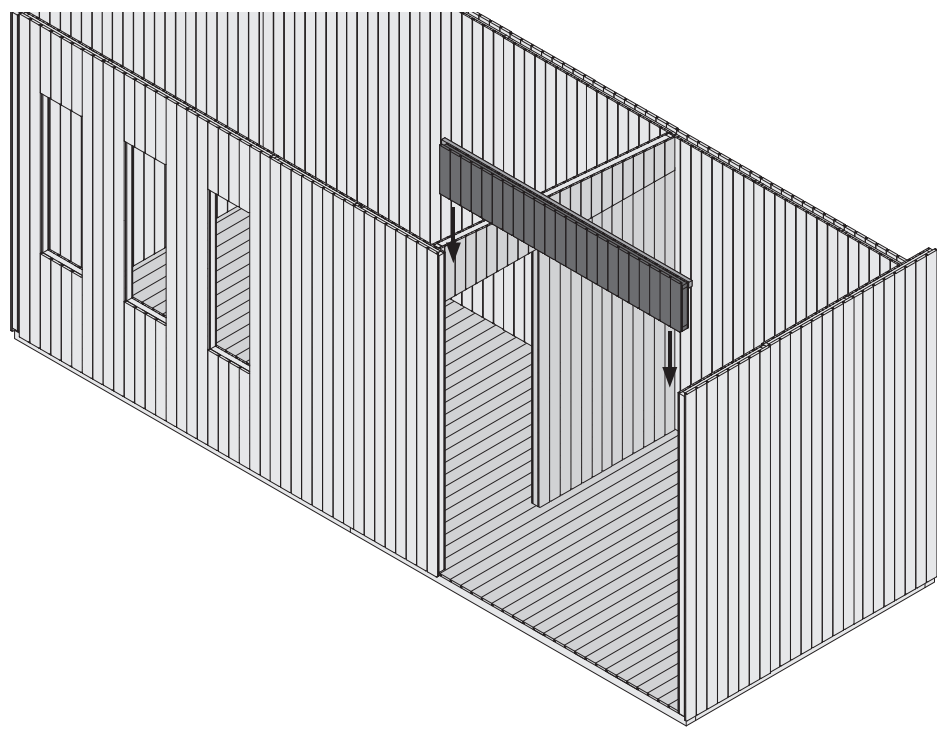

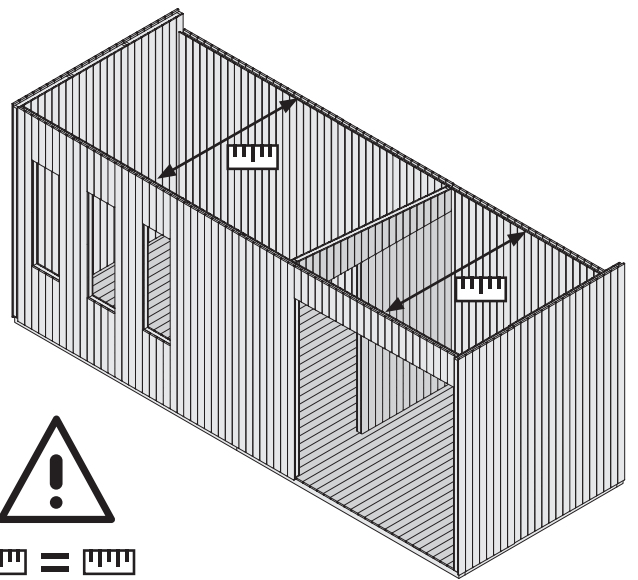
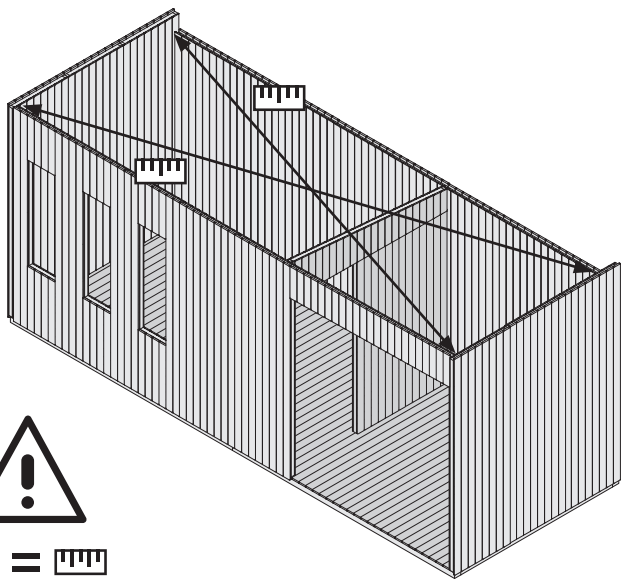

15

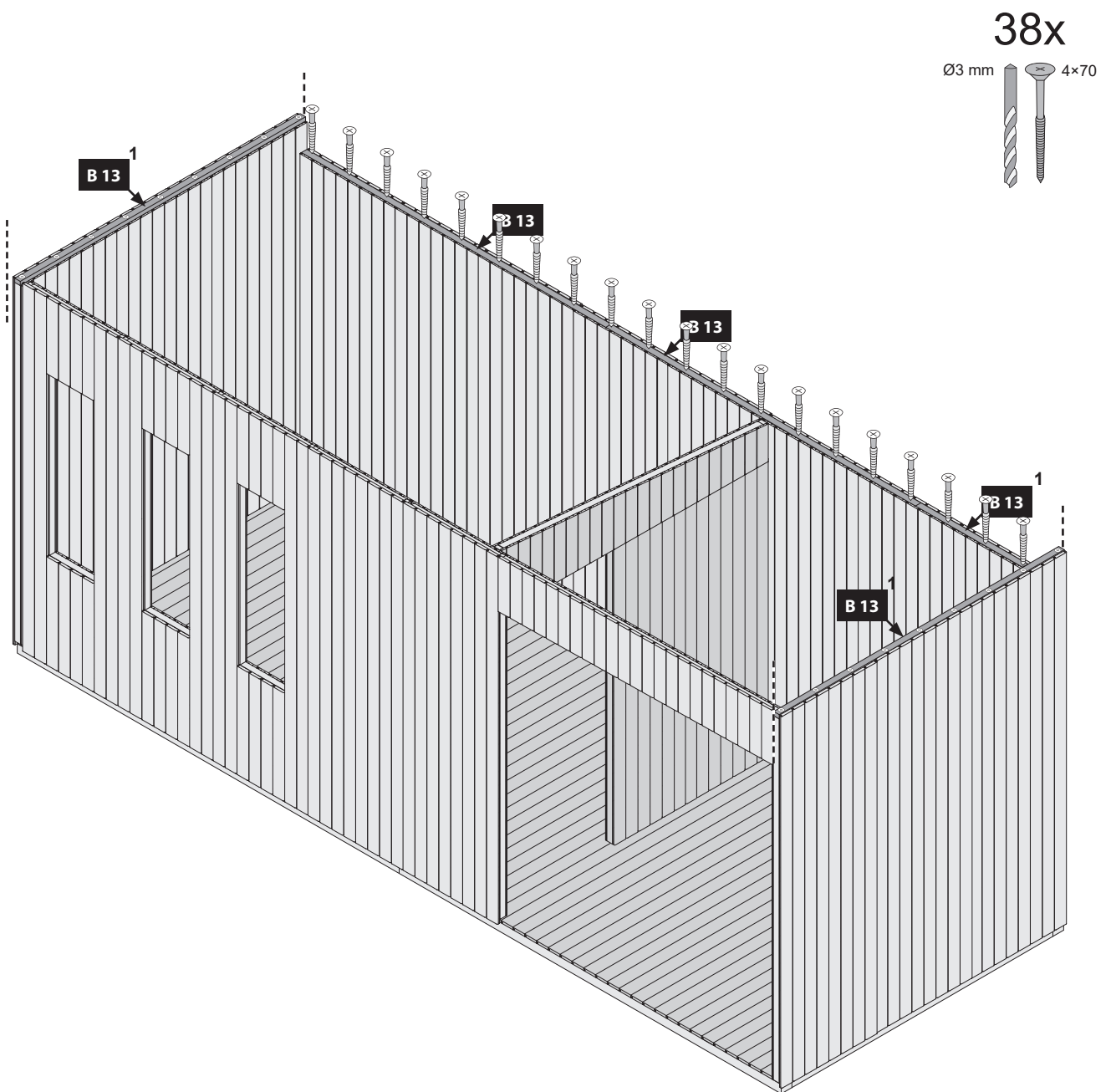

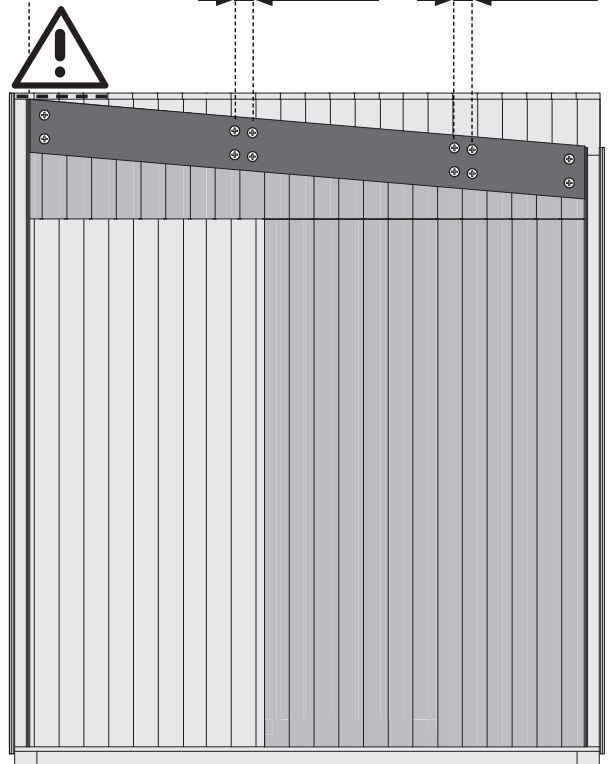
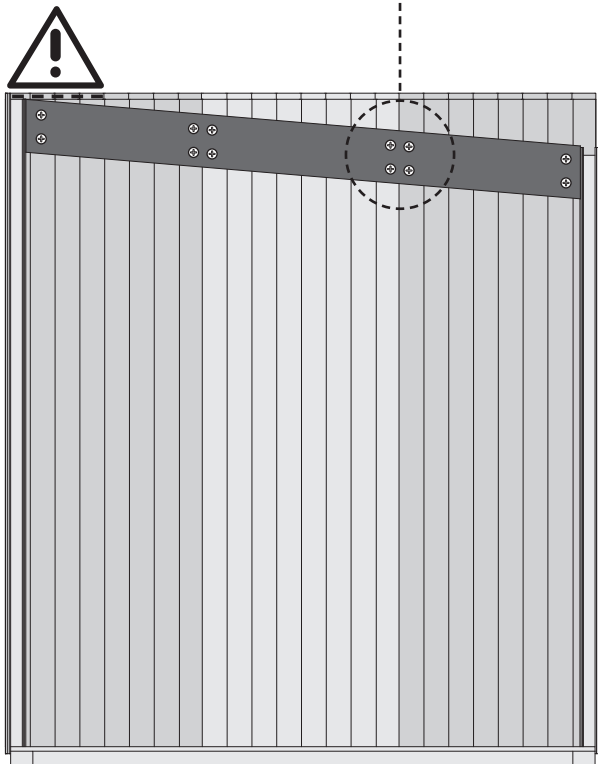
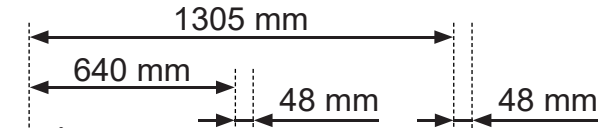
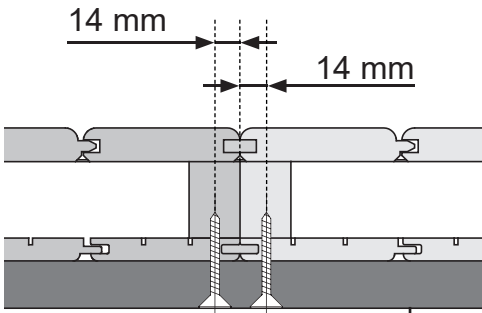
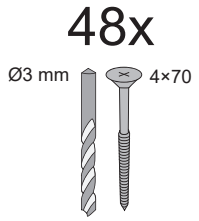
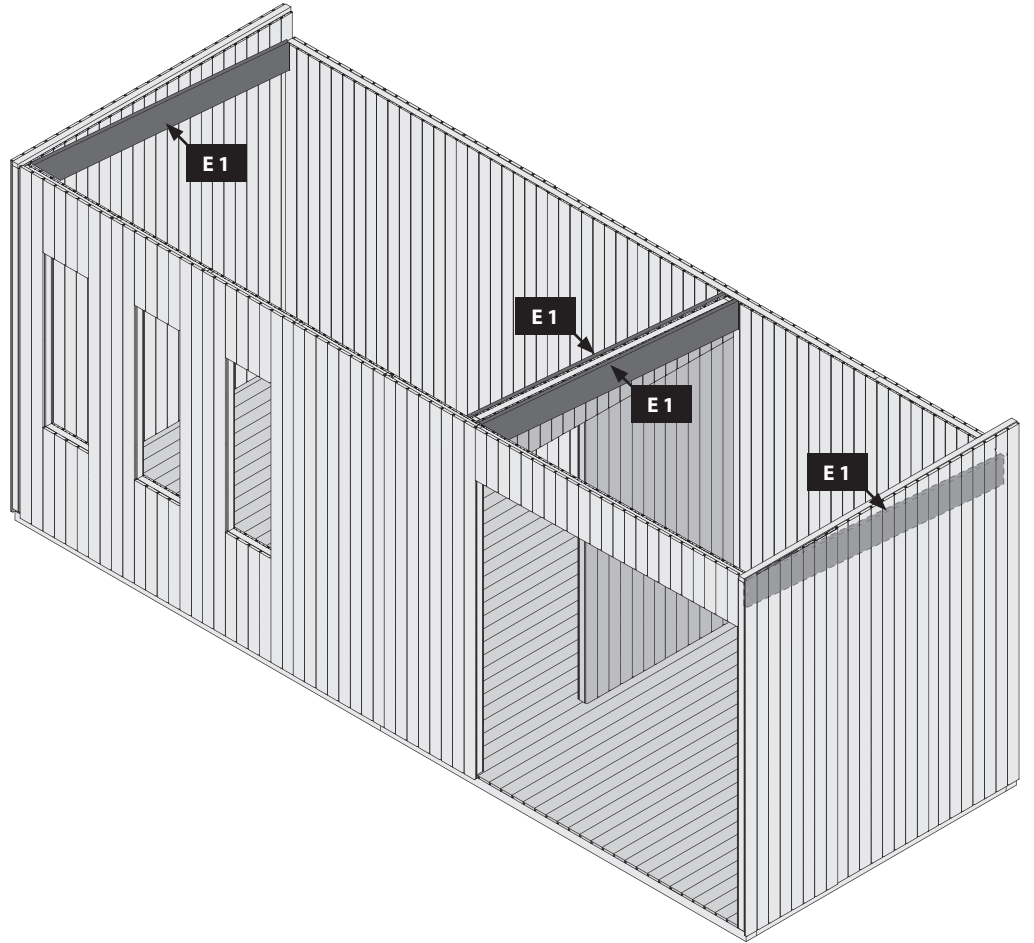

2x

40x

Ø3 mm 4x70

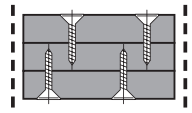
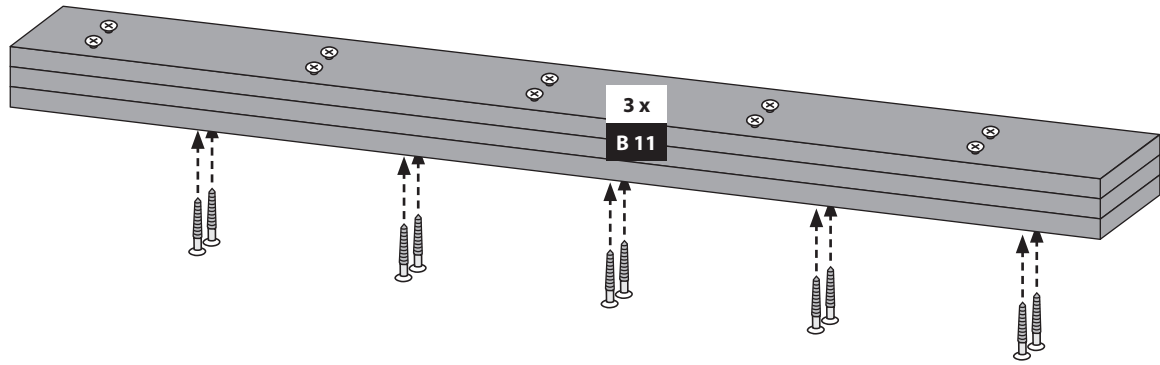
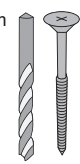

2x

68x

Ø3 mm 4x70

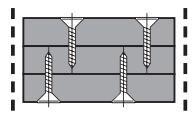
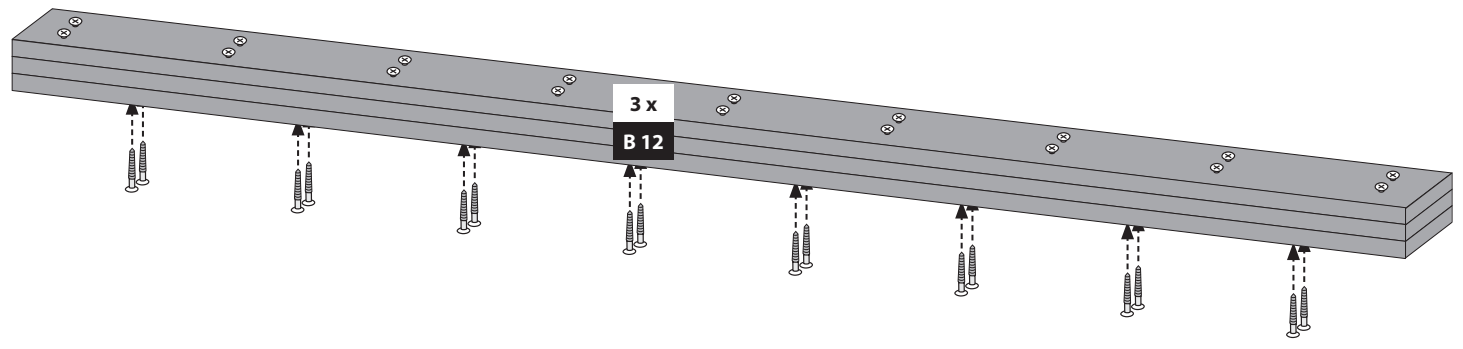
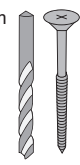

64x

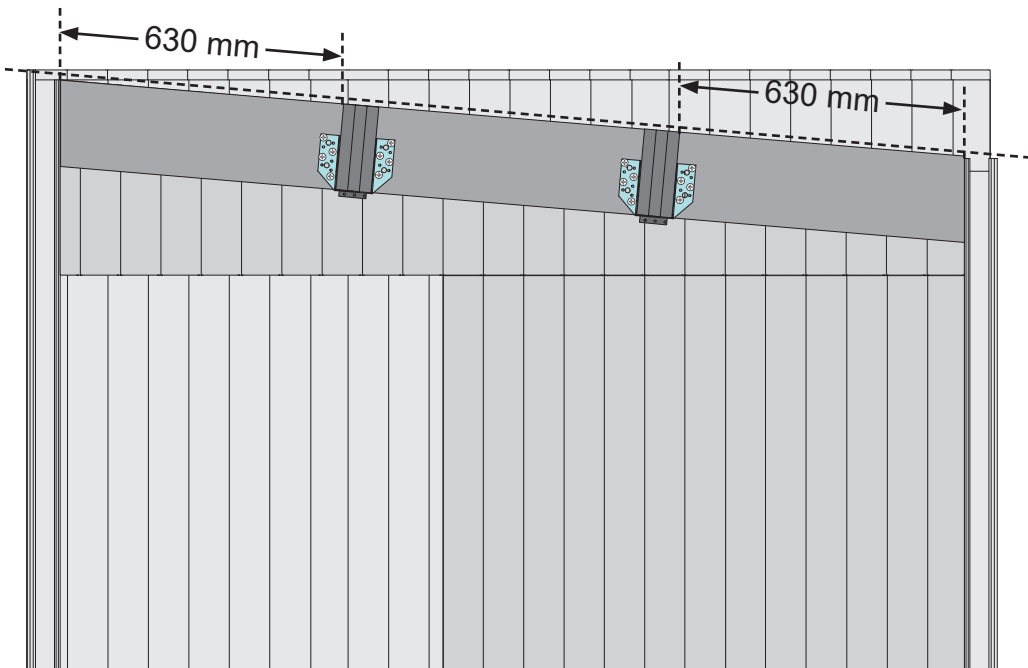
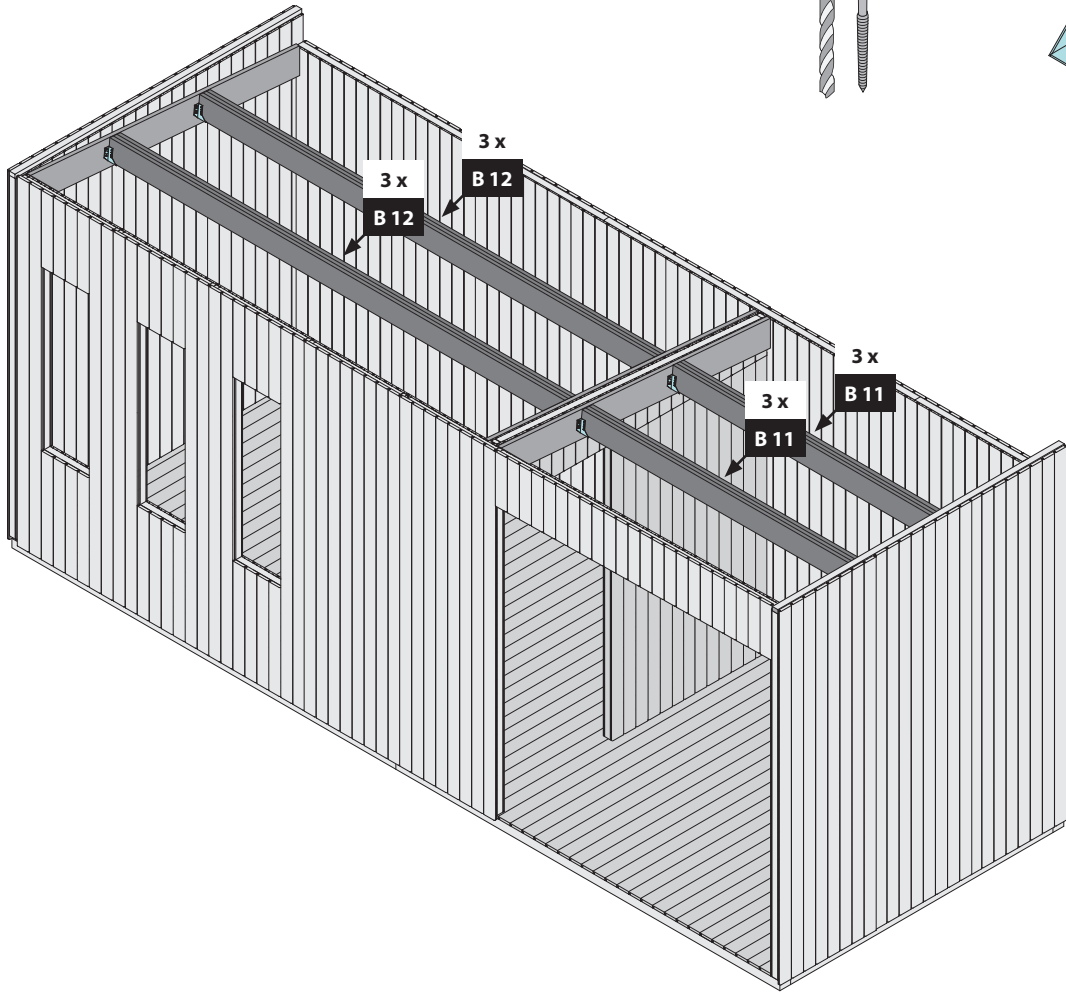
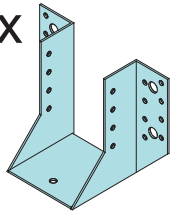
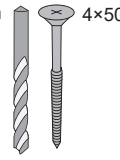

8x

Ø3 mm 4x50

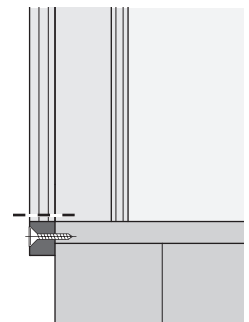
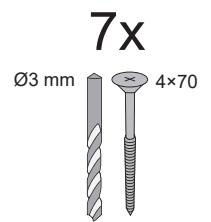
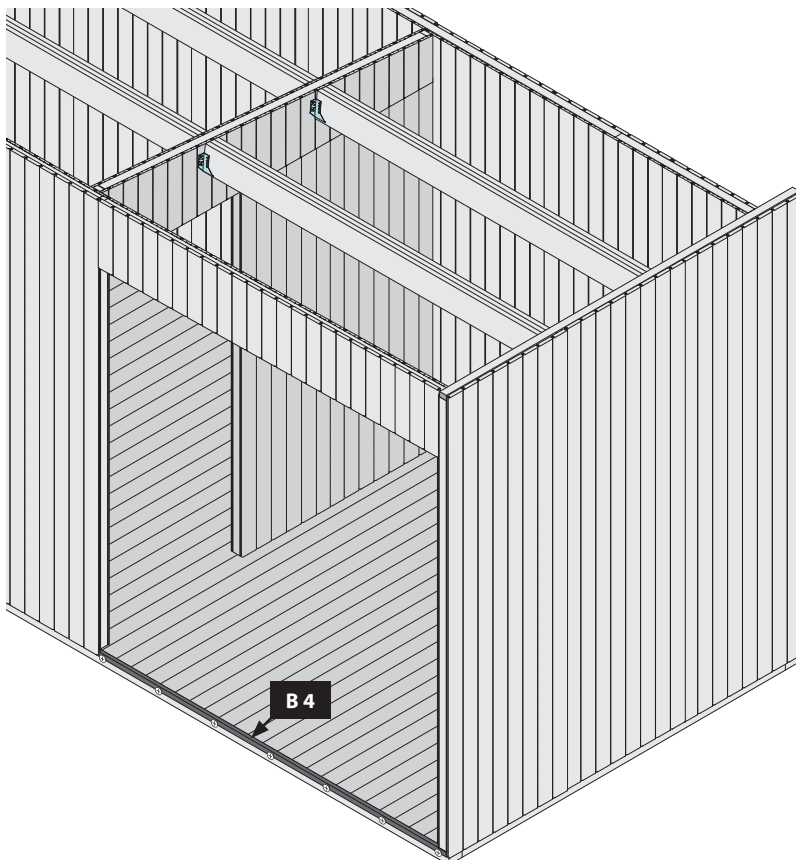
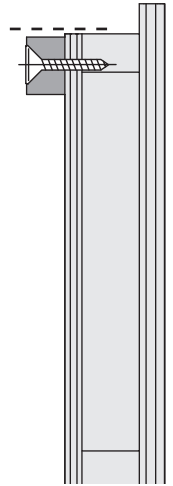
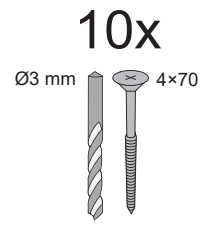
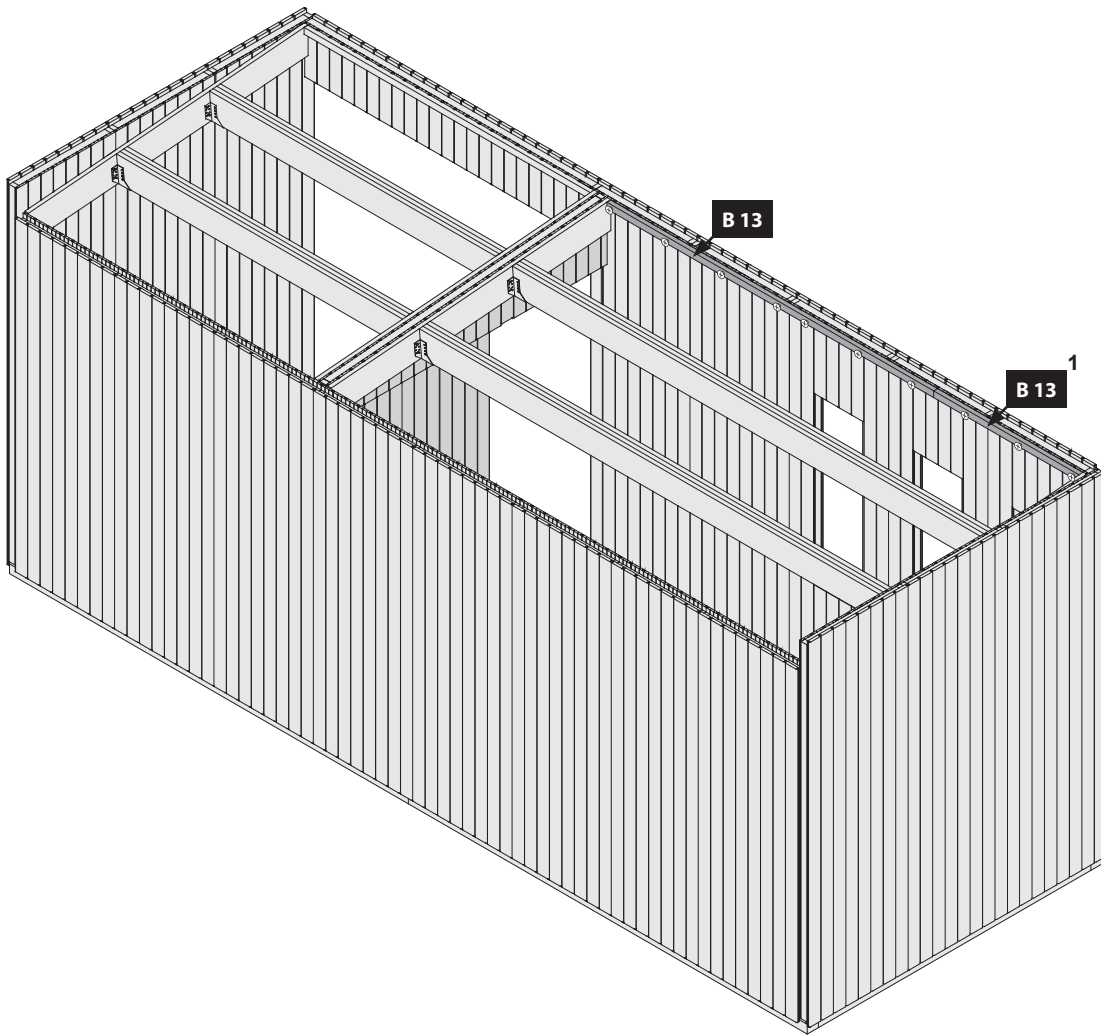



-  Schmale Seite nach oben
-  Narrow side up
-  Narrow vers le haut
-  Smal side op
-  Smalle kant boven
-  Estrecha hacia arriba

-  Stretta verso l'alto
-  Úzká stranou nahoru
-  Ozka stran navzgor

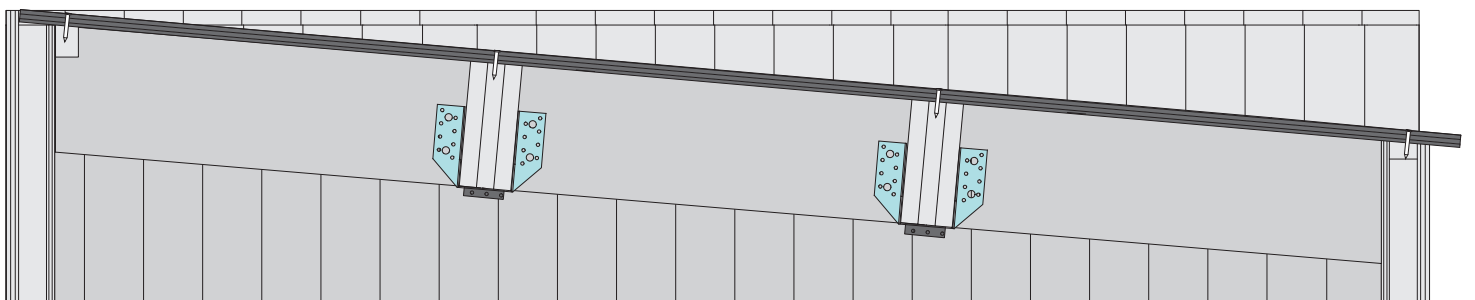
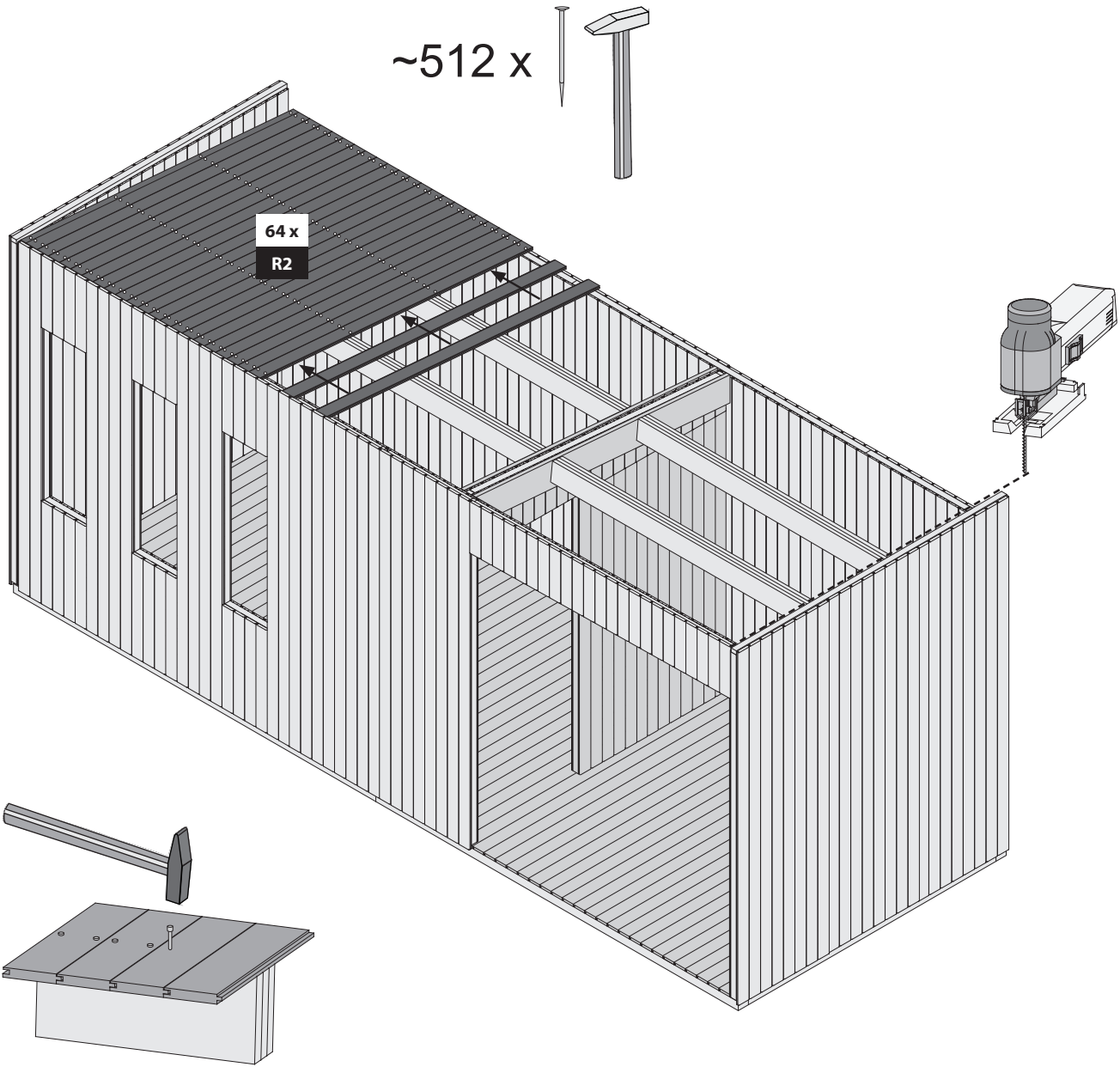
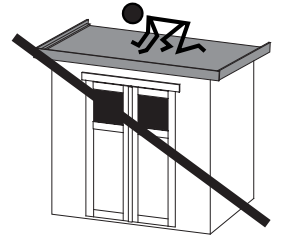
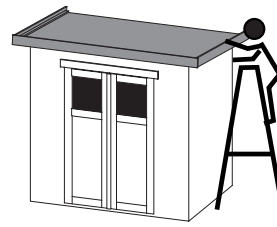

23

3x

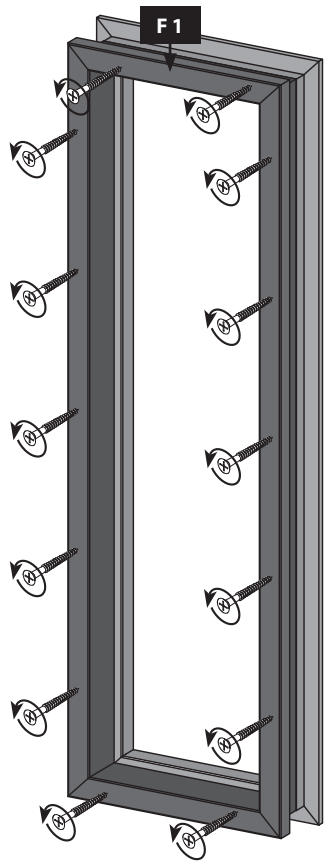

24

3x

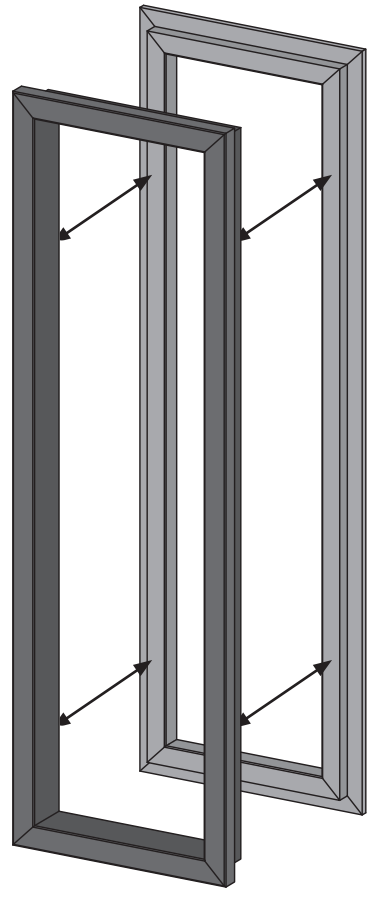

25

3x

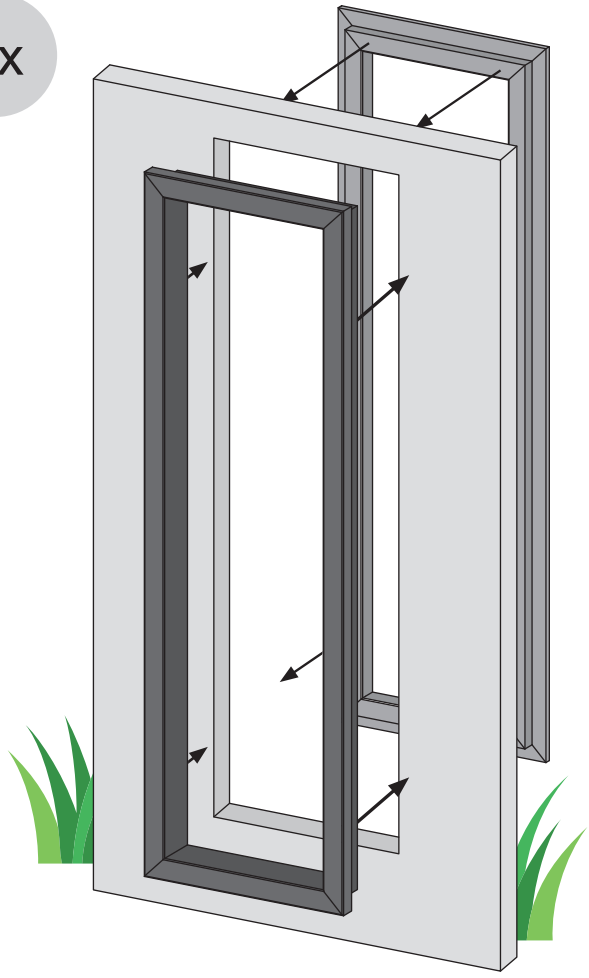

26

3x

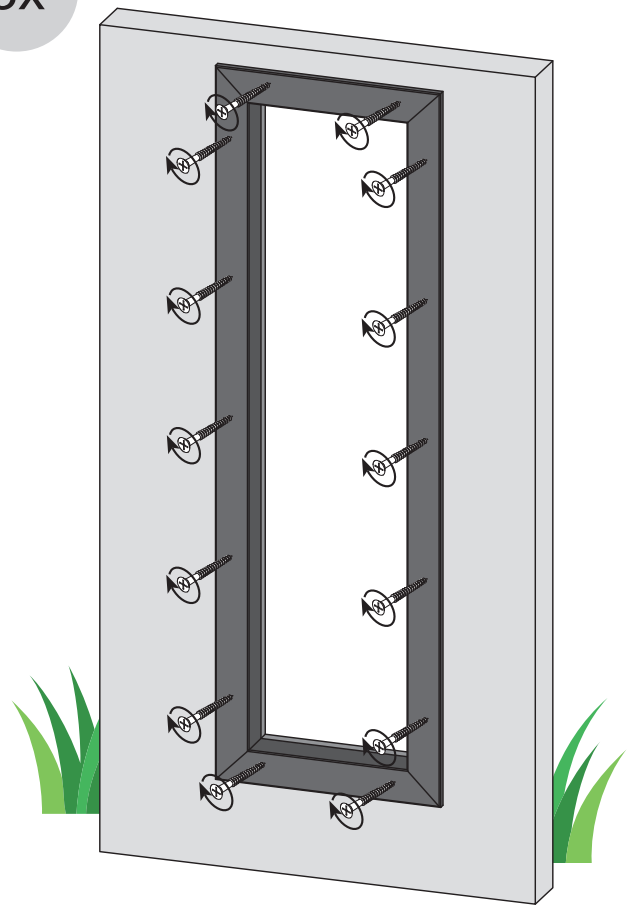

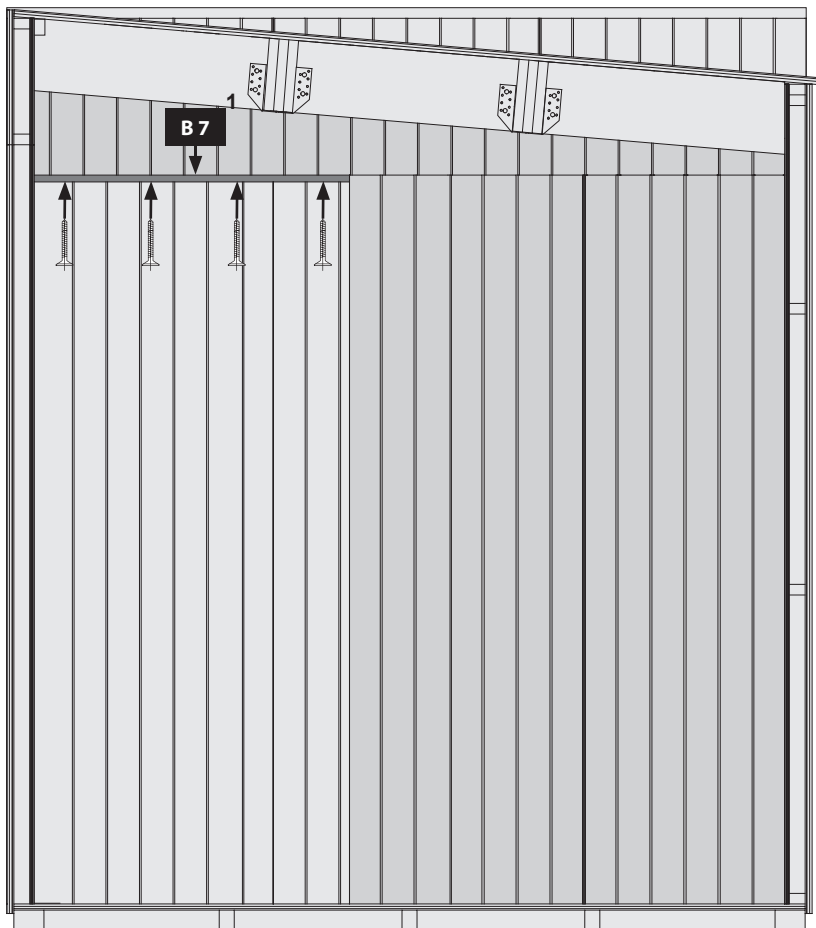
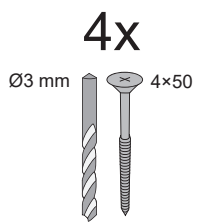
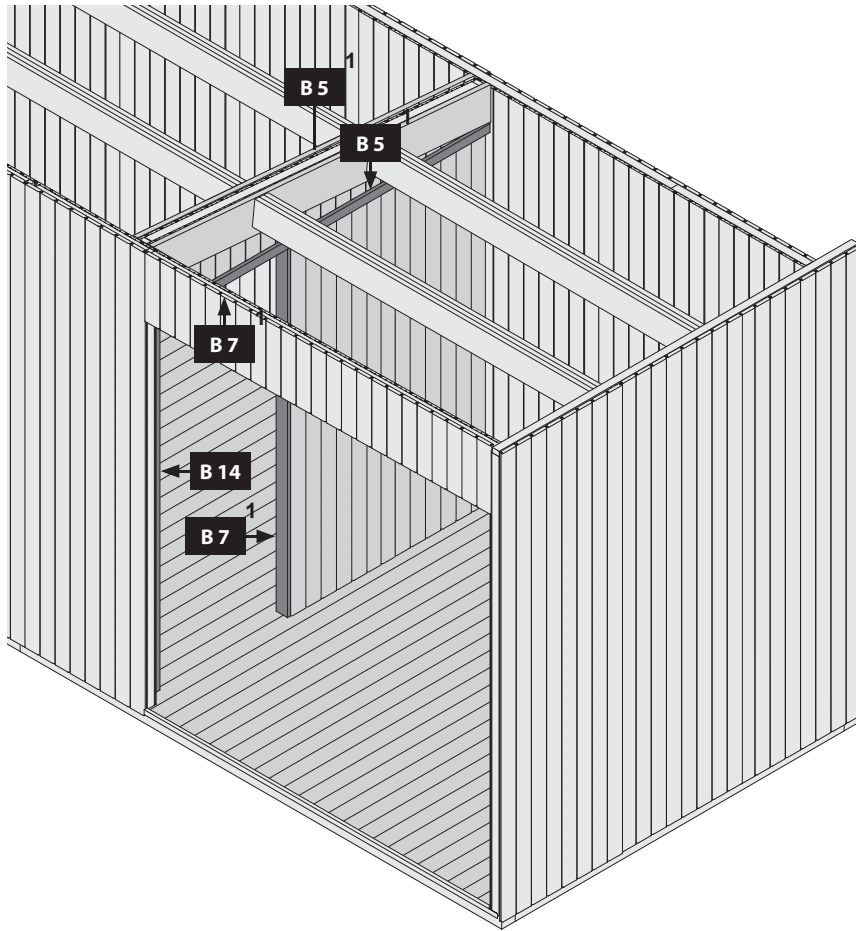

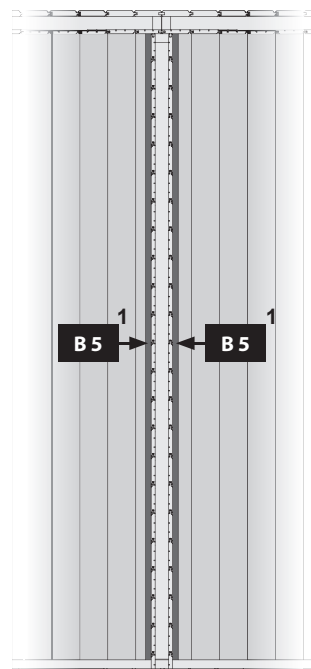
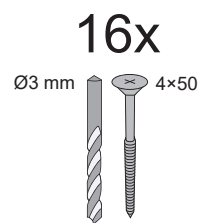
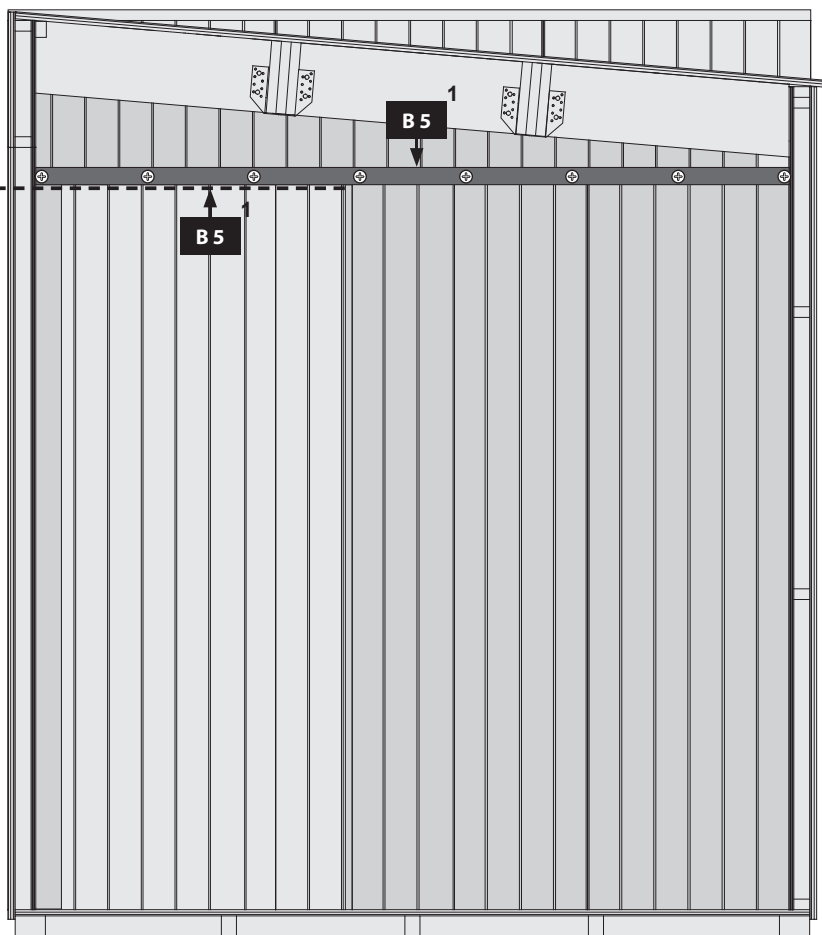
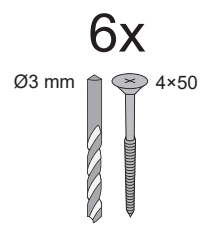
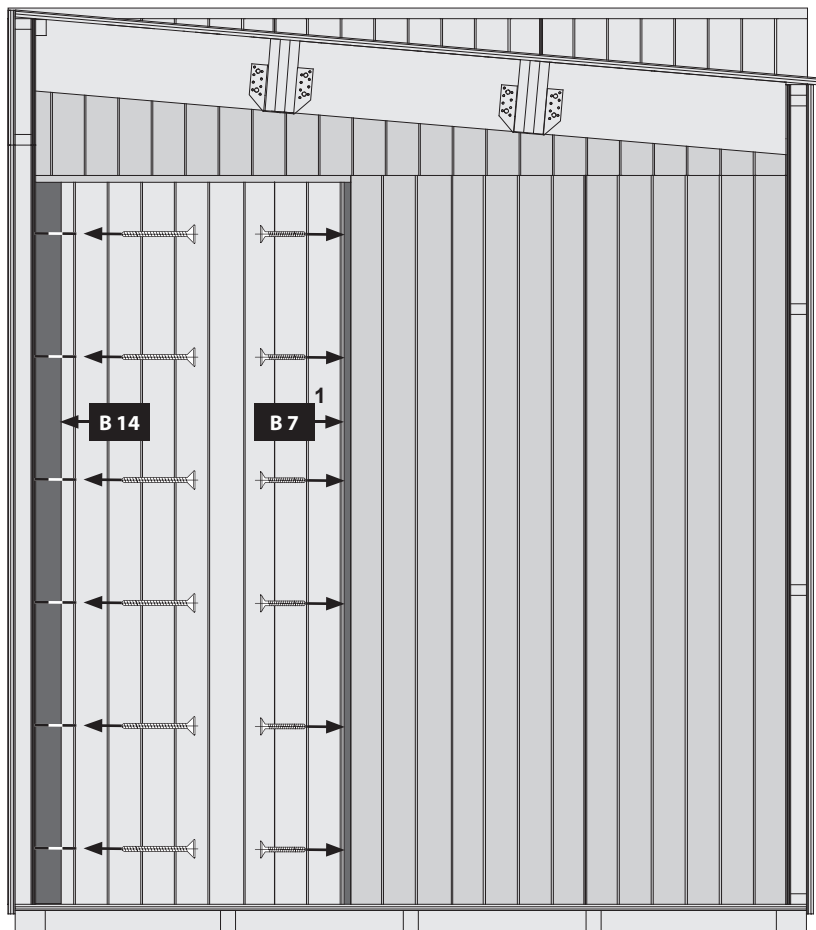
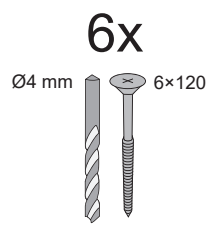

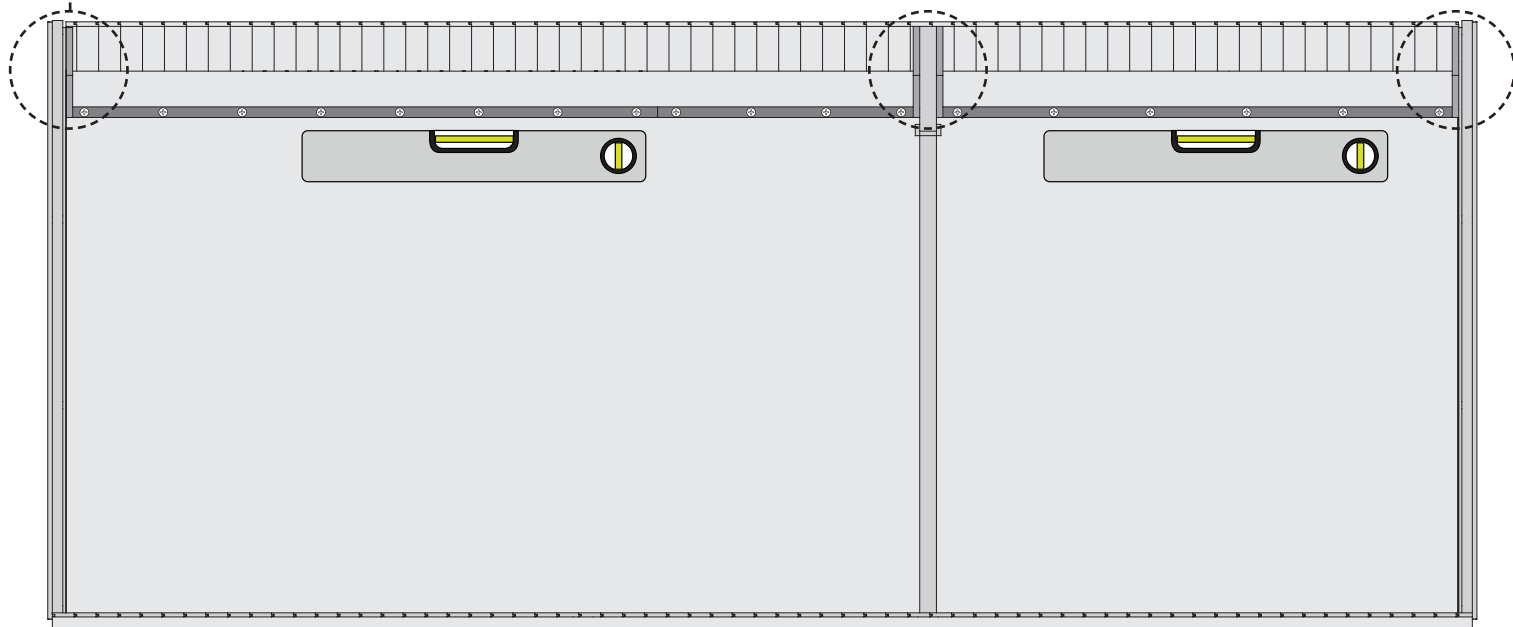
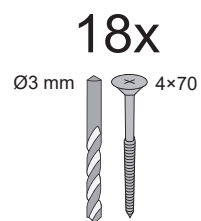
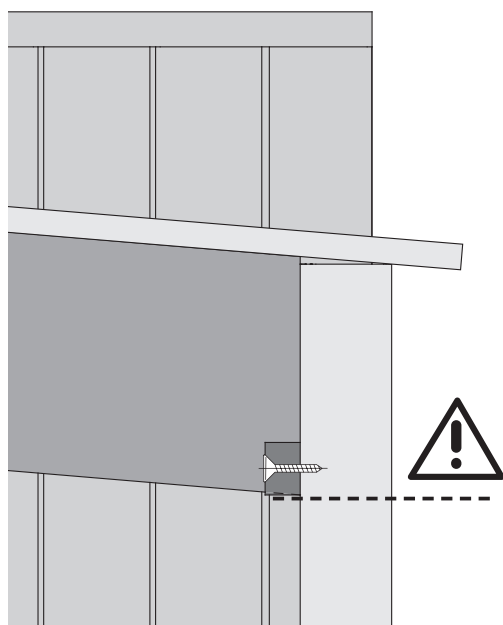
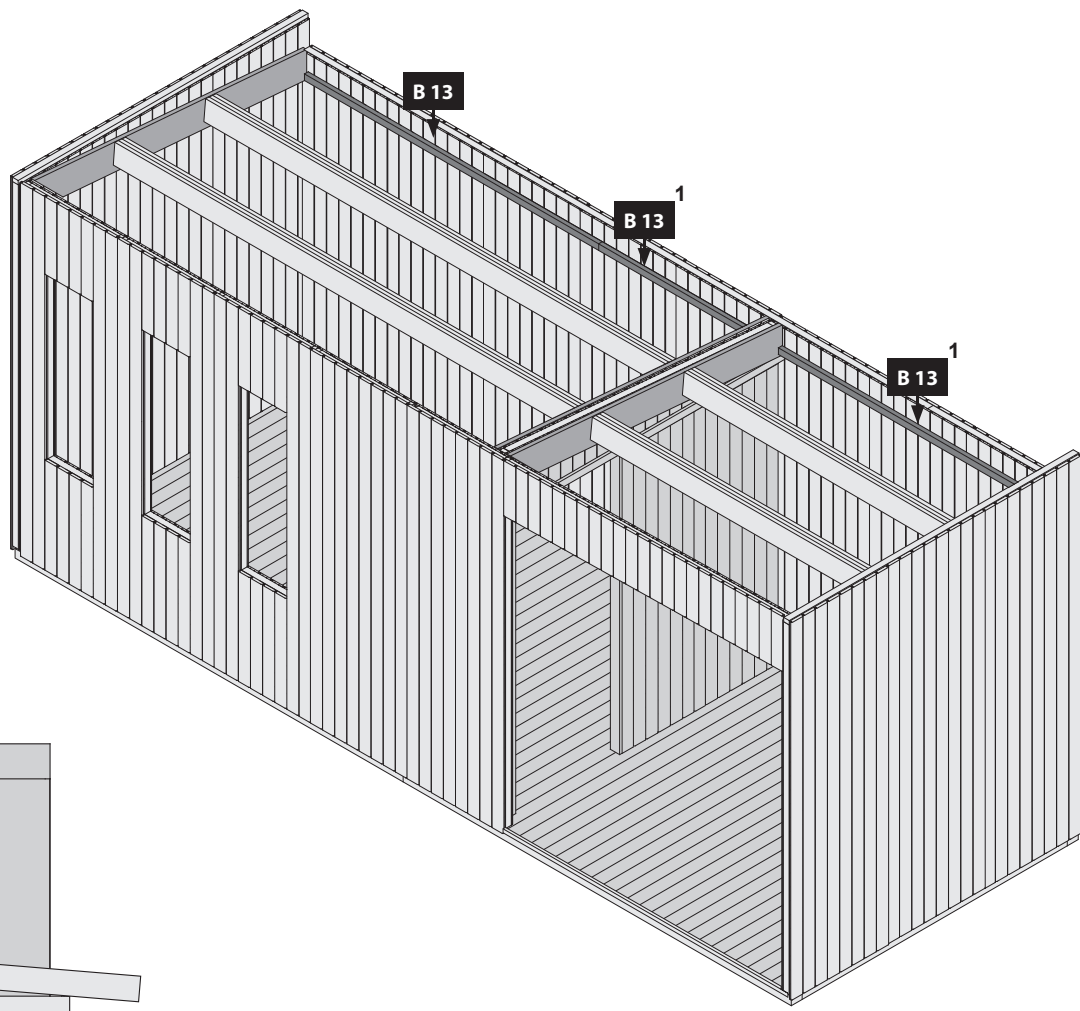

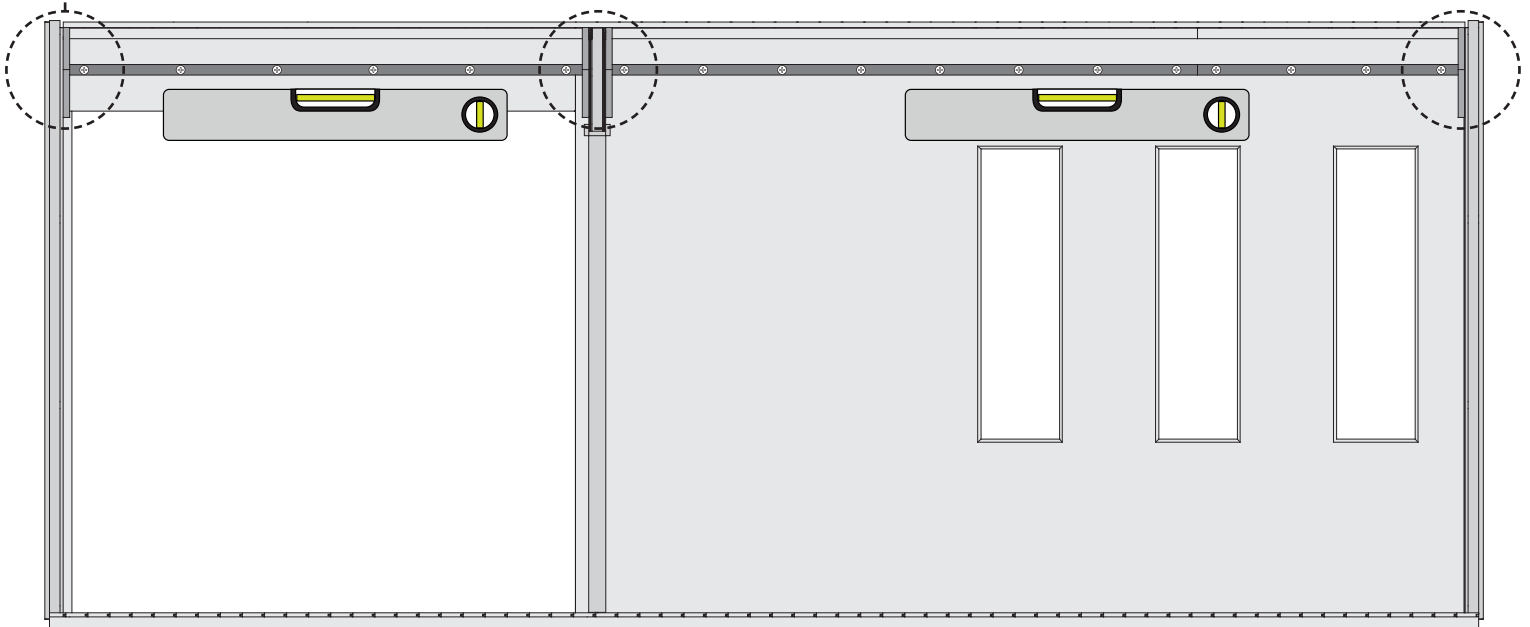
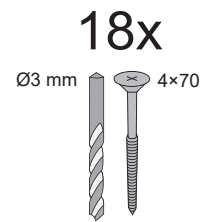
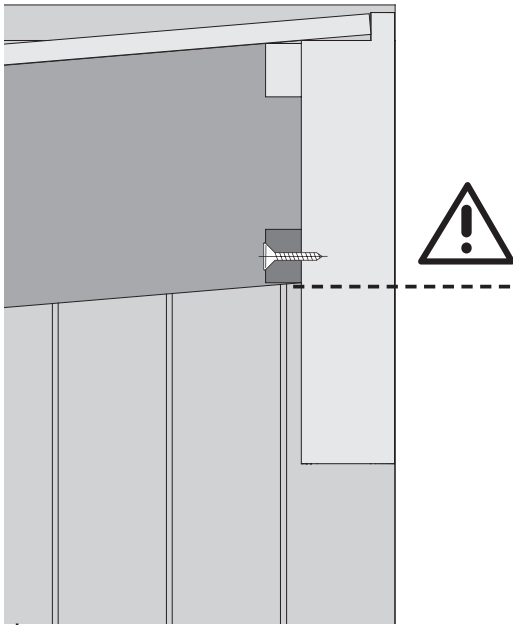
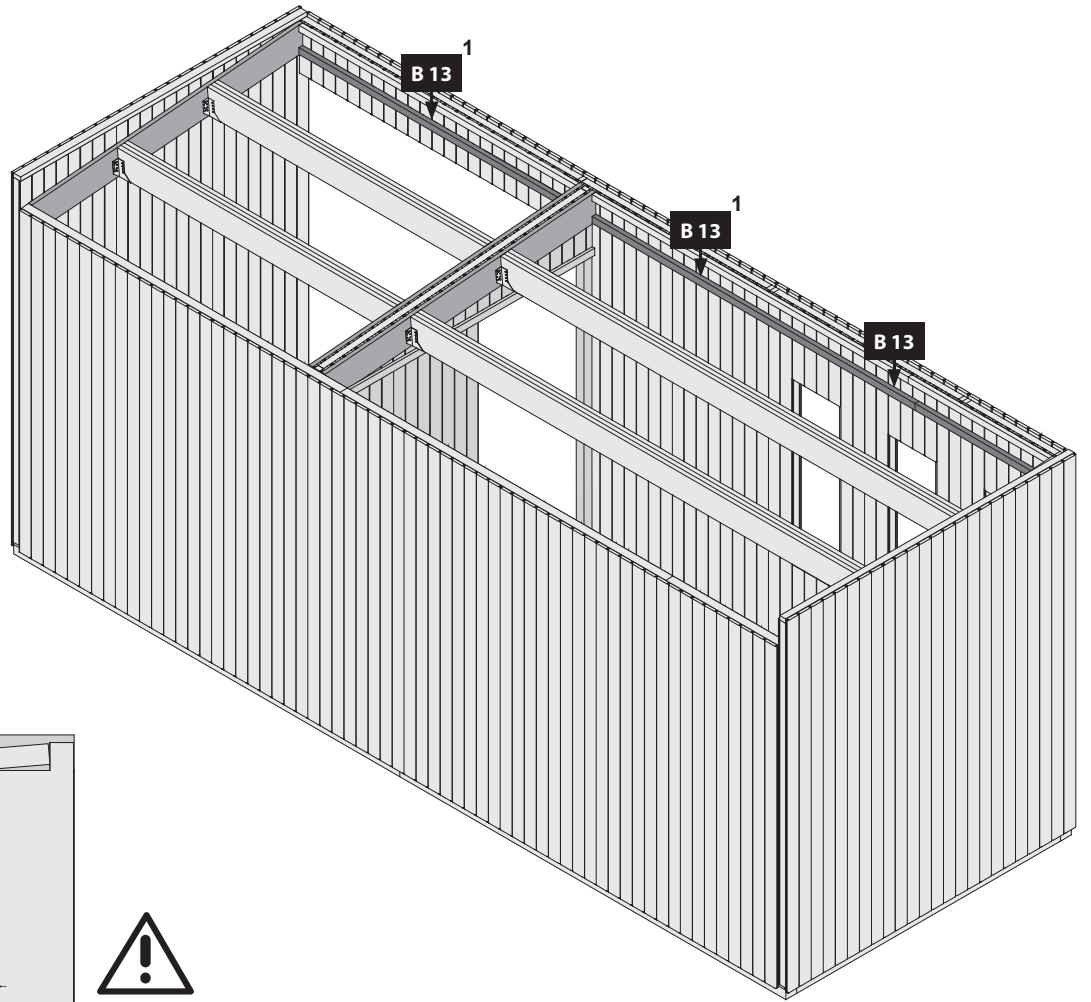

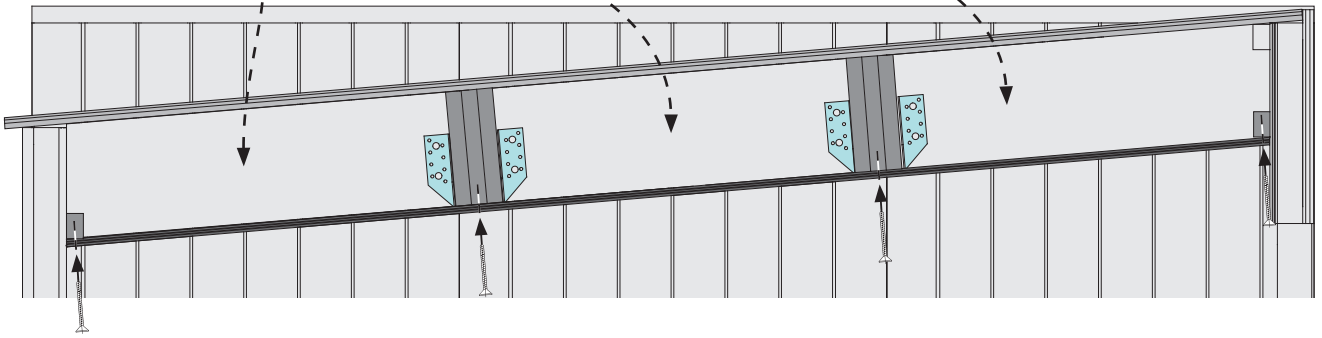
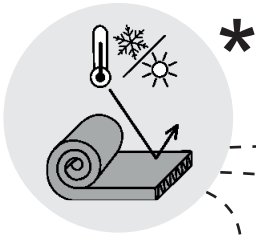

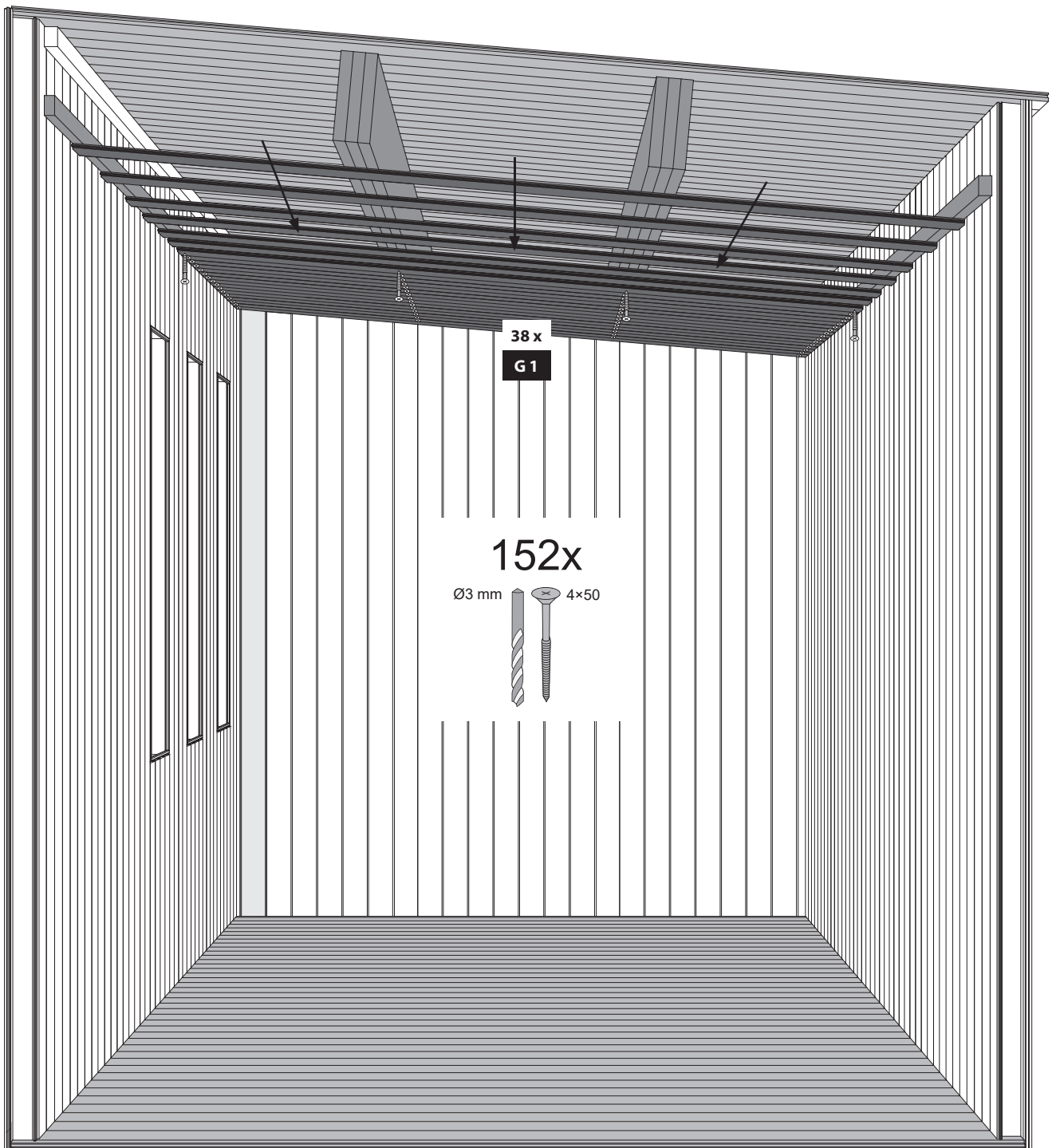
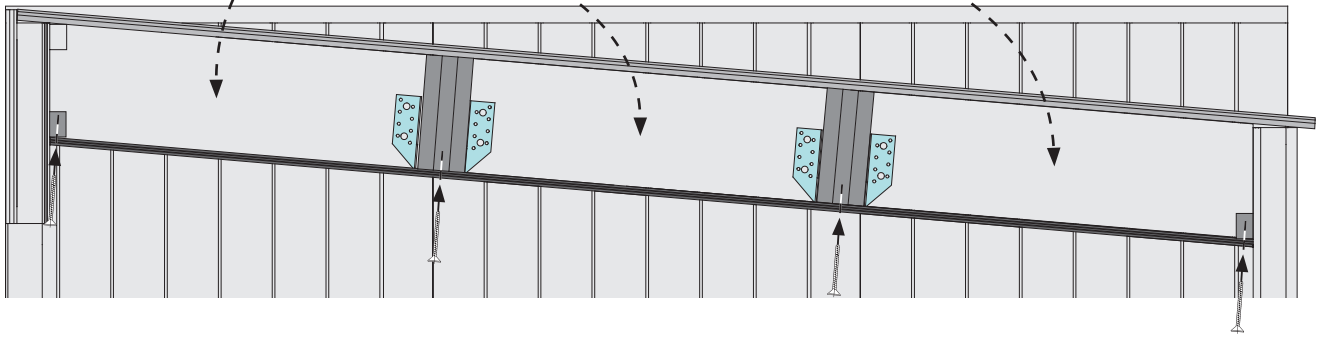
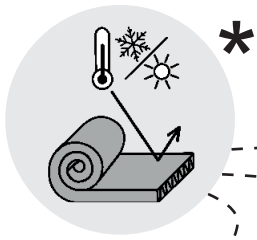

38 x
G1

152x

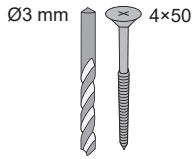

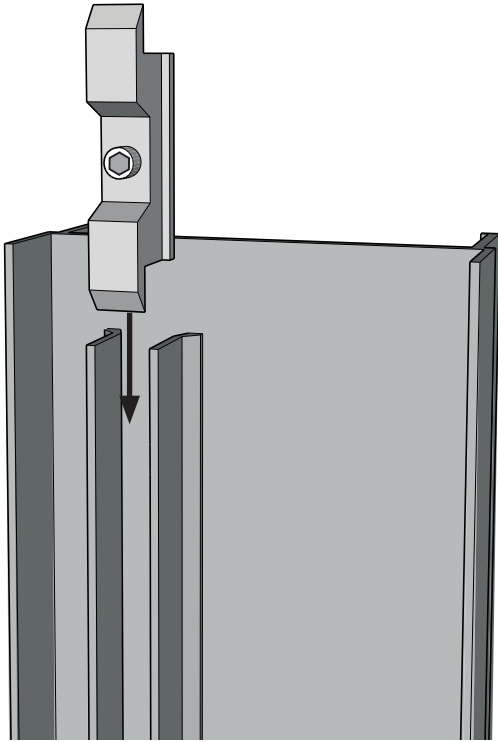

34 A

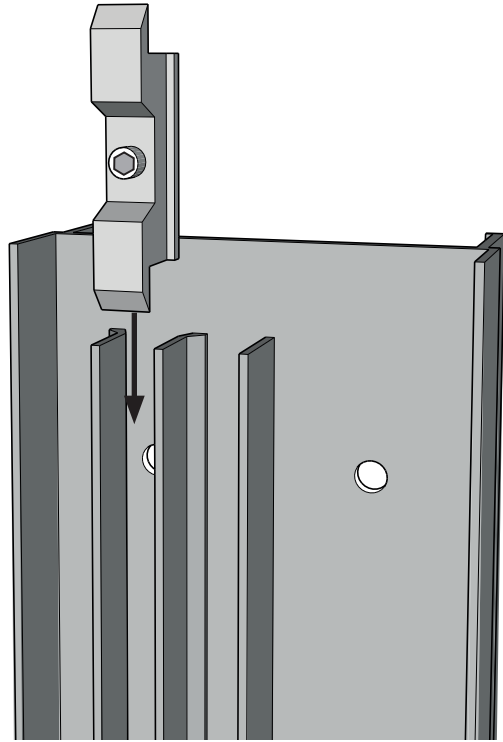

34 B

34 A

2x

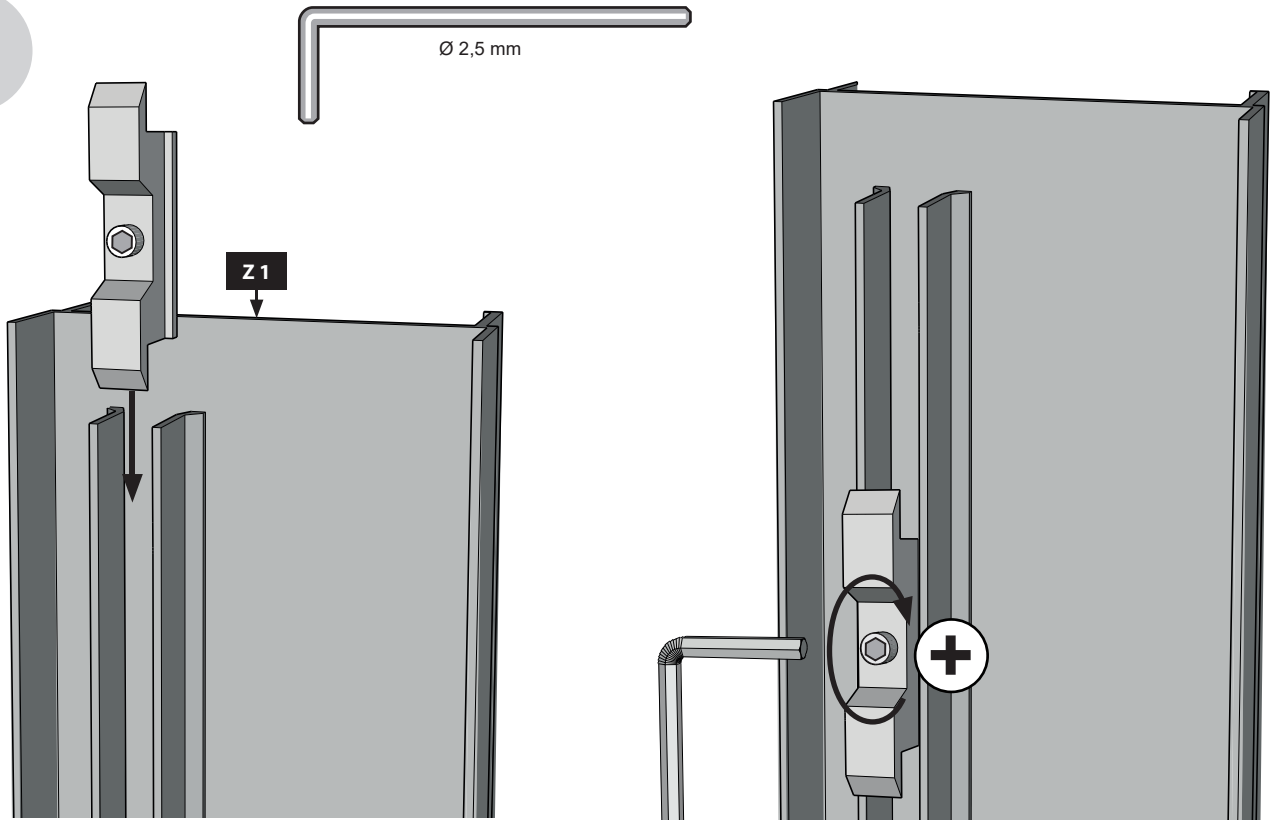

35 A

$\text{Ø}3\text{mm}$ 4x50
6x

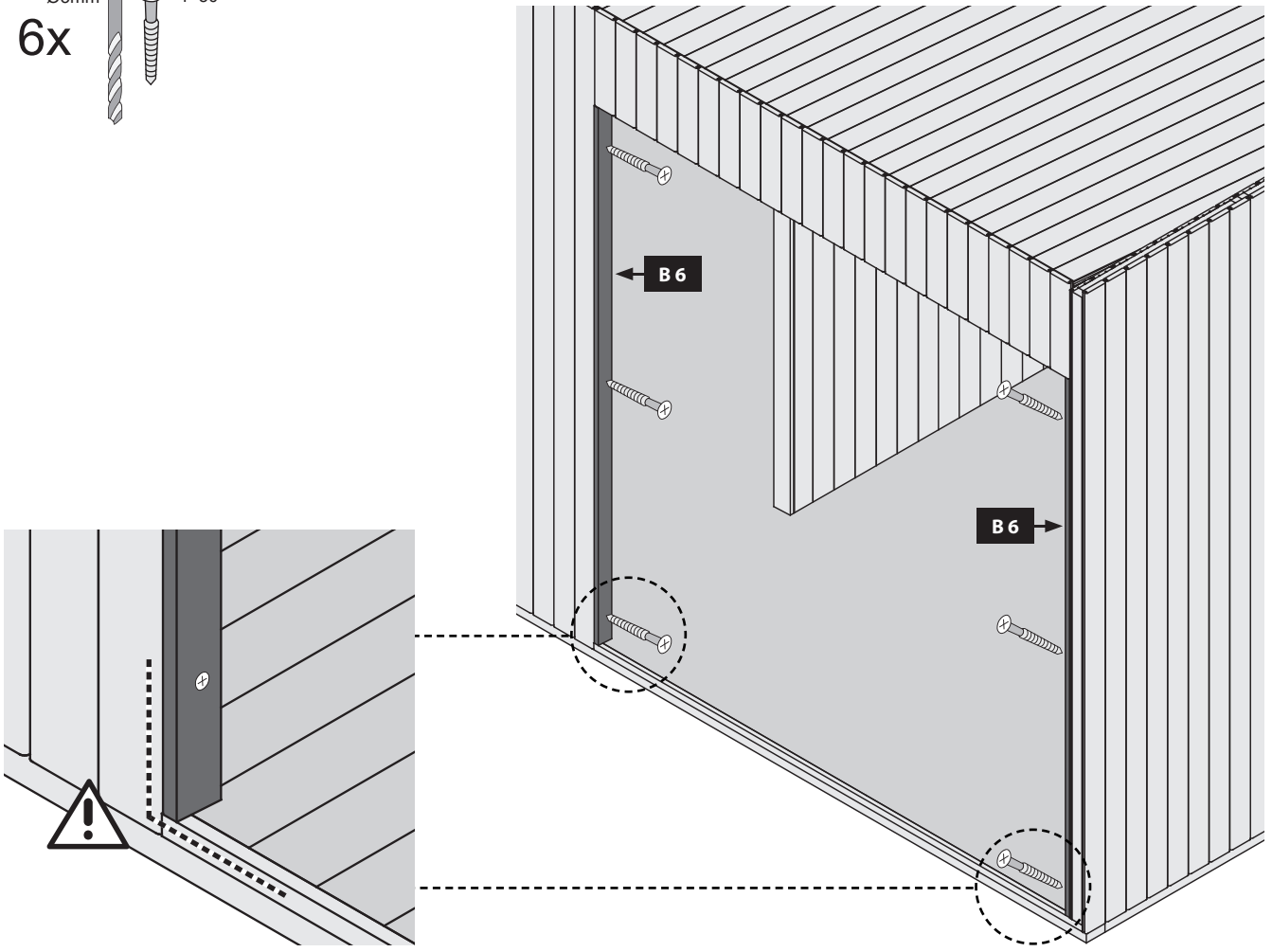

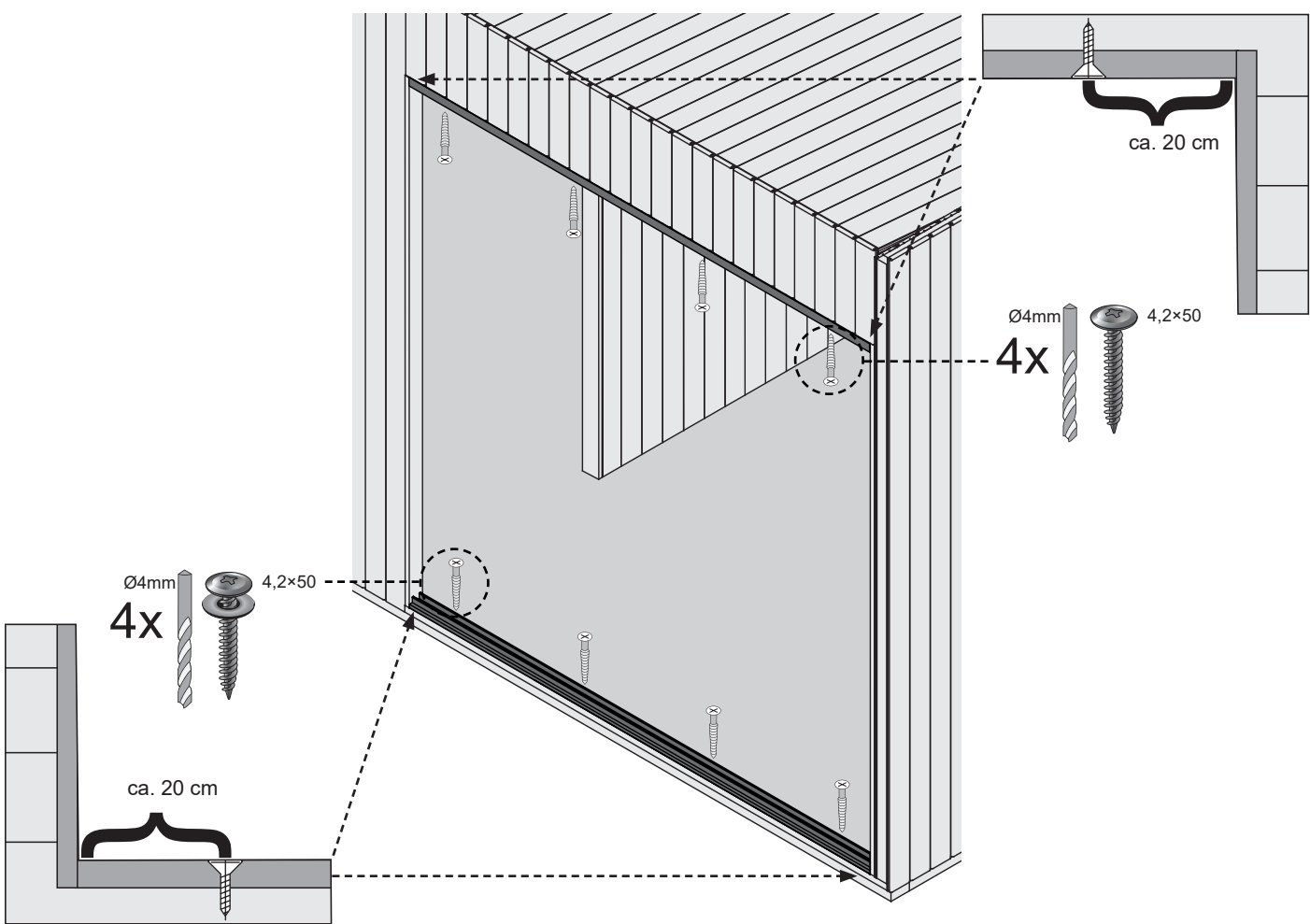
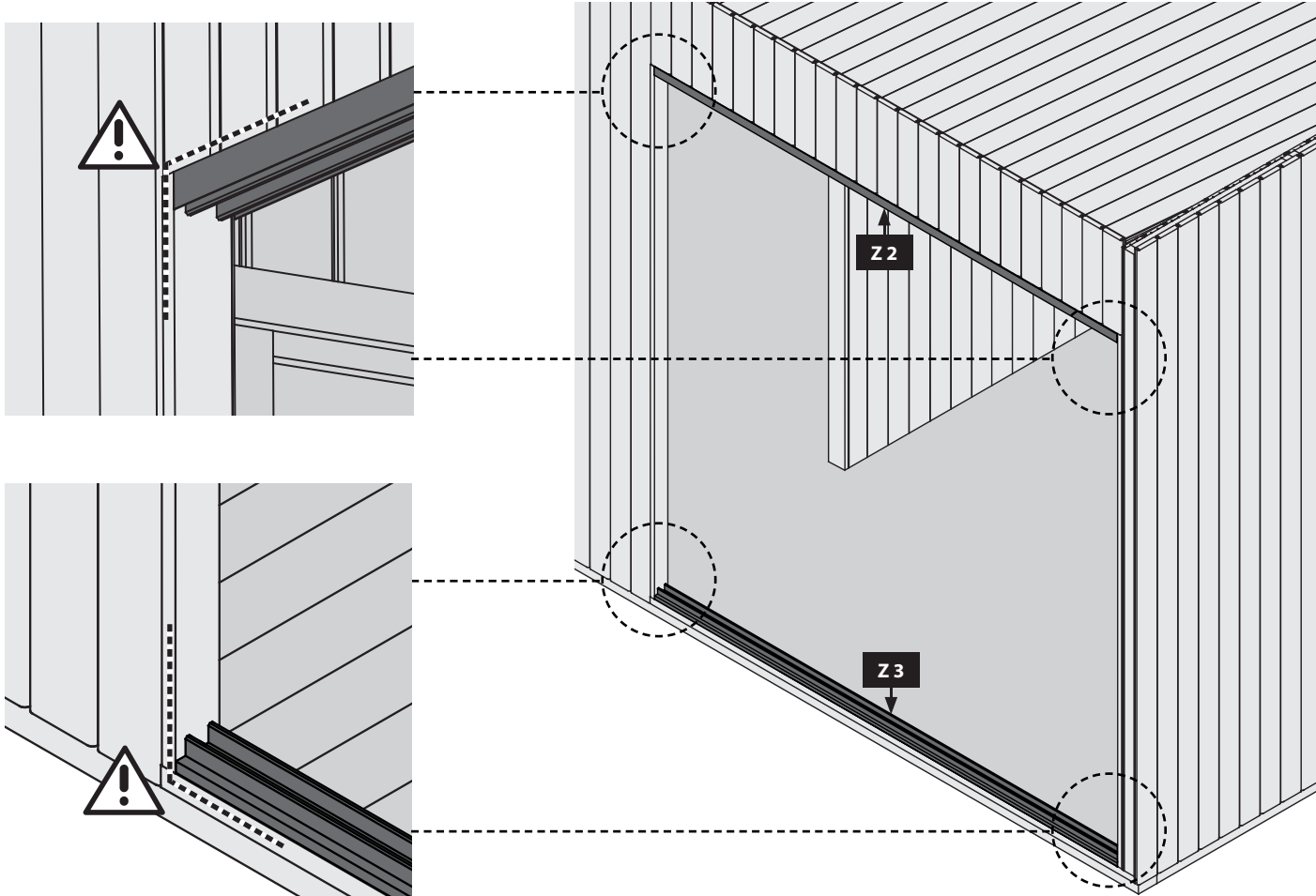

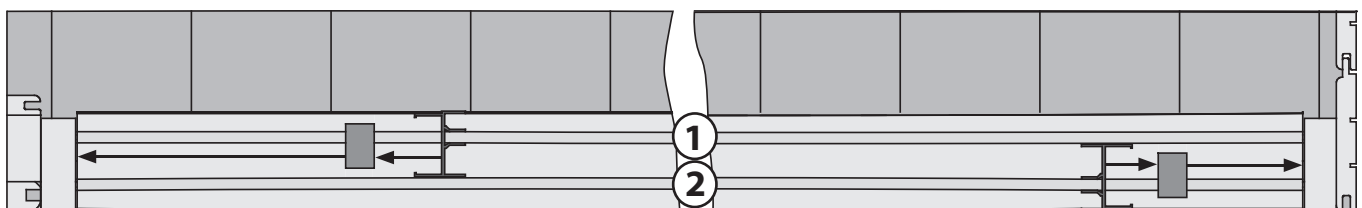
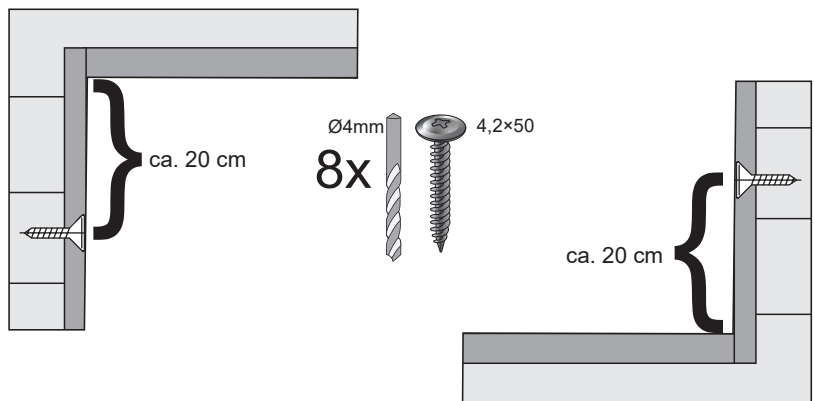
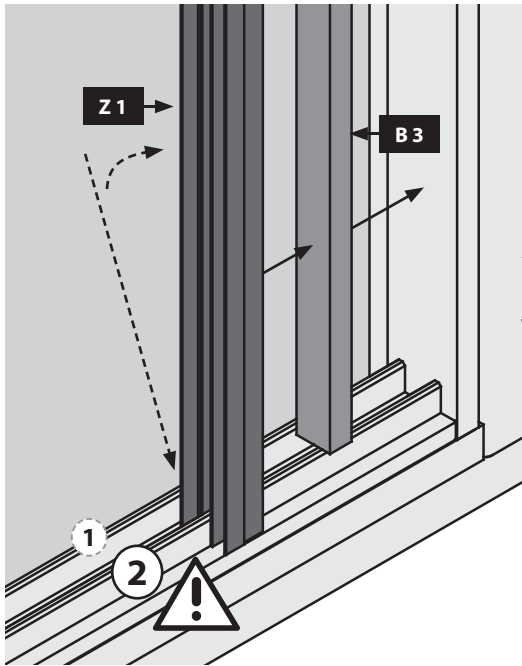
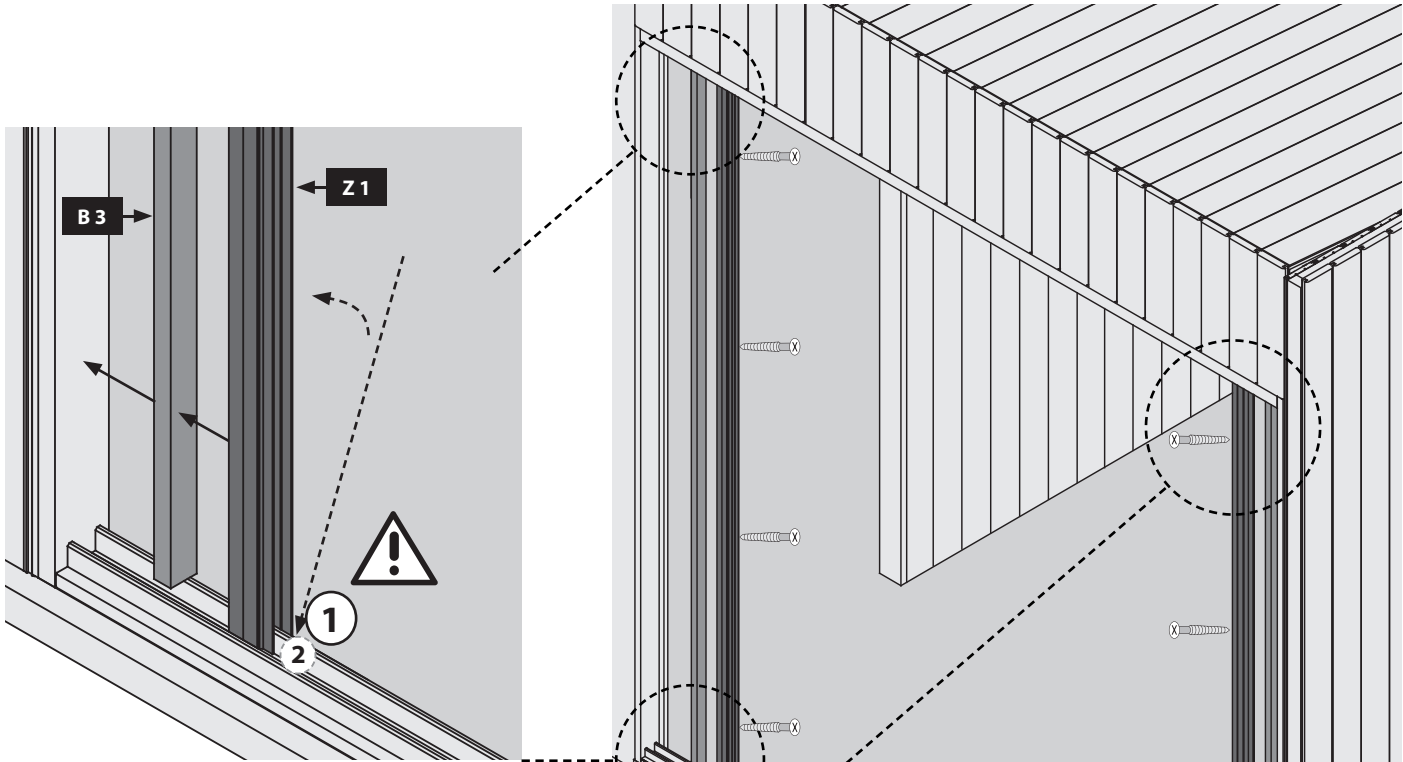

38 A

32x

Ø3 mm 4x50

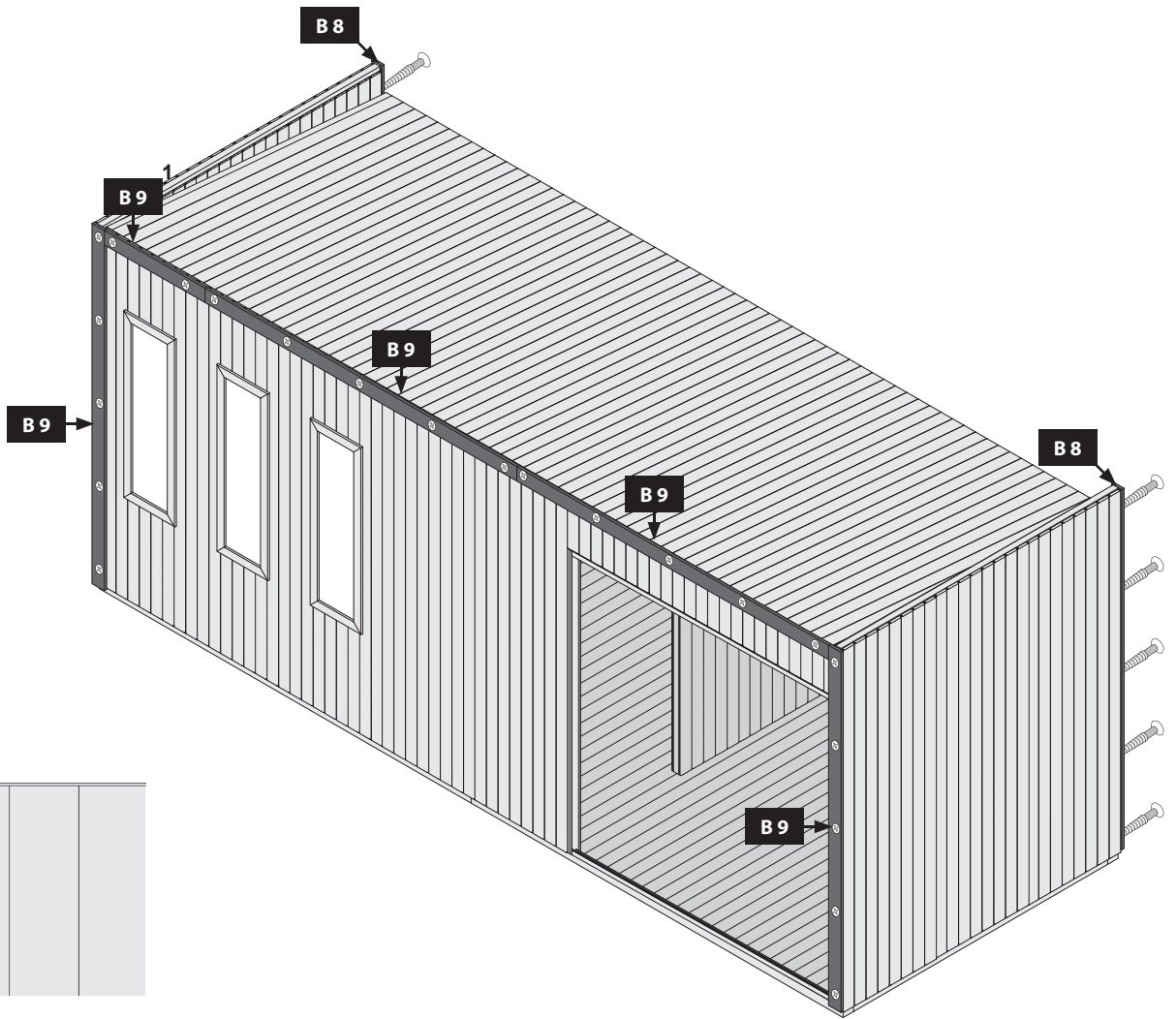
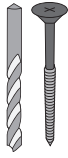

39 A

10x

Ø3 mm 4x50

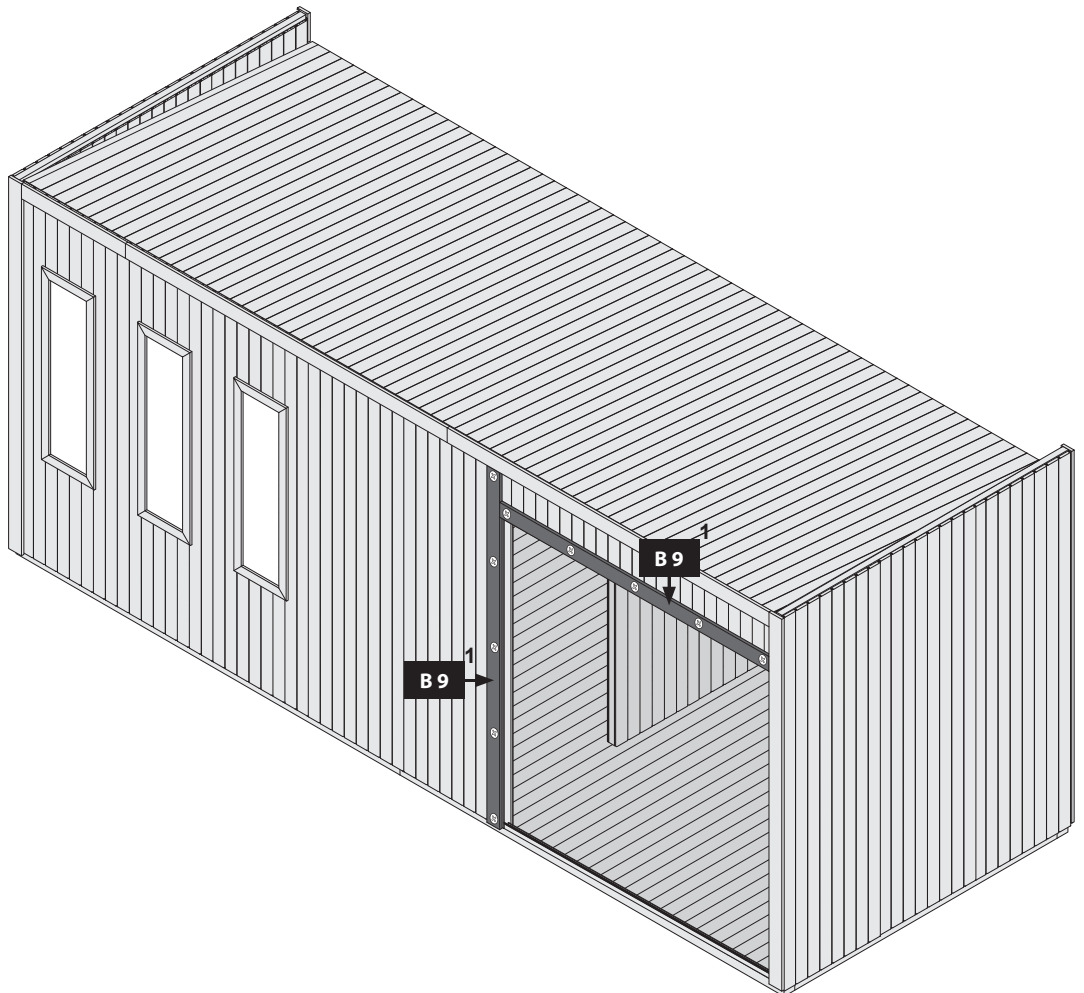
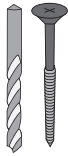

40 A

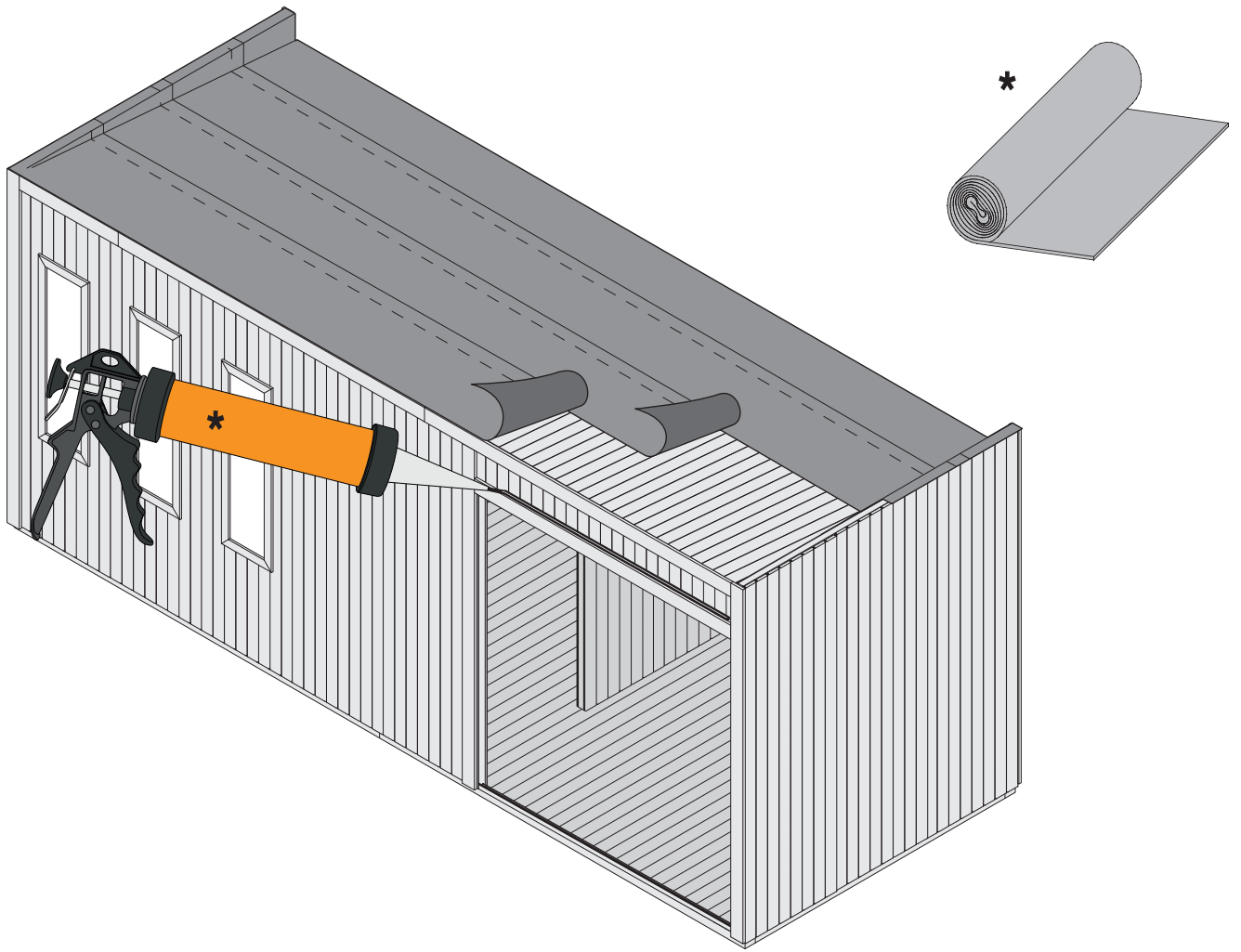

41 A

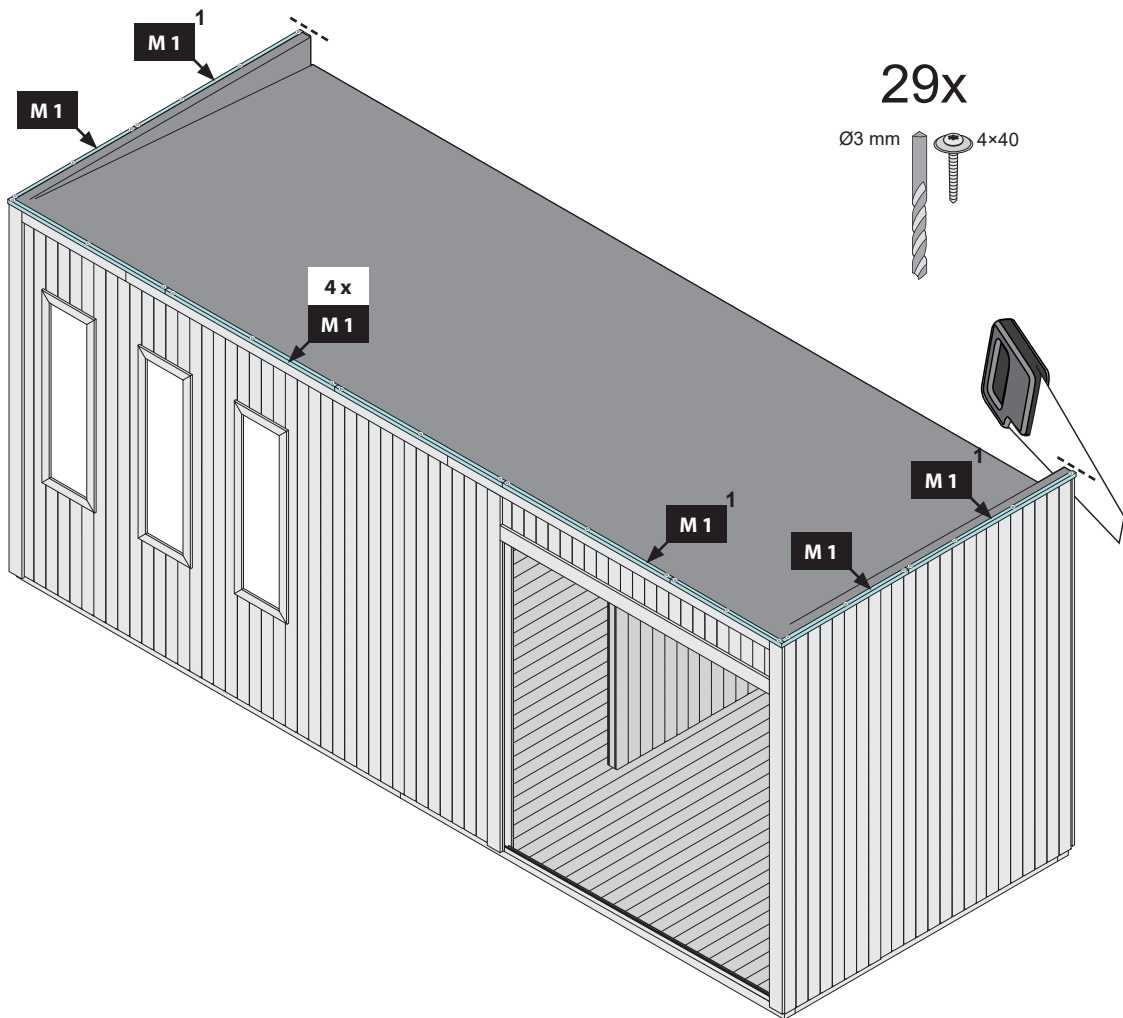

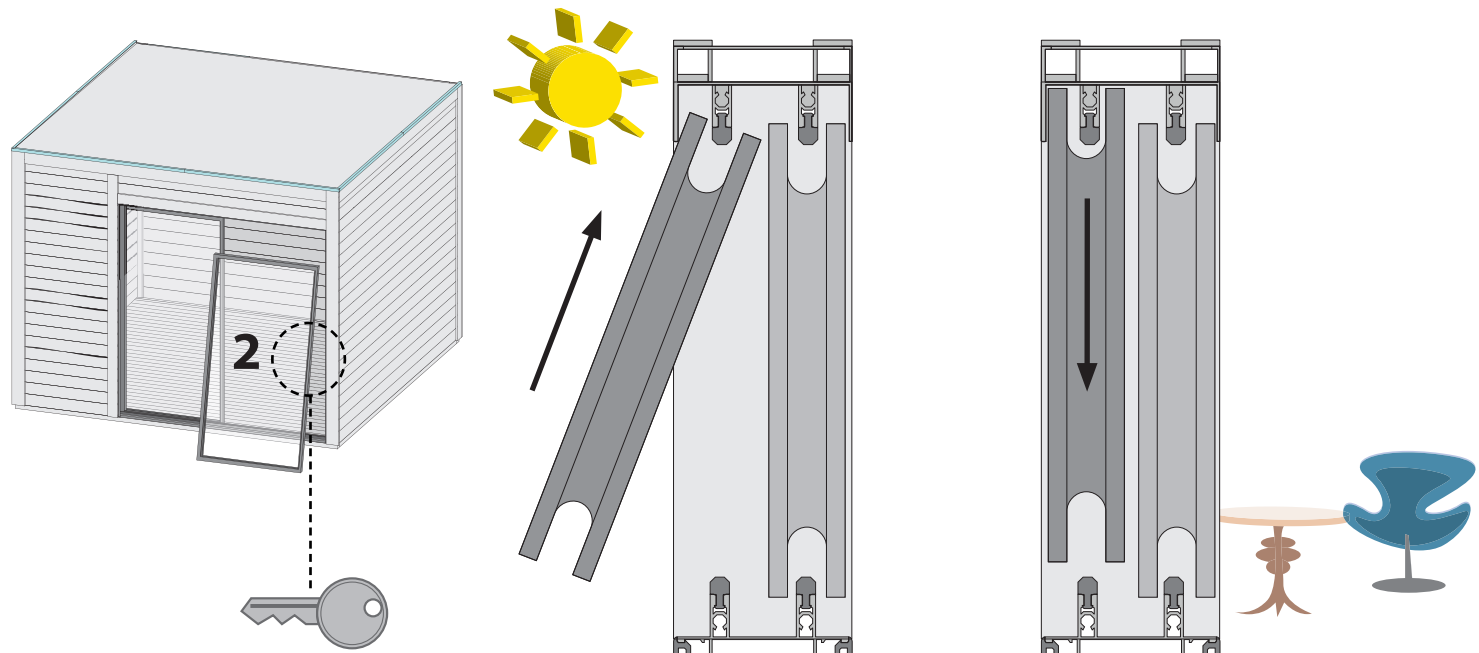
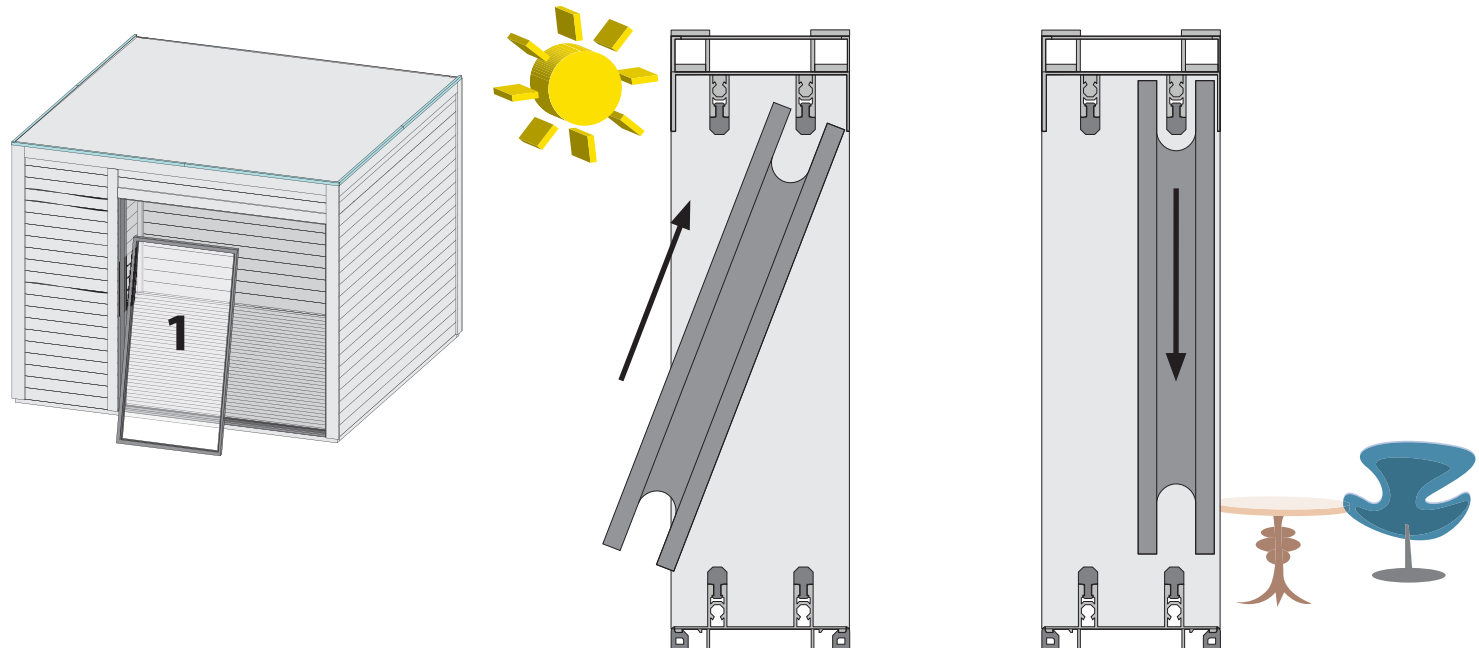
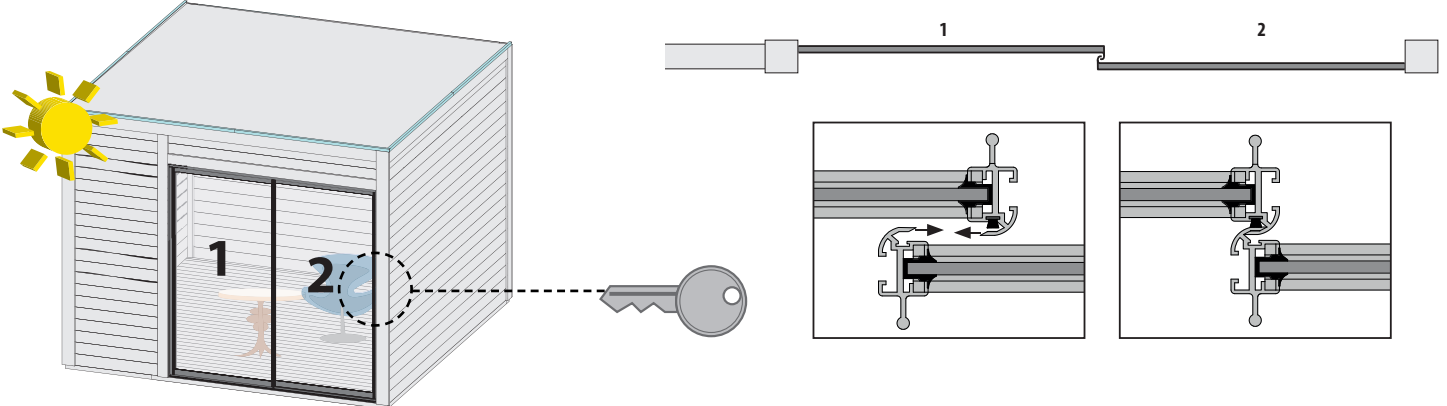

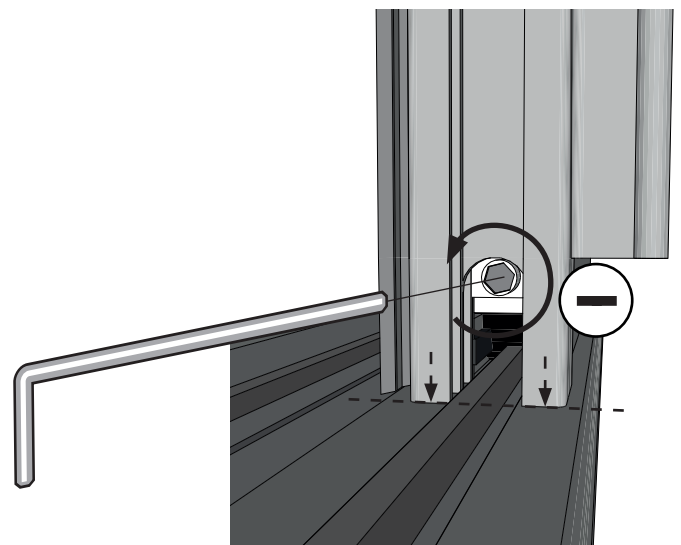
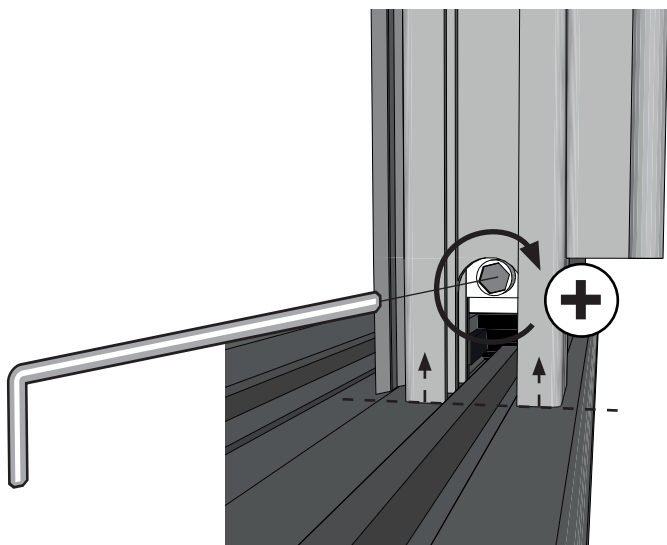
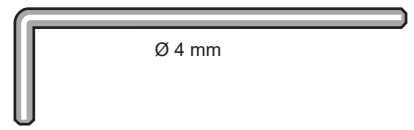
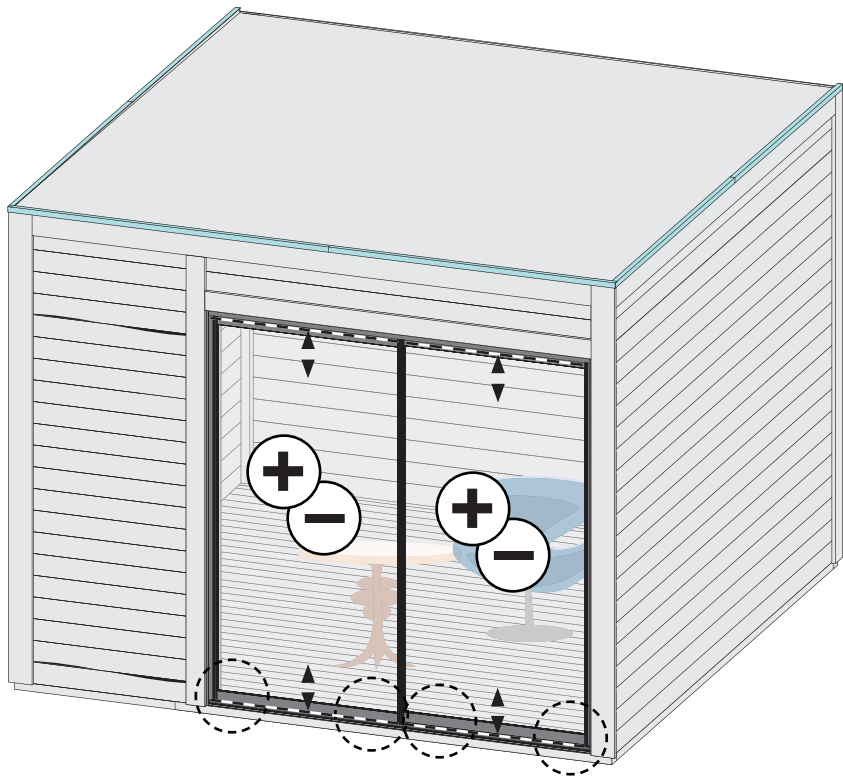

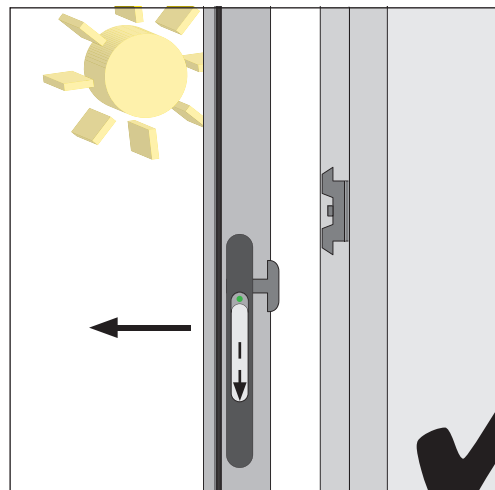
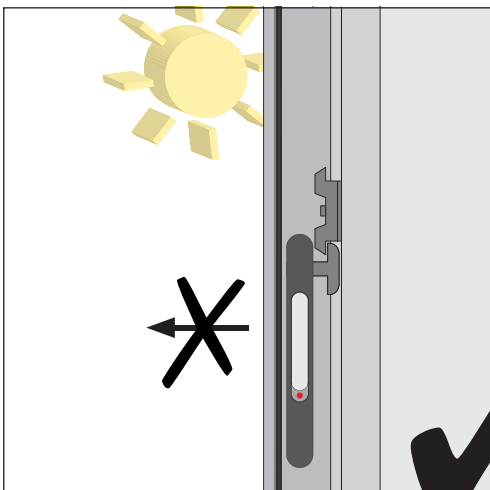
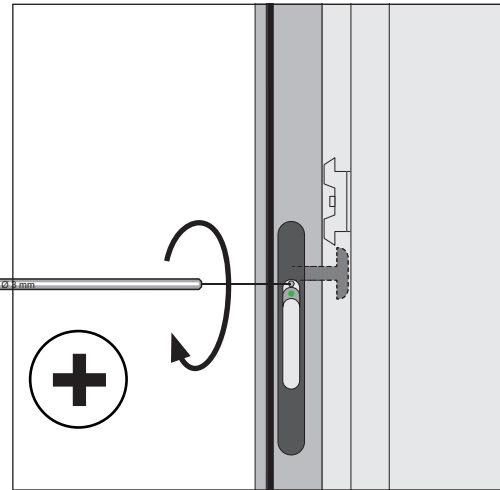
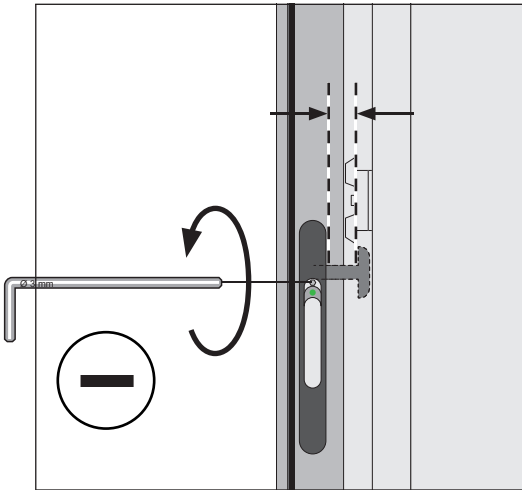
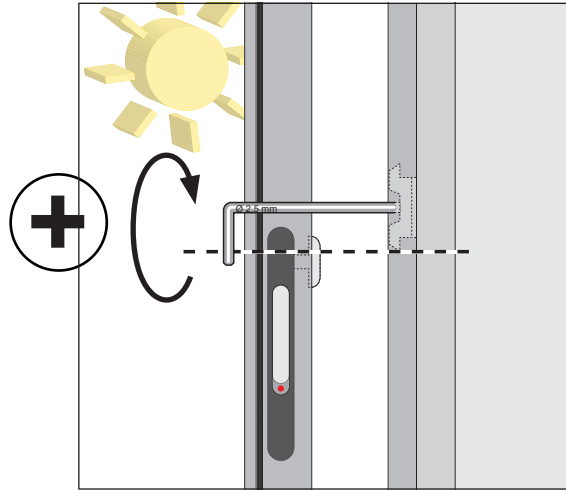
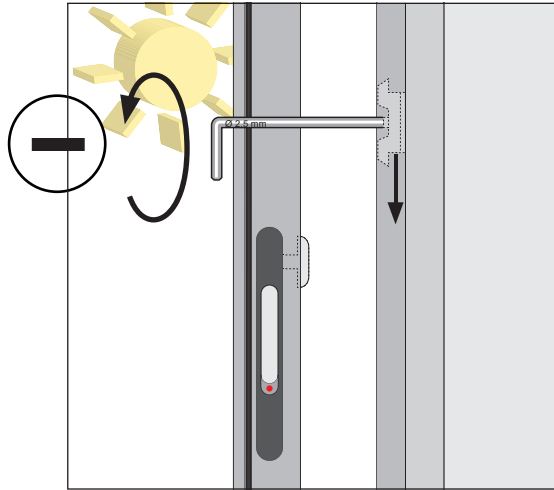
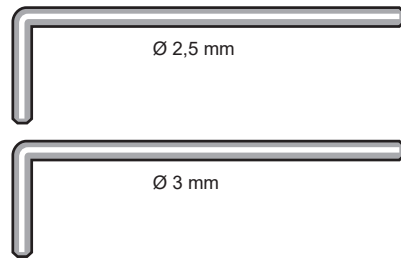
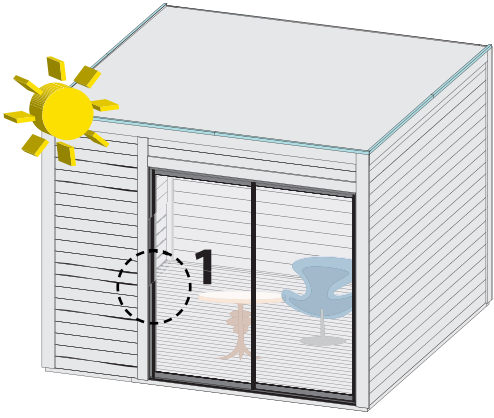

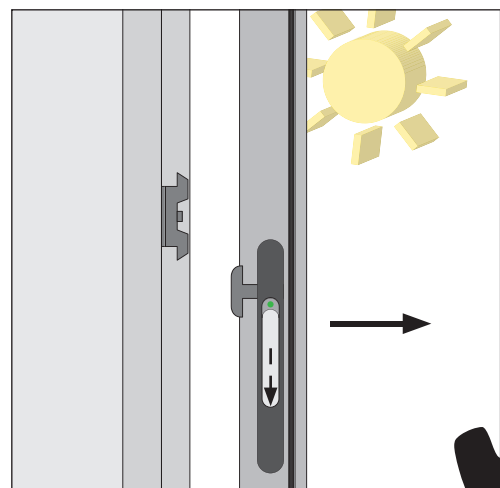
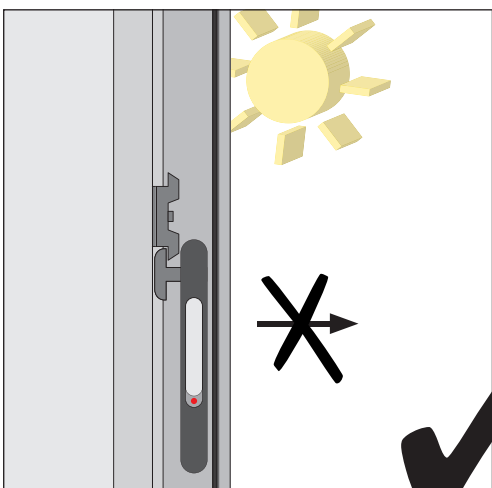
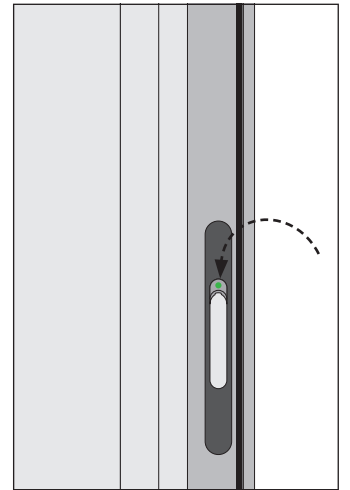
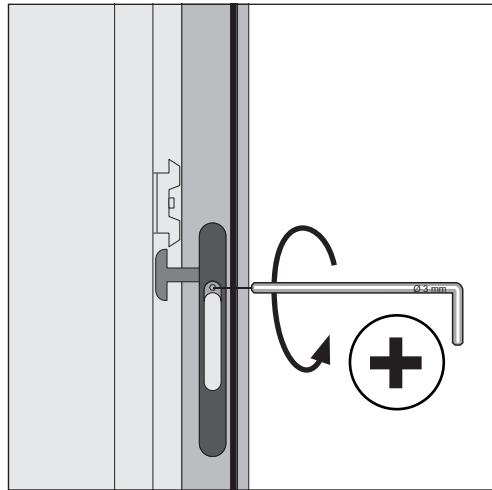
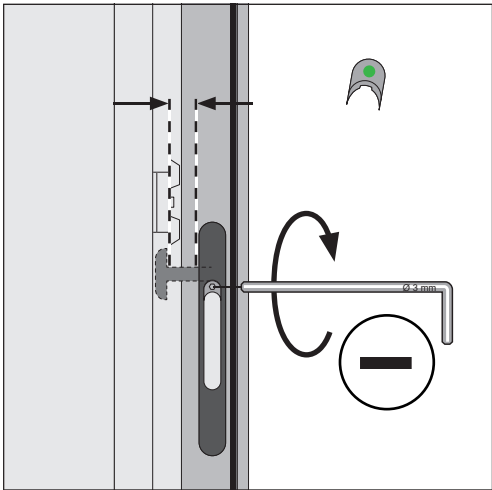
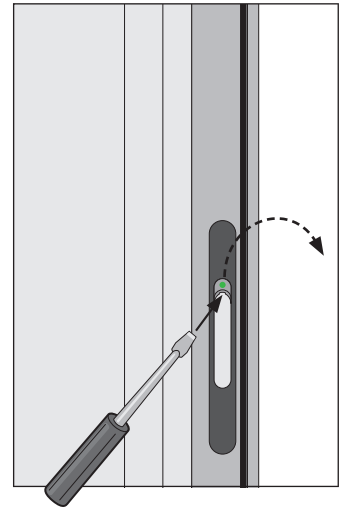
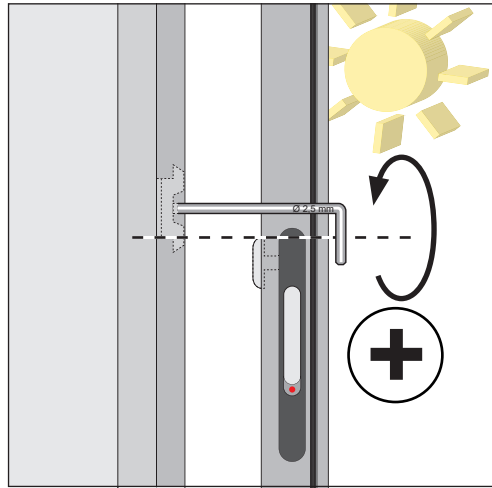
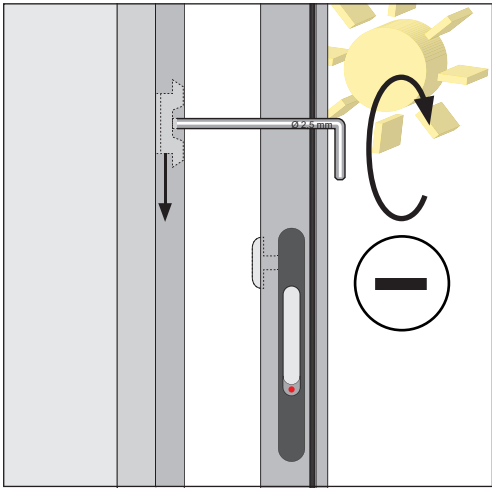
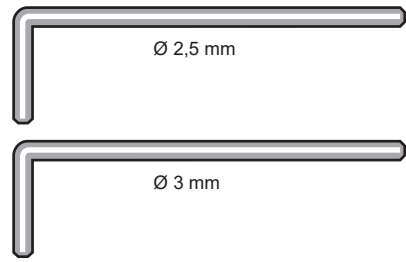
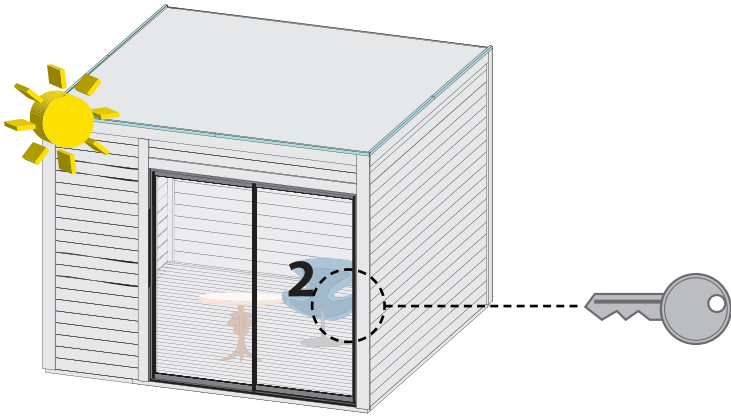

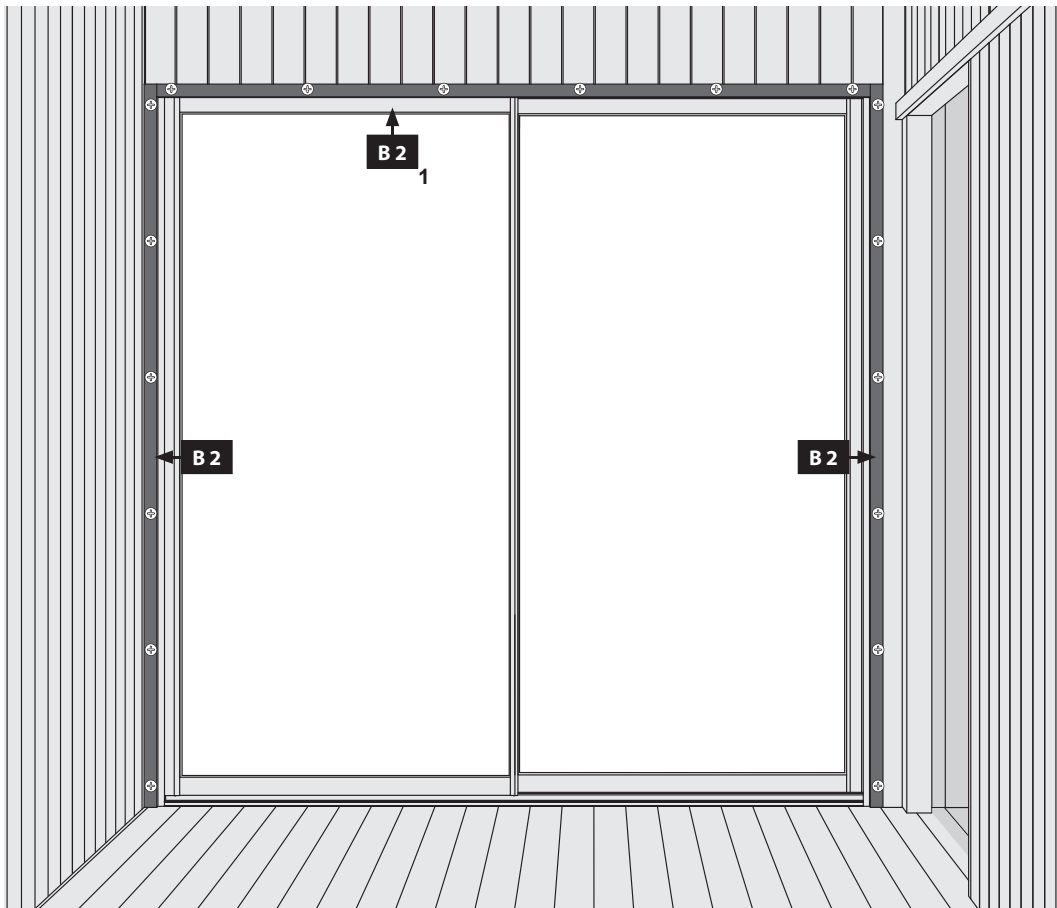

18x

Ø3 mm 4x50

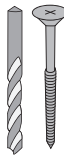

34 B

2x

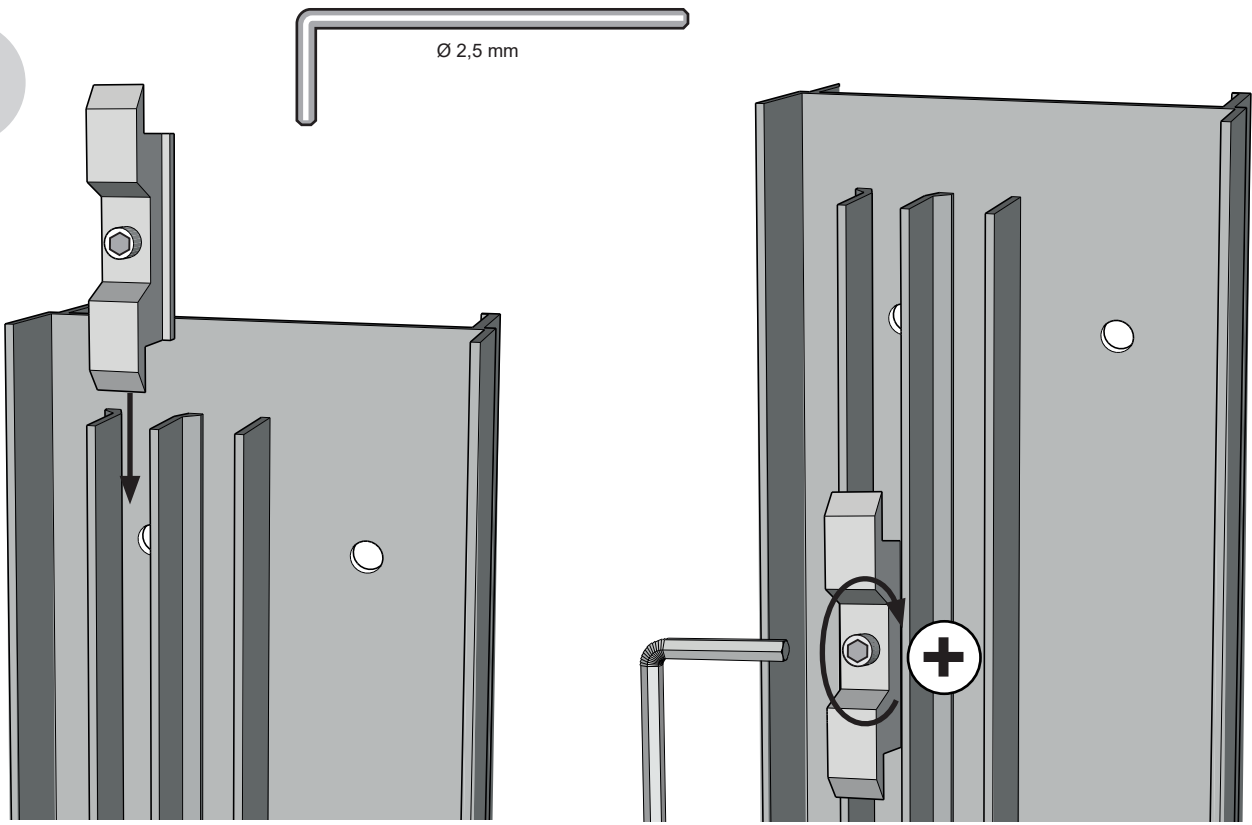

35 B

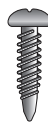
16x  4,8x32

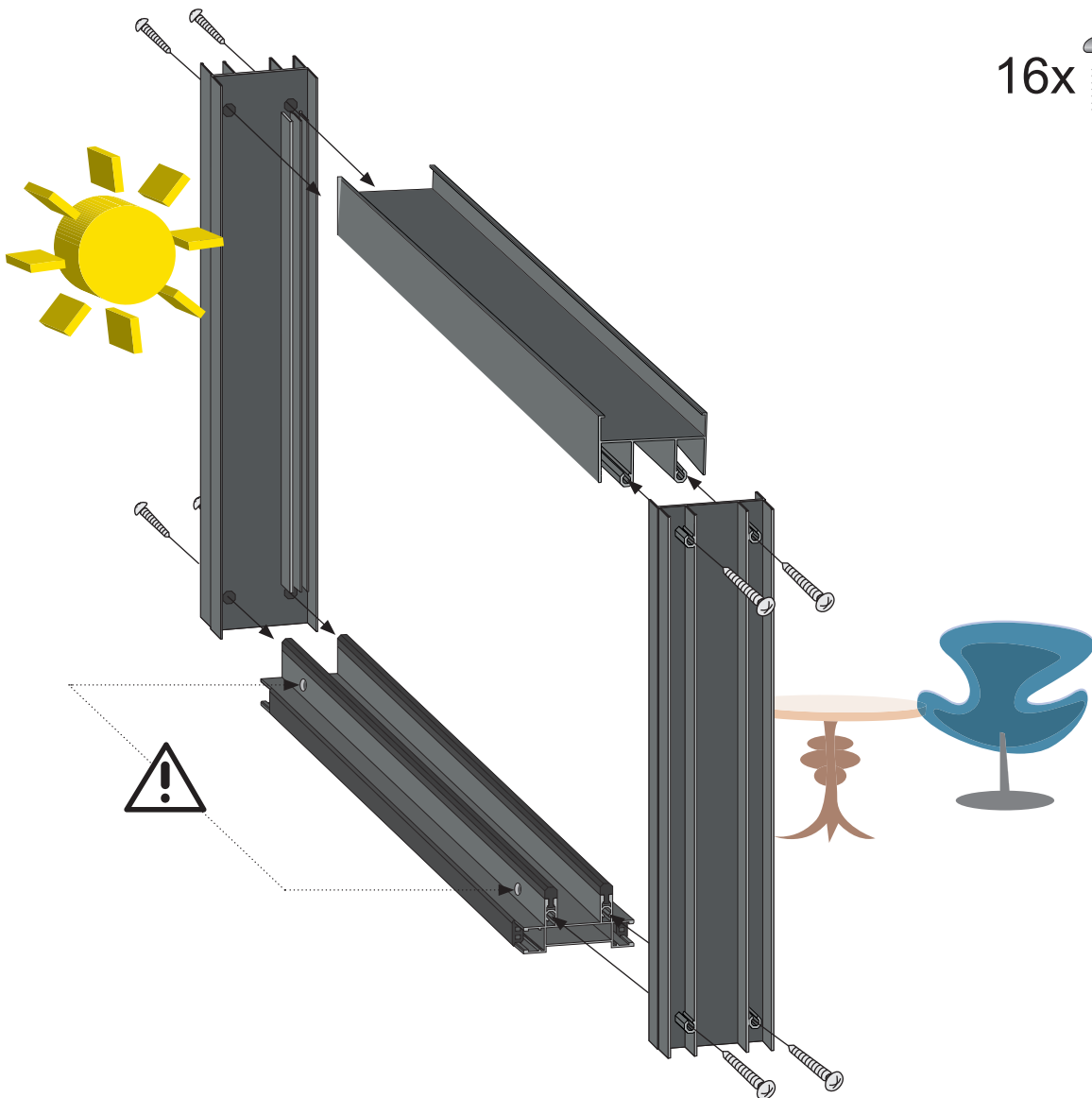

36 B

Ø4mm 4,2×50
6x

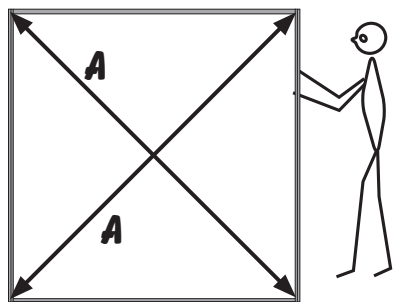
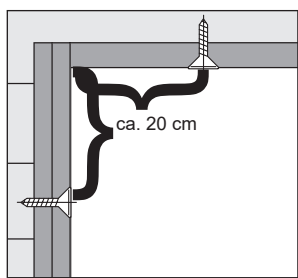

A=A

B 13

B 13

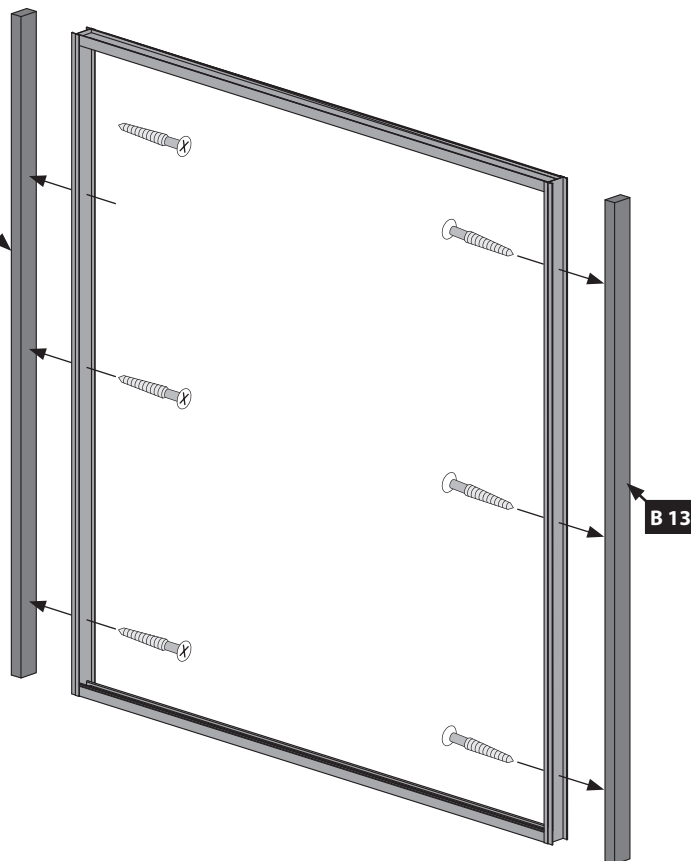

37 B

Ø4mm 4,2×50
4x

Ø4mm 4,2×50
4x

Ø7 mm 8×100
8x

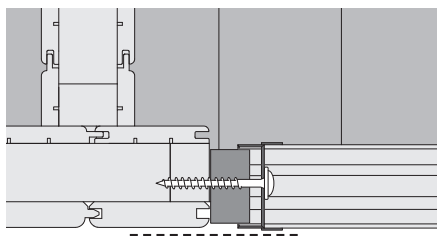
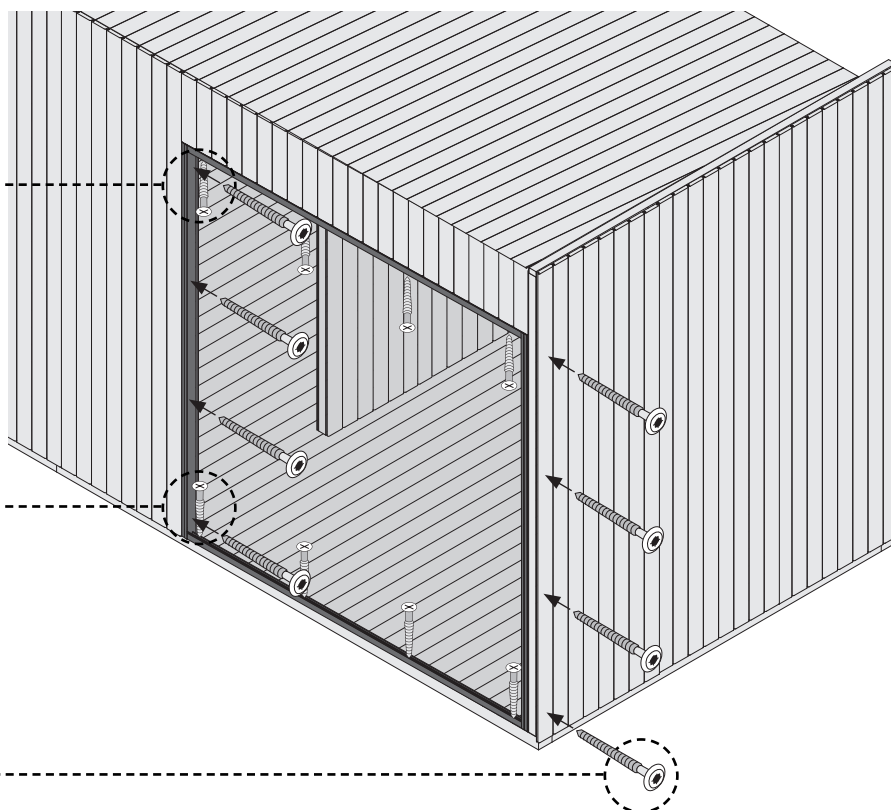

- | | | | |
|--|---------------|--|---------------------|
| | Bündig! | | Combacia! |
| | Flush! | | Stejný! |
| | Affleurement! | | V jednej rovine! |
| | Gelijk! | | Splakovanje! |
| | I flugt! | | Równa powierzchnia! |
| | Aras! | | |

38 B

32x

Ø3 mm 4x50

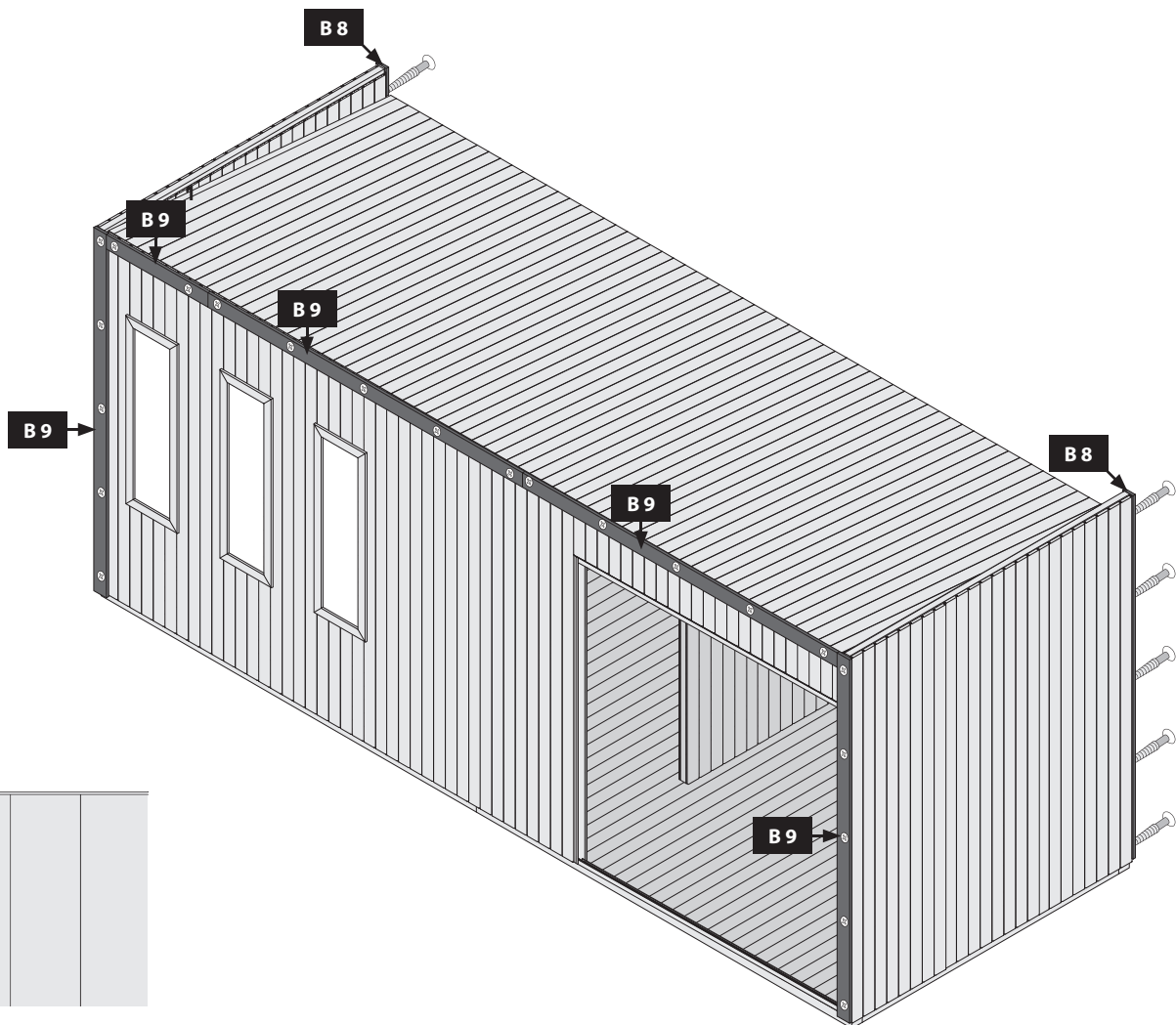
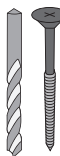

39 B

10x

Ø3 mm 4x50

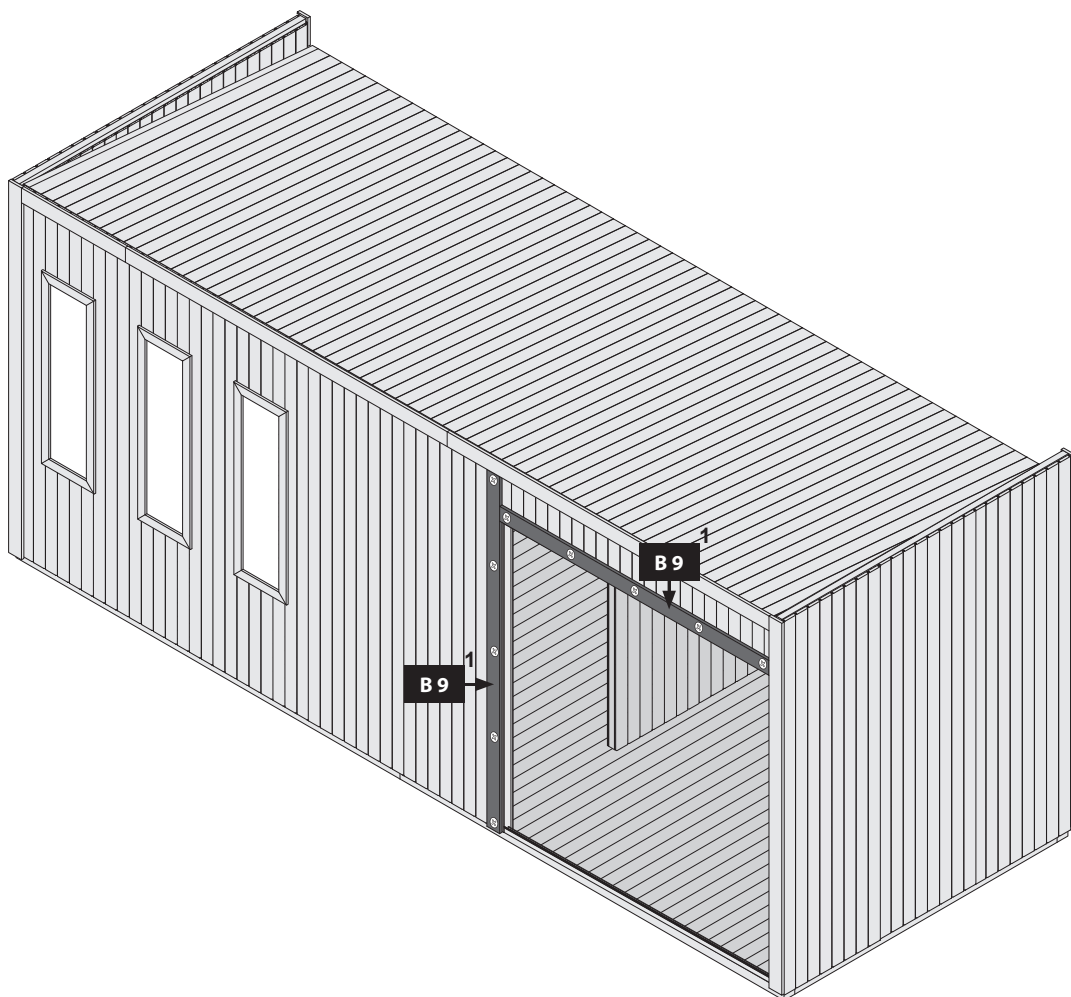
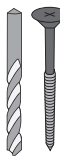

40 B

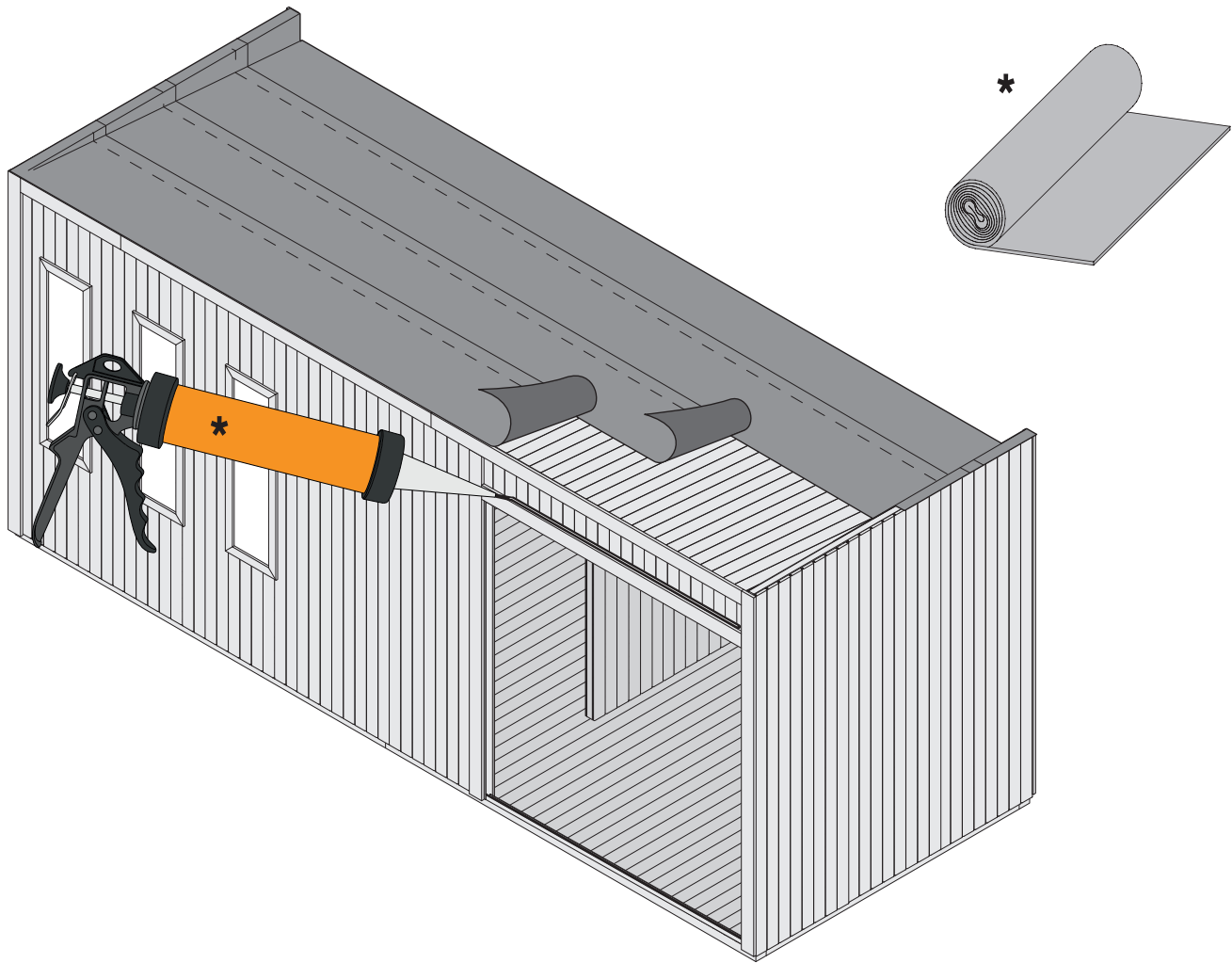

41 B

