

# Assembly, installation and maintenance manual

Montage-, Aufbau- und Wartungsanleitung • Assemblage, manuel de montage et d'entretien • Montaje, instalación y mantenimiento • Manuale di montaggio, installazione e manutenzione • Monterings- og vedlikeholdsmanual • Monterings-, installations- och underhållsmanual • Kokoamis-, asennus- ja huolto-ohje • Vejledning for montering og vedligehold • Handleiding voor montage, installatie en onderhoud • Manual de montagem, instalação e manutenção • Návod k montáži, instalaci a údržbě • Instrukcja montażu, instalacji i konserwacji • Surinkimo, montavimo ir priežiūros vadovas • Montāžas, uzstādīšanas un apkopes rokasgrāmata • Руководство по сборке и обслуживанию • Montaaži-, paigaldus- ja säilitamise juhend



## Element house **EL18-5645-2**

<p><b>Factory inspection by</b> • Werkskontrolle durch • Contrôle à partir de l'usine par • Inspector de fábrica • Collaudato da • Fabrikkontroll utført av • Fabriksbesiktigat av • Tehtaan tarkastaja • Fabriks Kontrol udført af • Fabrikscontrole door • Inspeção de fábrica, por: • Zkontrolováno ve výrobním závodě • Kontrola fabryczna do • Apžiūrą gamykloje atliko • Rūpnīcas pārbaudi veicis • Заводской контроль • Tehase kontroll teostatud:</p>	<p><b>Date</b> • Datum • Date • Fecha • Data • Dato • Datum • Päiväys • Dato • Datum • Data • Datum • Data • Datums • Data • Дата • Kuupäev:</p>
<p>.....</p>	<p><b>Pack number</b> • Pack Nr. • Packet n° • Bulto N° • Pacco N. • Serienr • Produktionsnummer • Pakettinro • Pakke nr. • Pak nr. • Número de embalagem • Číslo balení • Numer opakowania • Pakuotės numeris • Iepakojuma numurs • Упаковочный номер • Pakinumber:</p>



[www.palmako.ee/information-hub](http://www.palmako.ee/information-hub)

**English:** Before installing and using the product, please read the instructions and warranty terms at [www.palmako.ee/information-hub](http://www.palmako.ee/information-hub) to guarantee proper installation and long-lasting performance.

**Deutsch:** Wichtig! Bitte vor Aufbau und Nutzung des Produkts unbedingt die detaillierte Montageanleitung sowie die Garantiebedingungen unter [www.palmako.ee/information-hub](http://www.palmako.ee/information-hub) lesen, um eine fachgerechte Montage und eine lange Funktionssicherheit zu gewährleisten.

**Français:** Avant d'installer et d'utiliser le produit, veuillez lire les instructions et les conditions de garantie sur [www.palmako.ee/information-hub](http://www.palmako.ee/information-hub) afin de garantir une installation correcte et la longévité du produit.

**Español:** Antes de instalar y utilizar el producto, lea las instrucciones y las condiciones de garantía en [www.palmako.ee/information-hub](http://www.palmako.ee/information-hub) para asegurar una instalación correcta y una larga vida útil del producto.

**Italiano:** Prima di installare e utilizzare il prodotto, leggere le istruzioni e le condizioni di garanzia su [www.palmako.ee/information-hub](http://www.palmako.ee/information-hub) per garantire una corretta installazione e prestazioni durature.

**Norsk:** Før montering og bruk av produktet, vennligst les monteringsanvisningene og garantivilkårene på [www.palmako.ee/information-hub](http://www.palmako.ee/information-hub) for å sikre korrekt montering og fremtidig holdbarhet.

**Svenska:** Innan du installerar och använder produkten, vänligen läs instruktionerna och garantivillkoren på [www.palmako.ee/information-hub](http://www.palmako.ee/information-hub) för att säkerställa korrekt installation och produktens långvariga hållbarhet

**Suomi:** Ennen tuotteen asentamista ja käyttämistä, lue ohjeet ja takuehdot osoitteessa [www.palmako.ee/information-hub](http://www.palmako.ee/information-hub) varmistaaksesi oikean asennuksen ja pitkäkestoisen toiminnan.

**Русский:** Перед установкой и использованием изделия ознакомьтесь с инструкцией и условиями гарантии на сайте [www.palmako.ee/information-hub](http://www.palmako.ee/information-hub), чтобы гарантировать правильную установку и долговечность изделия.

**Eesti:** Enne toote paigaldamist ja kasutuselevõttu lugege palun juhiseid ja garantiitingimusi aadressil [www.palmako.ee/information-hub](http://www.palmako.ee/information-hub), et tagada nõuetekohane paigaldus ja toote pikk eluiga.

**Dansk (Oversat af AI):** Læs venligst instruktionerne og garantibetingelserne på [www.palmako.ee/information-hub](http://www.palmako.ee/information-hub), før du installerer og bruger produktet, for at garantere korrekt installation og langvarig ydeevne.

**Dutch (Vertaald door AI):** Lees vóór de installatie en het gebruik van het product de instructies en garantievoorwaarden op [www.palmako.ee/information-hub](http://www.palmako.ee/information-hub) om een correcte installatie en langdurige werking te garanderen

**Português (Traduzido por IA):** Antes de instalar e utilizar o produto, leia as instruções e os termos de garantia em [www.palmako.ee/information-hub](http://www.palmako.ee/information-hub) para garantir uma instalação adequada e um desempenho duradouro.

**Čeština (Přeloženo umělou inteligencí):** Před instalací a použitím produktu si prosím přečtěte pokyny a záruční podmínky na [www.palmako.ee/information-hub](http://www.palmako.ee/information-hub), abyste zaručili správnou instalaci a dlouhodobý výkon.

**Polski (Przetłumaczone przez AI):** Przed zainstalowaniem i użyciem produktu należy przeczytać instrukcję oraz warunki gwarancji dostępne na stronie [www.palmako.ee/information-hub](http://www.palmako.ee/information-hub), co pozwoli zagwarantować prawidłową instalację i długotrwałą wydajność.

**Latviešu (Mākslīgā intelekta tulkojums):** Pirms produkta uzstādīšanas un lietošanas, lūdzu, izlasiet instrukcijas un garantijas noteikumus vietnē [www.palmako.ee/information-hub](http://www.palmako.ee/information-hub), lai garantētu pareizu uzstādīšanu un ilgstošu darbību.

**Lietuviškai (Išvertė DI):** Prieš montuodami ir naudodami gaminį, perskaitykite instrukcijas ir garantijos sąlygas adresu [www.palmako.ee/information-hub](http://www.palmako.ee/information-hub), kad užtikrintumėte tinkamą montavimą ir ilgalaikį veikimą.

562

448

398





19.4 m<sup>2</sup>

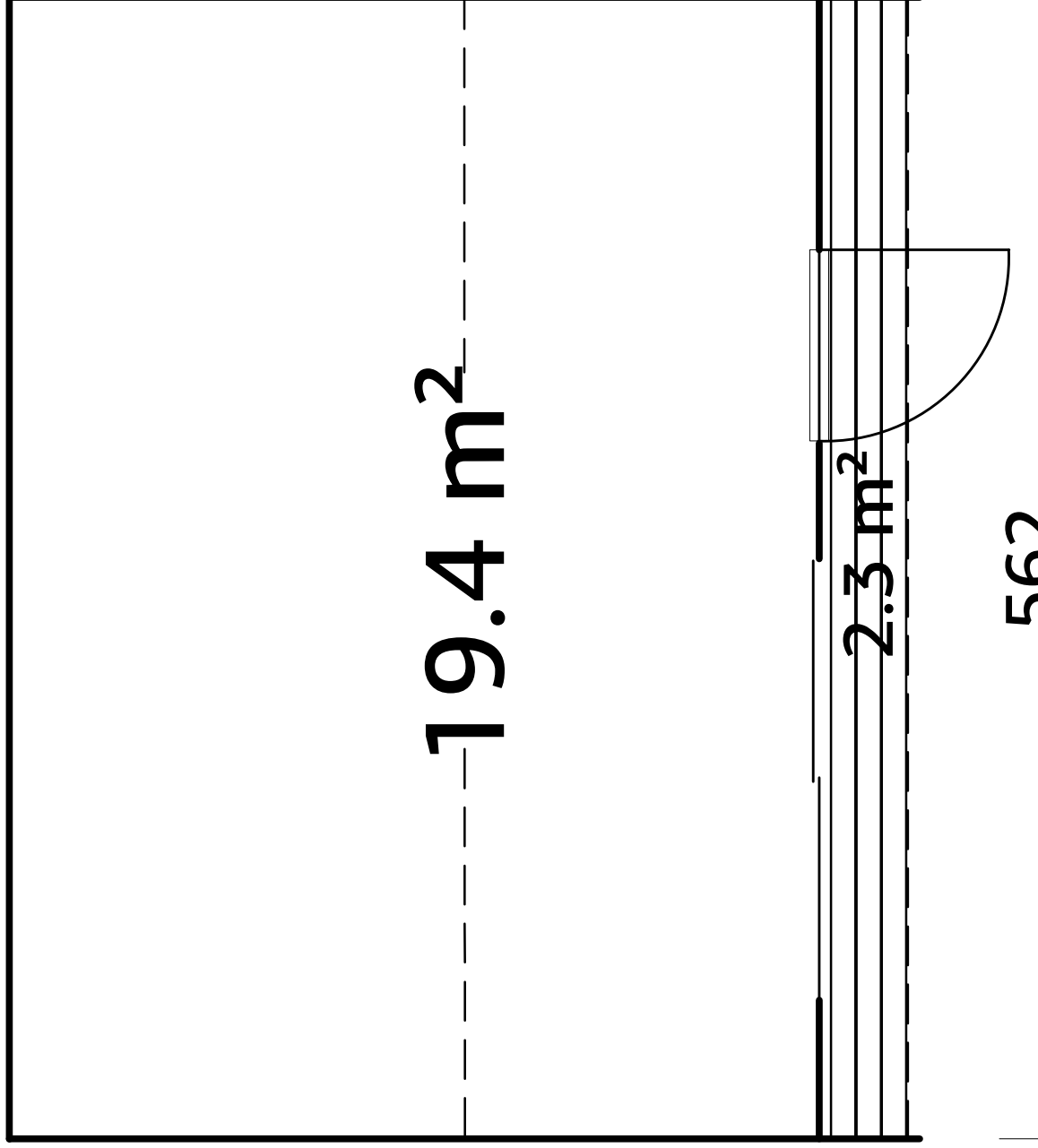

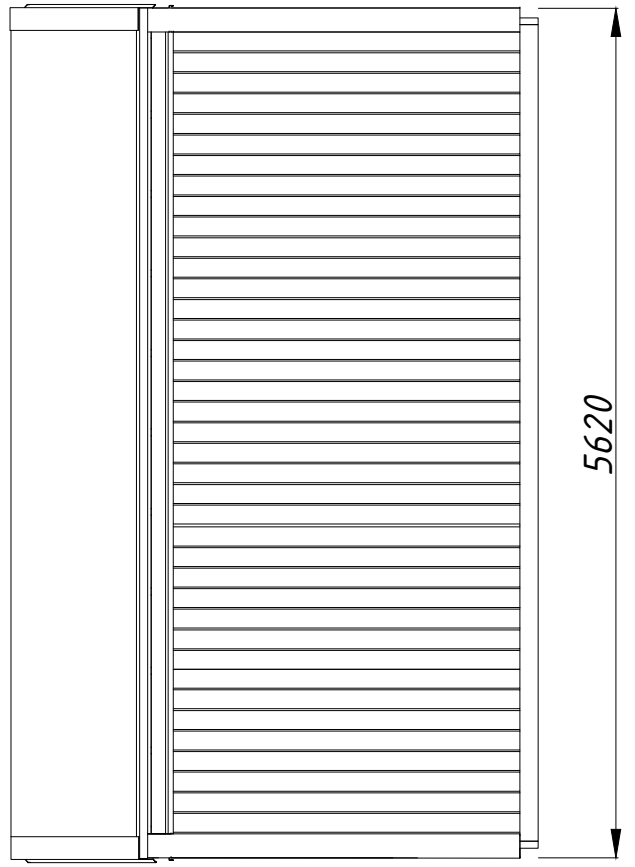
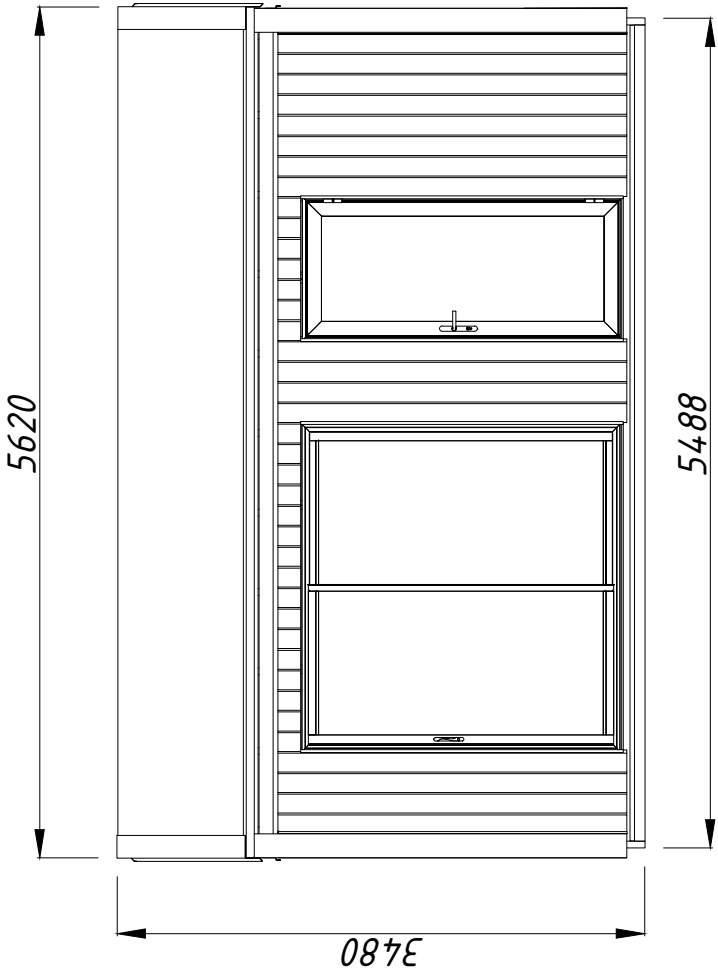
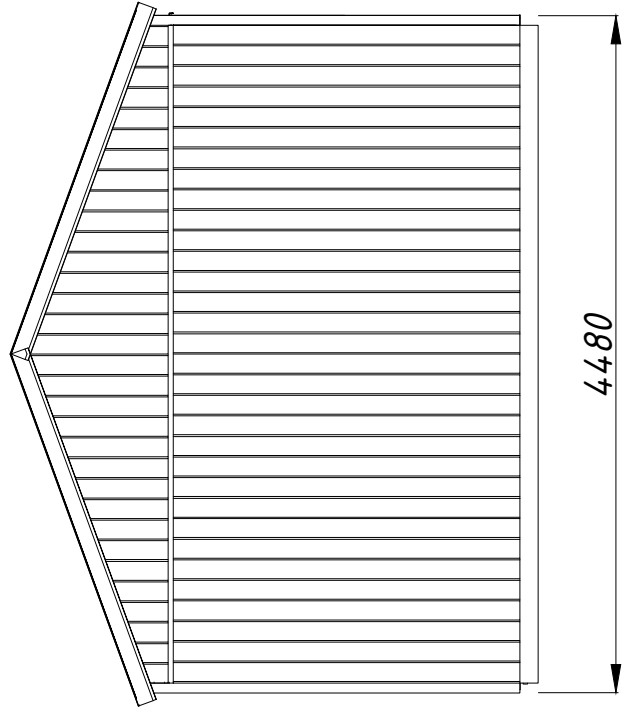
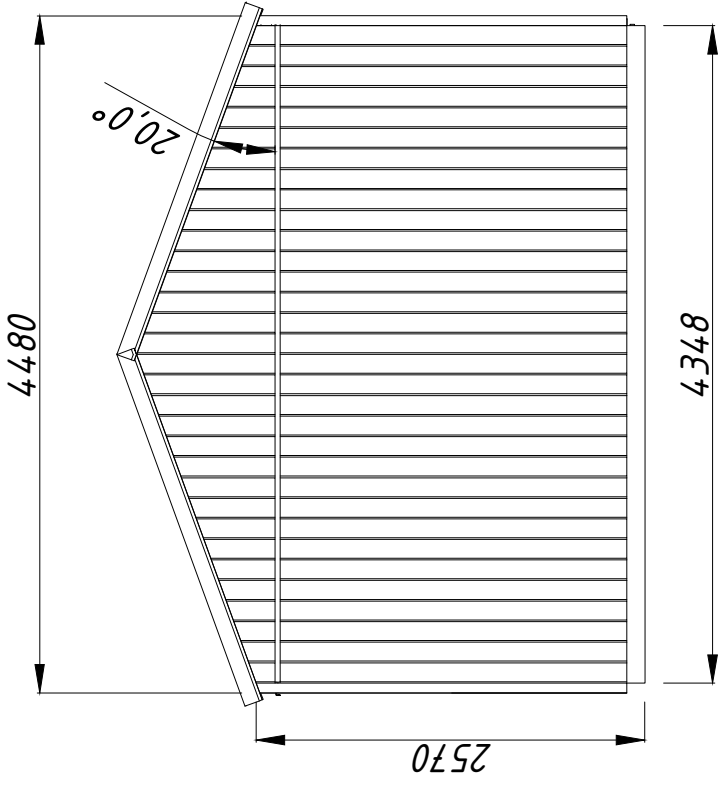

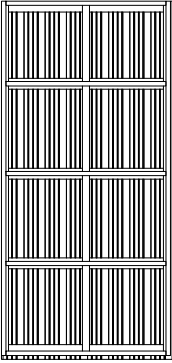
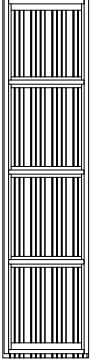
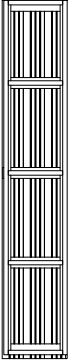

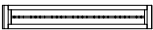

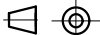



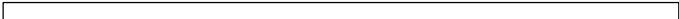









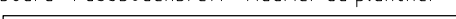

2.3 m<sup>2</sup>

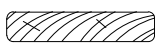
562









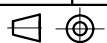





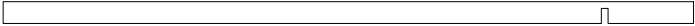





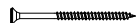

Pos	SPECIFICATION-STÜCKLISTE-NOMENCLATURE-ELEMENTI-ESPECIFICACIÓN EL18-5634-1-1	Pcs	Profile (mm)	Length (mm)
EL1		10	1087X160	2280
EL2		1	543X160	2280
EL3		2	407X160	2280
EL4		1	150X160	2175
EL5		1	150X160	950
EL-Door		1	137X160	2280
	Object name EL18-5634-1-1			Page 1/1

Pos	SPECIFICATION-STÜCKLISTE-NOMENCLATURE-ELEMENTI-ESPECIFICACIÓN EL18-5645-1-2	Pcs	Profile (mm)	Length (mm)
AR1	Foundation- Fundament- Fondation- Fondazione- Vigas de cimentación 	4	45x70	2699
AR2	Foundation- Fundament- Fondation- Fondazione- Vigas de cimentación 	24	45x145	2654
AR3	Foundation- Fundament- Fondation- Fondazione- Vigas de cimentación 	2	45x145	4348
AR4	Foundation- Fundament- Fondation- Fondazione- Vigas de cimentación 	12	45x70	406
AR5	Foundation- Fundament- Fondation- Fondazione- Vigas de cimentación 	2	45x145	3852
BM1	Beam- Balken- Poutre- Trave- Viga 	1	140x44	2717
BM2	Beam- Balken- Poutre- Trave- Viga 	1	140x44	3381
Sla1	Slat- Leiste- Baguette- Listello- Listón 	2	45x45	2380
Sla2	Slat- Leiste- Baguette- Listello- Listón 	2	45x45	2918
Sla3	Slat- Leiste- Baguette- Listello- Listón 	1	95x44	2676
Sla4	Slat- Leiste- Baguette- Listello- Listón 	1	95x44	2812
Sla5	Slat- Leiste- Baguette- Listello- Listón 	2	95x44	4253
FB2-1	Floor board- Fussbodenbrett- Madrier du plancher - Tavola pavimento- Tabla de suelo 	60+1	89x19	3656
TB2-1	Terrace board- Terrassenbrett- Madrier de terrasse- Tavola terrazzo- Tabla de terraza 	5	120x28	3783
TB2-2	Terrace board- Terrassenbrett- Madrier de terrasse- Tavola terrazzo- Tabla de terraza 	5	120x28	1615
TB1-1	Ceiling board- Dachbodenbrett- Madrier du Grenier- Tavola soffitta- Tabla de techo 	9	95x19	3174
TB1-2	Ceiling board- Dachbodenbrett- Madrier du Grenier- Tavola soffitta- Tabla de techo 	9	95x19	2124
FB5-3	Ceiling board- Dachbodenbrett- Madrier du Grenier- Tavola soffitta- Tabla de techo 	10	95x19	2162
WG6-1	Water gutter- Wasserleiste- Rejet d'eau- Protección de lluvia- Protezione dalla pioggia- QP81x58x...HA 	4		2400
WG6-2	Water gutter- Wasserleiste- Rejet d'eau- Protección de lluvia- Protezione dalla pioggia- QP81x58x...HA 	2		2850
UL1	Ukse laudis 	4	70x12	2250
UL2	Ukse laudis 	1	70x12	950
UL3	Ukse laudis 	1	70x12	2165
UL4	Ukse laudis 	1	19x95	2165
UL5	Ukse laudis 	1	19x95	945



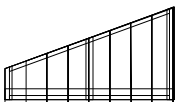
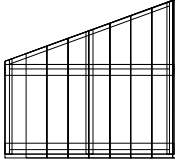
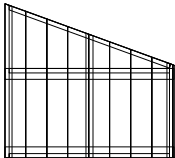

Pos	SPECIFICATION-STÜCKLISTE-NOMENCLATURE-ELEMENTI-ESPECIFICACIÓN EL18-5645-2-3	Pcs	Profile (mm)	Length (mm)
Pst1	Post- Pfosten- Poteau- Montante- Poste 	4	65x160	2550
RoR1	Rafter- Sparre- Chevron- Trave- Cabrio 	11	140x44	703
RoR2	Rafter- Sparre- Chevron- Trave- Cabrio 	22	140x44	2379
RoR3	Rafter- Sparre- Chevron- Trave- Cabrio 	11	140x44	4442
RB2-1	Roof board- Dachbrett- Madrier du toit- Tavola tetto- Tabla de tejado 	56	89x19	3334
RB2-2	Roof board- Dachbrett- Madrier du toit- Tavola tetto- Tabla de tejado 	56	89x19	2283
WG12-1	Water gutter- Wasserleiste- Rejet d'eau- Protección de lluvia- Protezione dalla pioggia- QP124x124x...HA 	4		2440
WG11-1	Water gutter- Wasserleiste- Rejet d'eau- Protección de lluvia- Protezione dalla pioggia- QP189x125x...HA 	4		2900
QNA2 2x50Zn	Nail- Nagel- Clou- Chiodo- Clavo- 2.5x50mm 	740	FB2-1	
QNA3 x70Zn	Nail- Nagel- Clou- Chiodo- Clavo- 3x70mm 	700	RB2-1 RB2-2	
QKRPP4 5x60Zn	Screw- Schraube- Vis- Vite- Tornillo- 4.5x60mm 	530	EL6, 7, 8 EL1+EL2+EL3	
QKRK K4_8 x28MU	Screw- Schraube- Vis- Vite- Tornillo- 4.8x28mm MU 	100		
QKRPP5 x80RVTX	Screw- Schraube- Vis- Vite- Tornillo- 5x80mm RVTX 	275	EL6, 7, 8 EL1, EL2, EL3+ AR1, 2... EL1, EL2, EL3+ Sla3, 4, 5	
QKRPP6x 120RvTx	Screw- Schraube- Vis- Vite- Tornillo- 6x120mm RvTx 	32	RoR1, 2, 3 BM1, 2 Sla1, 2...	
QKRPP 6x160 ZnTX-1	Screw- Schraube- Vis- Vite- Tornillo- 6x160mm TX-1 	245	RoR1, 2, 3 AR1, 2, 3...	
QKRPP 8x240 kZnTX	Screw- Schraube- Vis- Vite- Tornillo- 8x240mm 	132	RoR1, 2, 3	
EL12		2	1087X160	622
EL13		2	1087X160	992
EL14		2	1087X160	992
EL15		2	1087X160	622

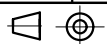

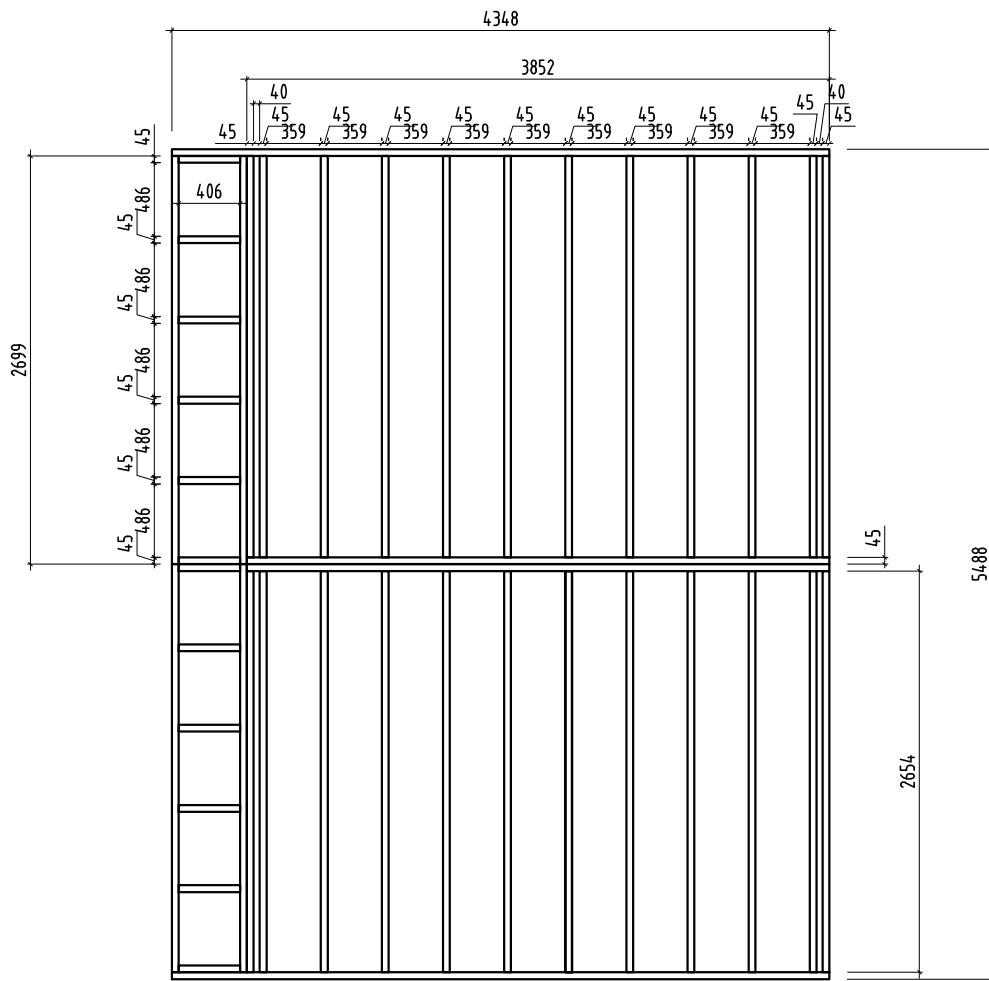

Foundation plan

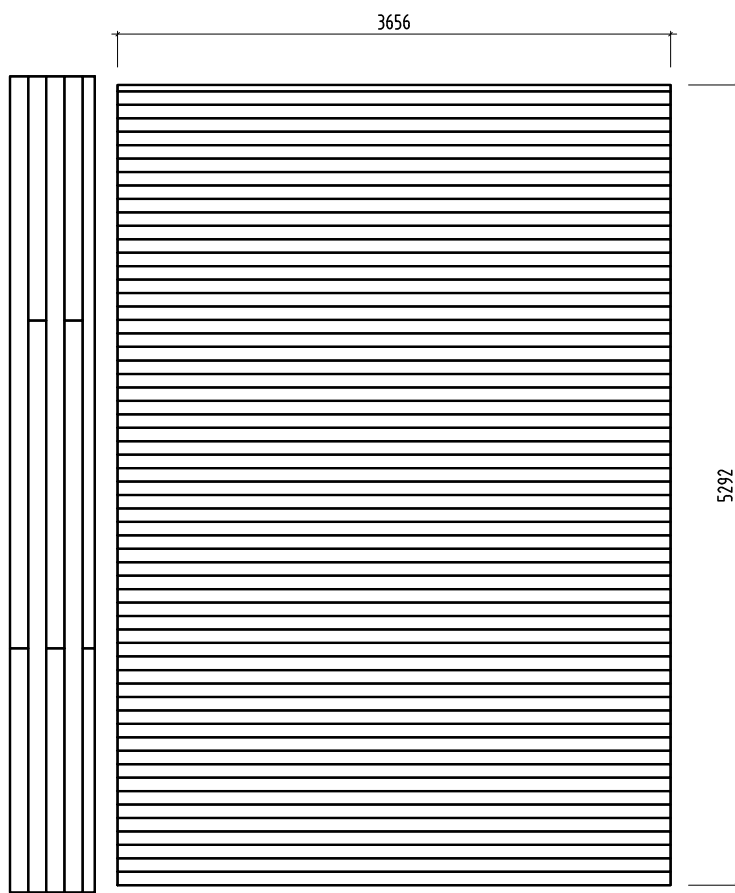

Floor and terrace plan

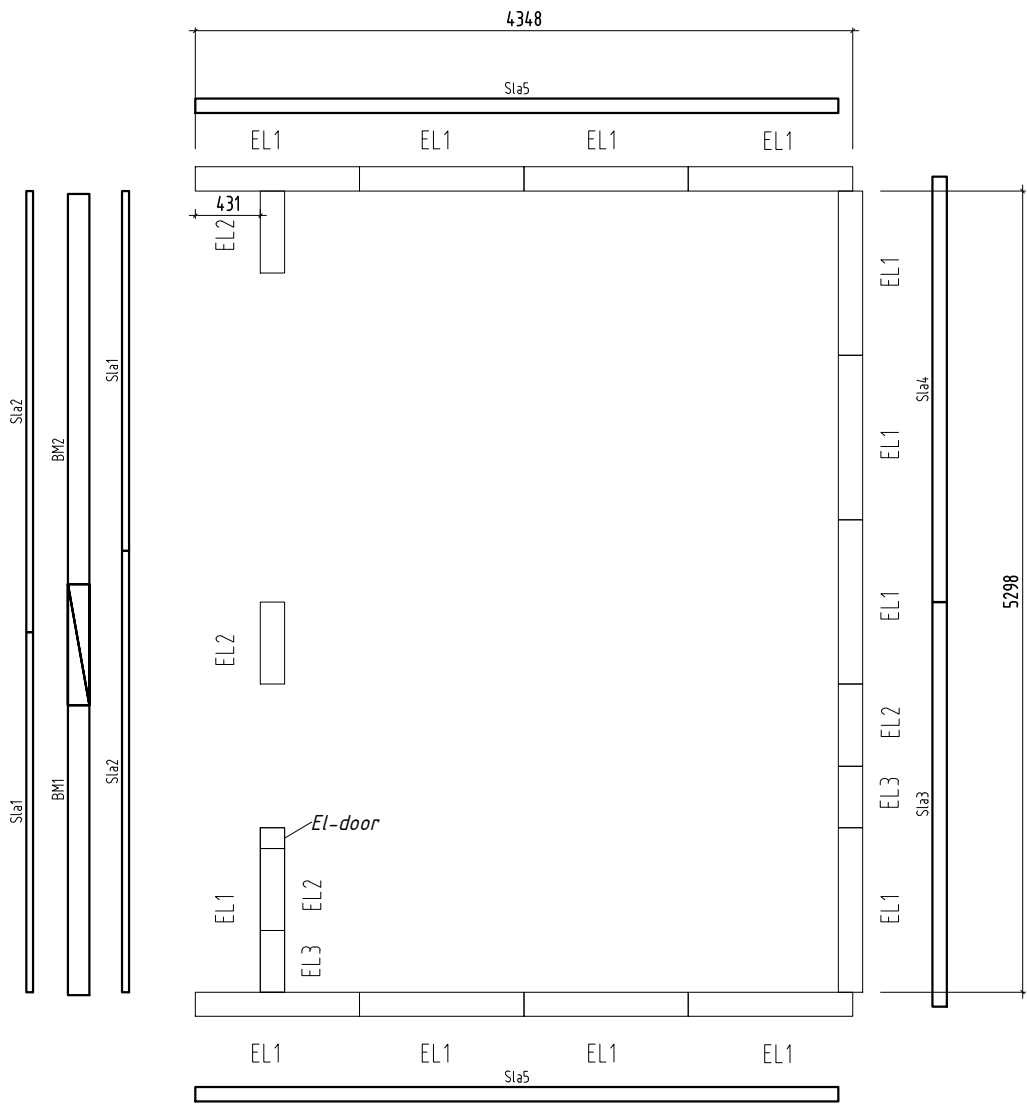

Wall panel plan

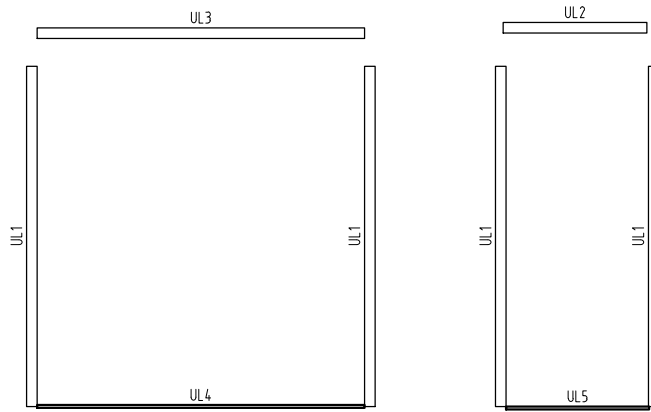

Door lath plan

NB!

1.

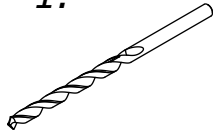

2.

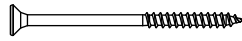

$\varnothing 1,5 \text{ mm}$	$\varnothing 3,0...4$
$\varnothing 2,0 \text{ mm}$	$\varnothing 4,5$
$\varnothing 3,0 \text{ mm}$	$\varnothing 5,0$

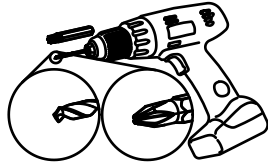
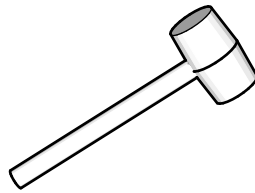
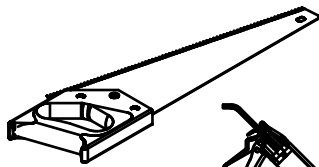
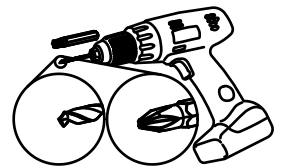
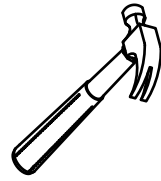
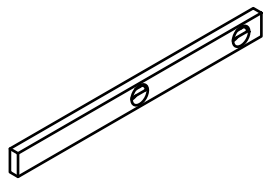
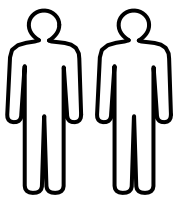
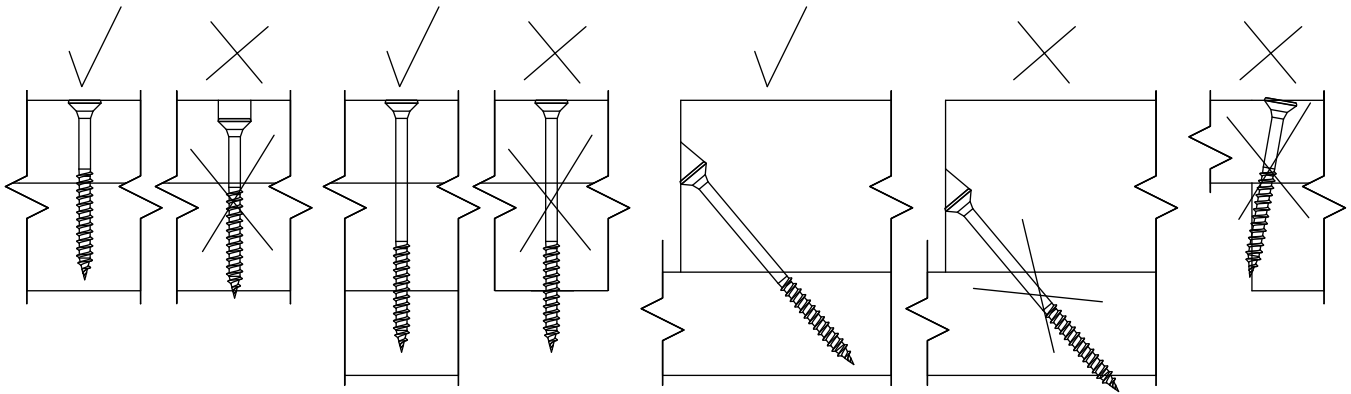

**\***

ENG	-	Not included
GER	-	Nicht enthalten
FR	-	Non inclus
ES	-	No incluso
IT	-	Non incluso
NO	-	Ikke inkludert
SWE	-	Ingår inte
FIN	-	Ei sisälly hintaan
DEN	-	Ikke inkluderet
NED	-	Niet inbegrepen
POR	-	Não incluído
CZ	-	Není zahrnuto
POL	-	Nie wliczone
LIT	-	Neįtraukta
LAT	-	Nav iekļauts
RUS	-	Не включено
EST	-	Ei sisaldu komplektis

**\*\***

ENG	-	Separate manual
GER	-	Separates Handbuch
FR	-	Manuel séparé
ES	-	Manual separado
IT	-	Manuale separato
NO	-	Separat manual
SWE	-	Separat manual
FIN	-	Erillinen käyttöohje
DEN	-	Separat manual
NED	-	Aparte handleiding
POR	-	Manual separado
CZ	-	Samostatný manuál
POL	-	Osobna instrukcja
LIT	-	Atskiras vadovas
LAT	-	Atsevišķa rokasgrāmata
RUS	-	Отдельное руководство
EST	-	Eraldi juhend

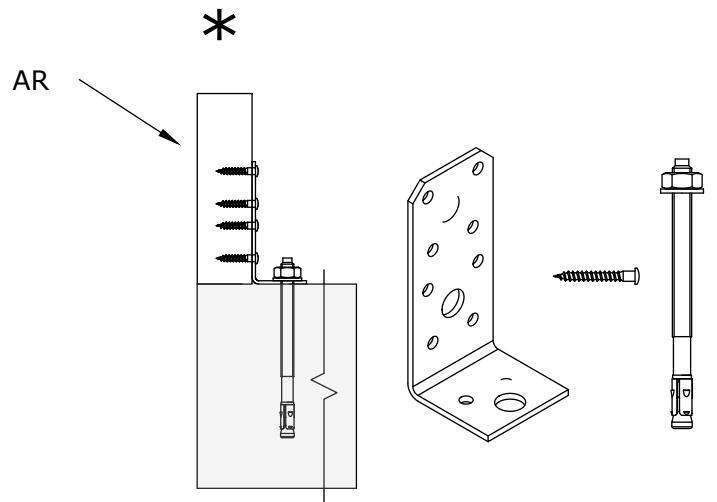
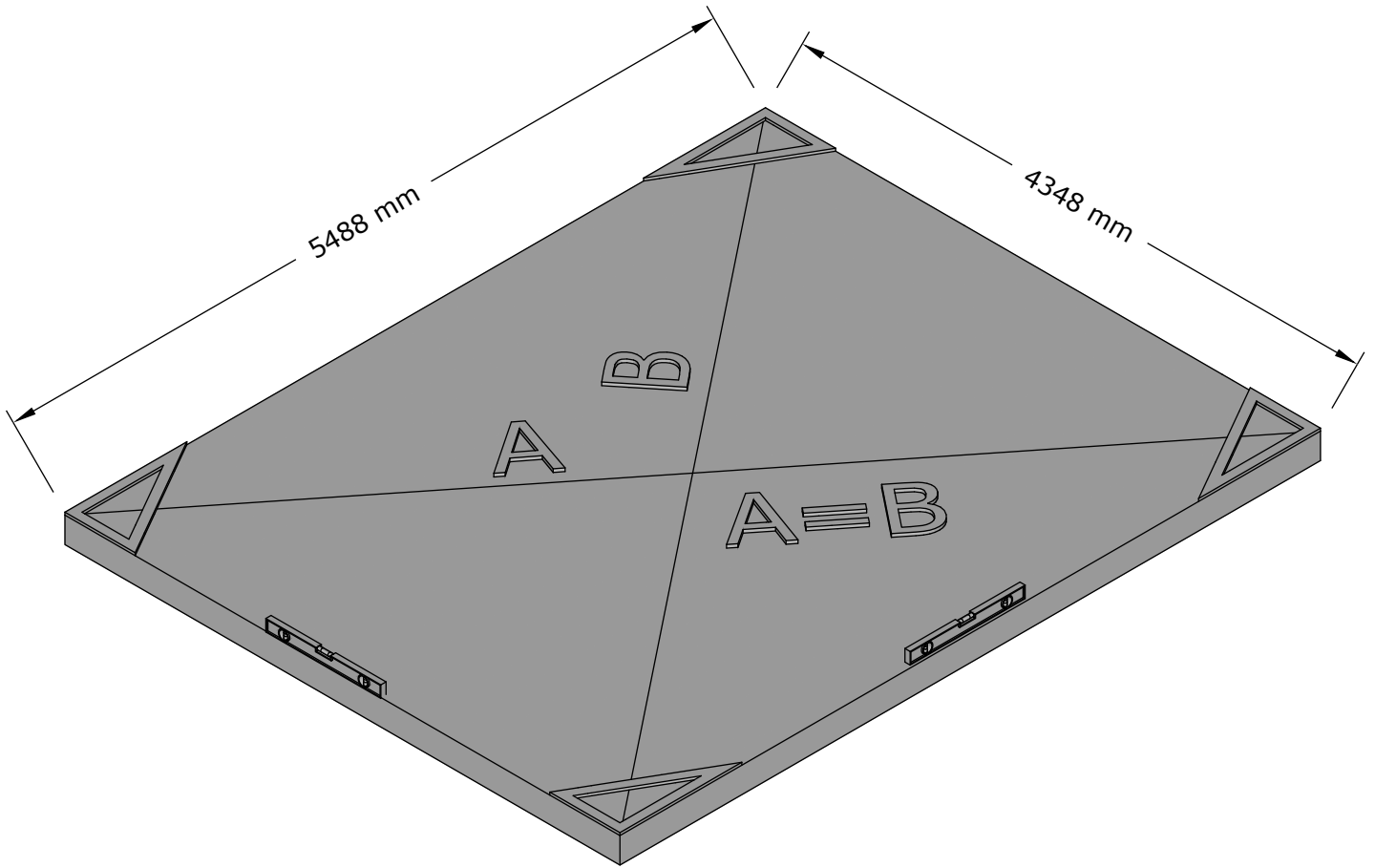
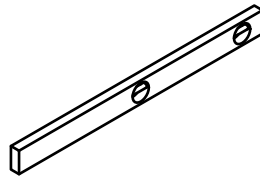

- AR1 x4
- AR2 x24
- AR3 x2
- AR4 x12
- AR5 x2

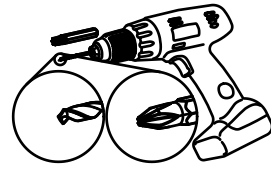
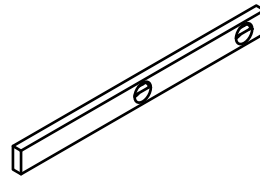

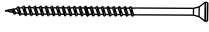
Ø5x80 x60 

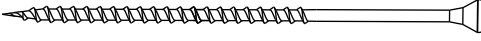
Ø6x160 x144 

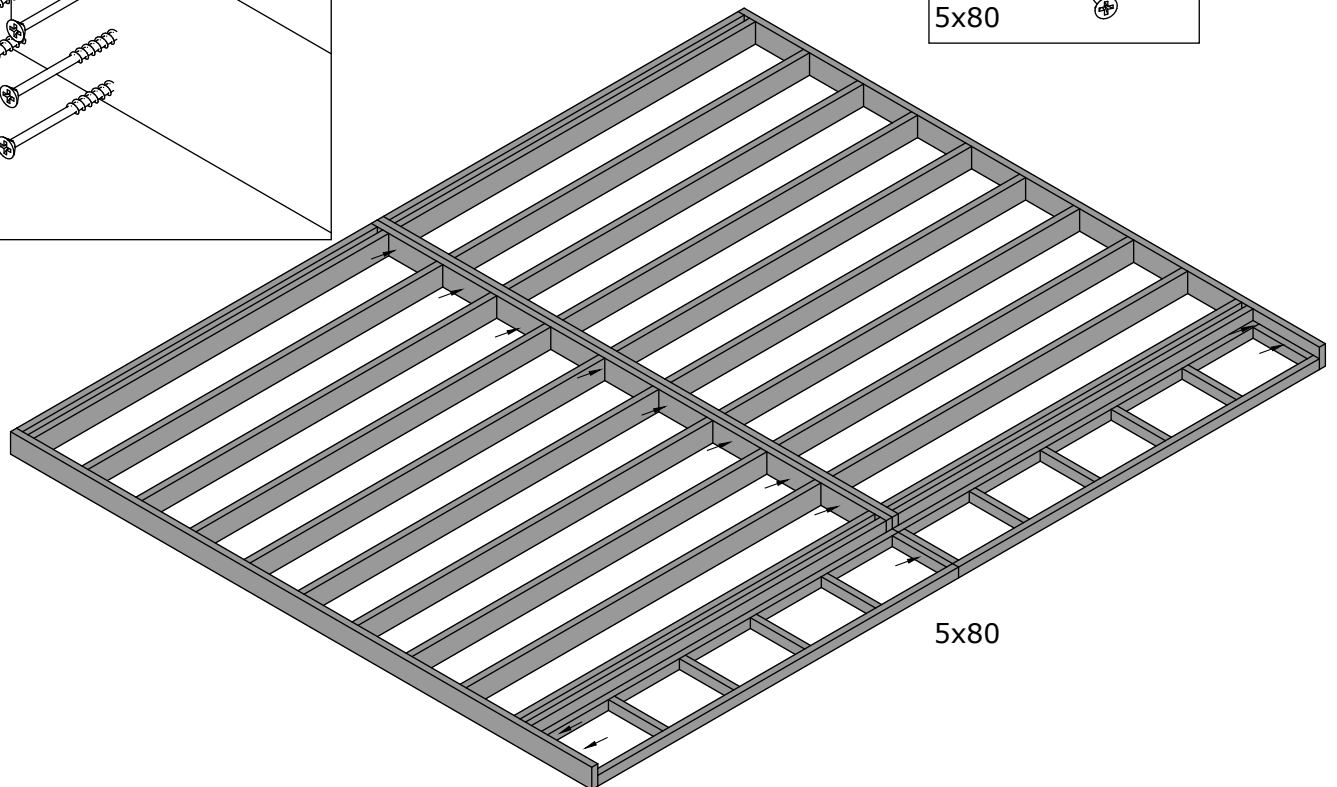
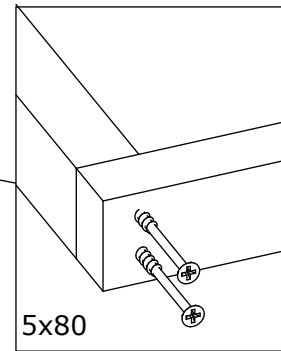
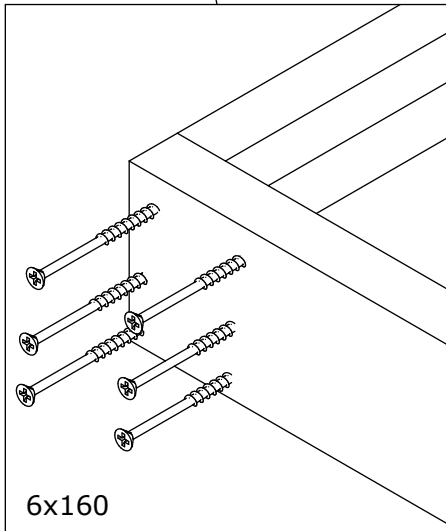
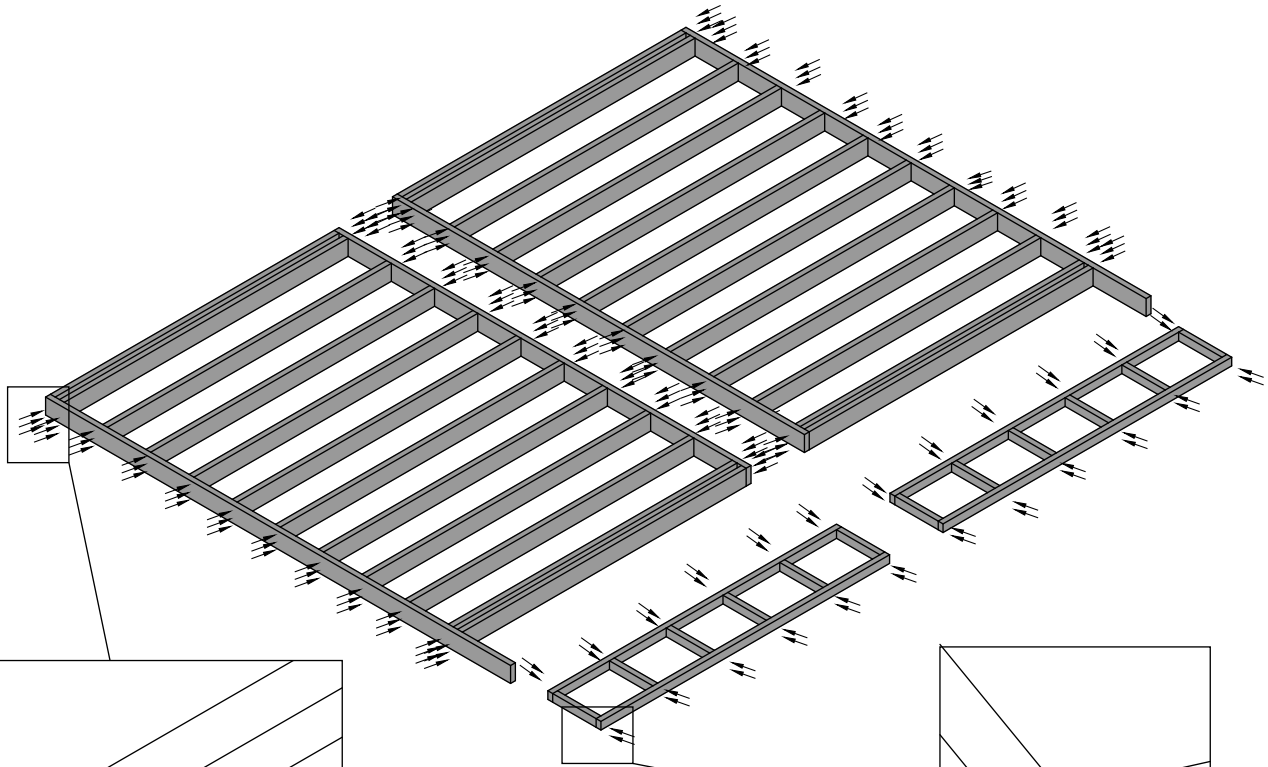



- E1 x12
- E2 x3
- E3 x1
- E4 x1
- E5 x1

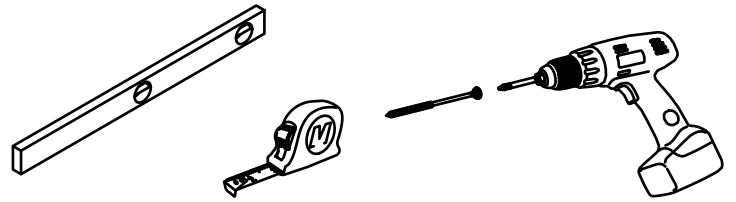

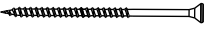
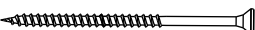
- Ø4,5x60 x72 
- Ø5x80 x54 

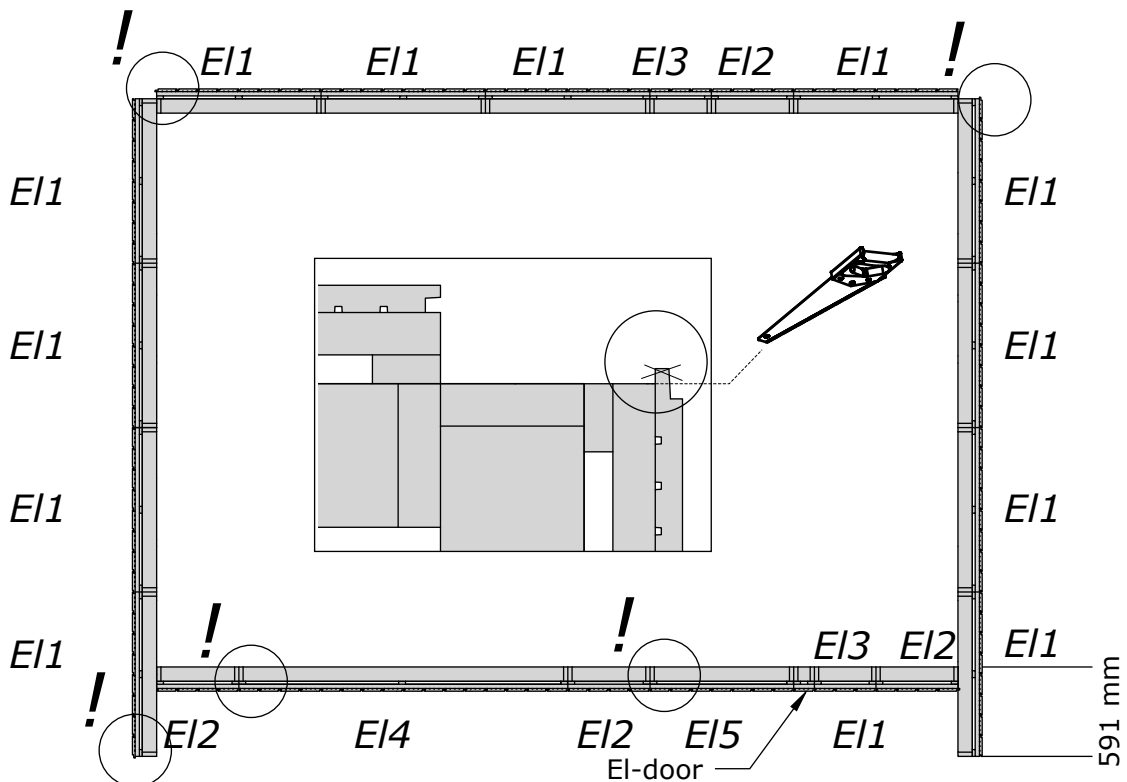
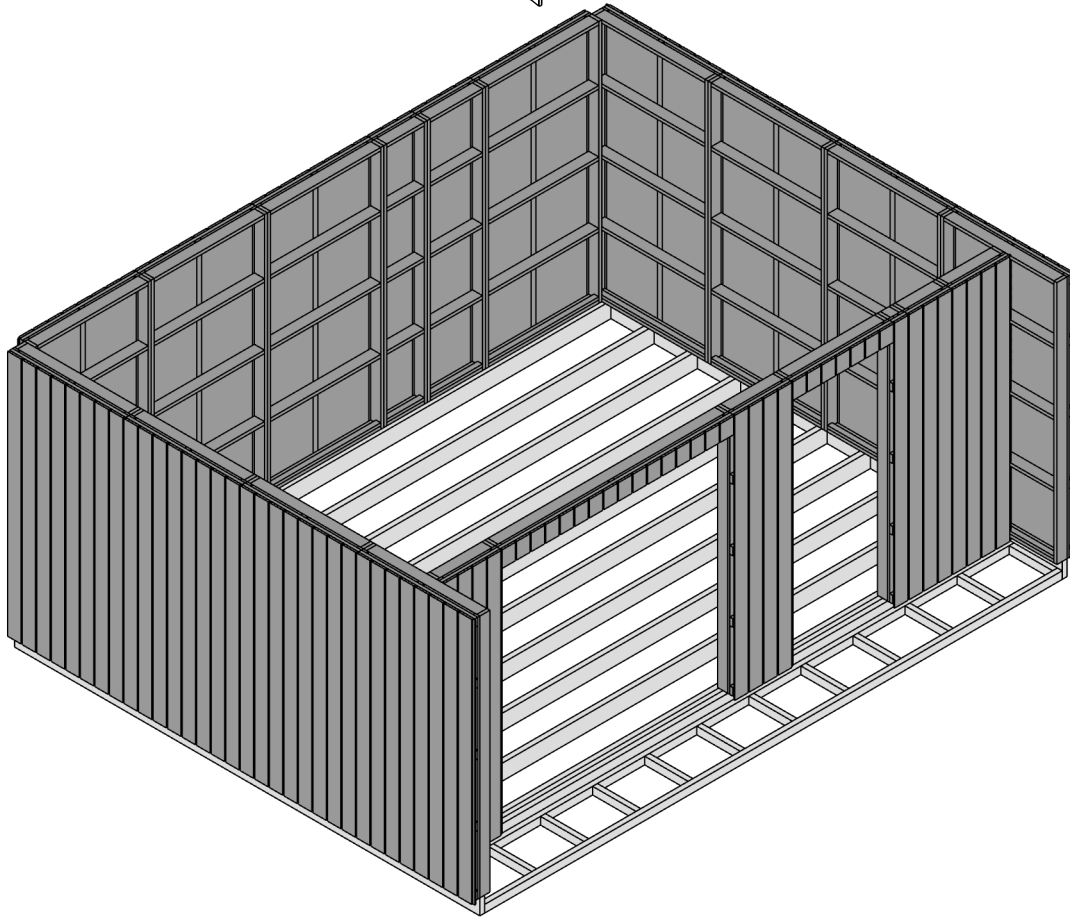

- E11 x12
- E12 x3
- E13 x1
- E14 x1
- E15 x1

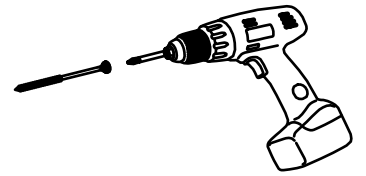
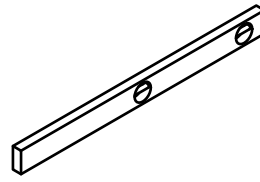

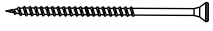
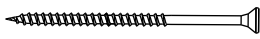
- Ø4,5x60 x72 
- Ø5x80 x54 

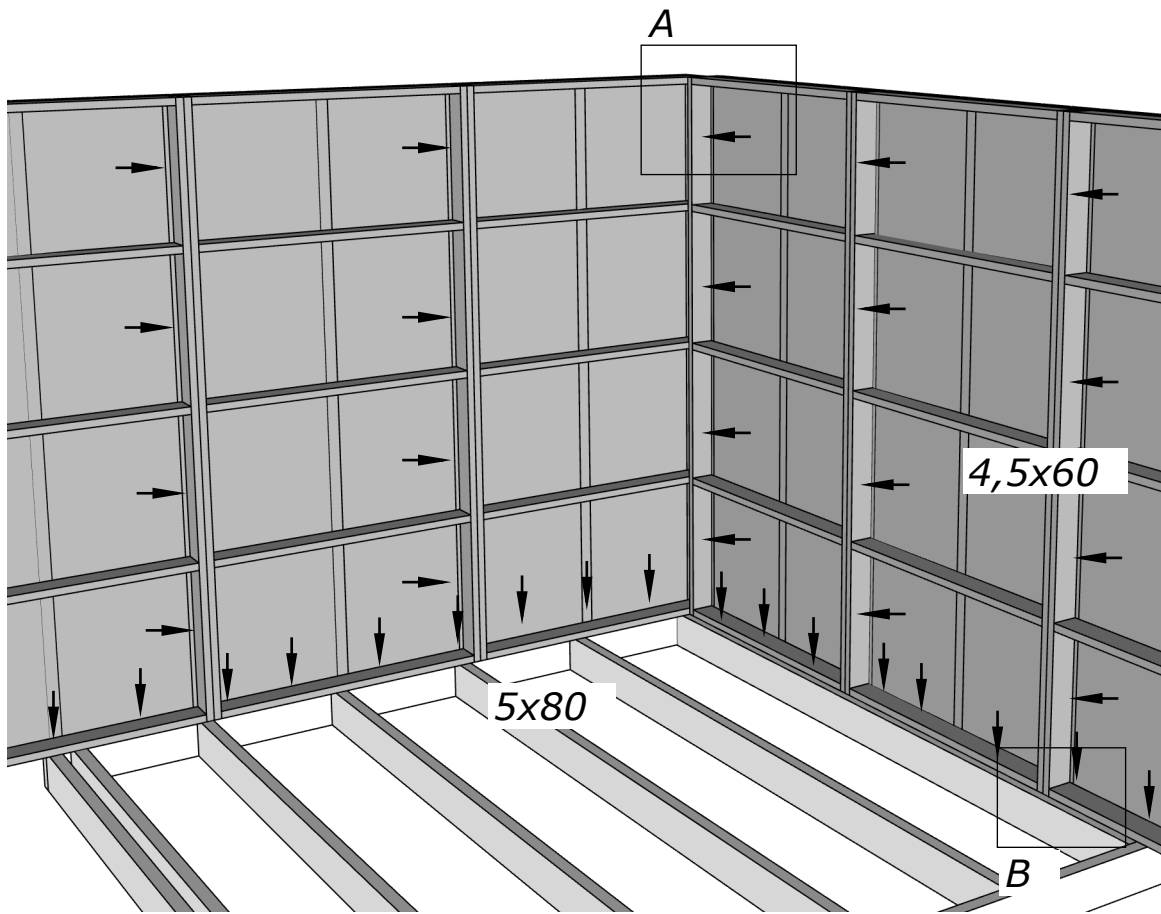

A

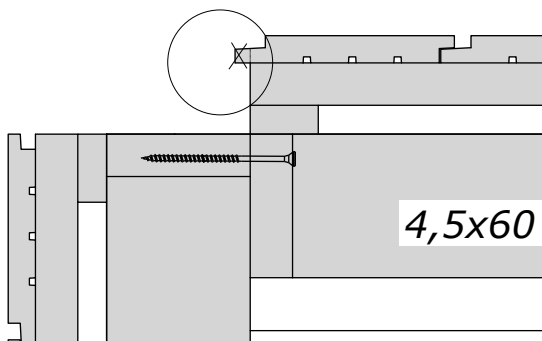

B

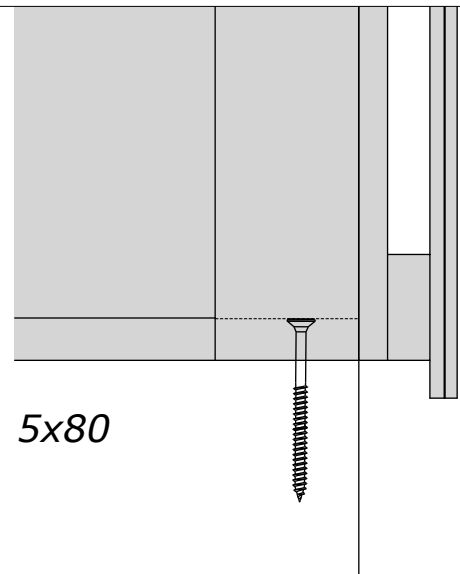

Sla3 x1  
Sla4 x1  
Sla5 x2

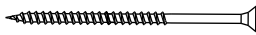
Ø5x80 x30 

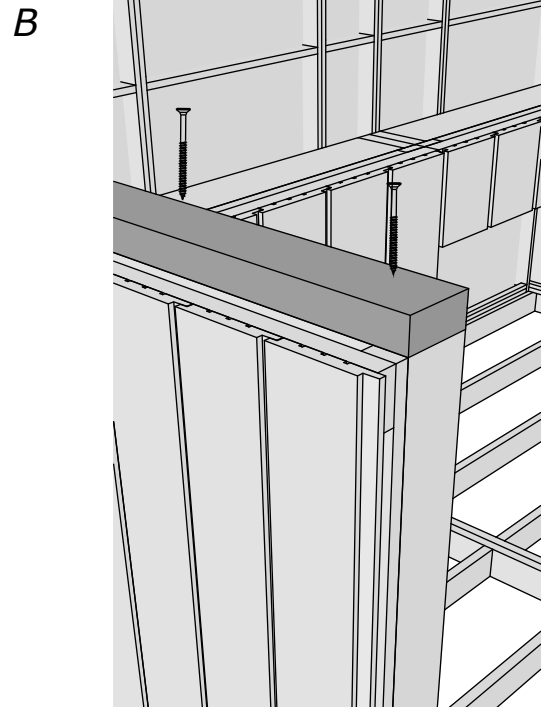
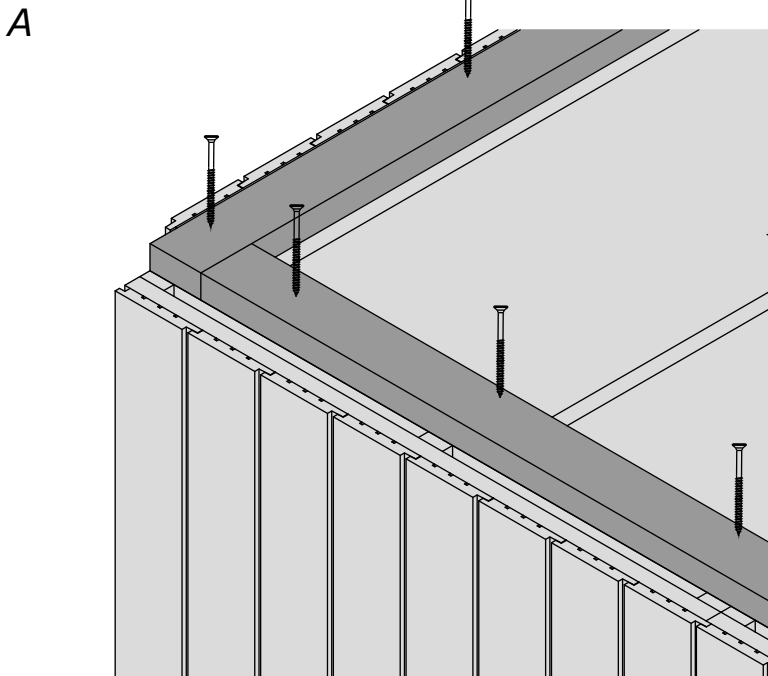
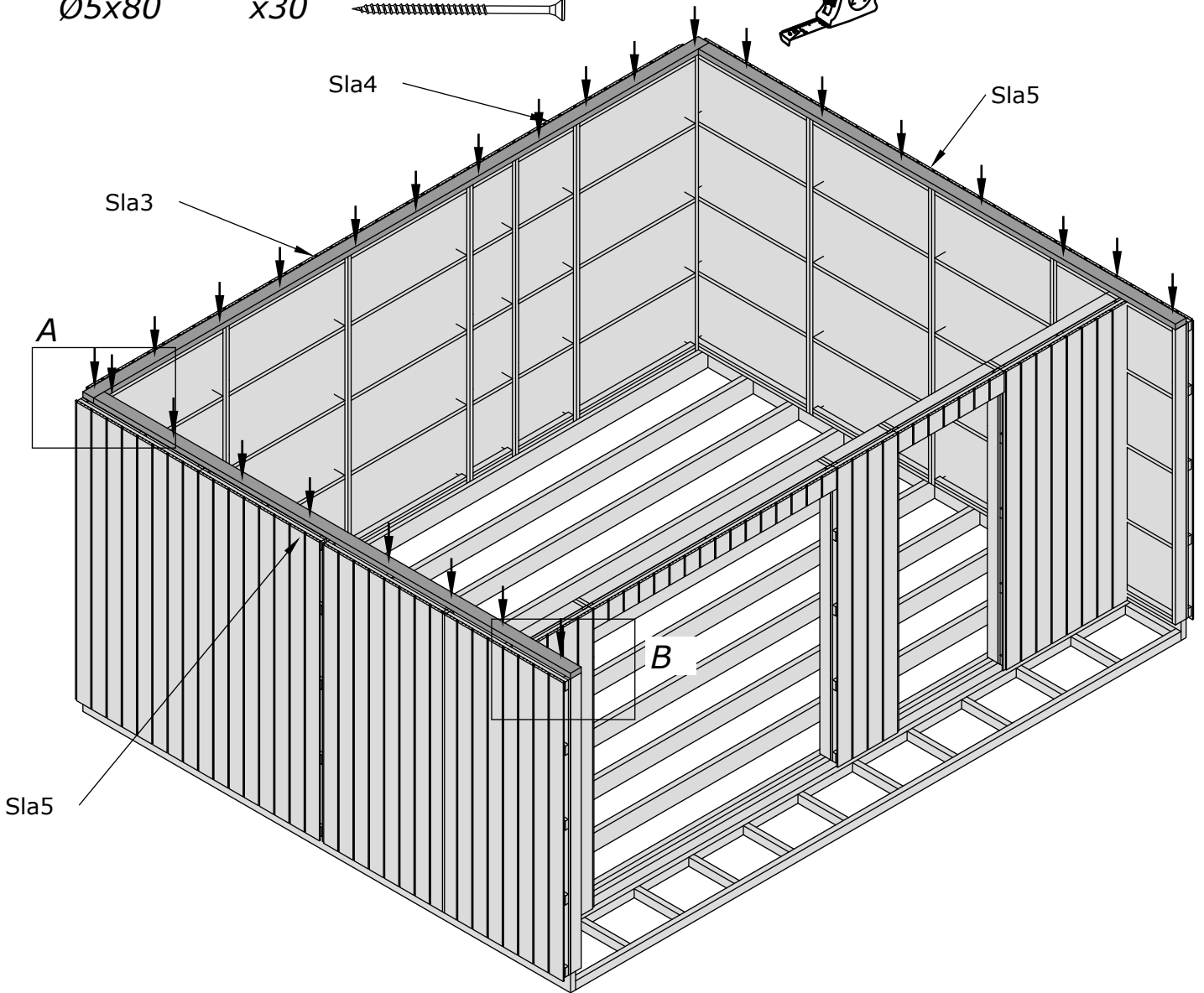
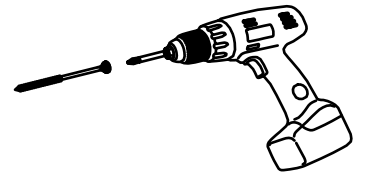
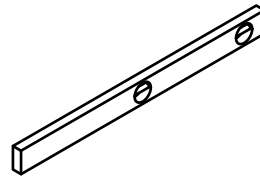

WG6-1 x4

WG6-2 x2

Ø4,8x28

x24

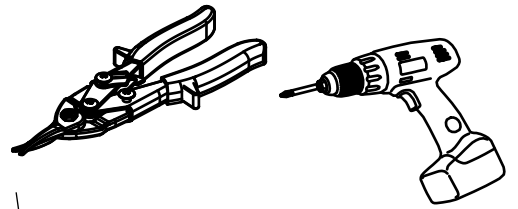

WG6-1

WG6-2

WG6-1

WG6-2

WG6-1

WG6-1

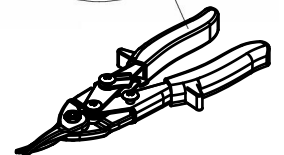
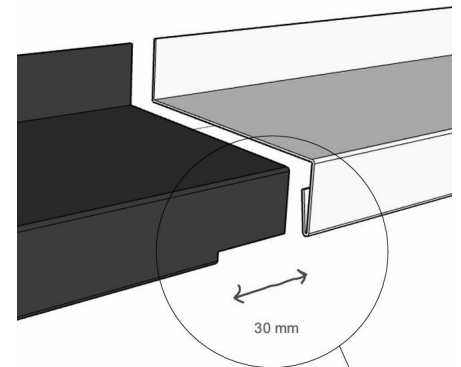
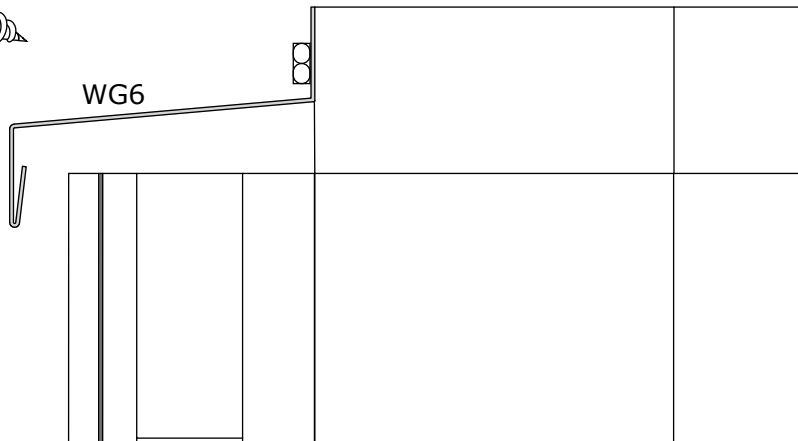
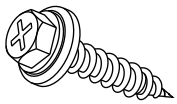
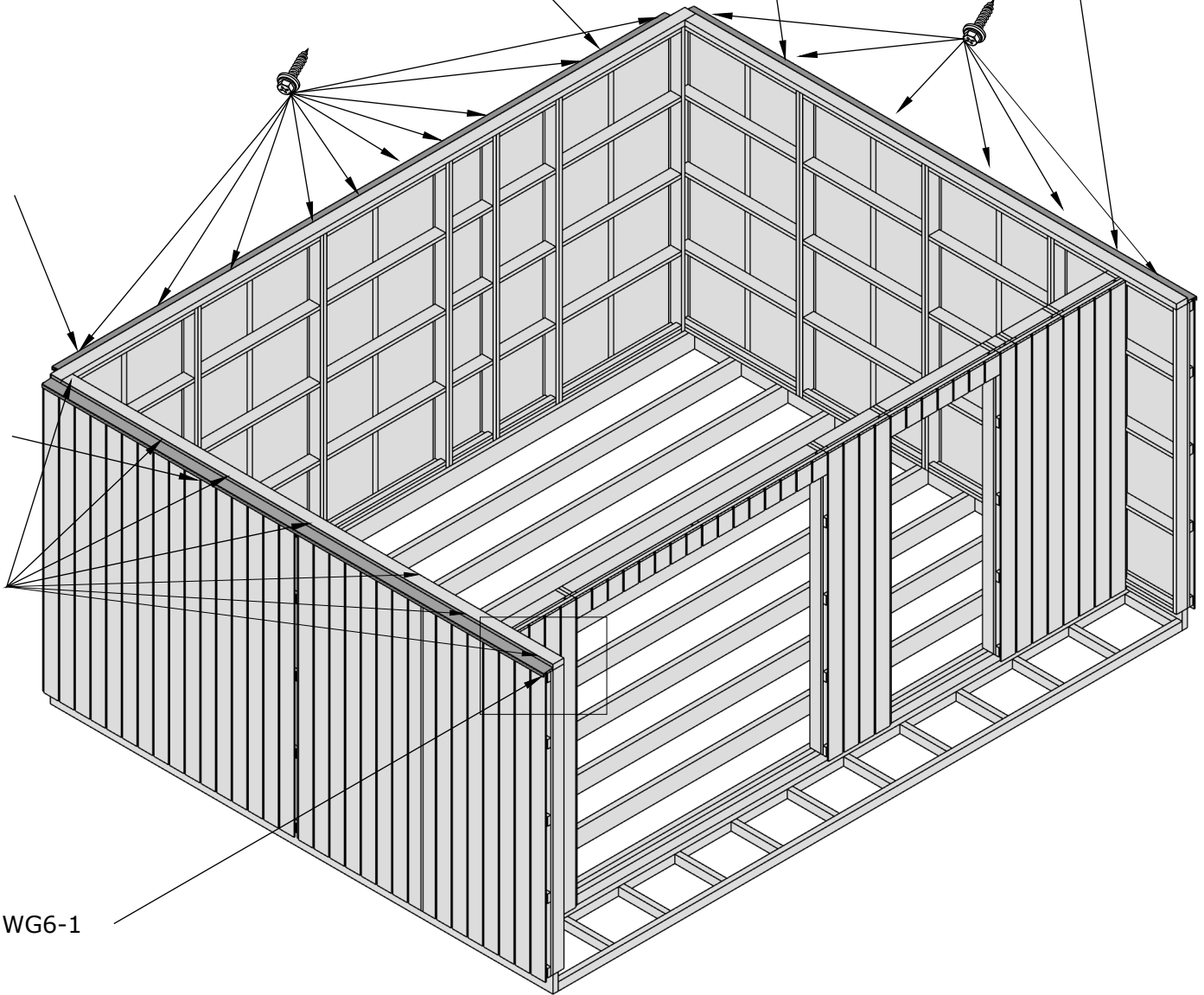

BM1 x1  
BM2 x1

Ø6X120 x10 

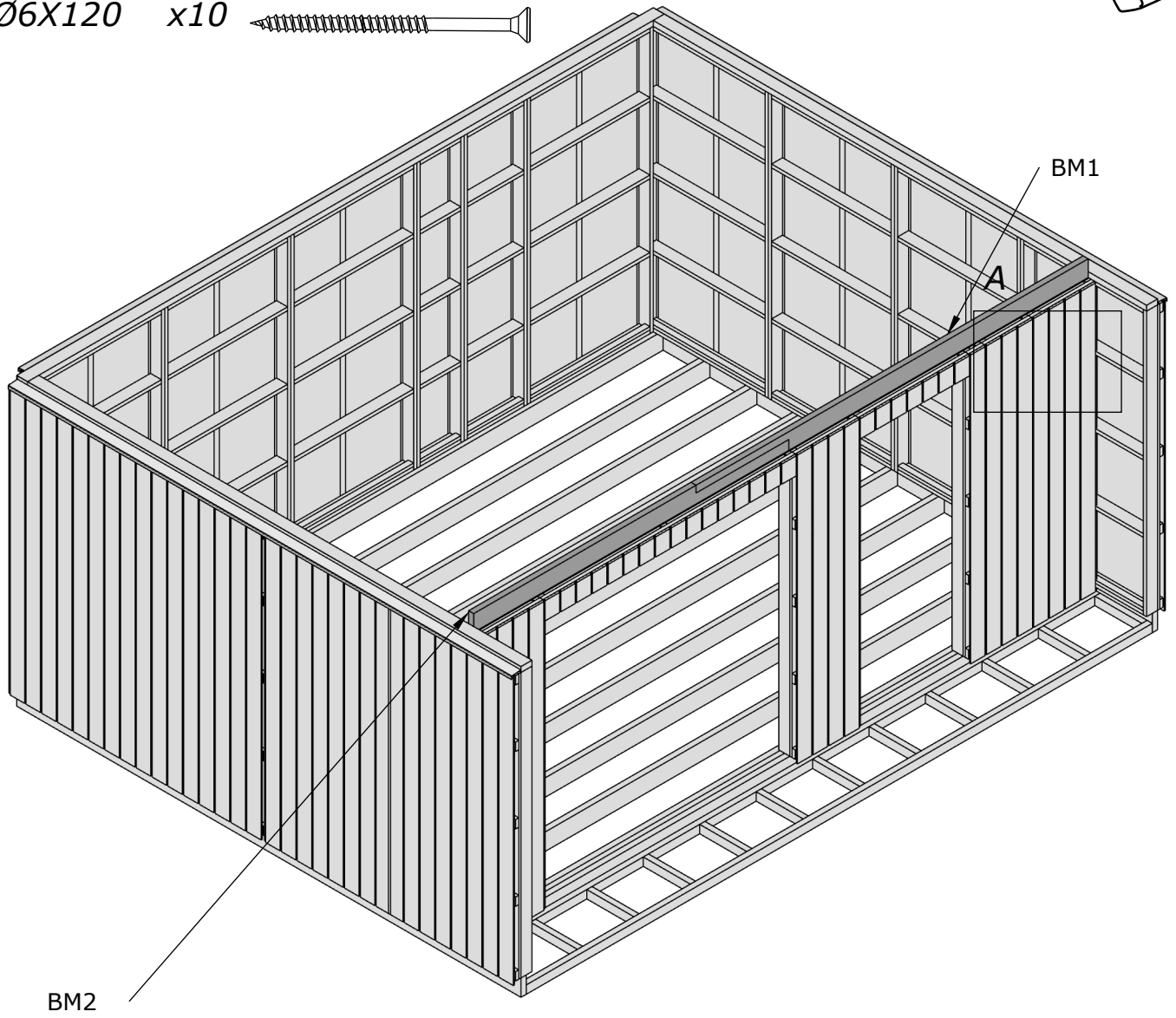
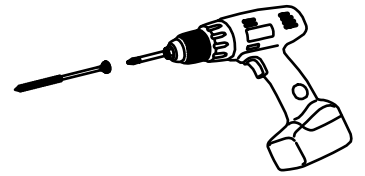

A

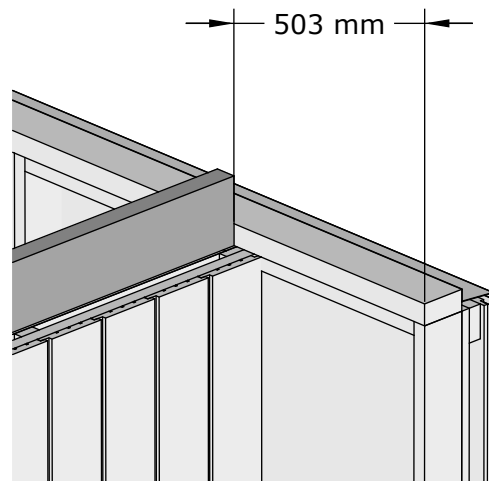
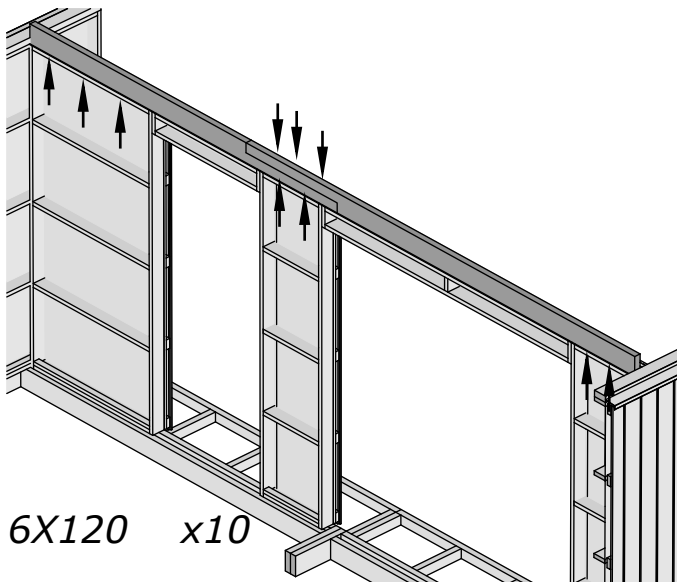

Sla1 x2

Sla1 x2

Ø4,5X60 x20

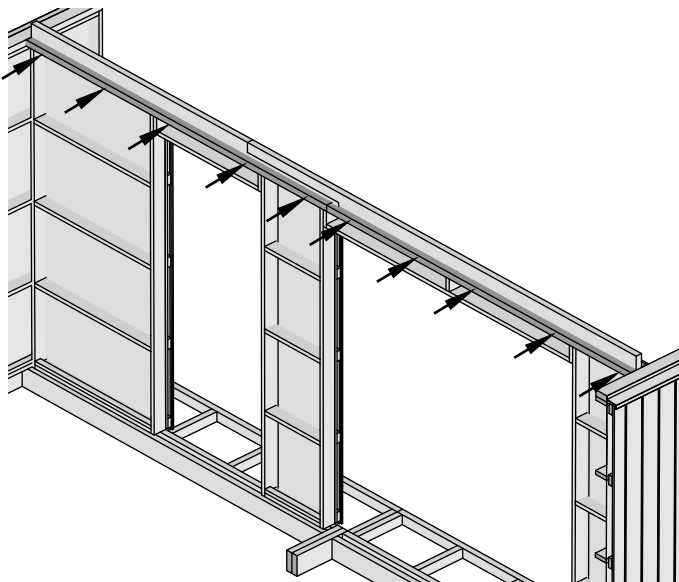
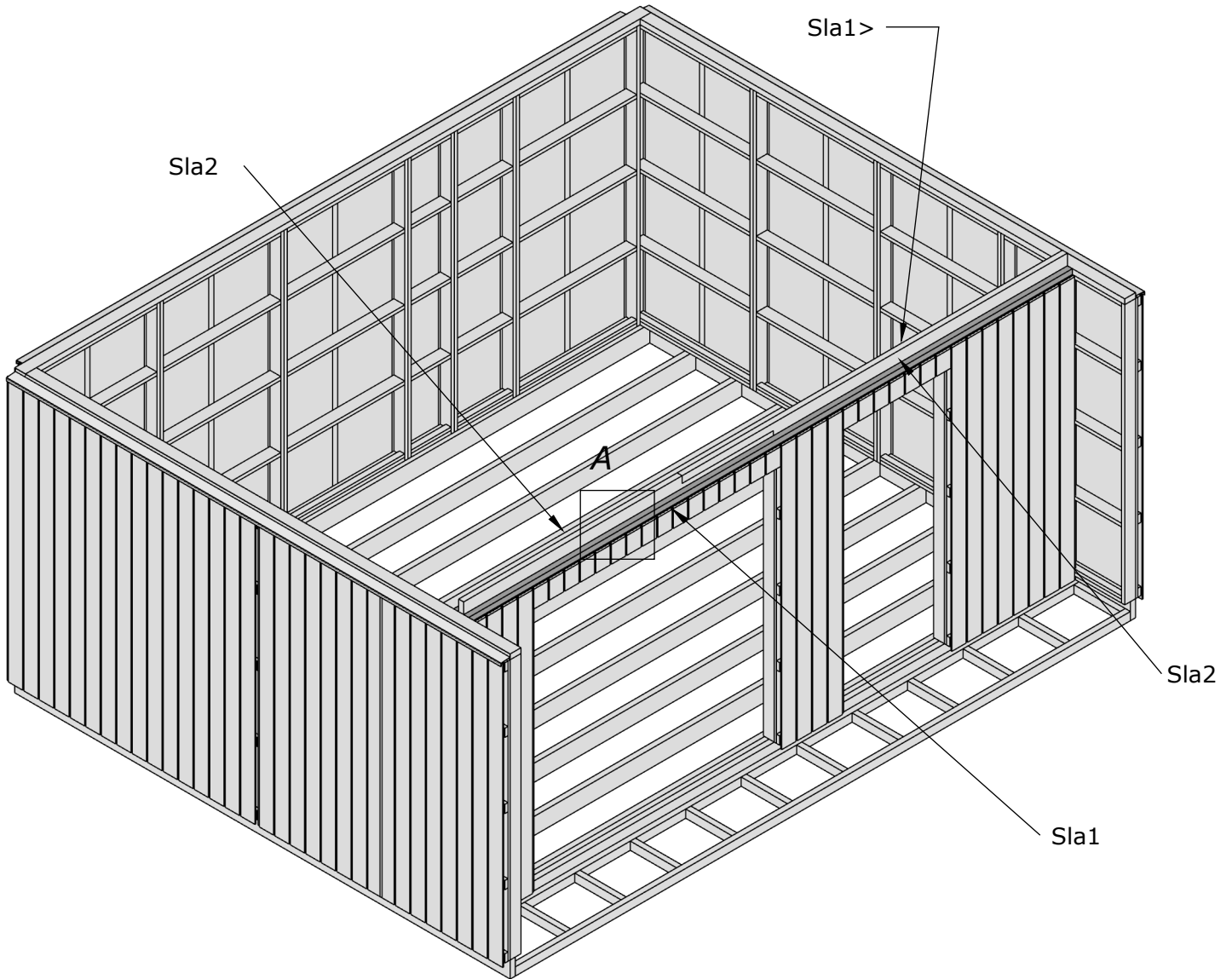
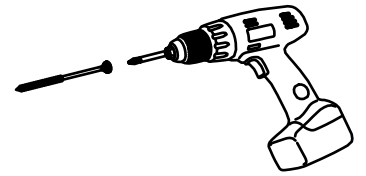
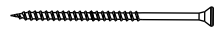

A

BM1-BM2

Sla1 - Sla2

Sla2 - Sla1

4,5x60

4,5x60

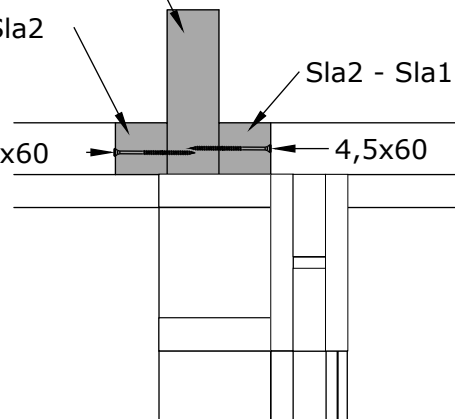

- ELEL1 x6
- ELEL2 x2
- ELEL3 x13
- ELEL4 x1
- ELEL5 x3

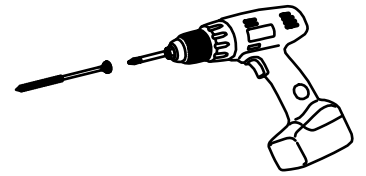

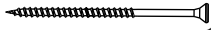
Ø4,5X60 x58 

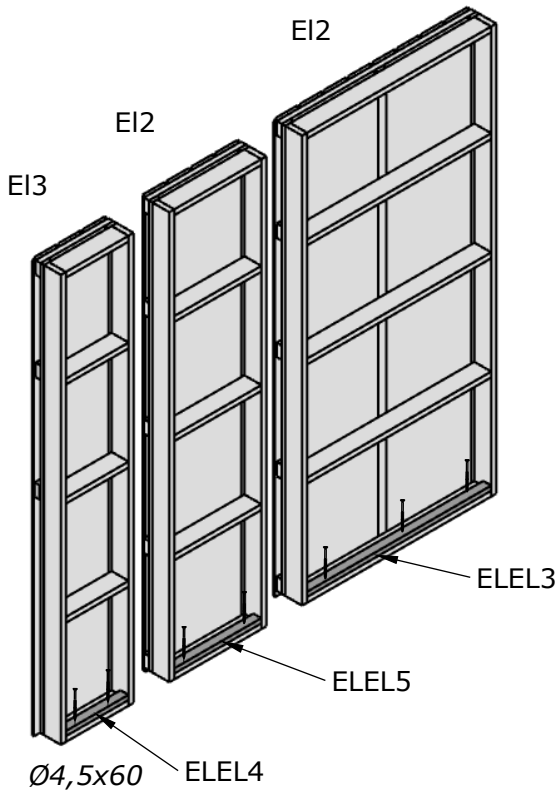
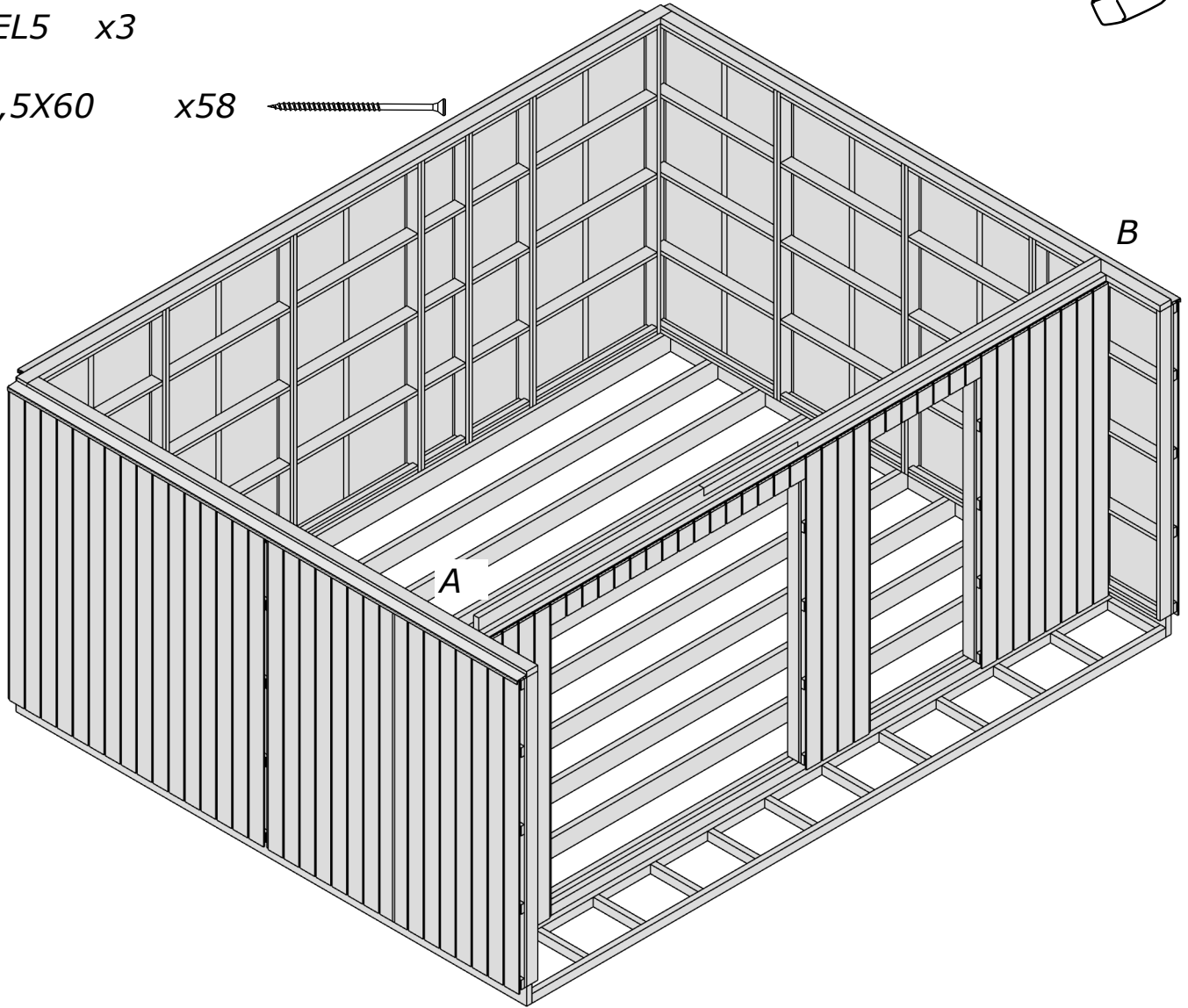

A - B

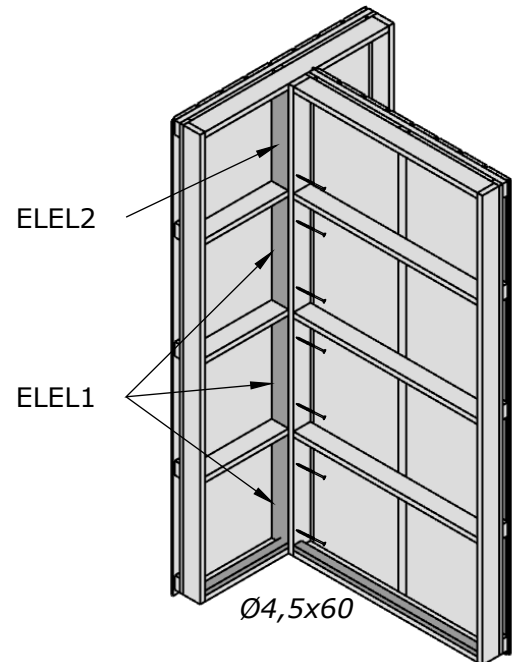

EI12 x2

EI13 x2

EI14 x2

EI15 x2

Ø4,5X60 x14

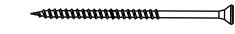

Ø5X80 x24

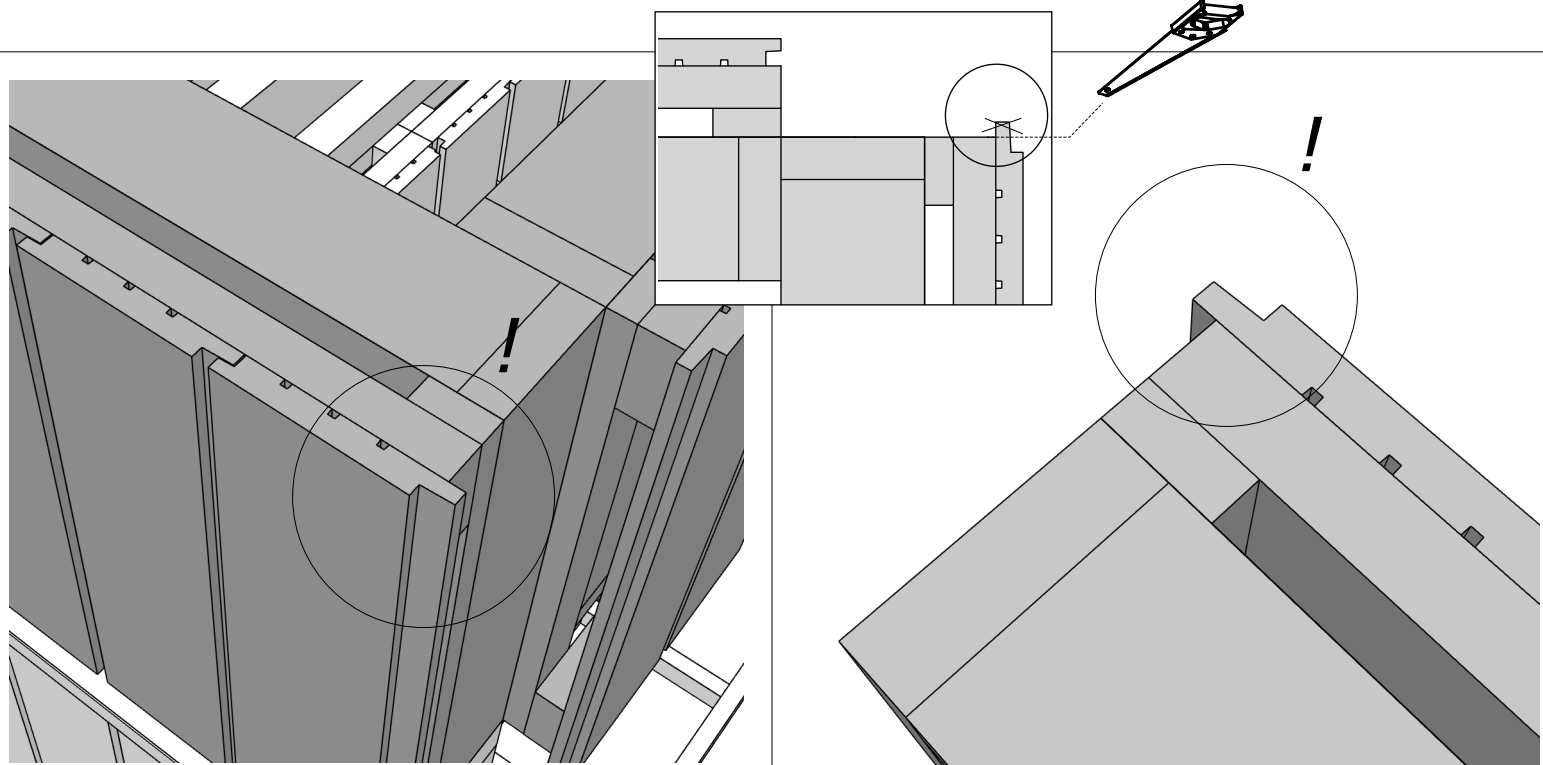
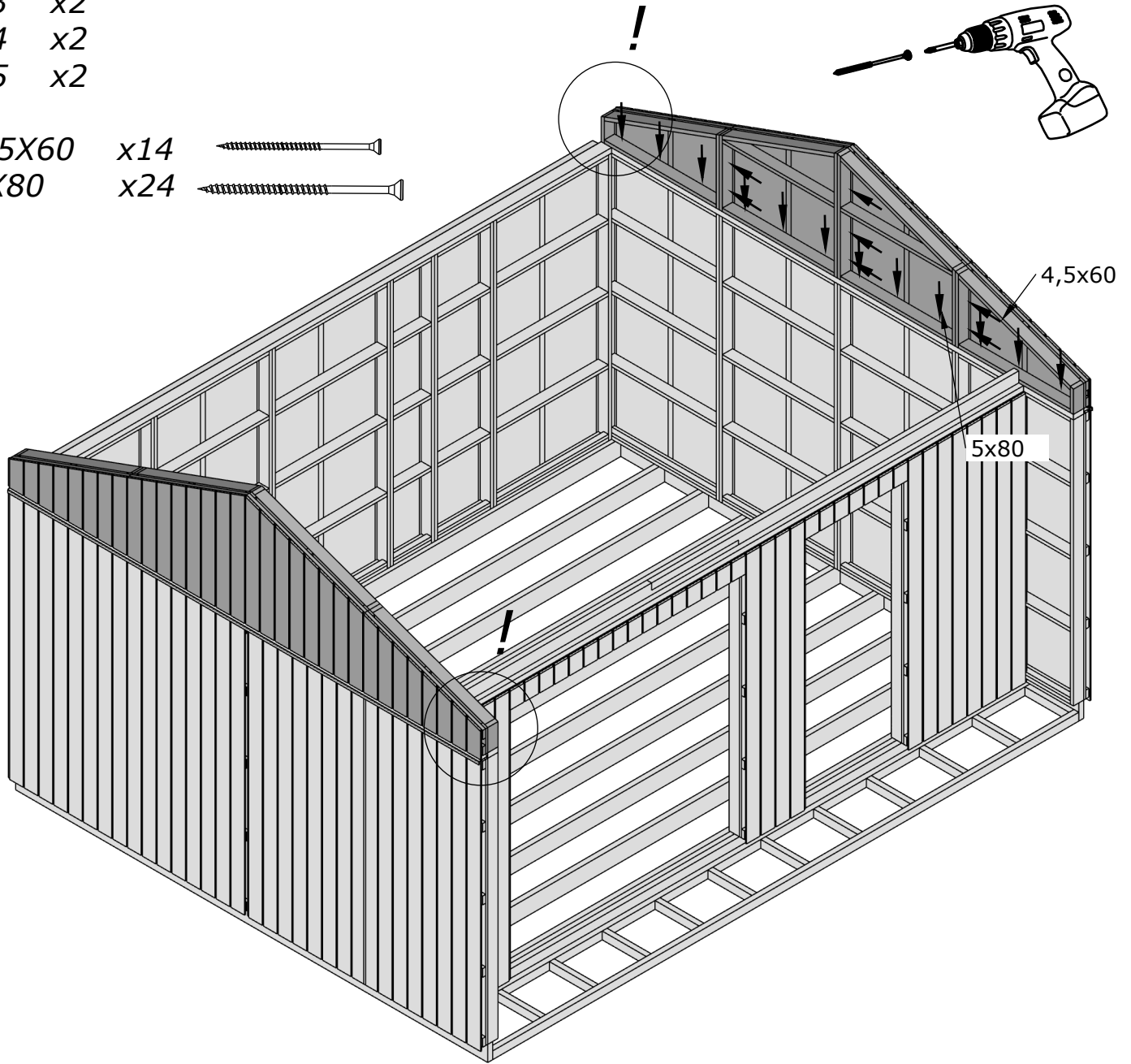
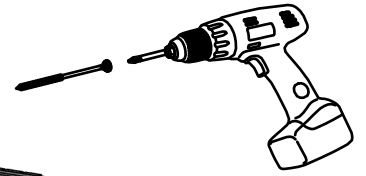
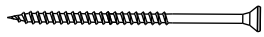

Ror1 x11  
Ror2 x22  
Ror3 x11  
Ror4 x11

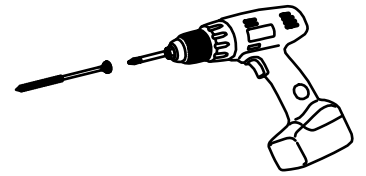

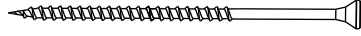
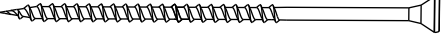
Ø6X160 x22  (A)  
Ø8X240 x88  (B)

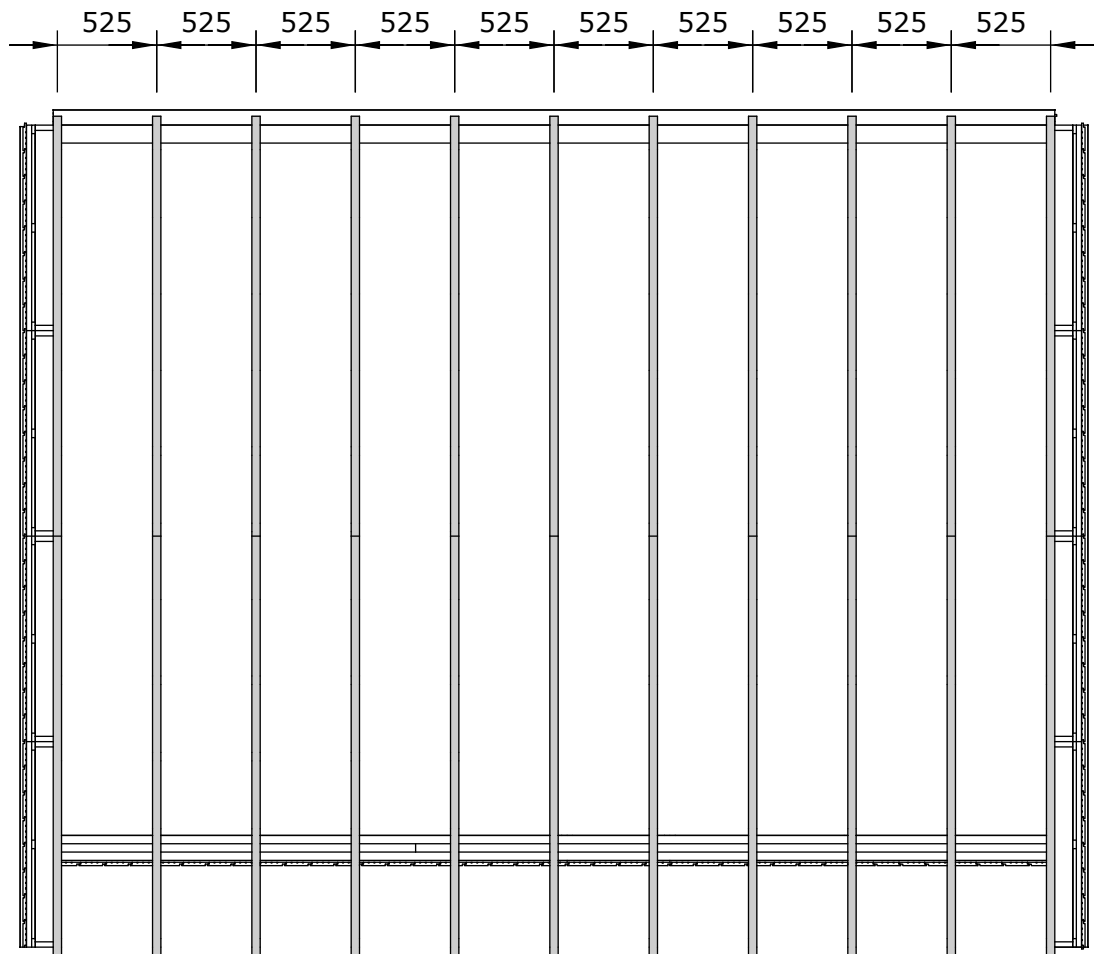
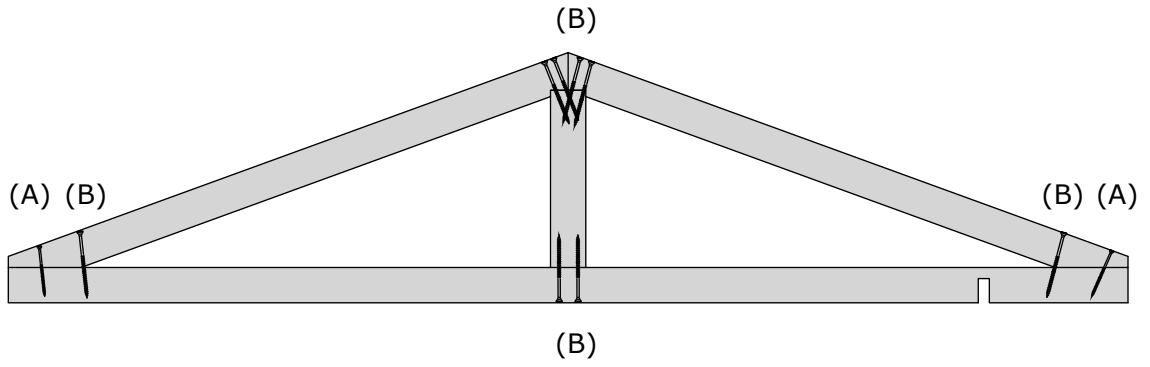

Ø5X80

x8

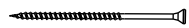

Ø6X120

x22

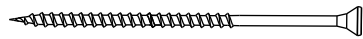

Ø6X160

x22

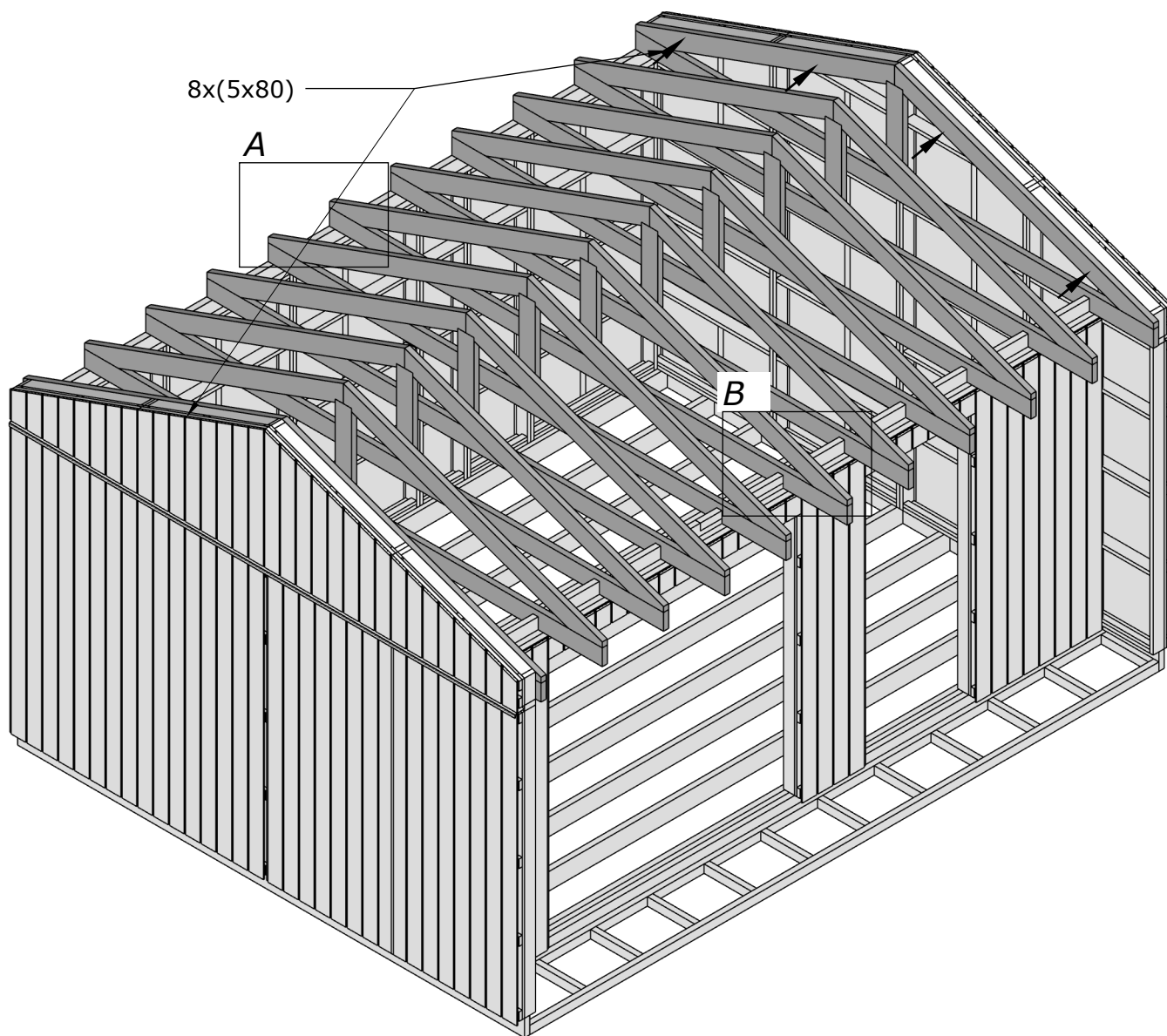
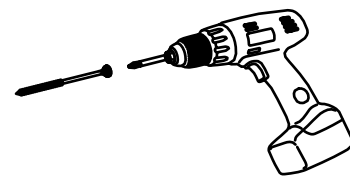

A

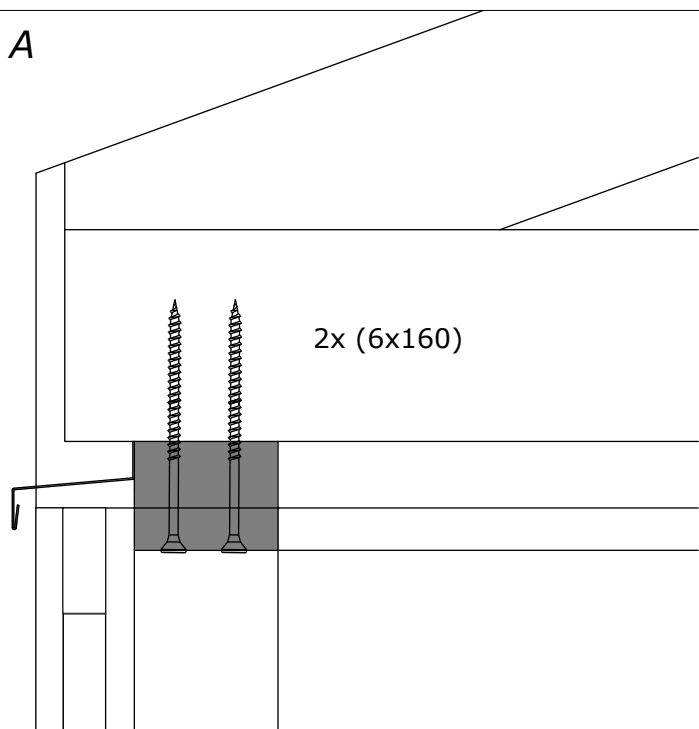

B

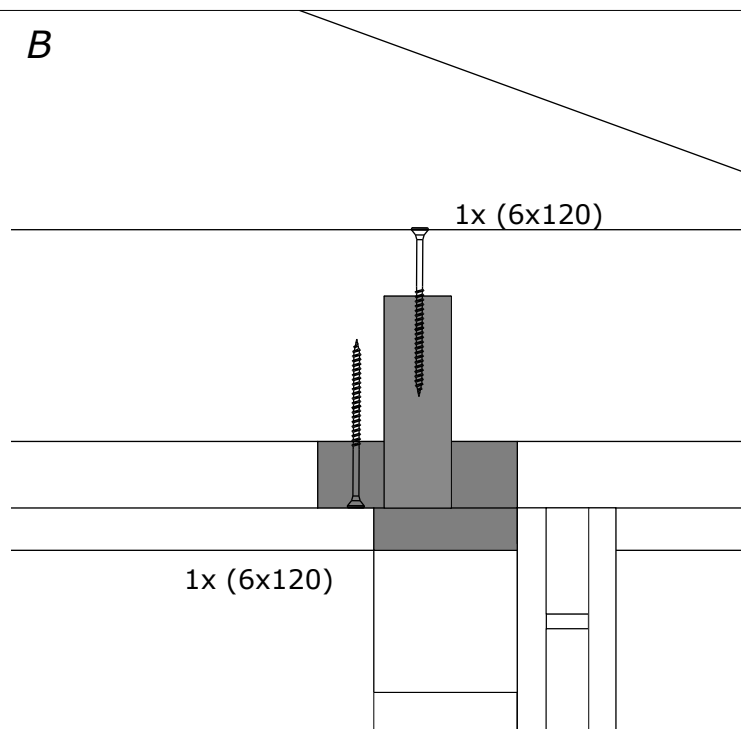

PST1 x4

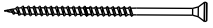
Ø5x80 x16 

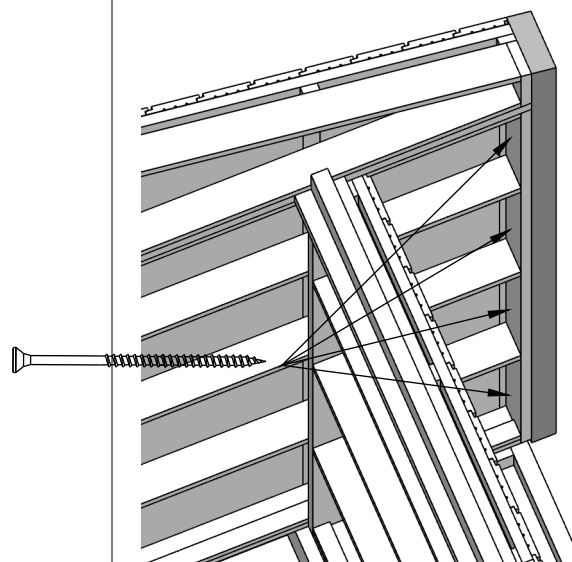
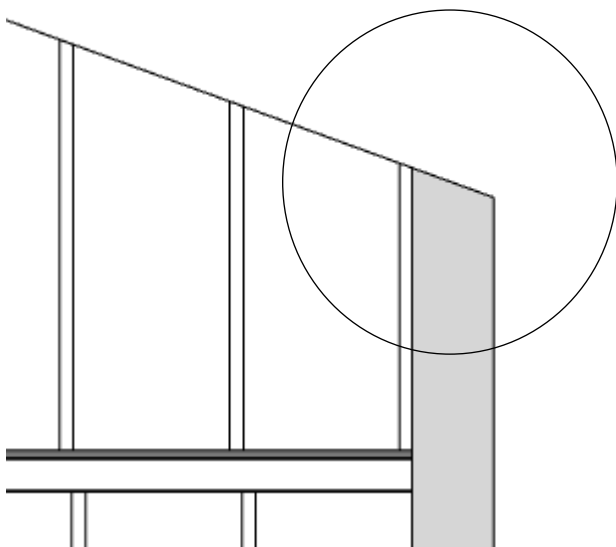
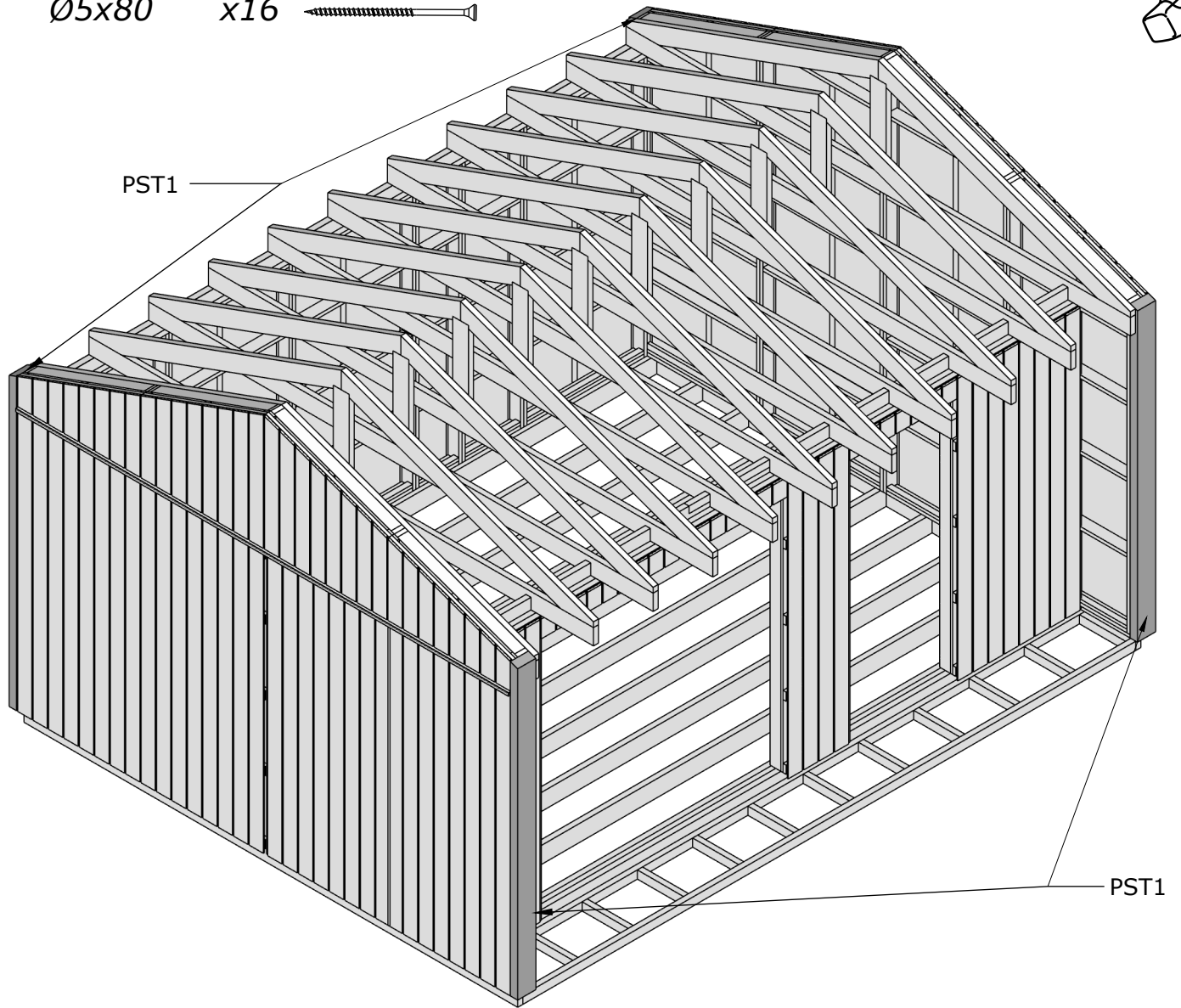
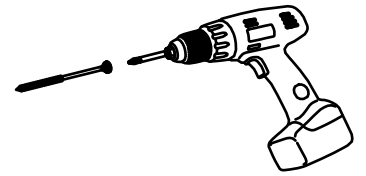

RB2-1 x56

RB2-2 x56

Ø3X70 x650

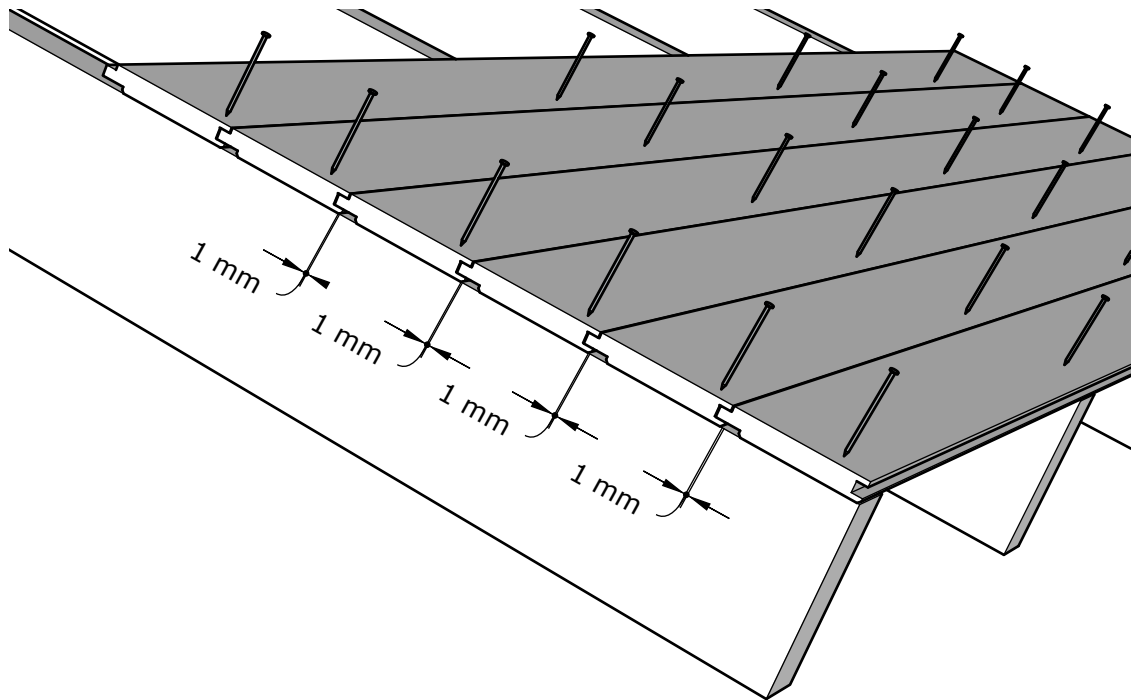
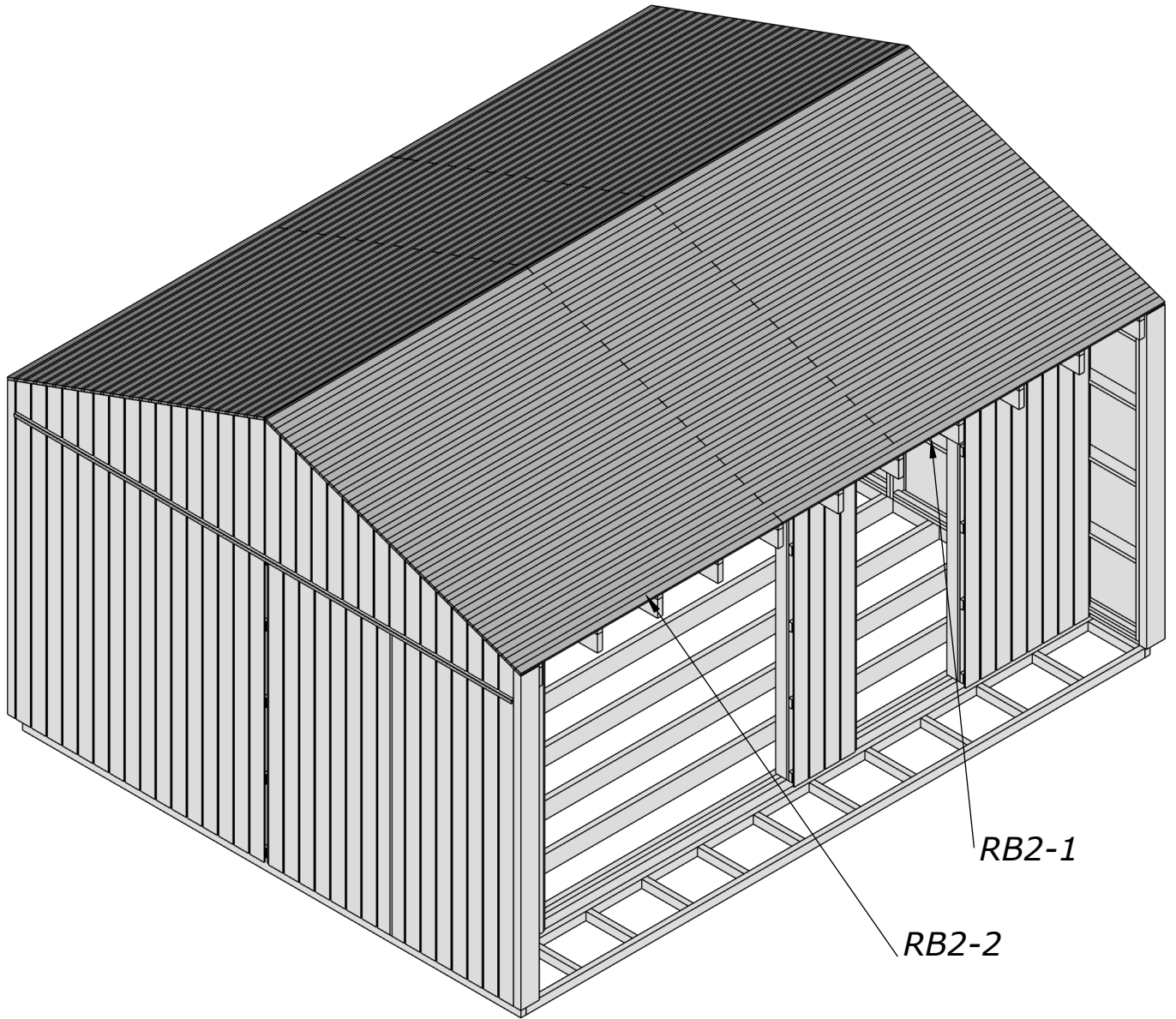
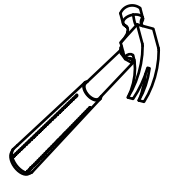
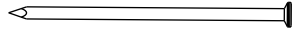

TB1-1 x9  
TB1-2 x9

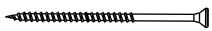
Ø4,5x60 x100 

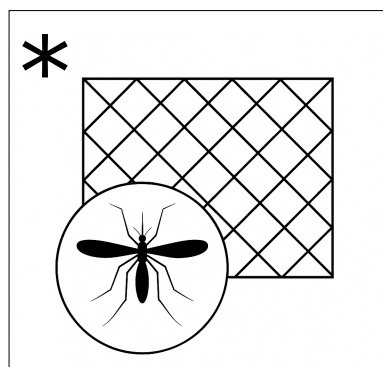
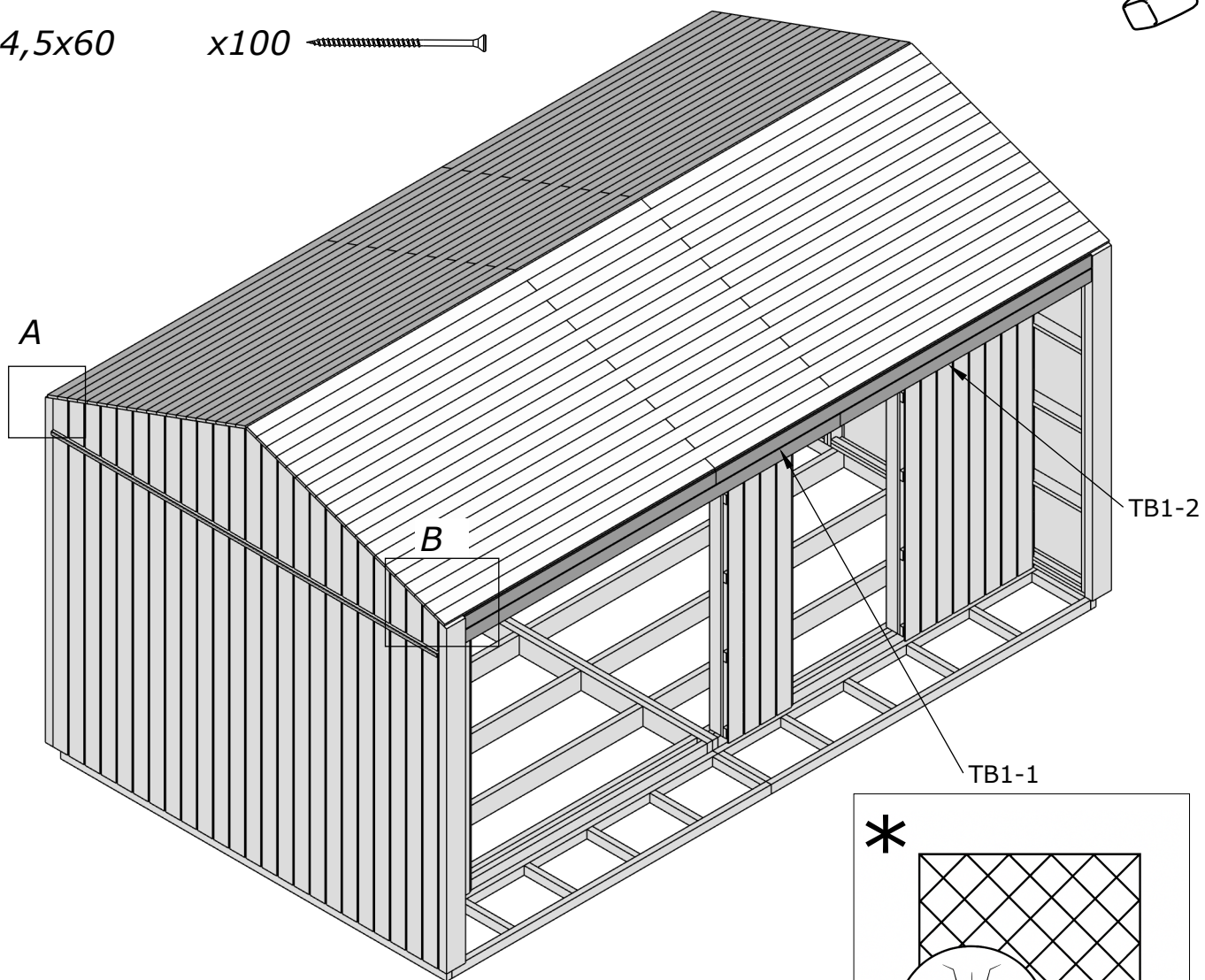
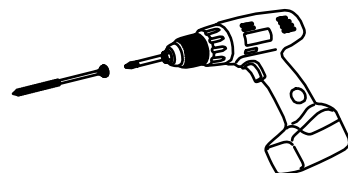

A

B

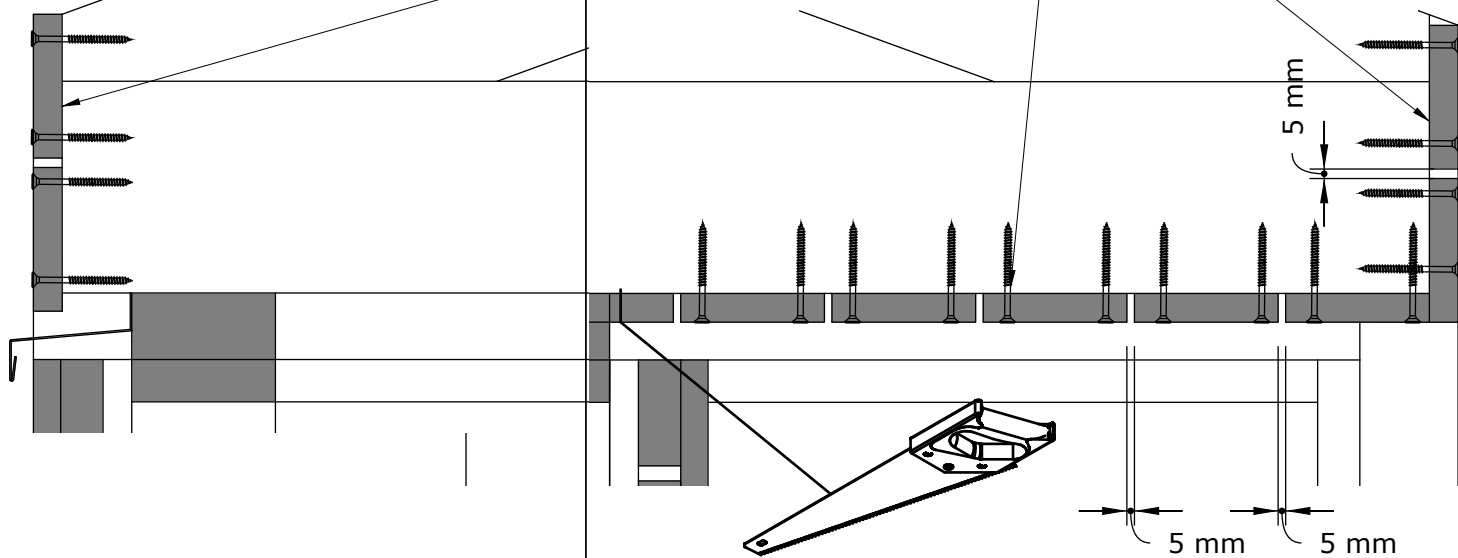

WG11-1 x4

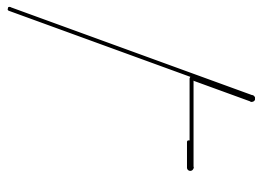

WG11-1

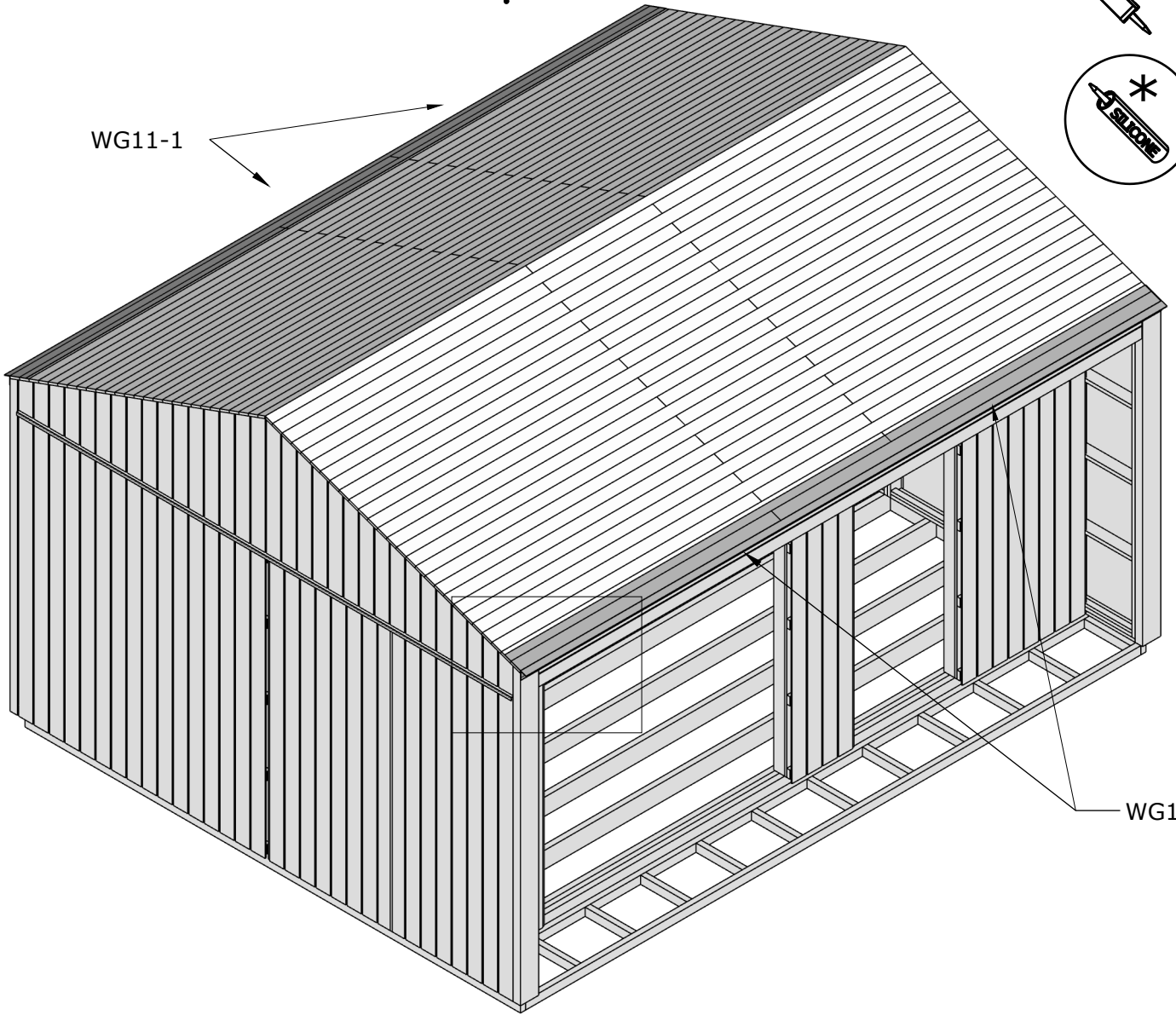

WG11-1

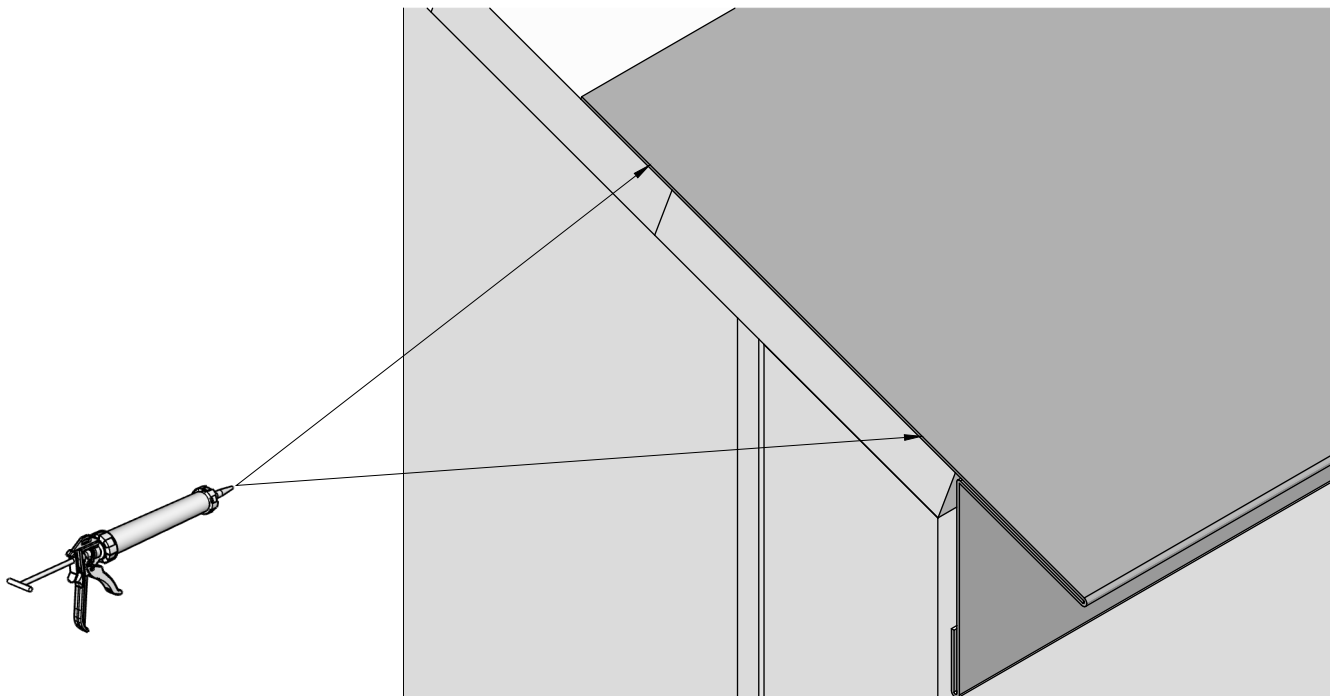

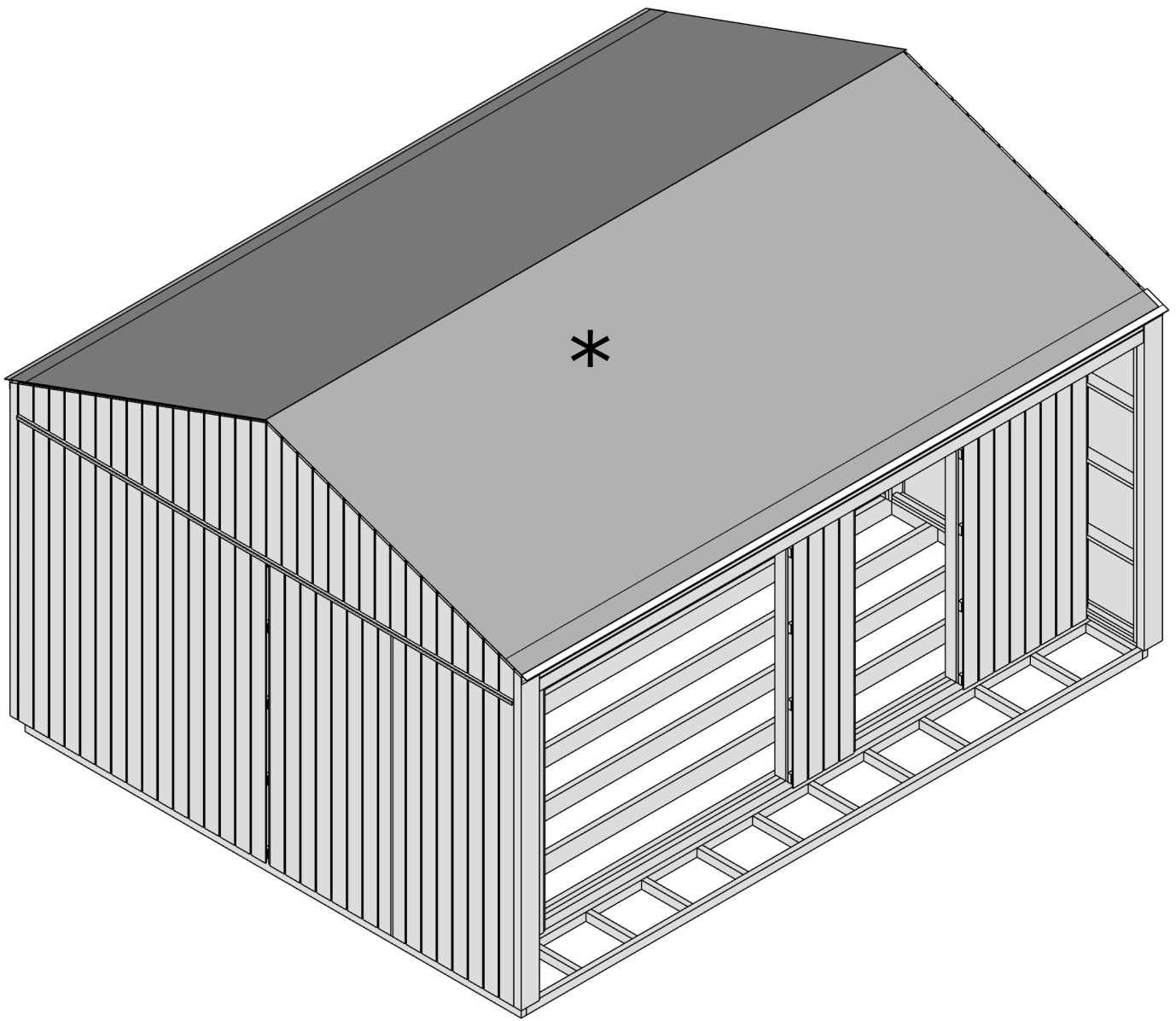

WG12-1 x4



Ø4,8x28 x40



WG12-1

WG12-1

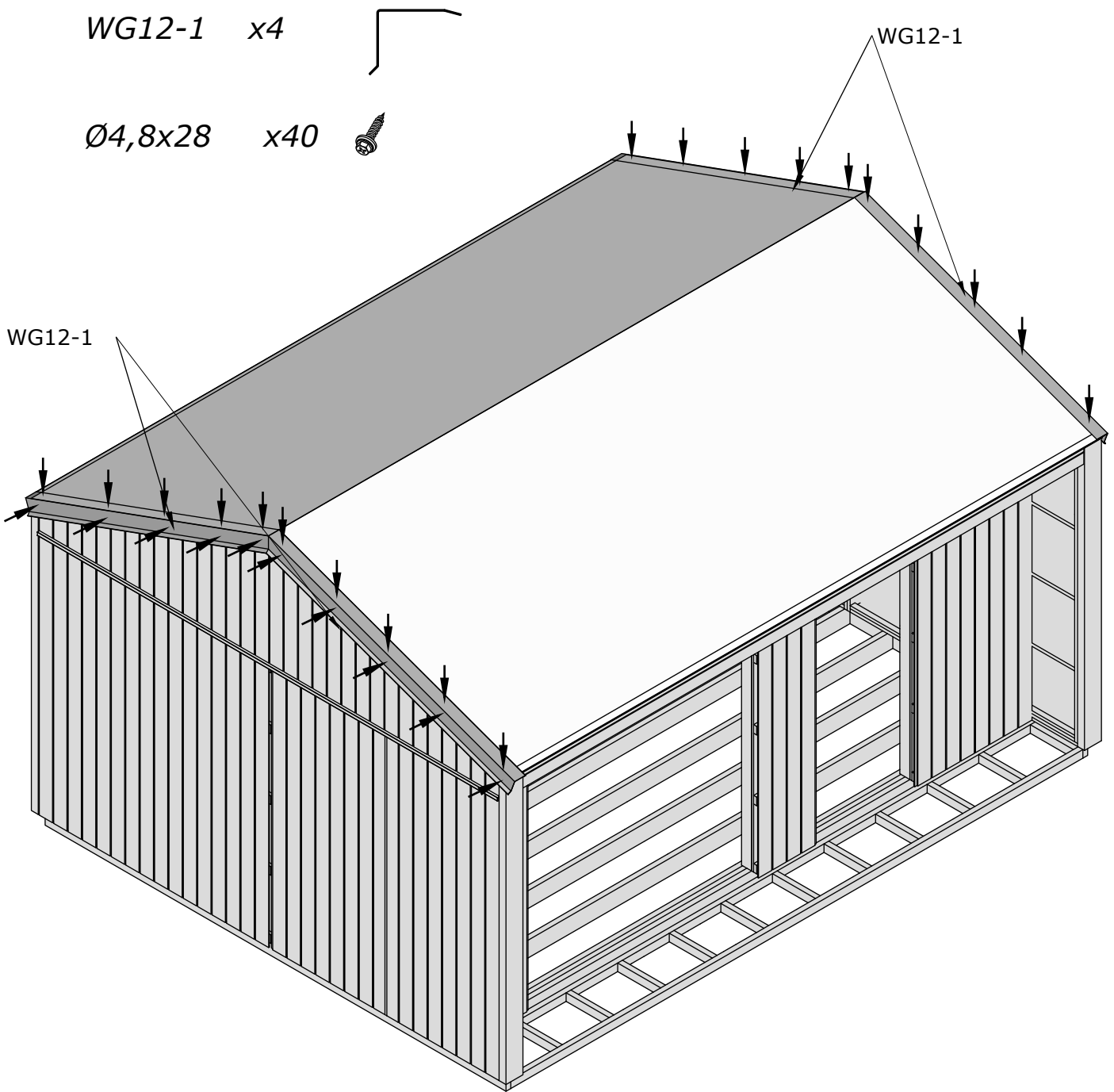

FB2-1 x60

Ø2,5x50 x740

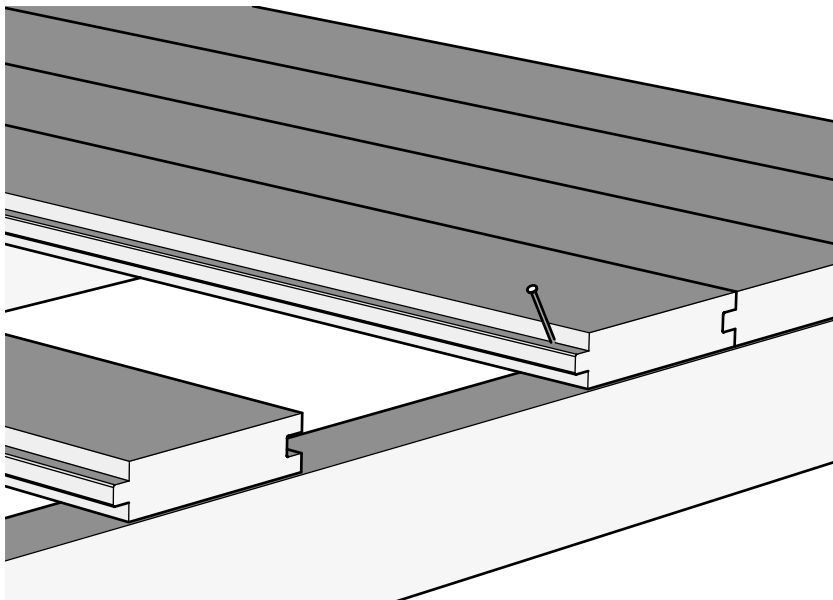
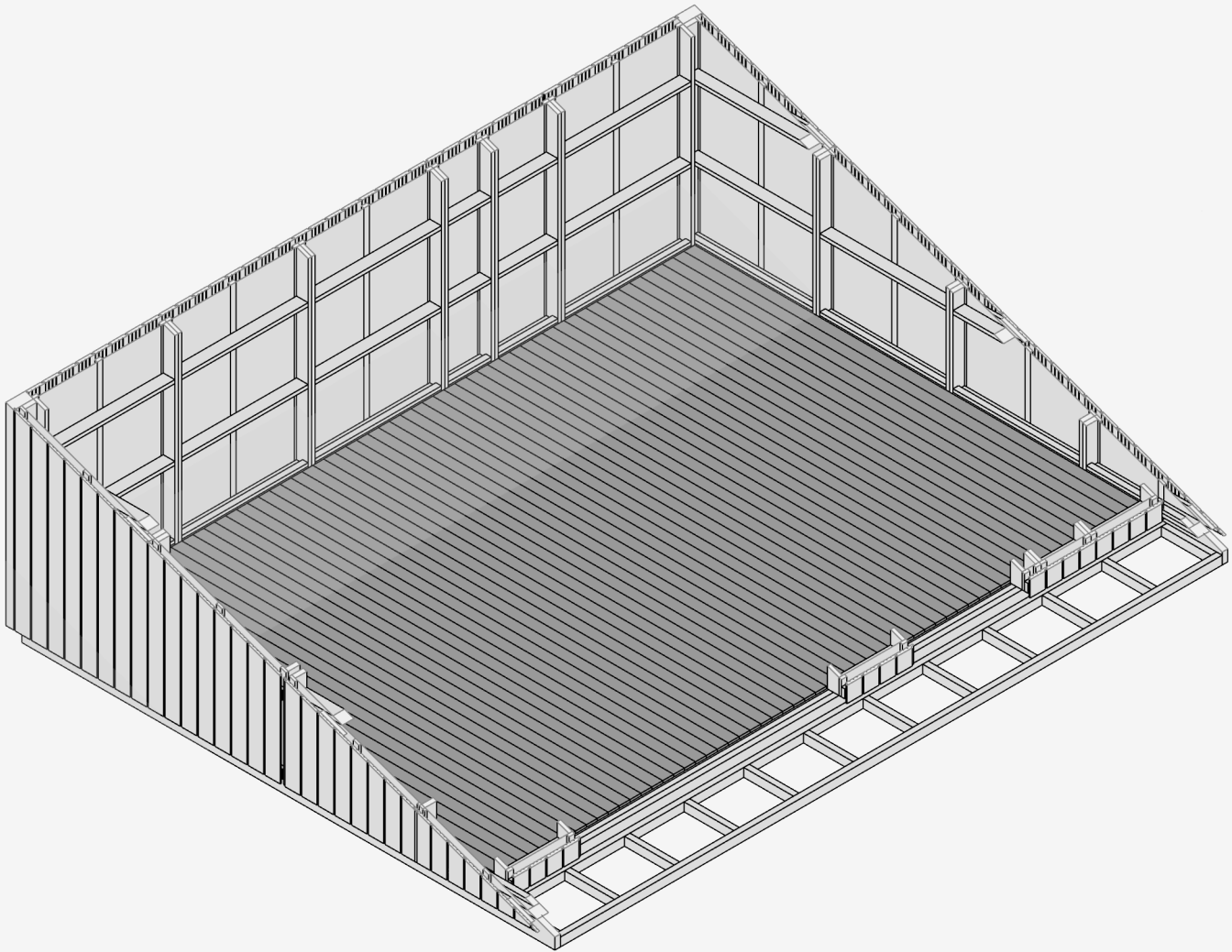
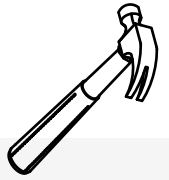
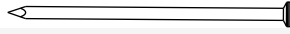

3 mm

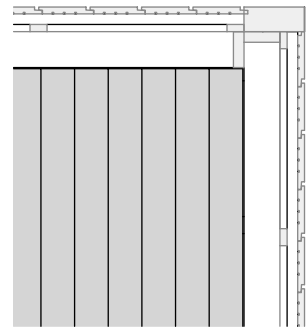

3 mm

UL4 x1

UL5 x1

Ø2,5x50 x6

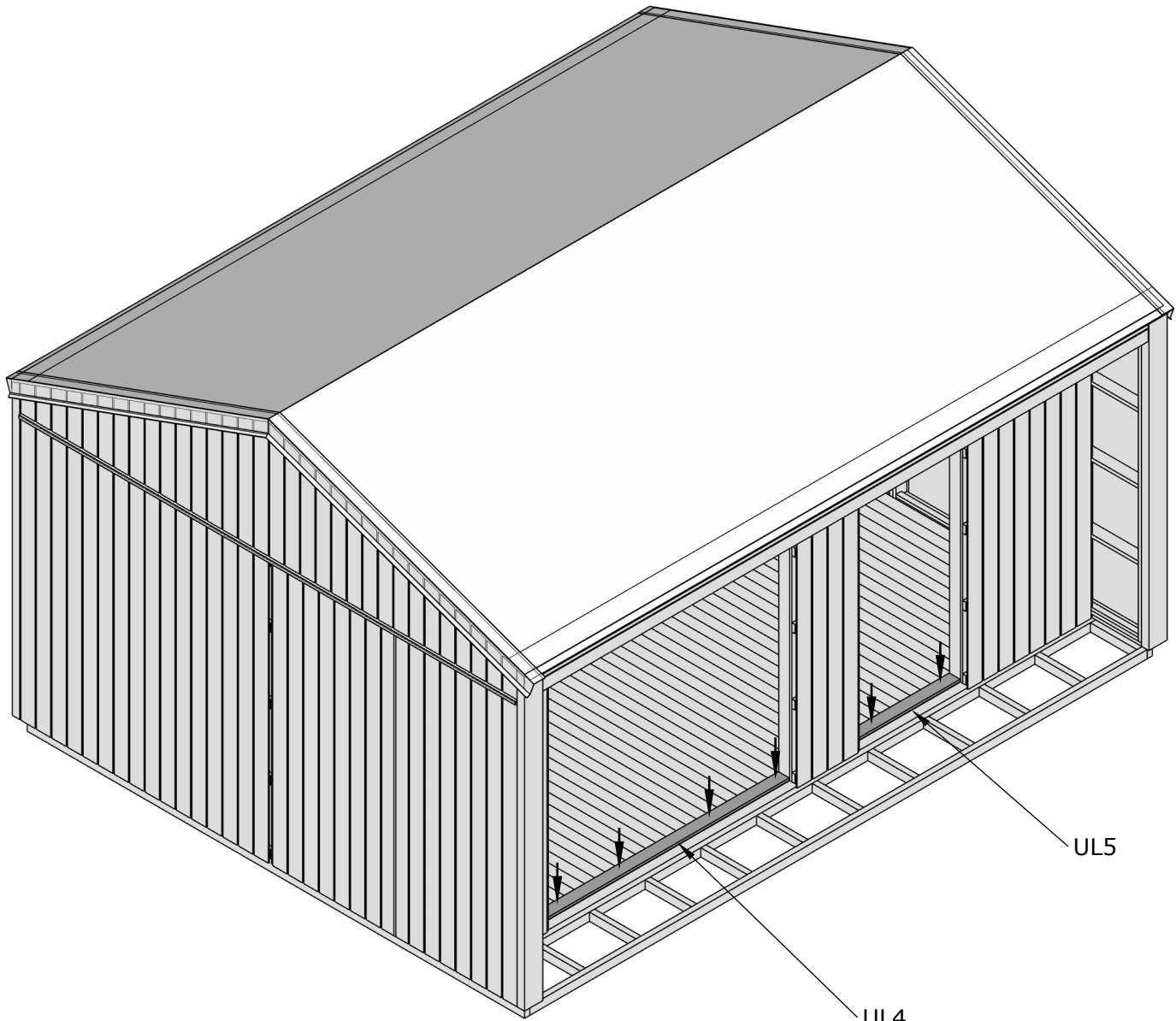
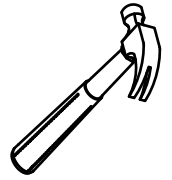
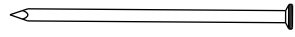

UL5

UL4

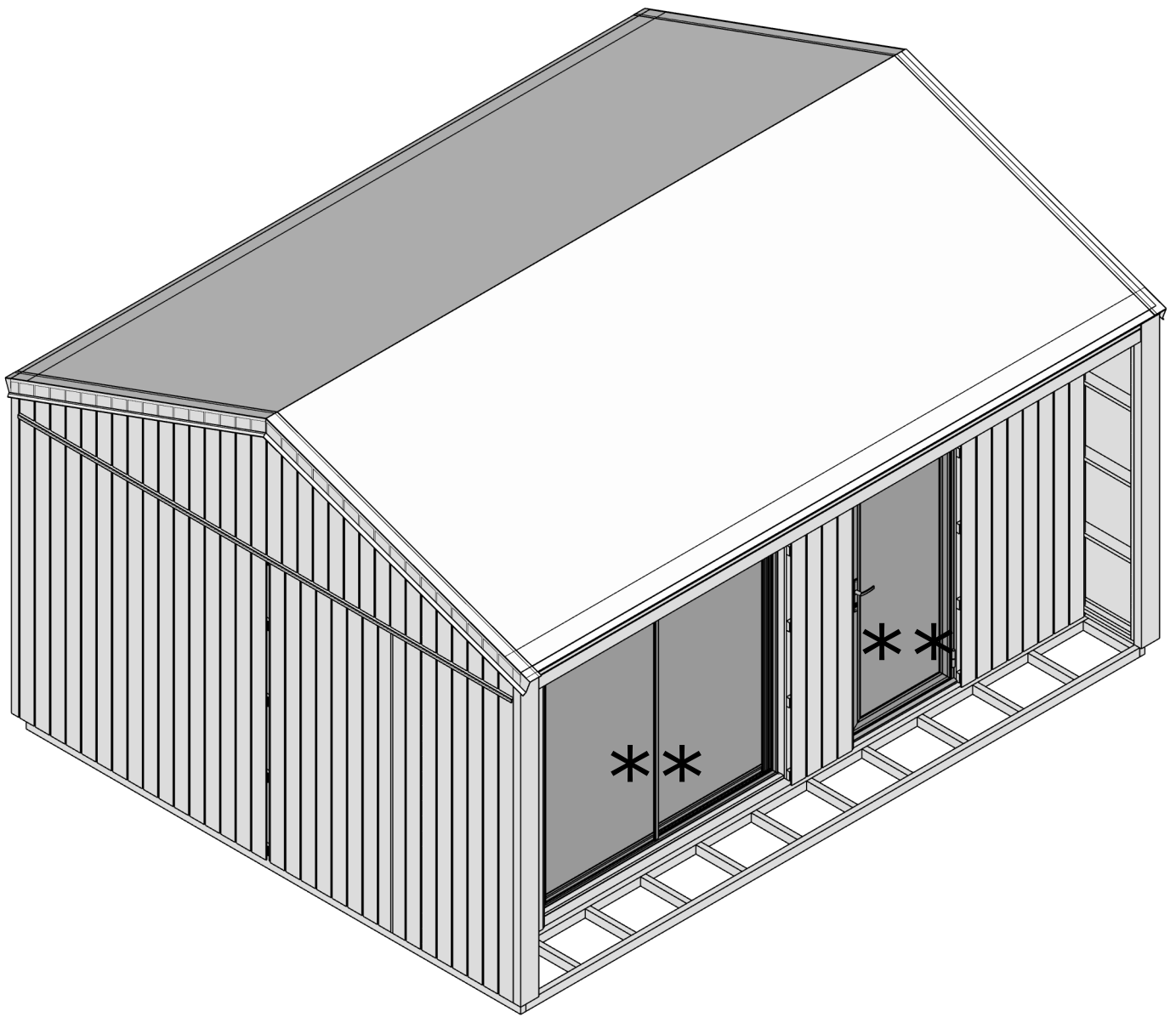

TB2-1 x5  
TB2-2 x5

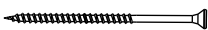
Ø4,5x60 x120 

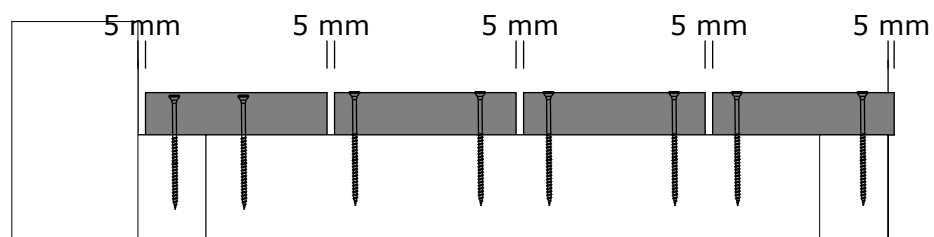
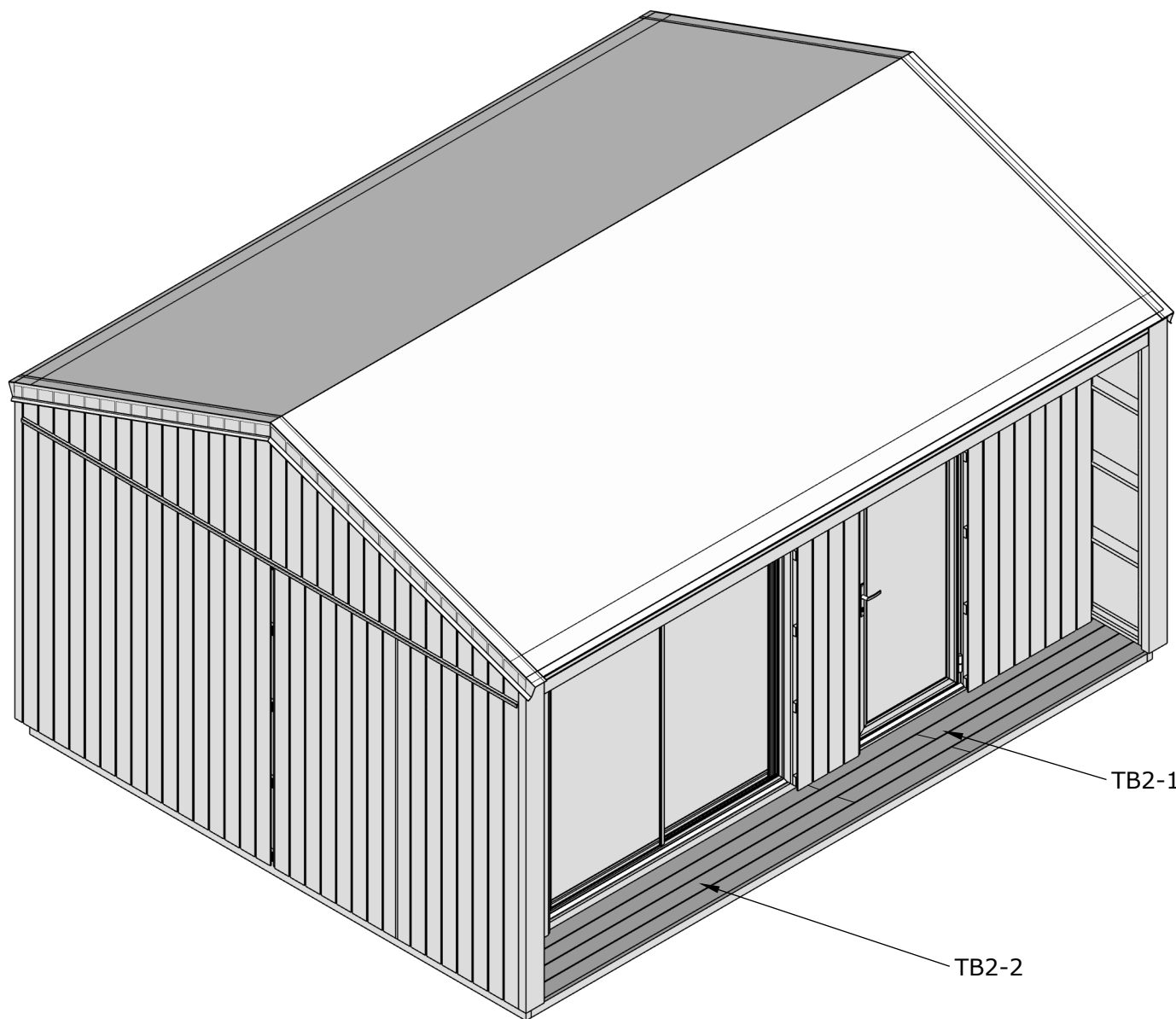

FB5-3 x10

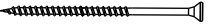
Ø4,5x60 x100 

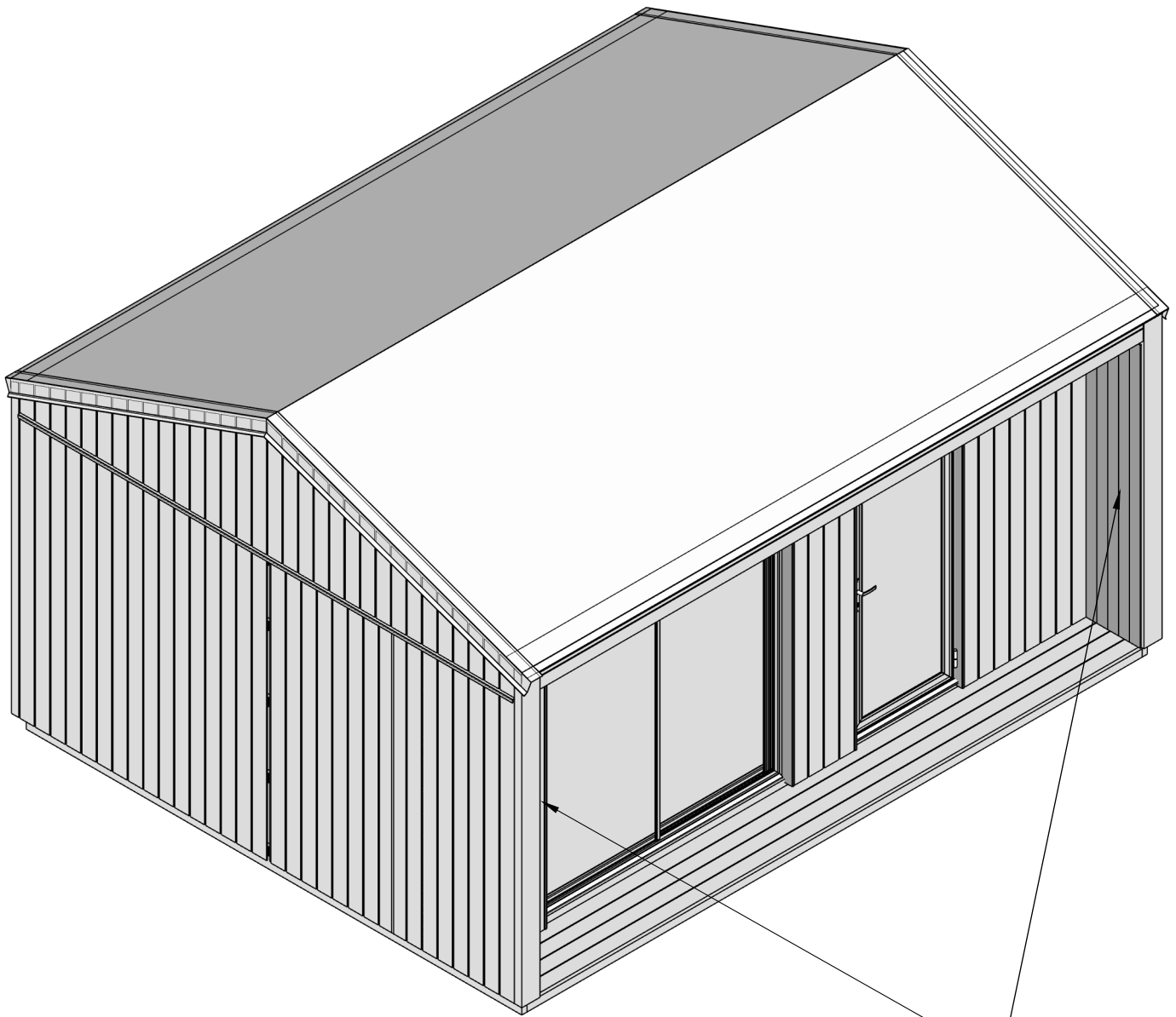
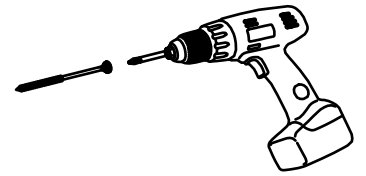

FB5-3

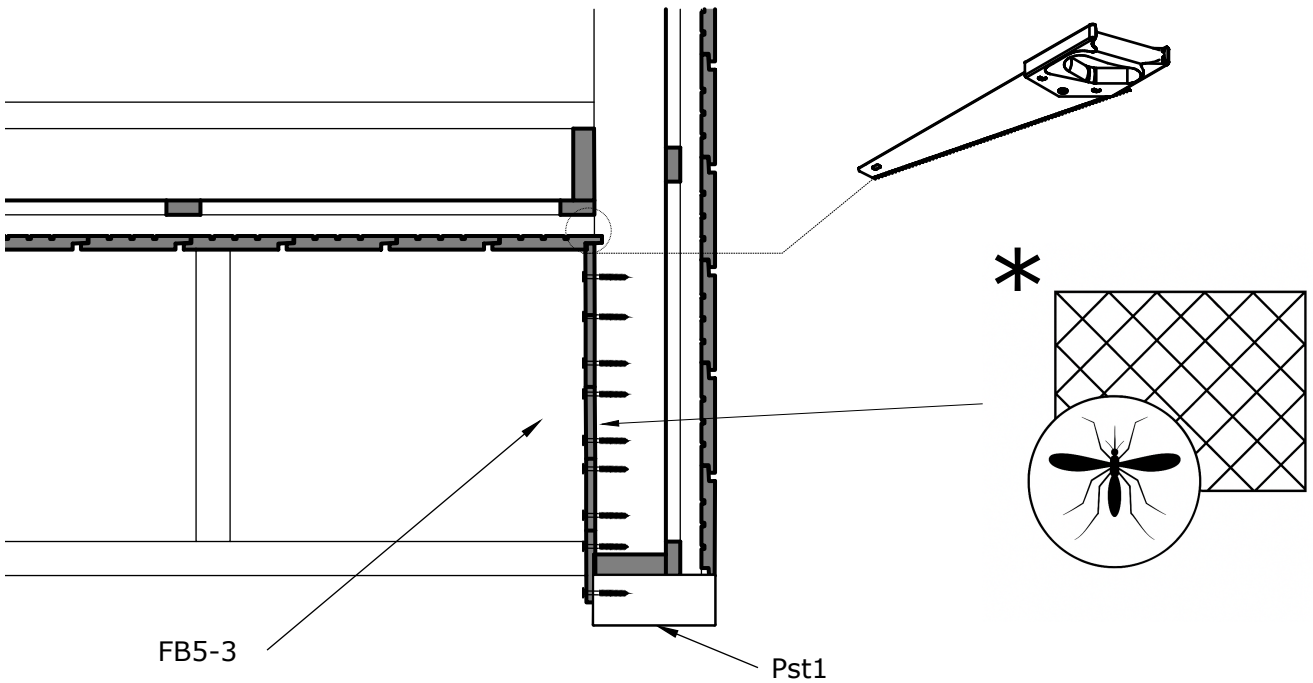

UL1 x4

UL2 x1

UL3 x1

Ø4,5x60 x22 