

# Assembly, installation and maintenance manual

Montage-, Aufbau- und Wartungsanleitung • Assemblage, manuel de montage et d'entretien • Montaje, instalación y mantenimiento • Manuale di montaggio, installazione e manutenzione • Monterings- og vedlikeholdsmanual • Monterings-, installations- och underhållsmanual • Kokoamis-, asennus- ja huolto-ohje • Vejledning for montering og vedligehold • Handleiding voor montage, installatie en onderhoud • Manual de montagem, instalação e manutenção • Návod k montáži, instalaci a údržbě • Instrukcja montażu, instalacji i konserwacji • Surinkimo, montavimo ir priežiūros vadovas • Montāžas, uzstādīšanas un apkopes rokasgrāmata • Руководство по сборке и обслуживанию • Montaaži-, paigaldus- ja säilitamise juhend



## Saga wall LA18-5521

<p><b>Factory inspection by</b> • Werkskontrolle durch • Contrôle à partir de l'usine par • Inspector de fábrica • Collaudato da • Fabrikkontroll utført av • Fabriksbesiktigat av • Tehtaan tarkastaja • Fabriks Kontrol udført af • Fabrikscontrole door • Inspeção de fábrica, por: • Zkontrolováno ve výrobním závodě • Kontrola fabryczna do • Apžiūrą gamykloje atliko • Rūpnīcas pārbaudi veicis • Заводской контроль • Tehase kontroll teostatud:</p> <p>.....</p>	<p><b>Date</b> • Datum • Date • Fecha • Data • Dato • Datum • Päiväys • Dato • Datum • Data • Datum • Data • Datums • Data • Дата • Kuupäev:</p>
	<p><b>Pack number</b> • Pack Nr. • Packet n° • Bulto N° • Pacco N. • Serienr • Produktionsnummer • Pakettinro • Pakke nr. • Pak nr. • Número de embalagem • Číslo balení • Numer opakowania • Pakuotės numeris • Iepakojuma numurs • Упаковочный номер • Pakinumber:</p>



[www.palmako.ee/information-hub](http://www.palmako.ee/information-hub)

**English:** Before installing and using the product, please read the instructions and warranty terms at [www.palmako.ee/information-hub](http://www.palmako.ee/information-hub) to guarantee proper installation and long-lasting performance.

**Deutsch:** Wichtig! Bitte vor Aufbau und Nutzung des Produkts unbedingt die detaillierte Montageanleitung sowie die Garantiebedingungen unter [www.palmako.ee/information-hub](http://www.palmako.ee/information-hub) lesen, um eine fachgerechte Montage und eine lange Funktionssicherheit zu gewährleisten.

**Français:** Avant d'installer et d'utiliser le produit, veuillez lire les instructions et les conditions de garantie sur [www.palmako.ee/information-hub](http://www.palmako.ee/information-hub) afin de garantir une installation correcte et la longévité du produit.

**Español:** Antes de instalar y utilizar el producto, lea las instrucciones y las condiciones de garantía en [www.palmako.ee/information-hub](http://www.palmako.ee/information-hub) para asegurar una instalación correcta y una larga vida útil del producto.

**Italiano:** Prima di installare e utilizzare il prodotto, leggere le istruzioni e le condizioni di garanzia su [www.palmako.ee/information-hub](http://www.palmako.ee/information-hub) per garantire una corretta installazione e prestazioni durature.

**Norsk:** Før montering og bruk av produktet, vennligst les monteringsanvisningene og garantivilkårene på [www.palmako.ee/information-hub](http://www.palmako.ee/information-hub) for å sikre korrekt montering og fremtidig holdbarhet.

**Svenska:** Innan du installerar och använder produkten, vänligen läs instruktionerna och garantivillkoren på [www.palmako.ee/information-hub](http://www.palmako.ee/information-hub) för att säkerställa korrekt installation och produktens långvariga hållbarhet

**Suomi:** Ennen tuotteen asentamista ja käyttämistä, lue ohjeet ja takuehdot osoitteessa [www.palmako.ee/information-hub](http://www.palmako.ee/information-hub) varmistaaksesi oikean asennuksen ja pitkäkestoisen toiminnan.

**Русский:** Перед установкой и использованием изделия ознакомьтесь с инструкцией и условиями гарантии на сайте [www.palmako.ee/information-hub](http://www.palmako.ee/information-hub), чтобы гарантировать правильную установку и долговечность изделия.

**Eesti:** Enne toote paigaldamist ja kasutuselevõttu lugege palun juhiseid ja garantiitingimusi aadressil [www.palmako.ee/information-hub](http://www.palmako.ee/information-hub), et tagada nõuetekohane paigaldus ja toote pikk eluiga.

**Dansk (Oversat af AI):** Læs venligst instruktionerne og garantibetingelserne på [www.palmako.ee/information-hub](http://www.palmako.ee/information-hub), før du installerer og bruger produktet, for at garantere korrekt installation og langvarig ydeevne.

**Dutch (Vertaald door AI):** Lees vóór de installatie en het gebruik van het product de instructies en garantievoorwaarden op [www.palmako.ee/information-hub](http://www.palmako.ee/information-hub) om een correcte installatie en langdurige werking te garanderen

**Português (Traduzido por IA):** Antes de instalar e utilizar o produto, leia as instruções e os termos de garantia em [www.palmako.ee/information-hub](http://www.palmako.ee/information-hub) para garantir uma instalação adequada e um desempenho duradouro.

**Čeština (Přeloženo umělou inteligencí):** Před instalací a použitím produktu si prosím přečtěte pokyny a záruční podmínky na [www.palmako.ee/information-hub](http://www.palmako.ee/information-hub), abyste zaručili správnou instalaci a dlouhodobý výkon.







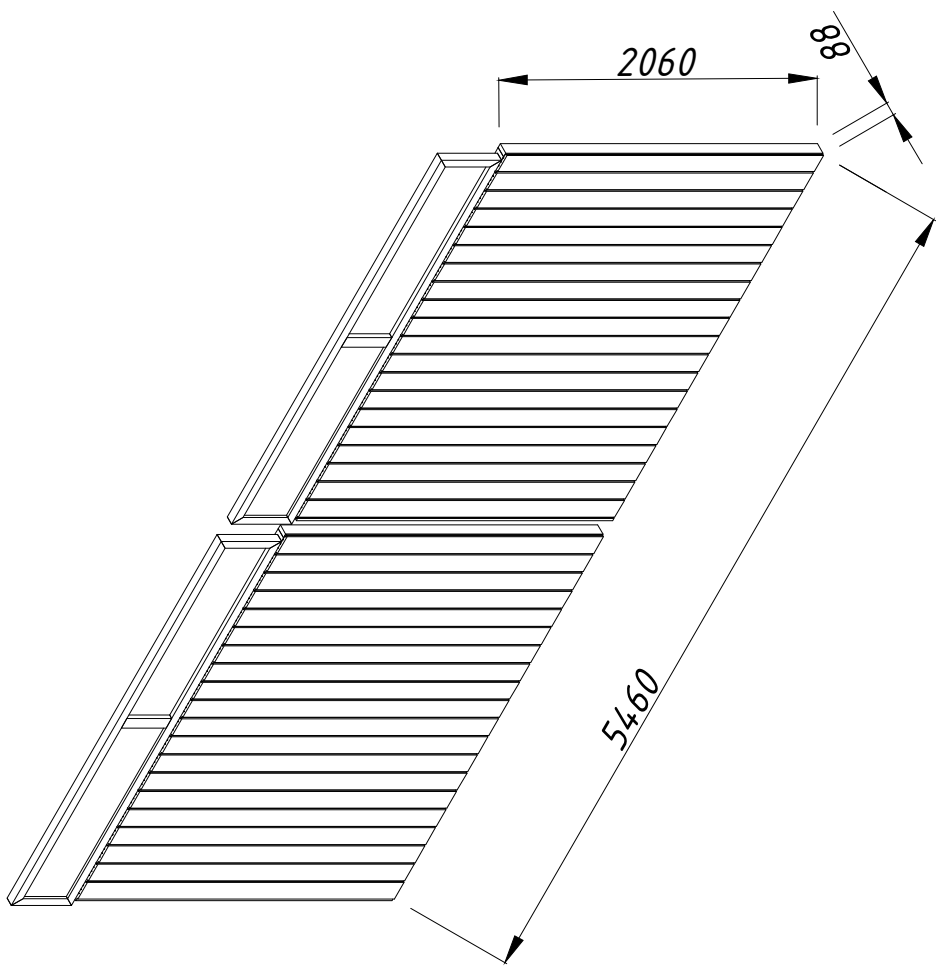



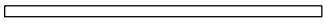
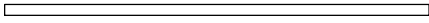

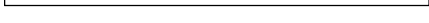

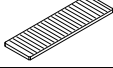
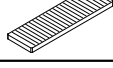

**Polski (Przetłumaczone przez AI):** Przed zainstalowaniem i użyciem produktu należy przeczytać instrukcję oraz warunki gwarancji dostępne na stronie [www.palmako.ee/information-hub](http://www.palmako.ee/information-hub), co pozwoli zagwarantować prawidłową instalację i długotrwałą wydajność.

**Latviešu (Mākslīgā intelekta tulkojums):** Pirms produkta uzstādīšanas un lietošanas, lūdzu, izlasiet instrukcijas un garantijas noteikumus vietnē [www.palmako.ee/information-hub](http://www.palmako.ee/information-hub), lai garantētu pareizu uzstādīšanu un ilgstošu darbību.

**Lietuviškai (Išvertė DI):** Prieš montuodami ir naudodami gaminį, perskaitykite instrukcijas ir garantijos sąlygas adresu [www.palmako.ee/information-hub](http://www.palmako.ee/information-hub), kad užtikrintumėte tinkamą montavimą ir ilgalaikį veikimą.

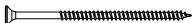
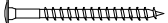

Object name	Drawing	Plan		1:1
		Customer	Log	Paper A4
<b>Palmako</b> AS Palmako Näituse 25, Tartu 50409, Estonia tel. +372 73 55 530 fax. +372 73 55 544 www.palmako.com <b>LEMEKS GROUP</b>	Drawn by	XXX		
	Date	19.02.2025	File	T07743-WALL-3D.dwg
				Page 1

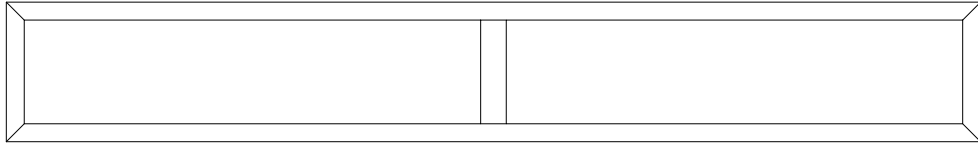
Pos	SPECIFICATION-STÜCKLISTE-NOMENCLATURE-ELEMENTI-ESPECIFICACIÓN LA18-5521	Pcs	Profile (mm)	Length (mm)
BM1	Beam- Balken- Poutre- Trave- Viga 	2	42x120	2790
Def1	Detail- Detail- Detail- Dettaglio- Detalle 	8	28x70	2040
Def2	Detail- Detail- Detail- Dettaglio- Detalle 	10	28x70	2730
Def3	Detail- Detail- Detail- Dettaglio- Detalle 	2	44x70	2730
IB1	Insulation battens- Distanzleiste- Lattes pour isolation- Listello di distanziamento- Listón para aislamiento 	12	28x45	2730
Pst1	Post- Pfosten- Poteau- Montante- Poste 	1	60x120	2055
Pst2	Post- Pfosten- Poteau- Montante- Poste 	1	60x120	531
EaE1	Slat- Leiste- Baguette- Listello- Listón 	2	45x45	2955
WP5-1	Wall panelling- Wandverkleidung- Revetement du mur- Rivestimento di muro- Revestimiento de pared 	41+3	135x18	2040
QKI-2-1	Wind barrier membrane- Windschutzmembran- Membrane pare vent- Membrana barriera antivento- Membrana cortavientos Wind barrier membrane- Windschutzmembran- Membrane pare vent- Membrana barriera antivento- Membrana cortavientos	4		2200
WG8-1	Water gutter- Wasserleiste- Rejet d'eau- Protección de lluvia- Protezione dalla pioggia- QP40x30x...HA 	4		2730
WG5-1	Water gutter- Wasserleiste- Rejet d'eau- Protección de lluvia- Protezione dalla pioggia- QP66x57x...HA 	2		2730
QPL20x100x2PET	Detail- Detail- Detail- Dettaglio- Detalle- 2mm 	32		
QPL20x100x3PET	Detail- Detail- Detail- Dettaglio- Detalle- 3mm 	32		
QNA2_2x50Zn	Nail- Nagel- Clou- Chiodo- Clavo- 2.5x50mm 	250		
QKRPP3x16Zn	Screw- Schraube- Vis- Vite- Tornillo- 3x16mm 	10		
QKRPP4_5x60Zn	Screw- Schraube- Vis- Vite- Tornillo- 4.5x60mm 	100		
QKRYP5x60Zn	Screw- Schraube- Vis- Vite- Tornillo- 5x60mm ZnY 	32		
QKRPP5x80ZnTX	Screw- Schraube- Vis- Vite- Tornillo- 5x80mm 	140		
QKRP_P6x120ZnTX	Screw- Schraube- Vis- Vite- Tornillo- 6x120mm TX 	4		
QKRYP8x100Zn	Screw- Schraube- Vis- Vite- Tornillo- 8x100mm ZnY 	6		
QKRYP8x260Zn	Screw- Schraube- Vis- Vite- Tornillo- 8x260mm ZnY 	4		
A51-10-7016	Window - Fenster - Fenetre - Finestra-Ventana 2720x390 	2		



45x45 lath under roof overhang on the FRONT wall

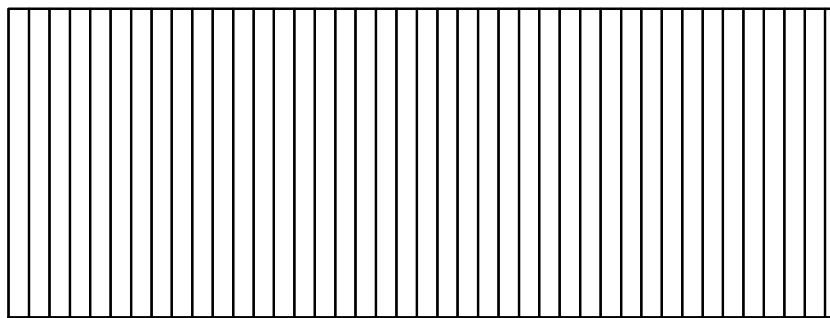
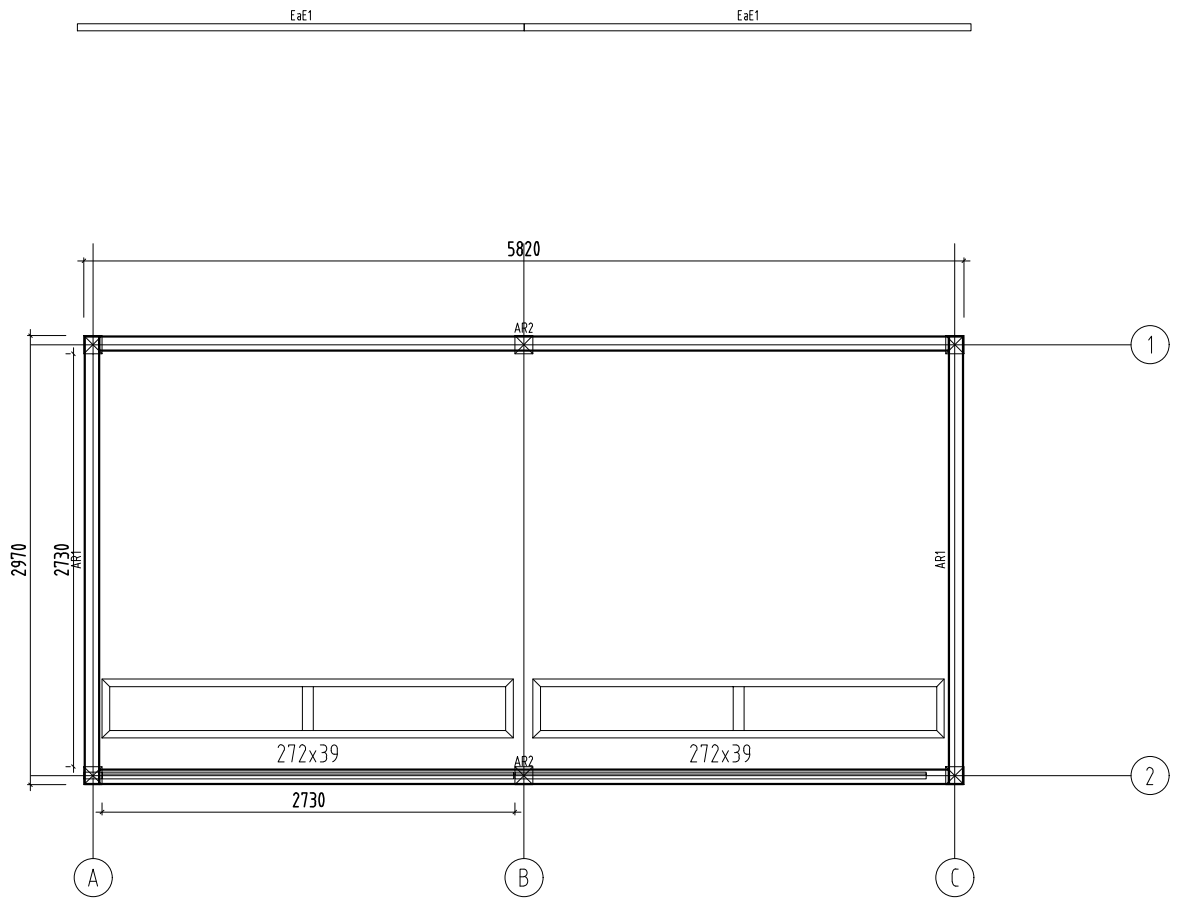

Wall panelling- Wandverkleidung- Revetement du mur- Rivestimento di muro- Rivestimento de pared



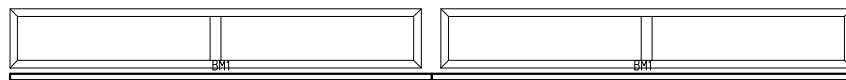
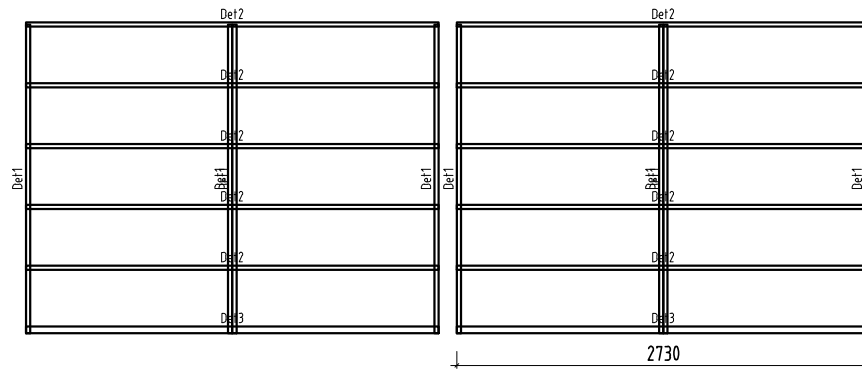
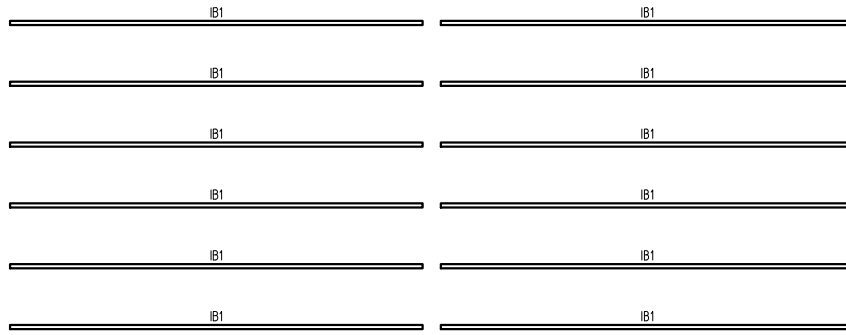

NB!

1.

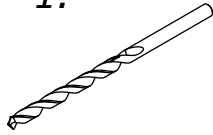

2.

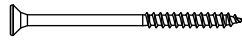

$\varnothing 1,5 \text{ mm}$	$\varnothing 3,0...4$
$\varnothing 2,0 \text{ mm}$	$\varnothing 4,5$
$\varnothing 6,0 \text{ mm}$	$\varnothing 8,0$

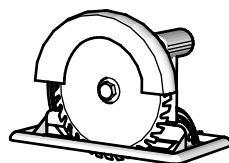
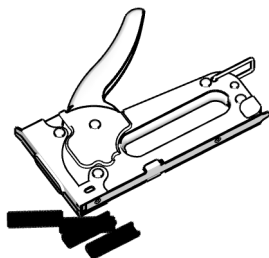
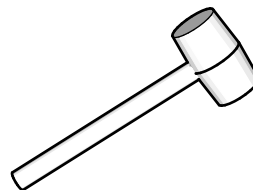
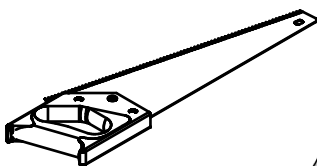
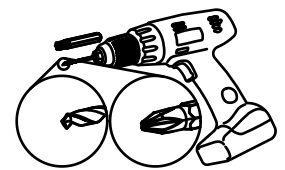
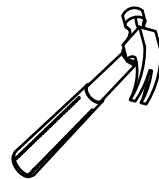
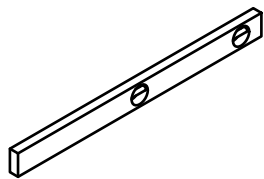
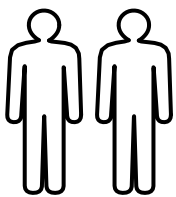
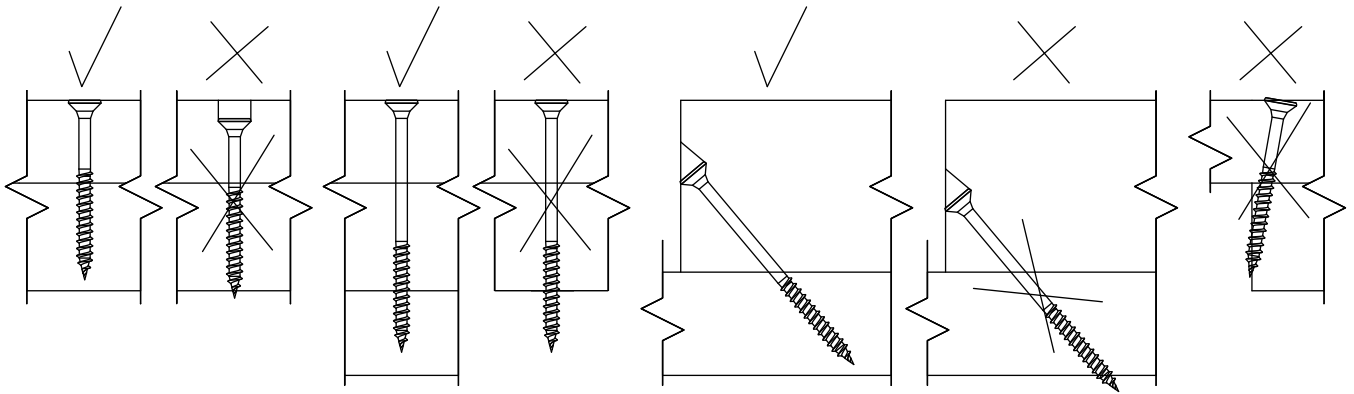

**\***

ENG	-	Not included
GER	-	Nicht enthalten
FR	-	Non inclus
ES	-	No incluso
IT	-	Non incluso
NO	-	Ikke inkludert
SWE	-	Ingår inte
FIN	-	Ei sisälly hintaan
DEN	-	Ikke inkluderet
NED	-	Niet inbegrepen
POR	-	Não incluído
CZ	-	Není zahrnuto
POL	-	Nie wliczone
LIT	-	Neįtraukta
LAT	-	Nav iekļauts
RUS	-	Не включено
EST	-	Ei sisaldu komplektis

**\*\***

ENG	-	Separate manual
GER	-	Separates Handbuch
FR	-	Manuel séparé
ES	-	Manual separado
IT	-	Manuale separato
NO	-	Separat manual
SWE	-	Separat manual
FIN	-	Erillinen käyttöohje
DEN	-	Separat manual
NED	-	Aparte handleiding
POR	-	Manual separado
CZ	-	Samostatný manuál
POL	-	Osobna instrukcja
LIT	-	Atskiras vadovas
LAT	-	Atsevišķa rokasgrāmata
RUS	-	Отдельное руководство
EST	-	Eraldi juhend

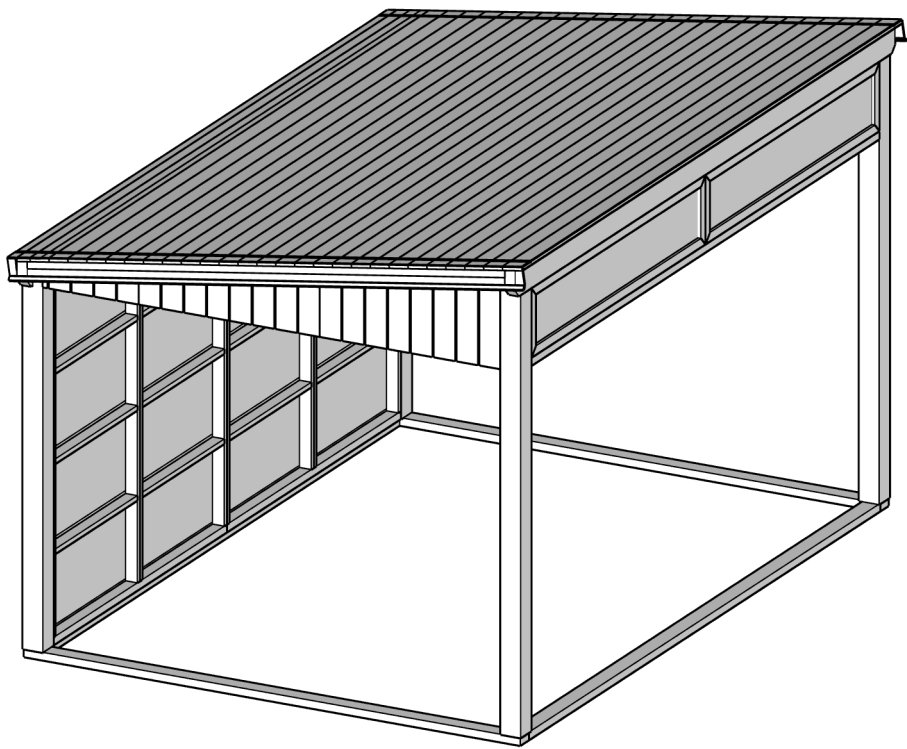
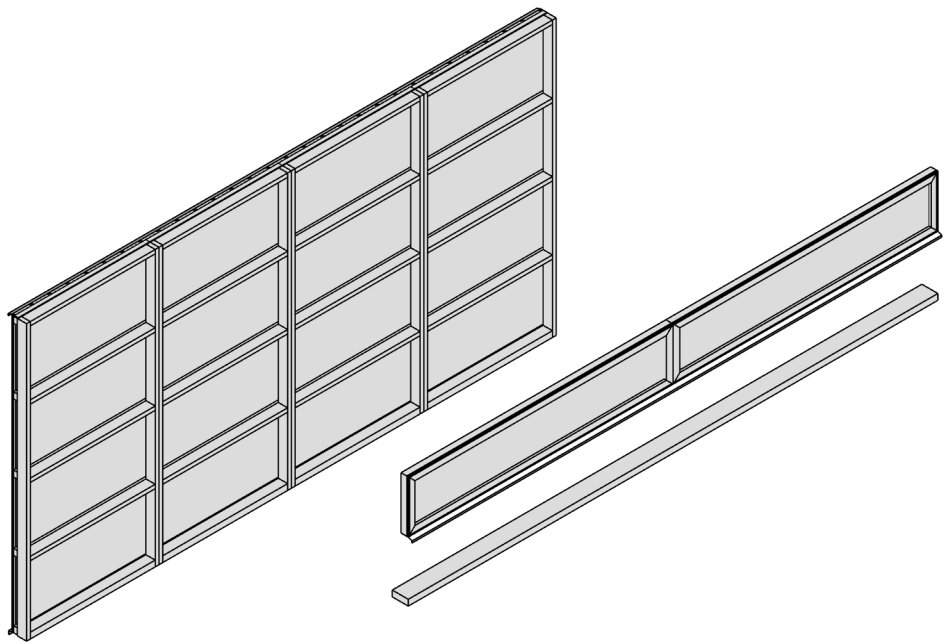

Pst1 x1

Ø8x100 x4

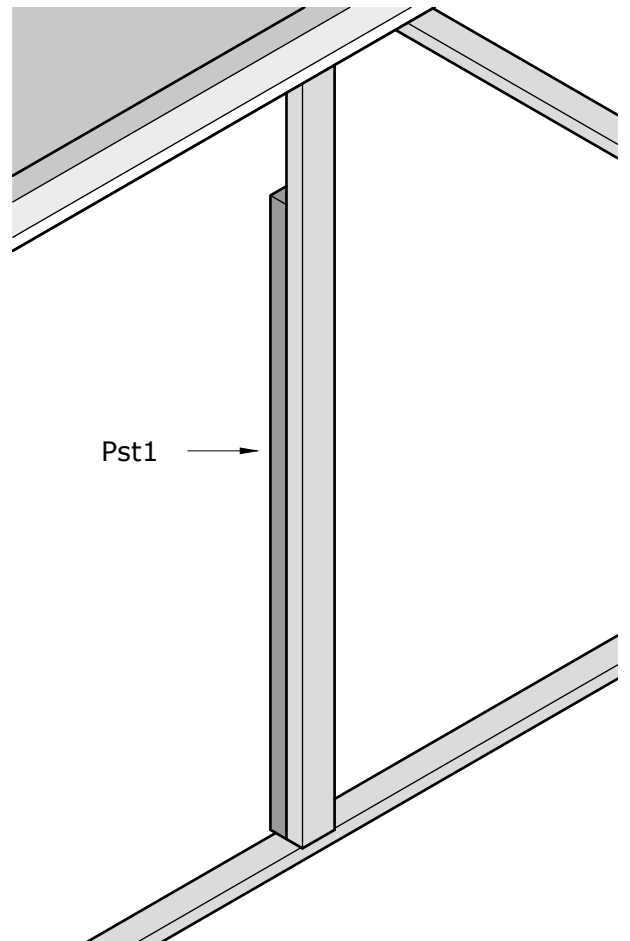
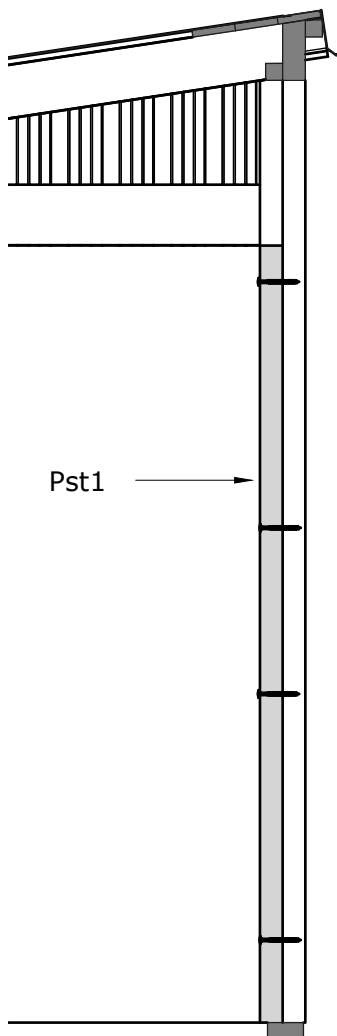
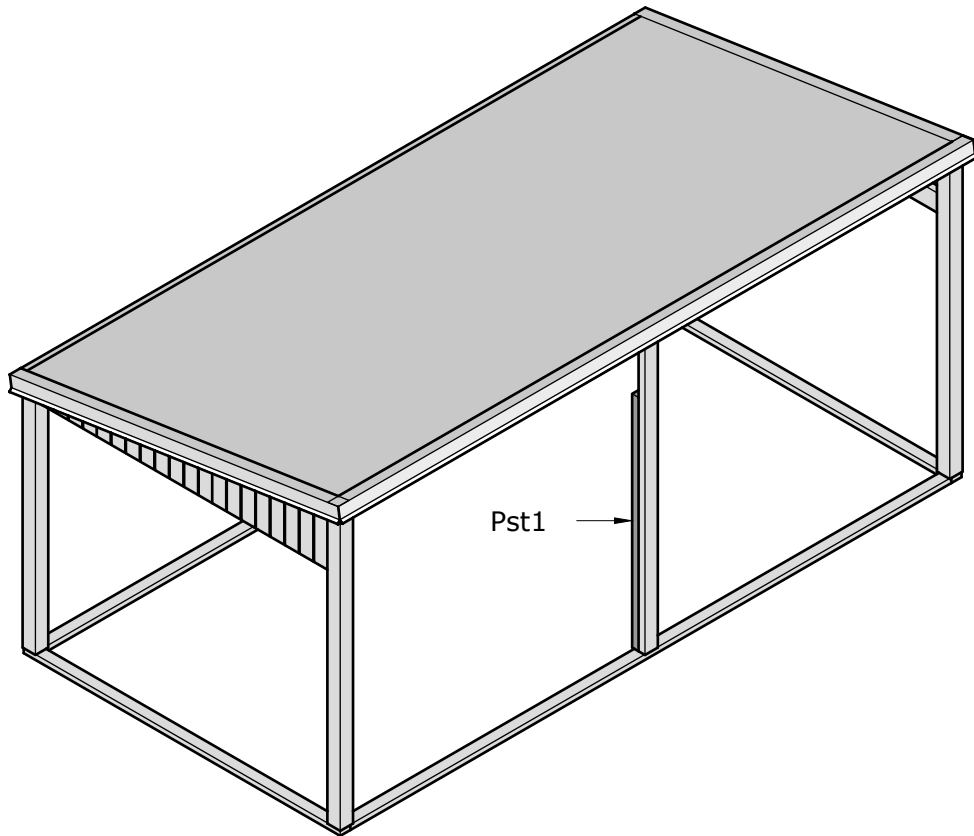
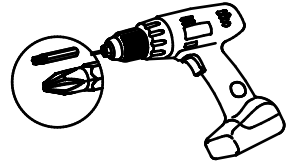
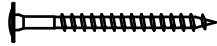

BM1 x2

Ø8x260 x4

Ø6x120 x4

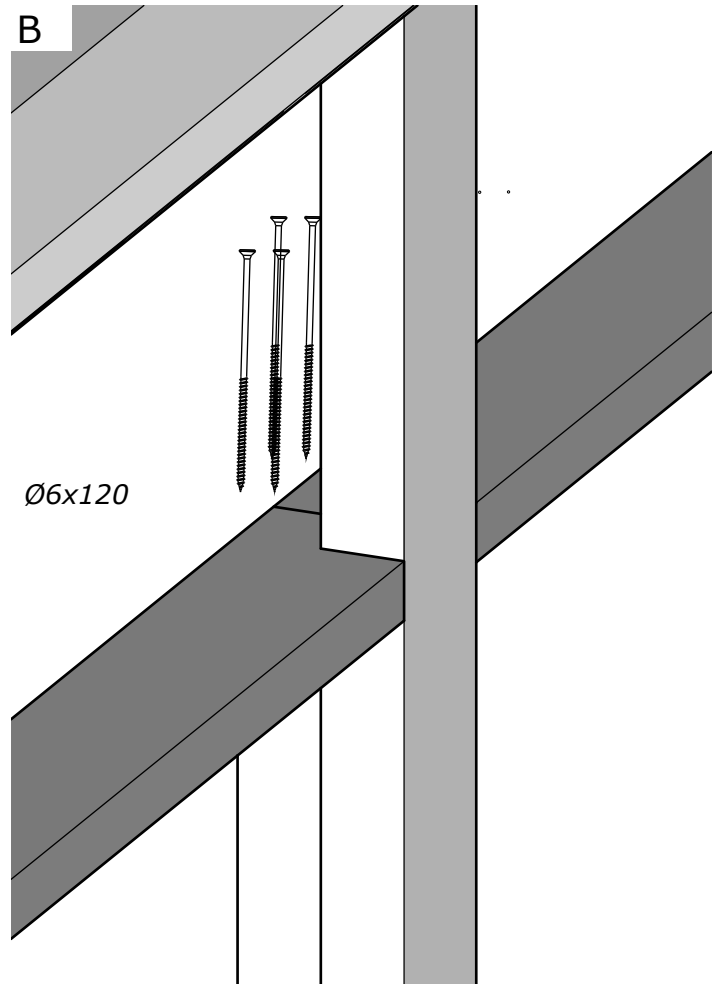
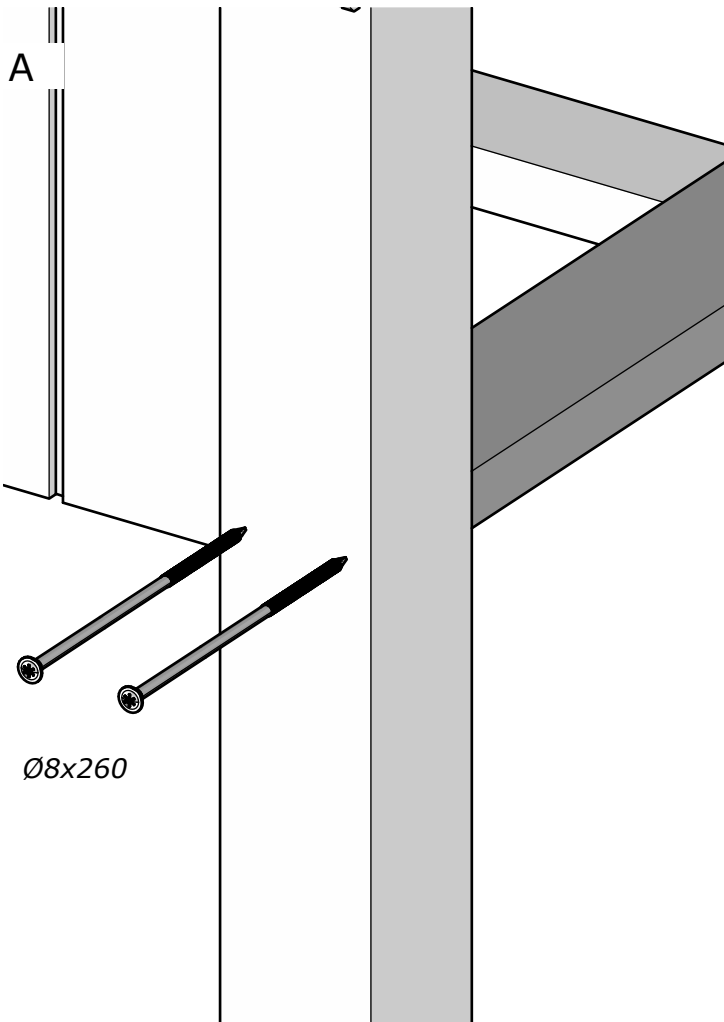
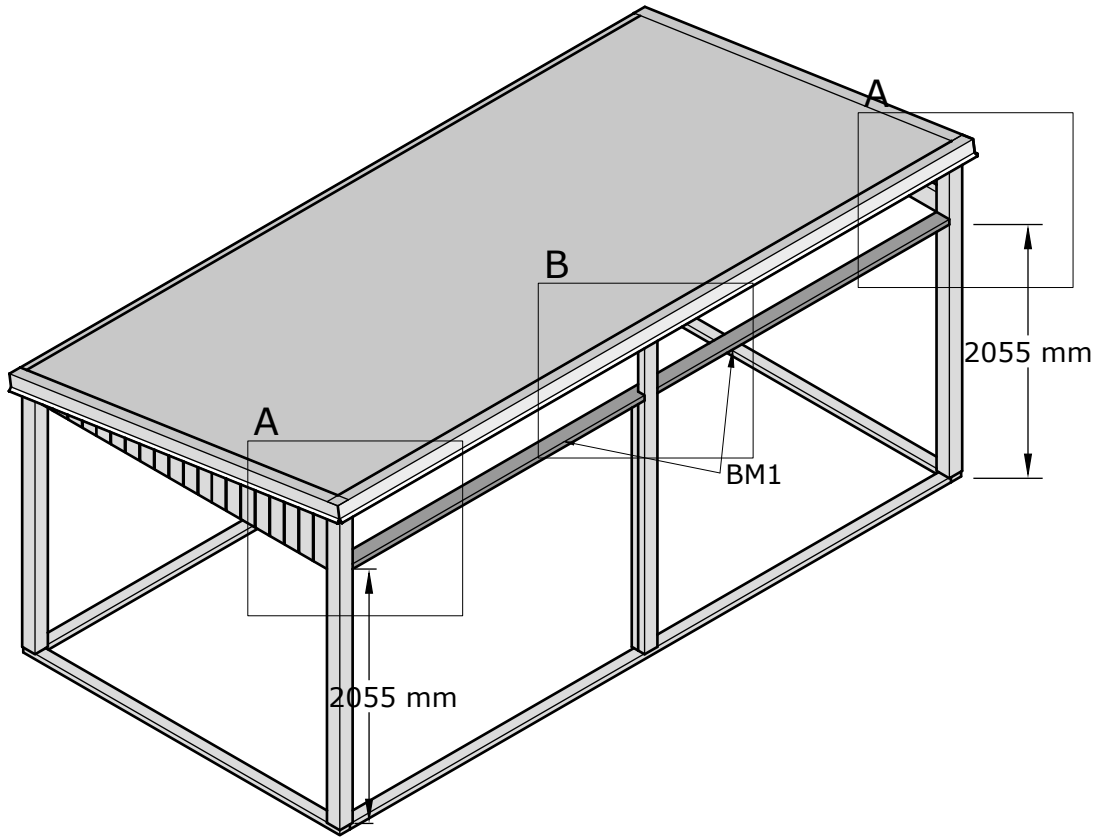
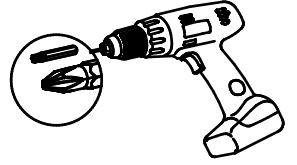
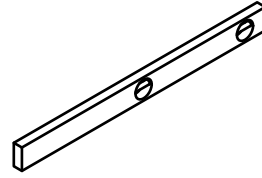
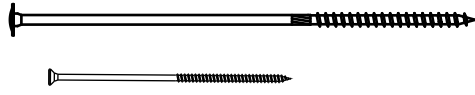

PST2 x1

Ø8x100 x2

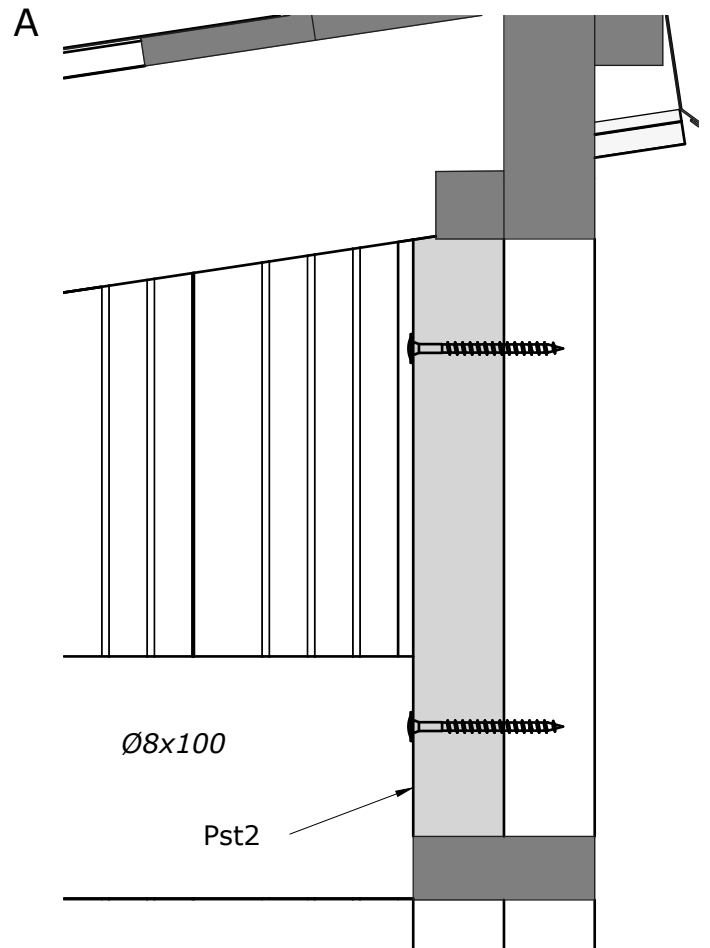
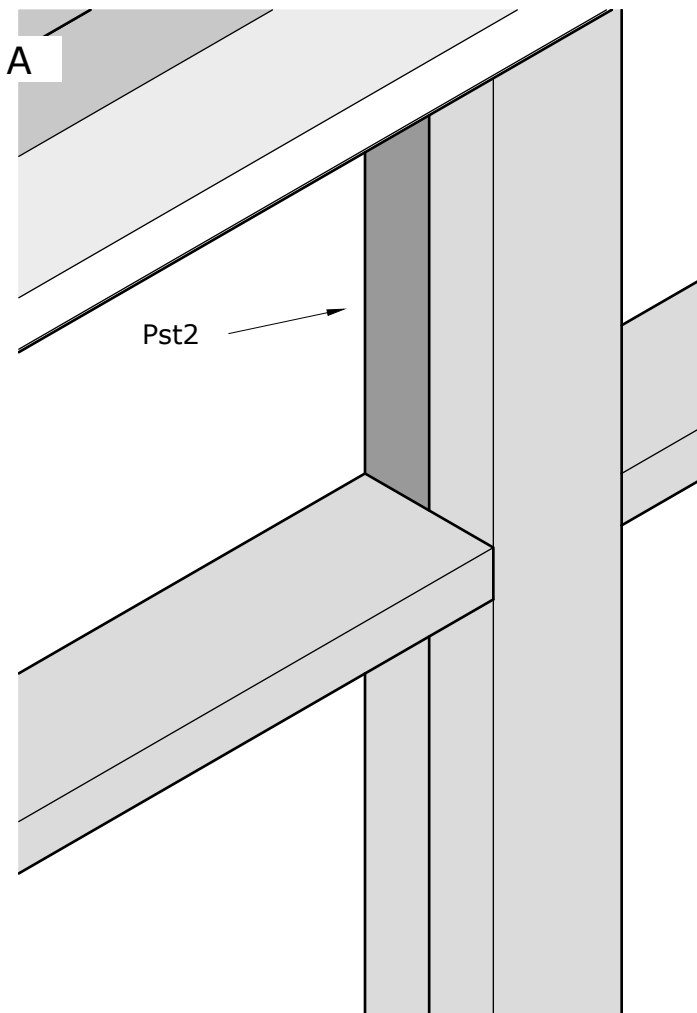
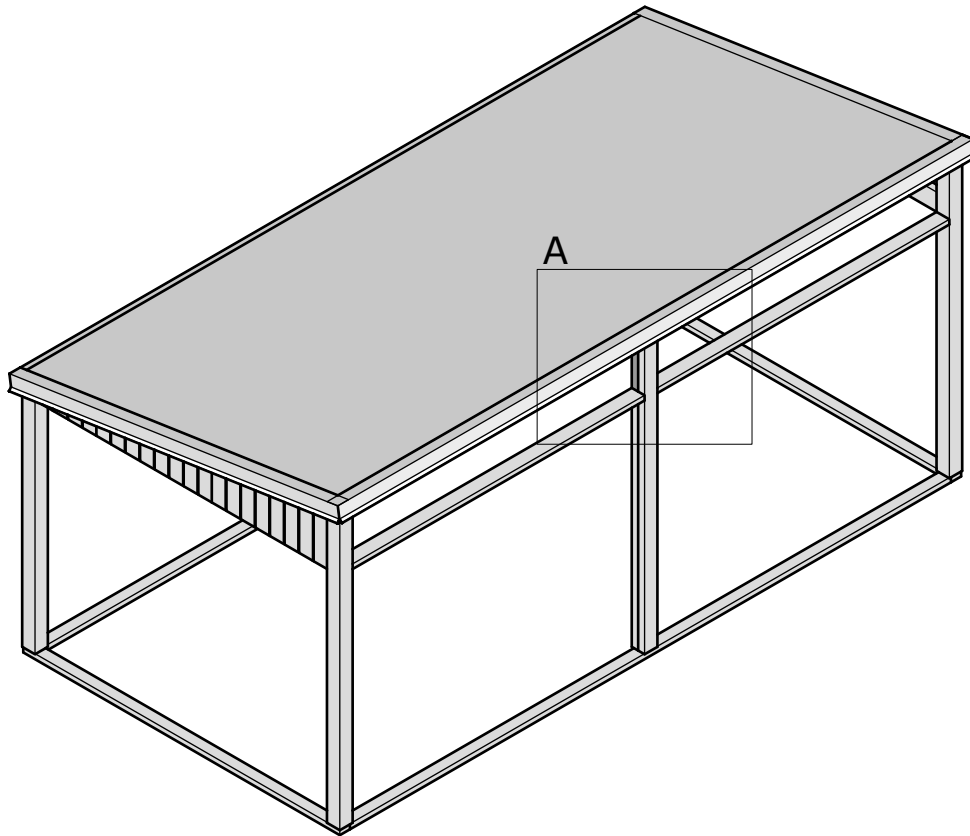
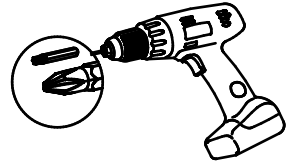
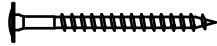

A51-10-7016

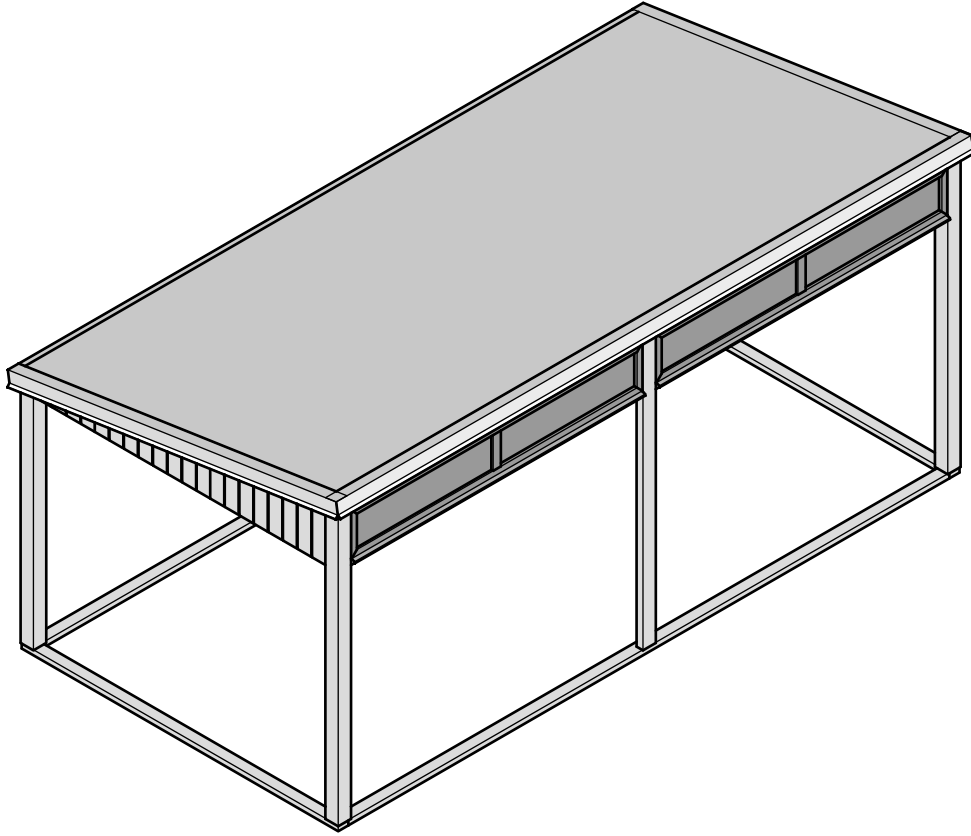

A51-10-7016

x1

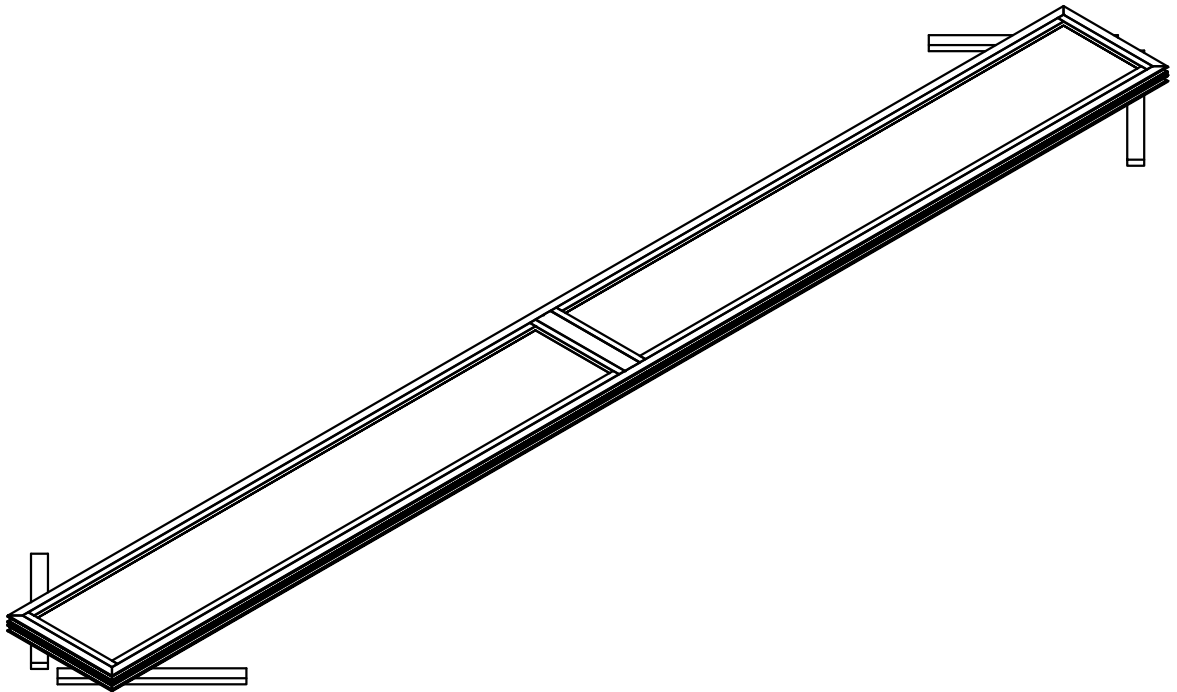

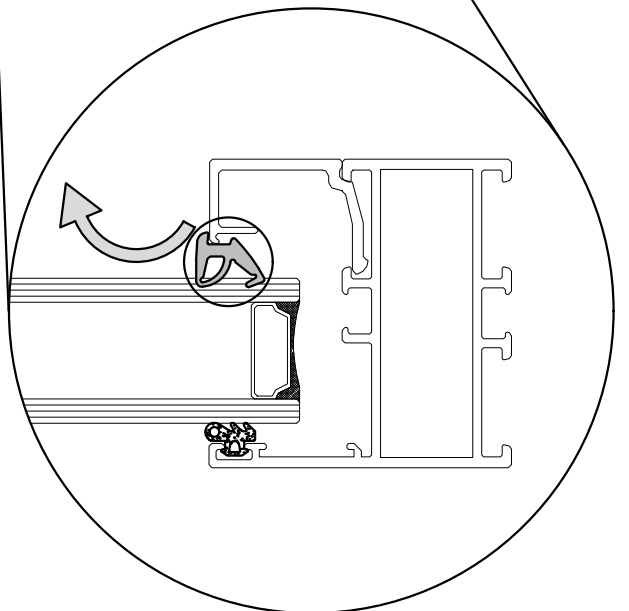
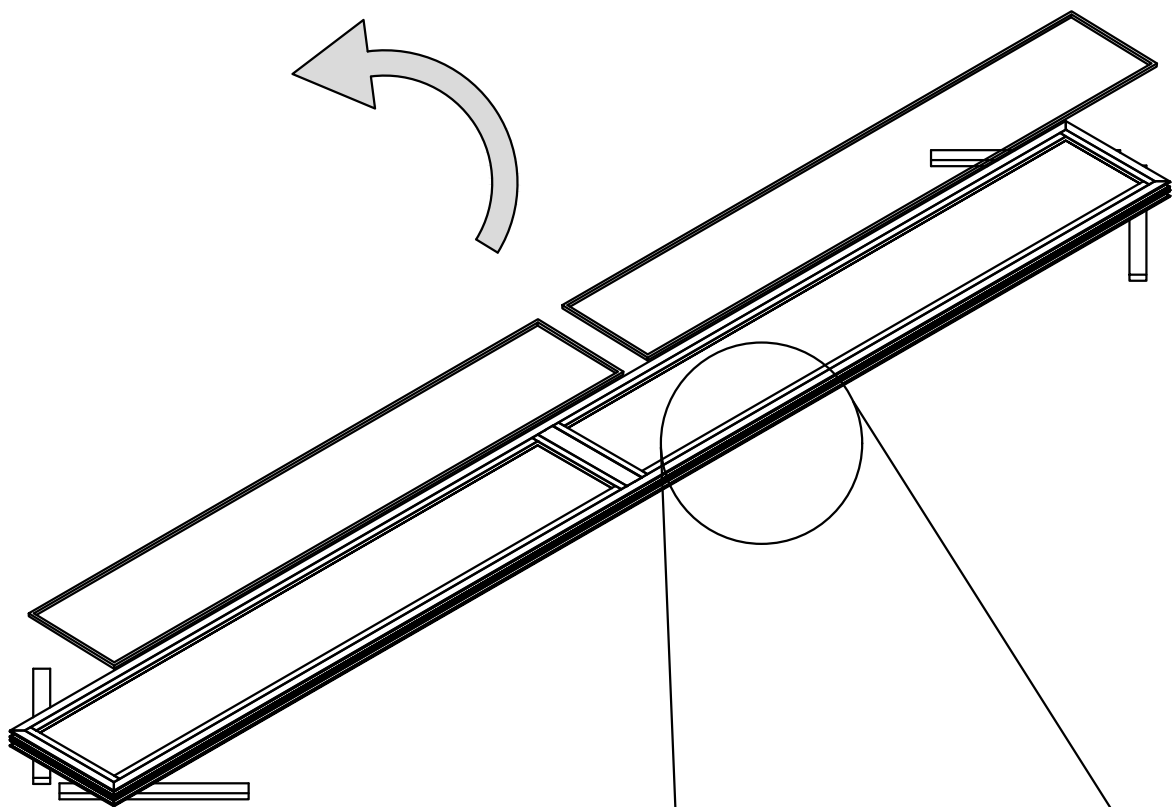

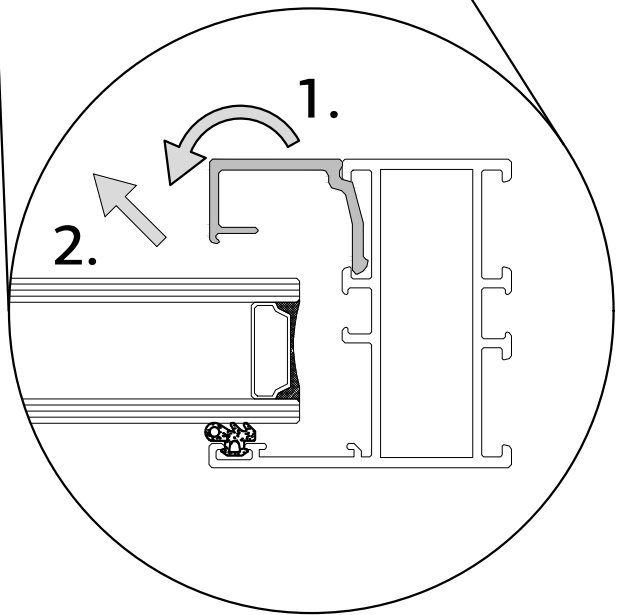
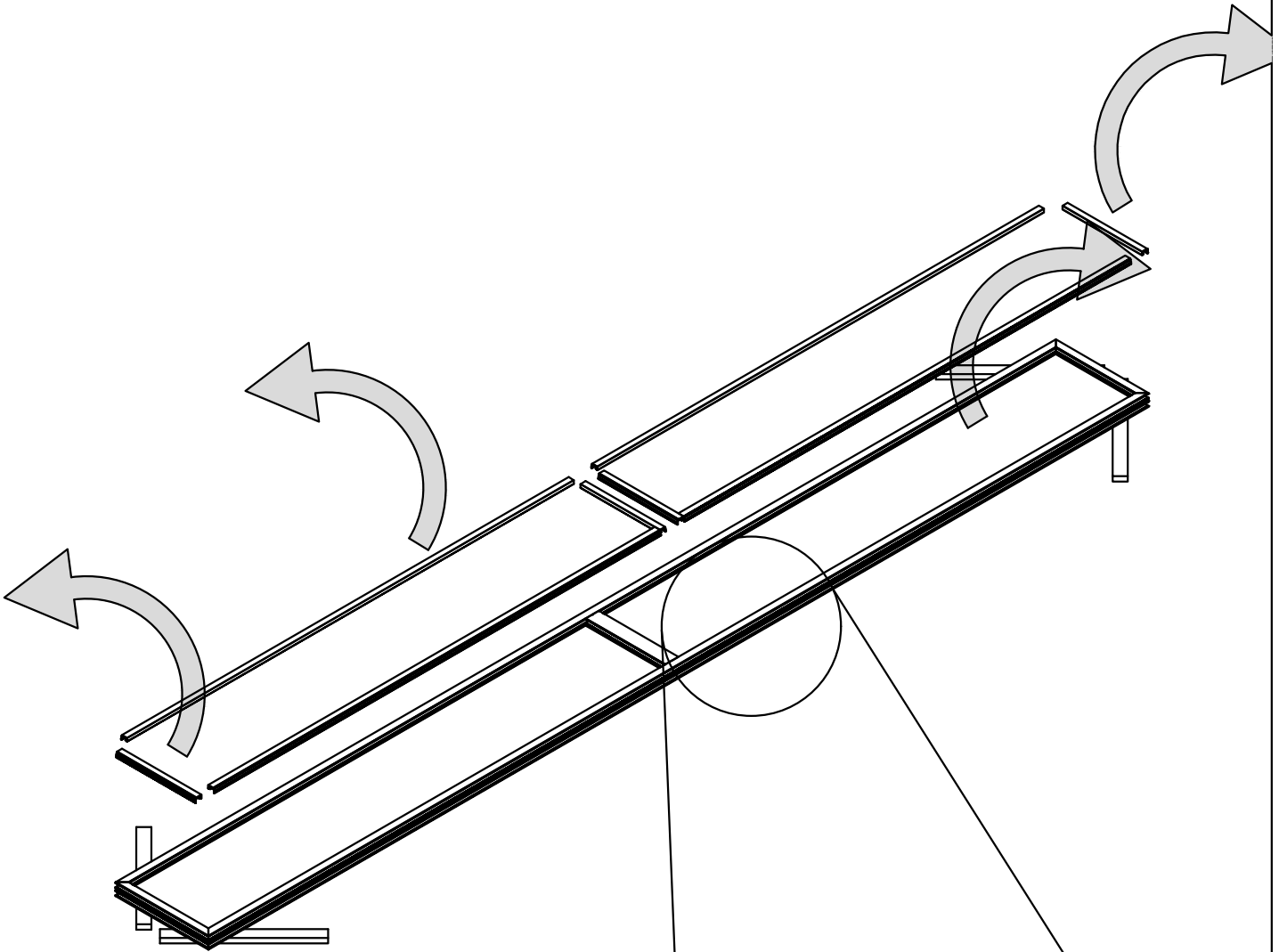

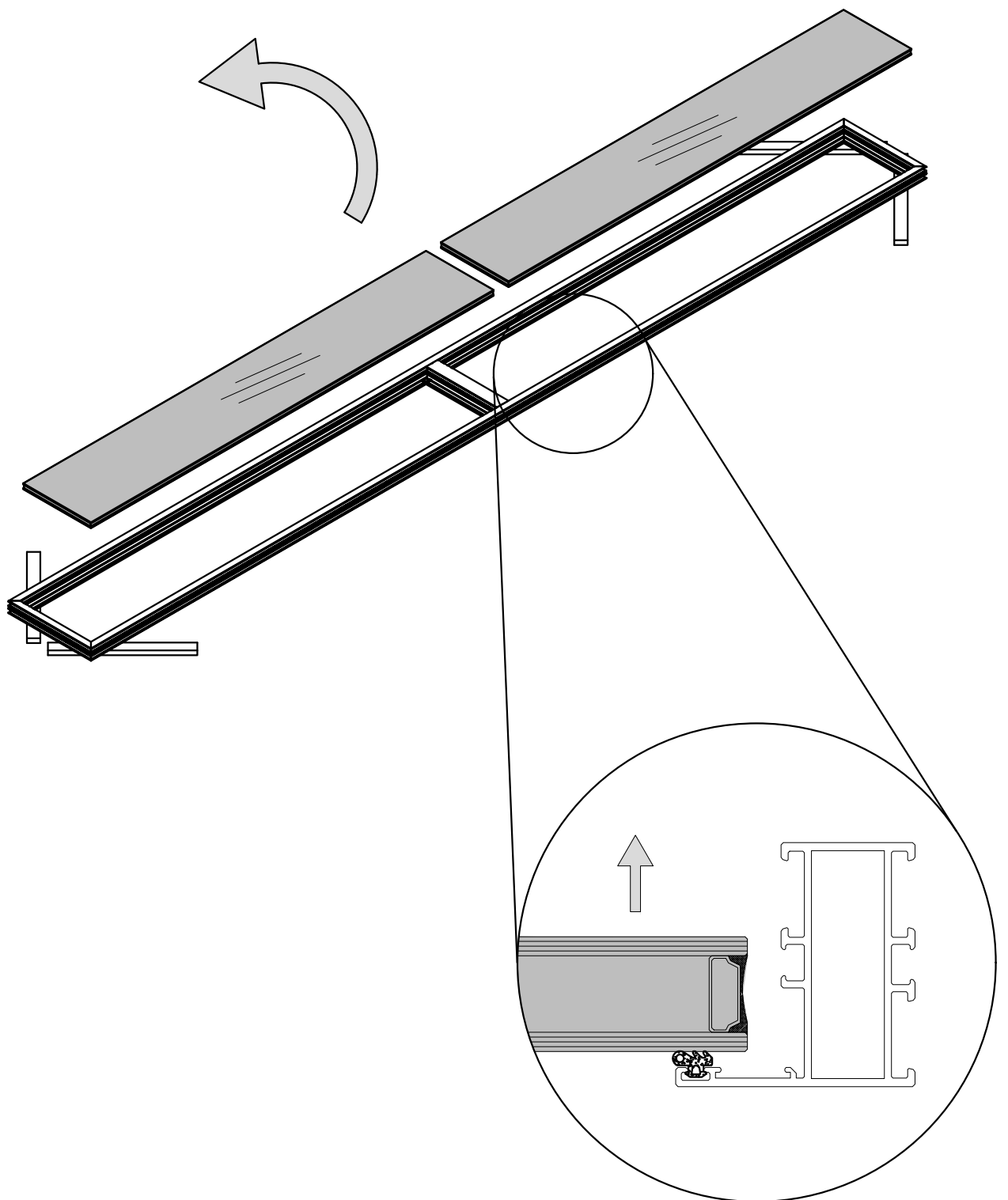

WG8



1x

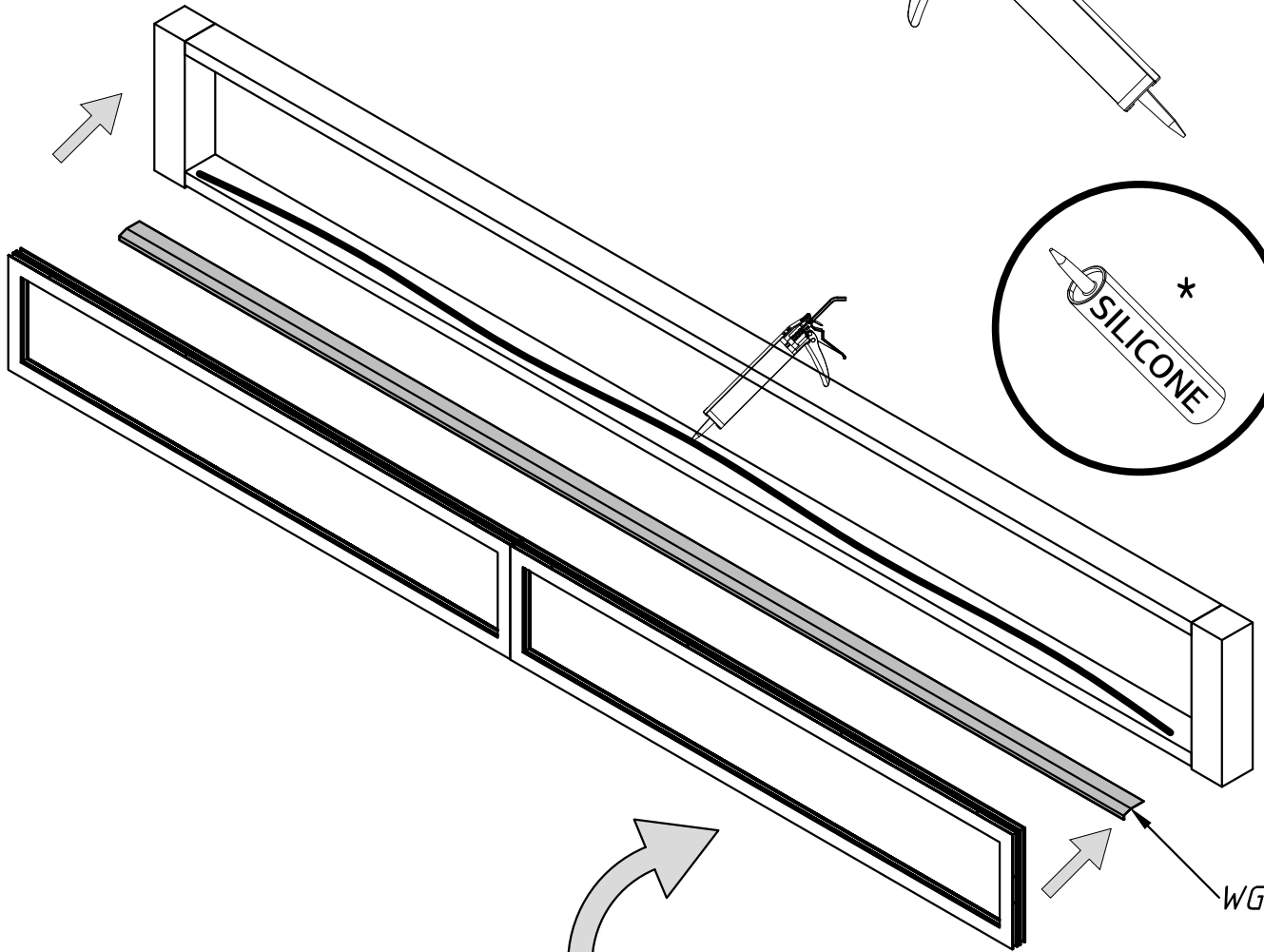
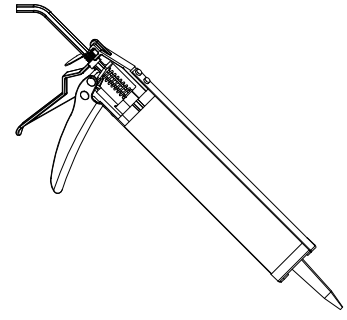

WG8

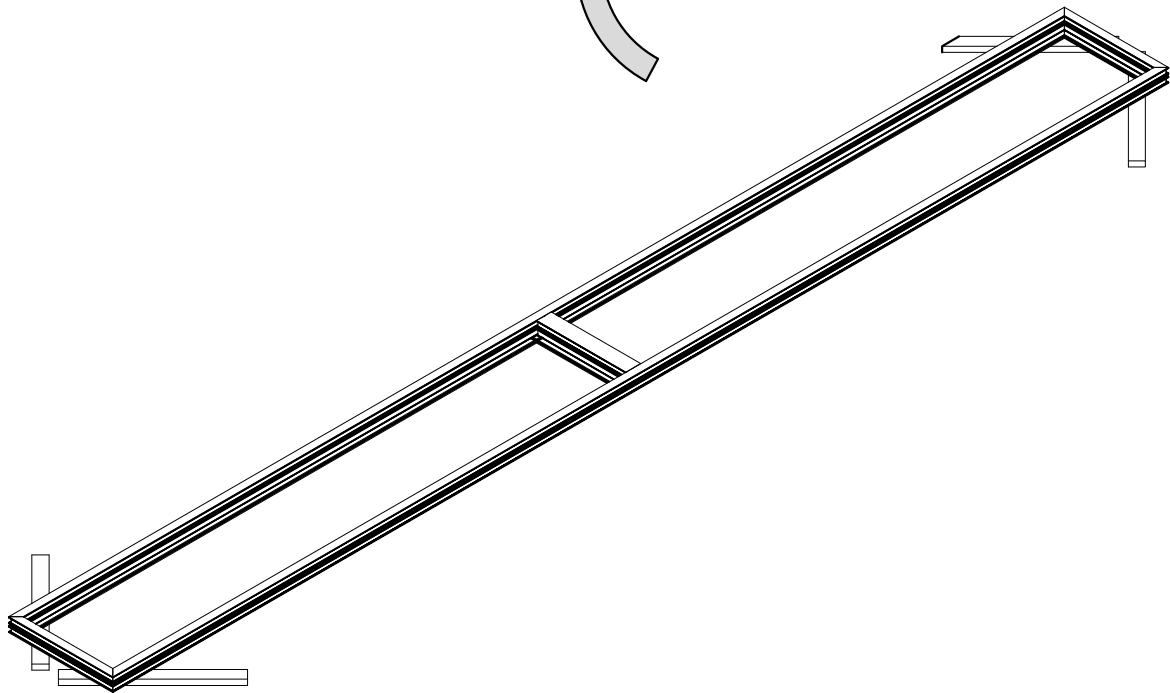
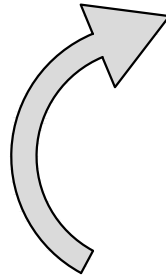

QPL20x100x2PET x16  
QPL20x100x3PET x16  
Ø5x60 x16

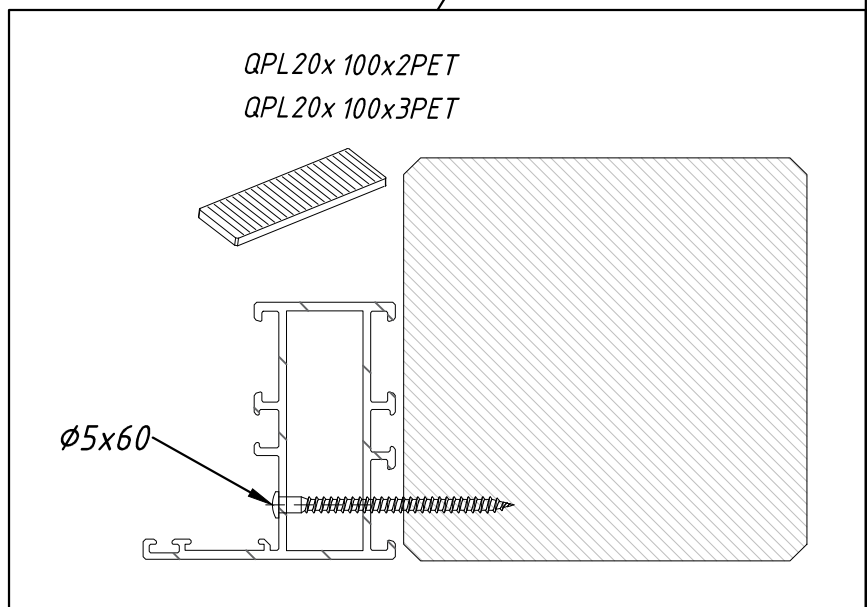
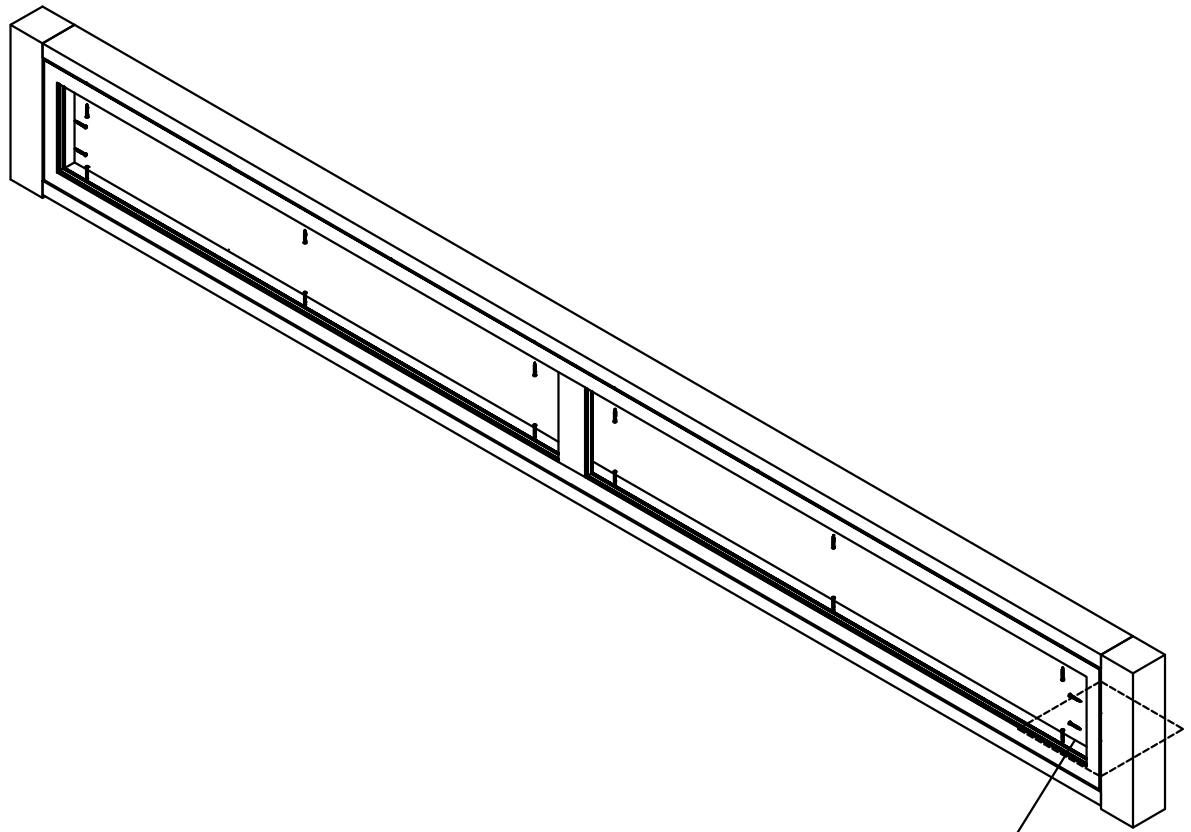
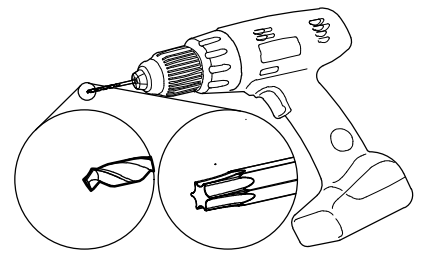
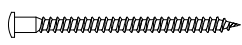
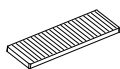
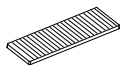

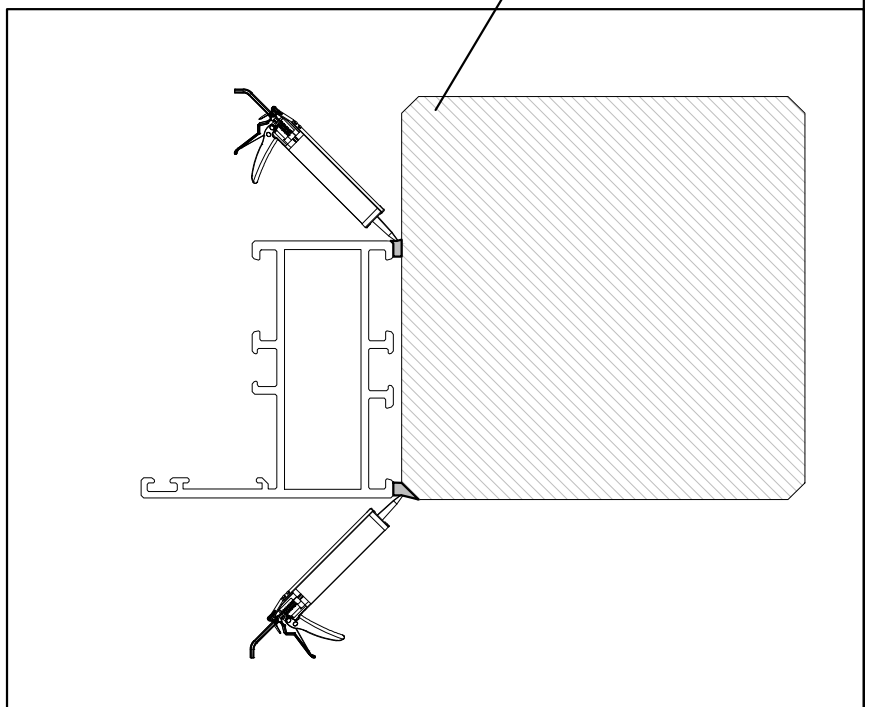
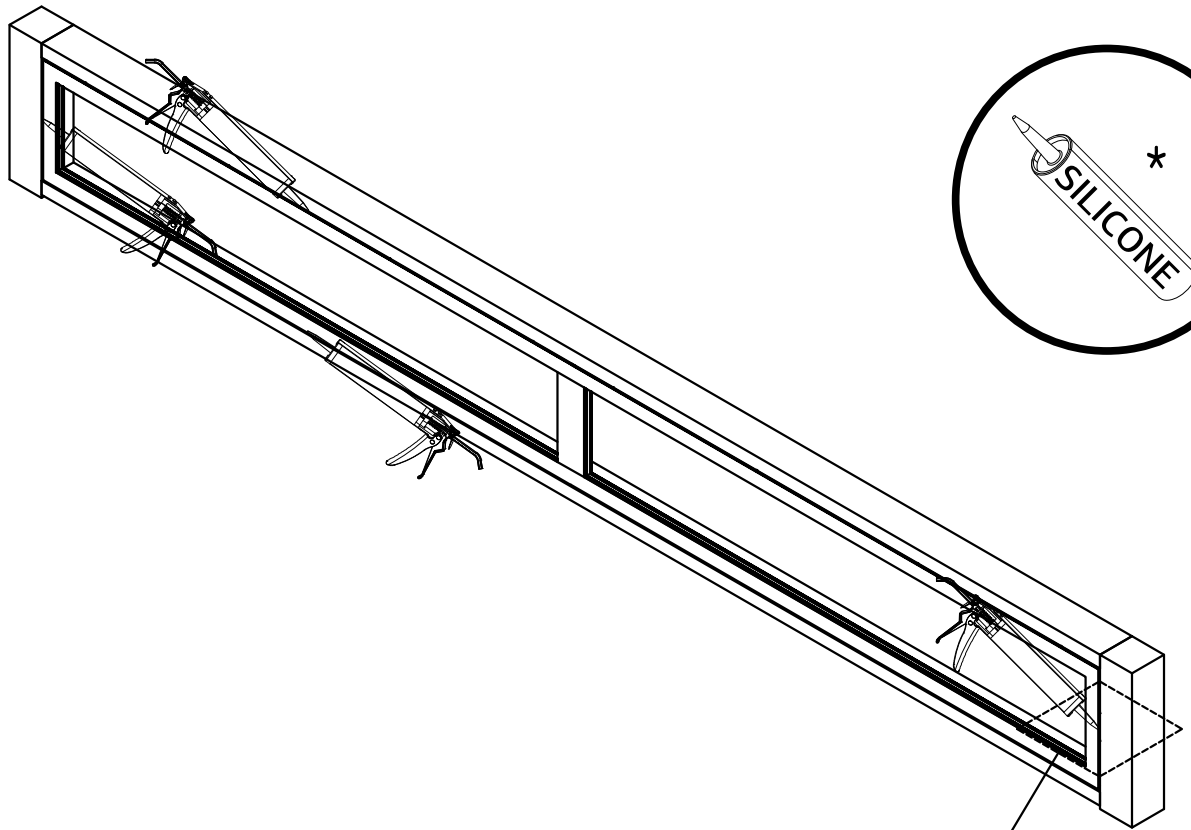
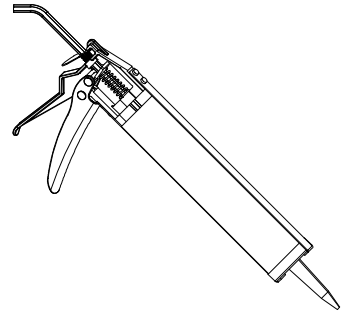

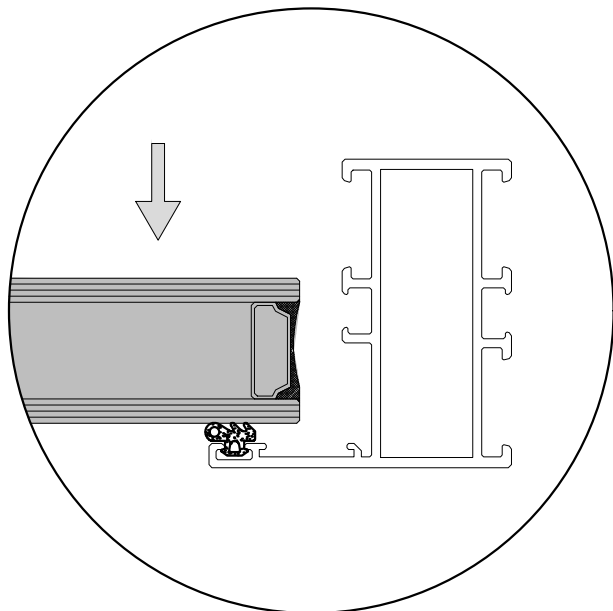
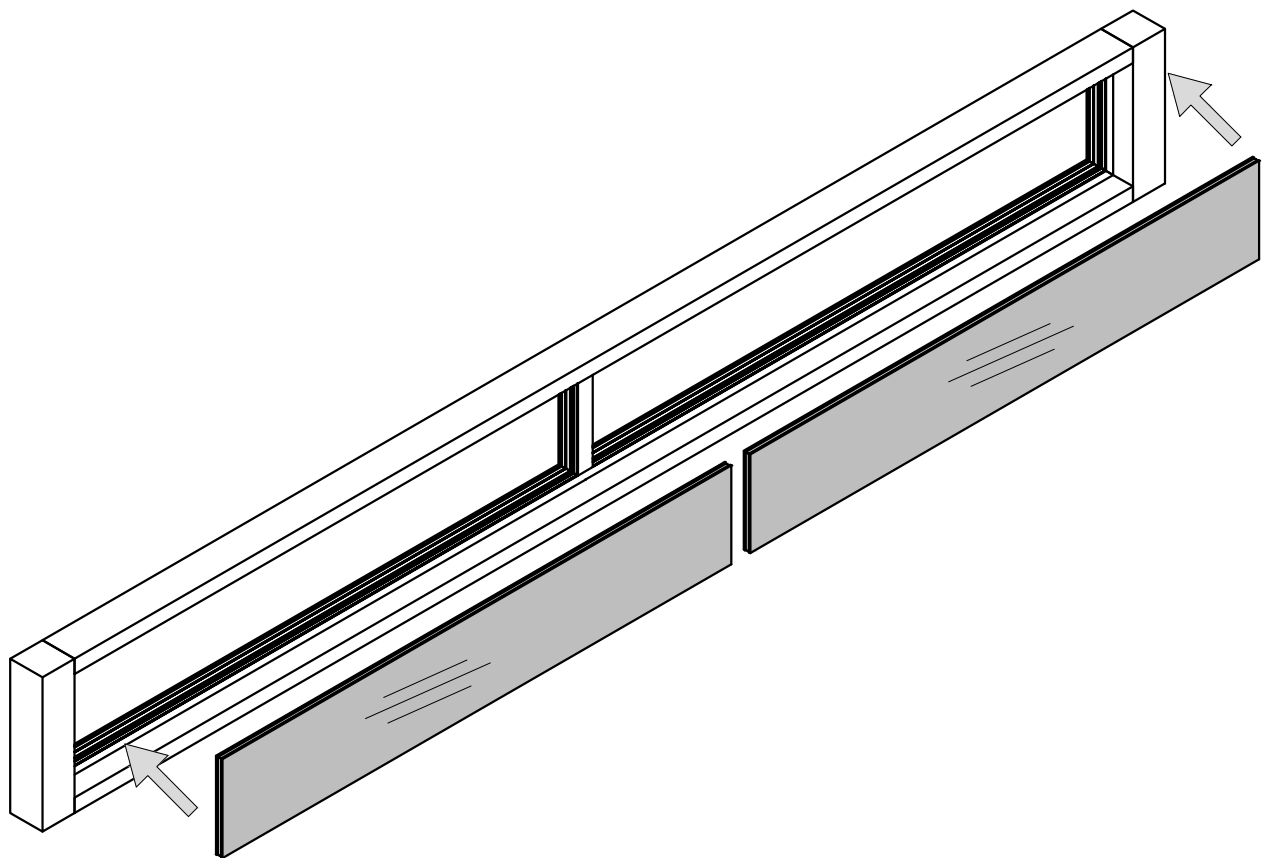

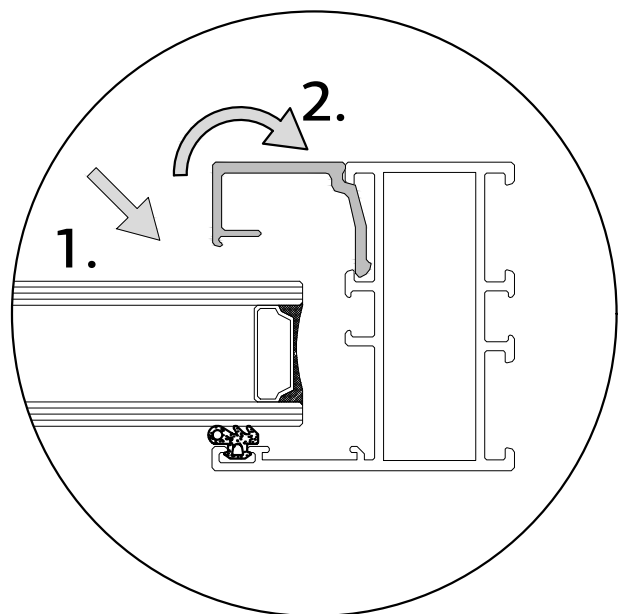
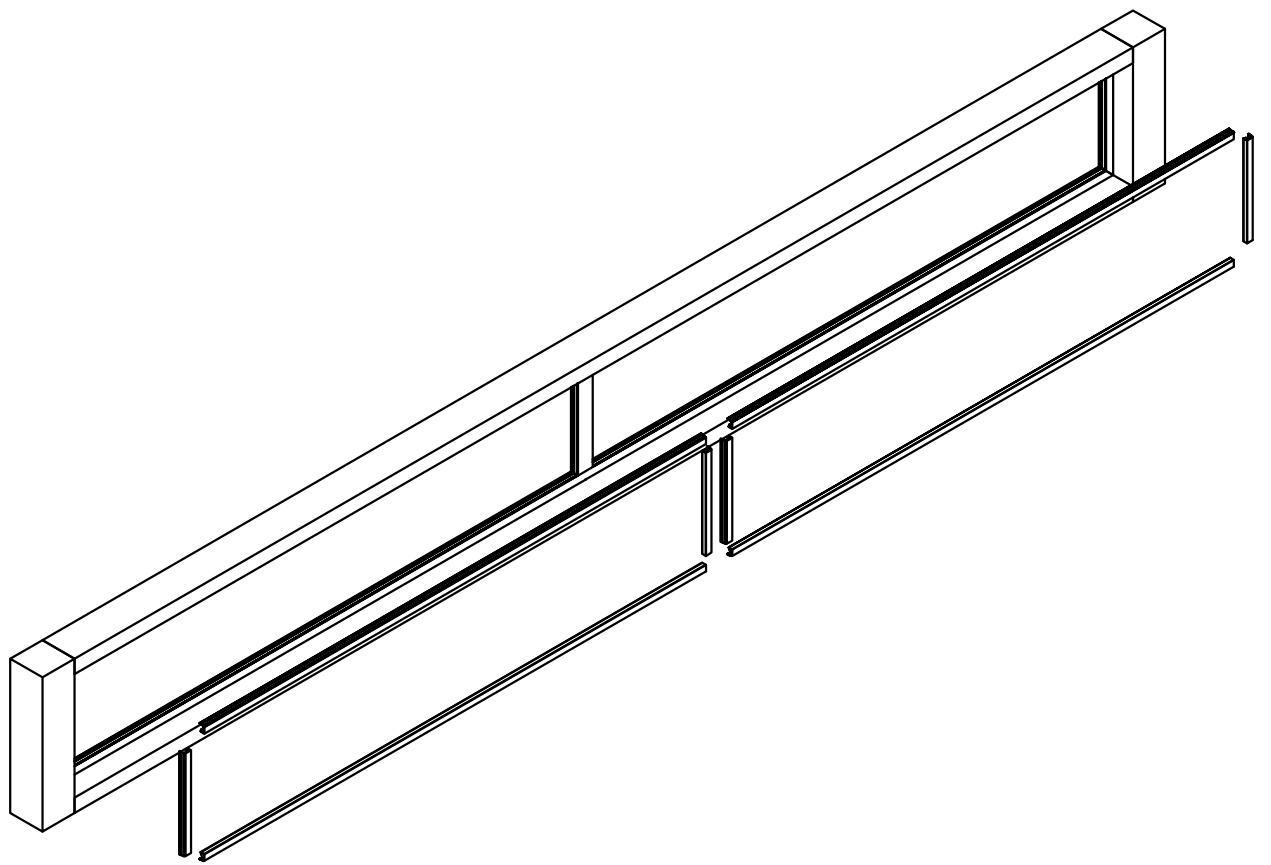

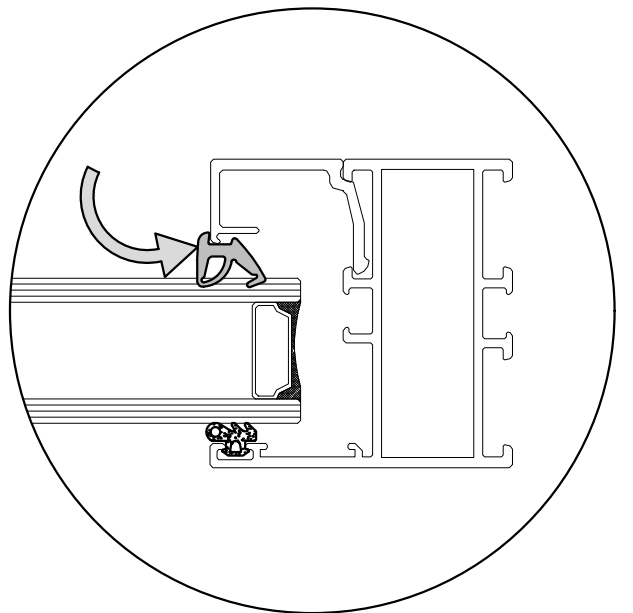
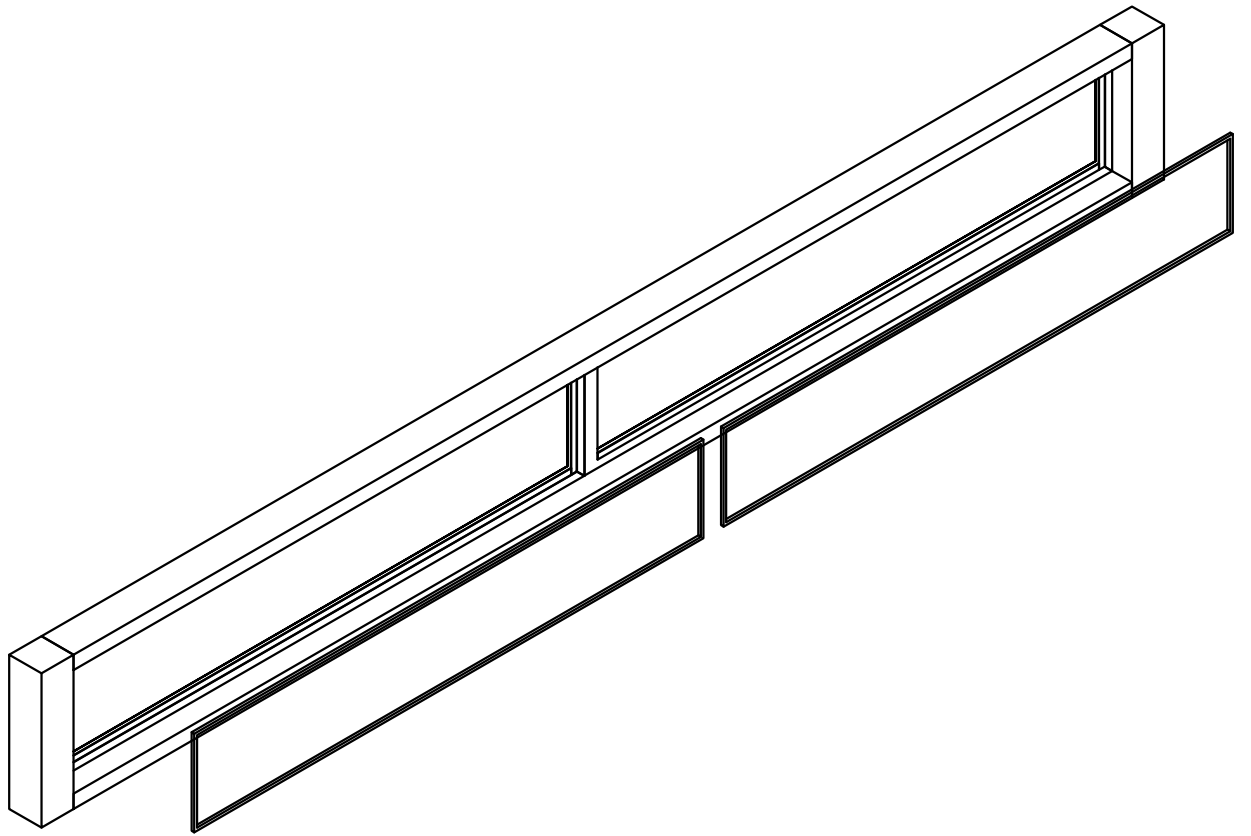



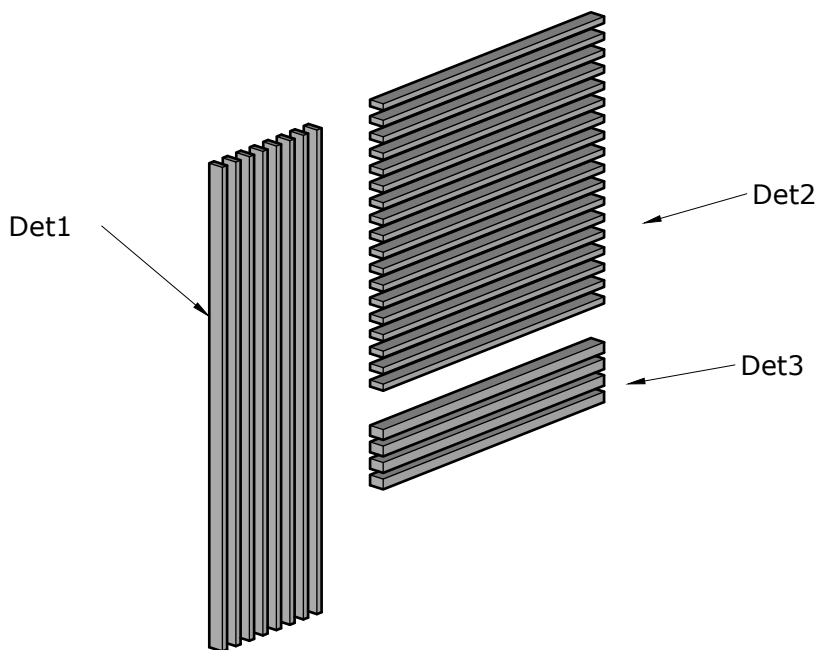
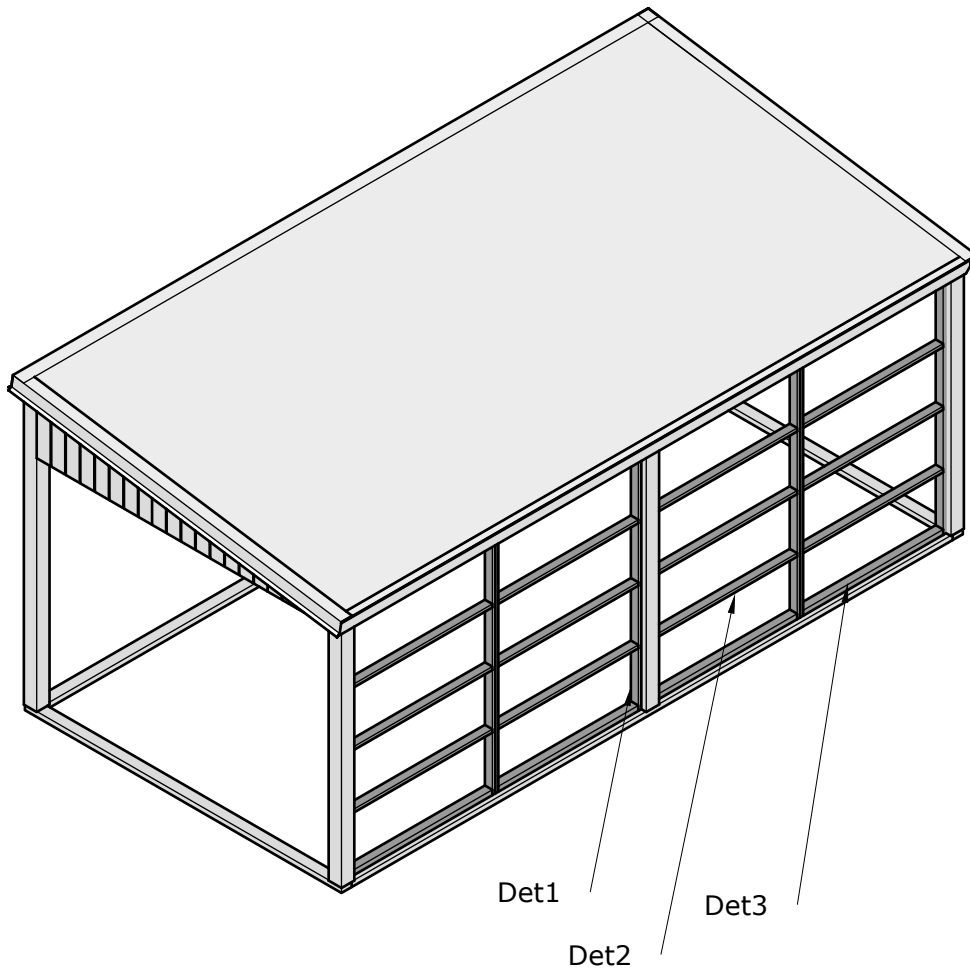

Det1 x8  
Det2 x12  
Det3 x4

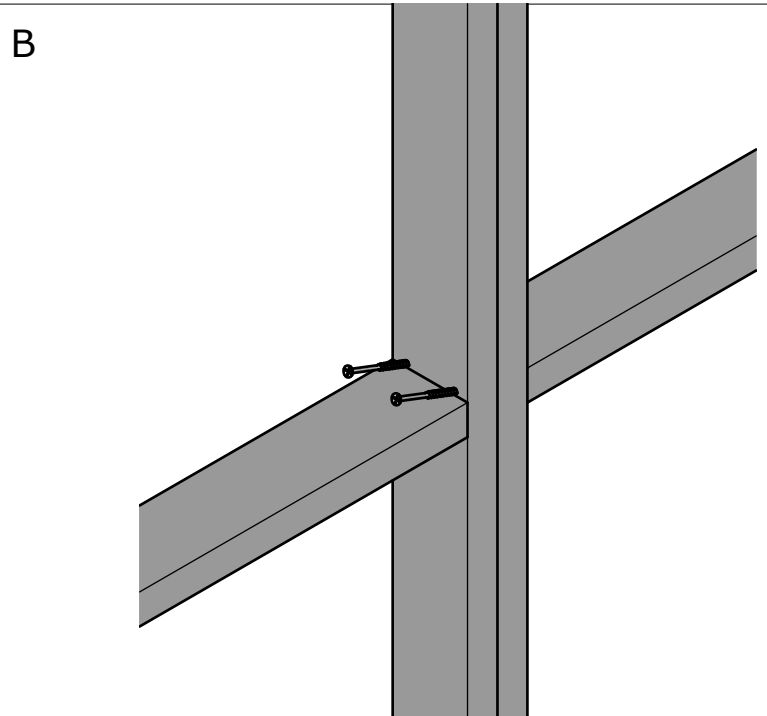
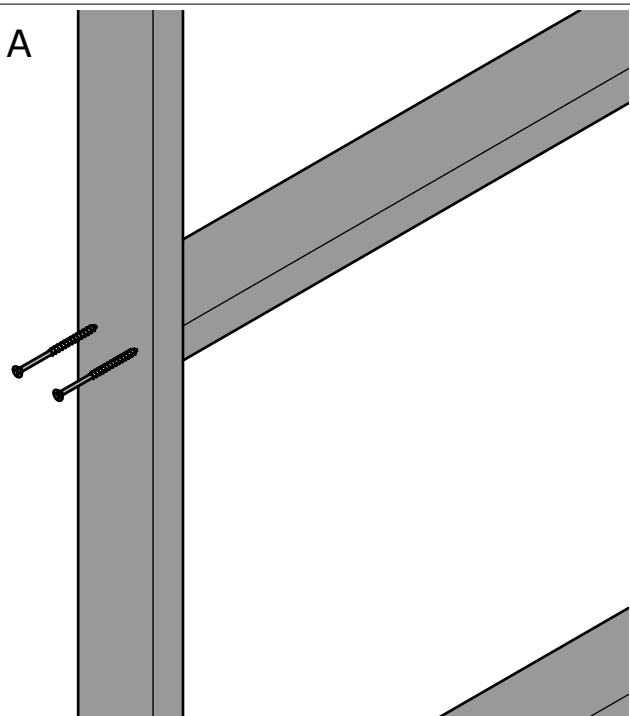
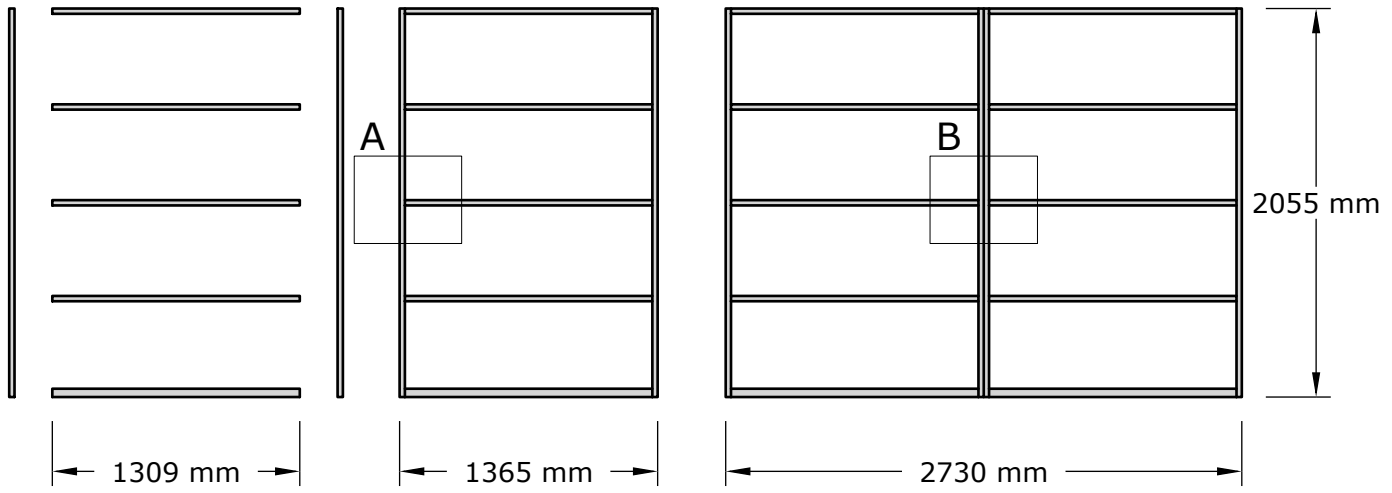
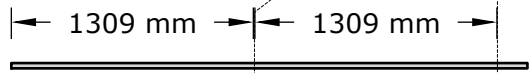
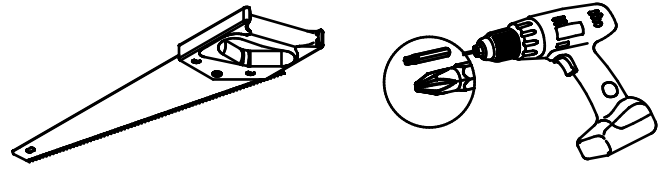

- Det1 x8
- Det2 x12
- Det3 x4

Ø5x80 x100 



Ø5x80 x40 

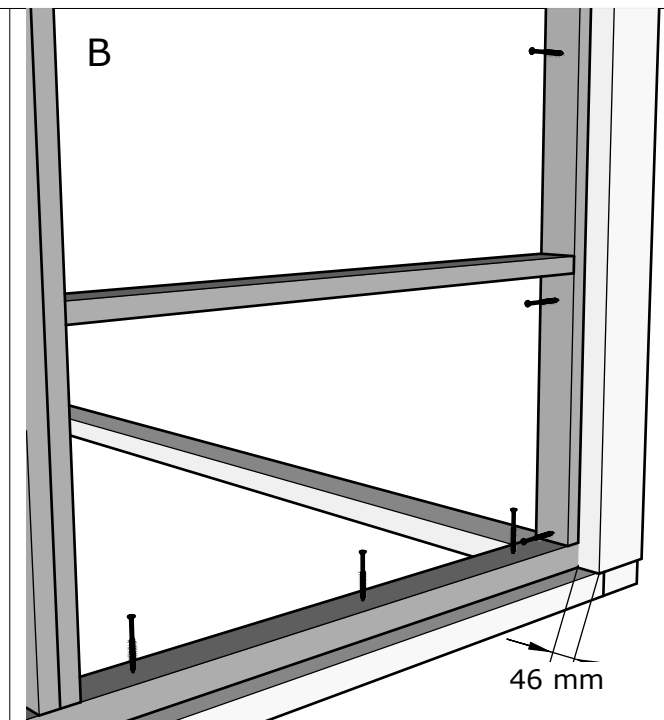
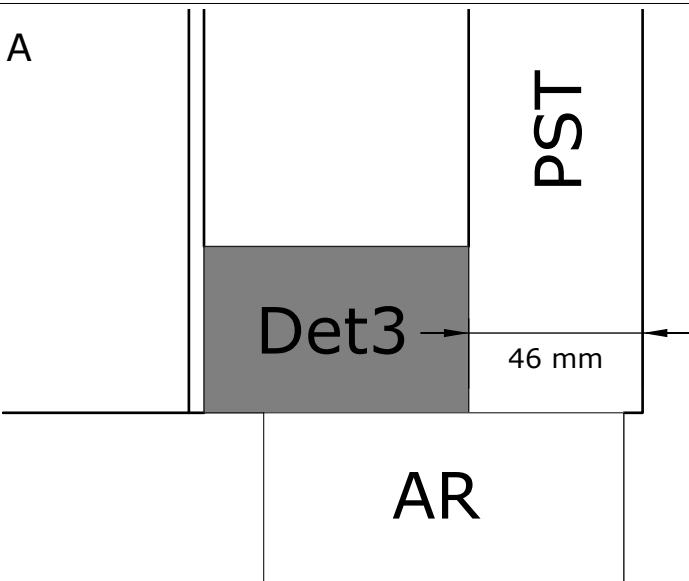
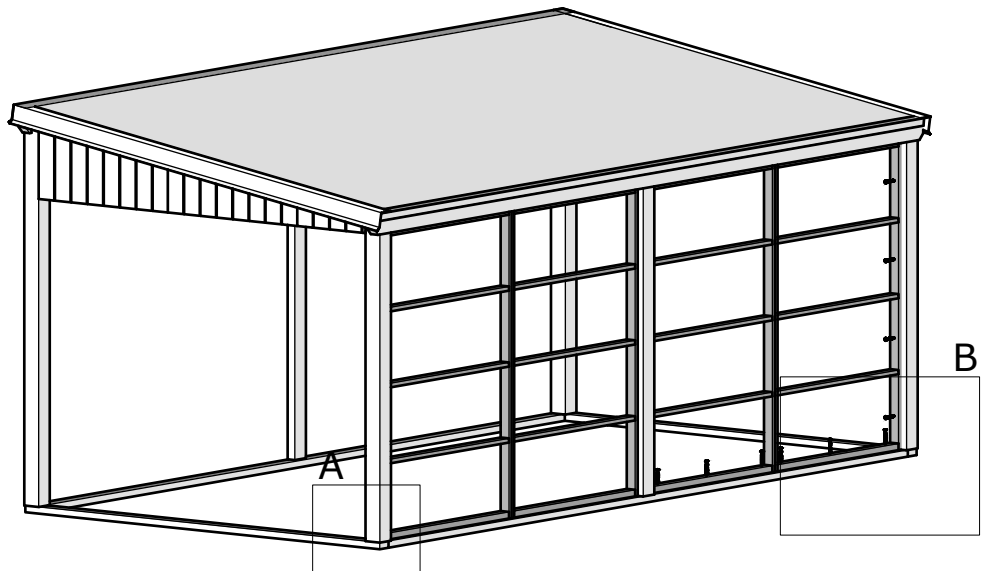
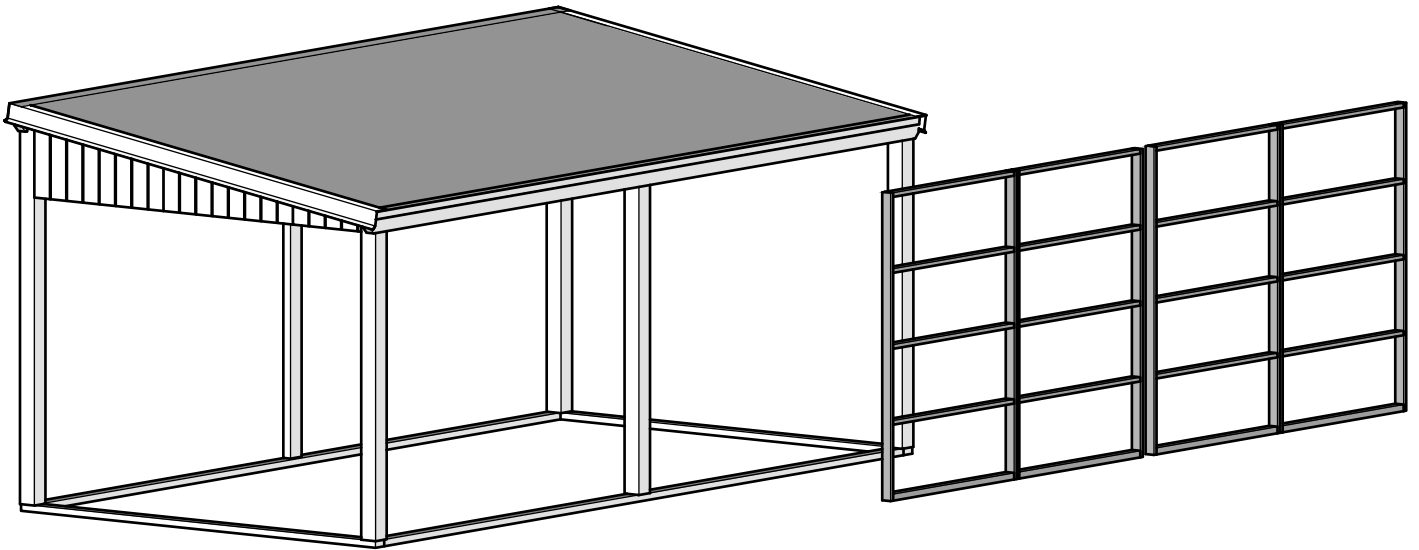
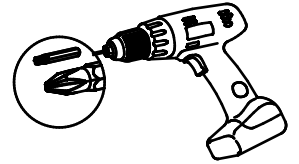

WG5-1 X2

Ø3x16 x10

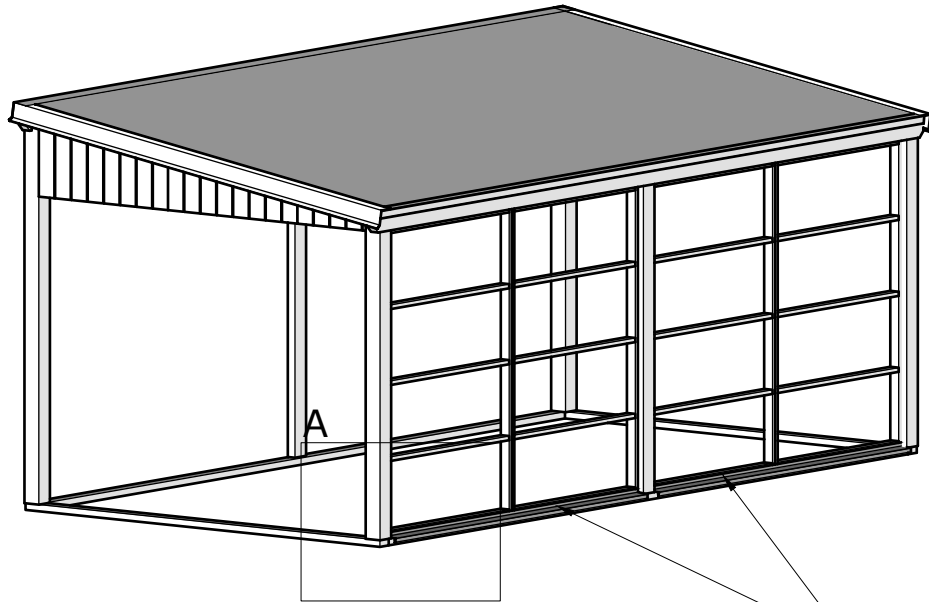
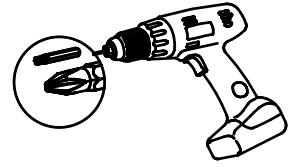

WG5-1

A

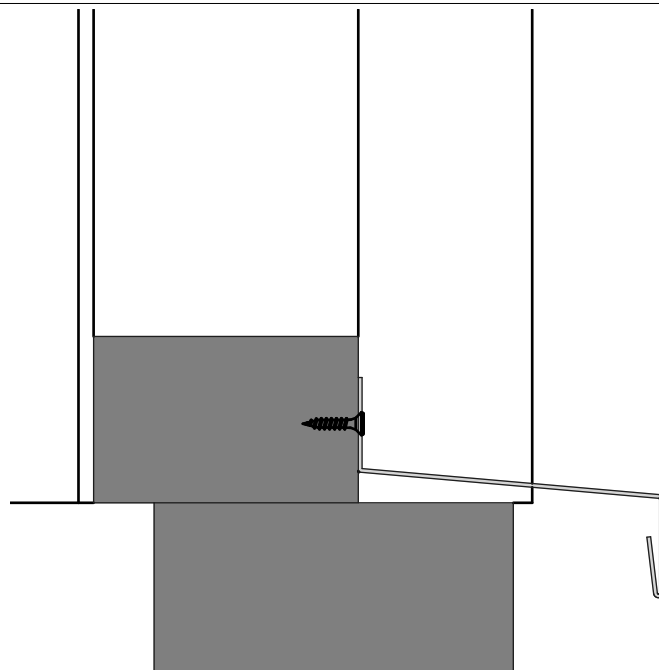

WG5-1

QKI-2-1

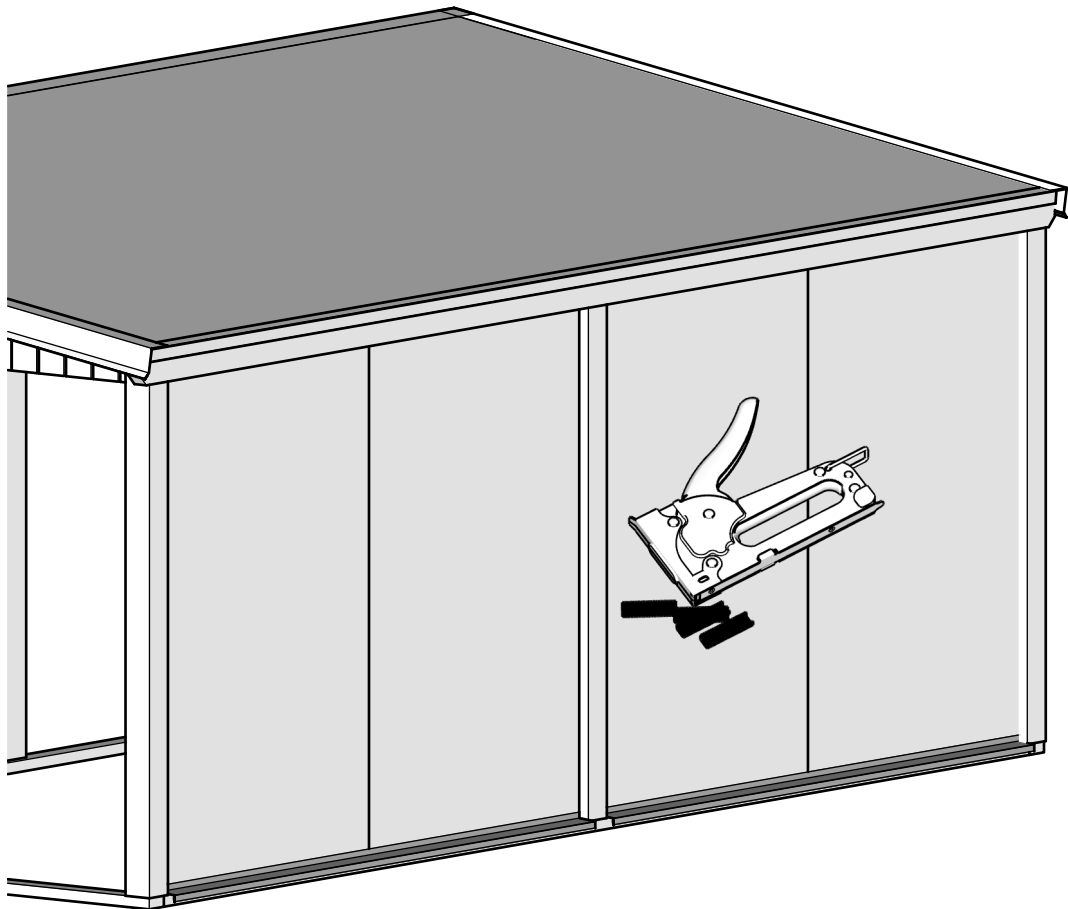
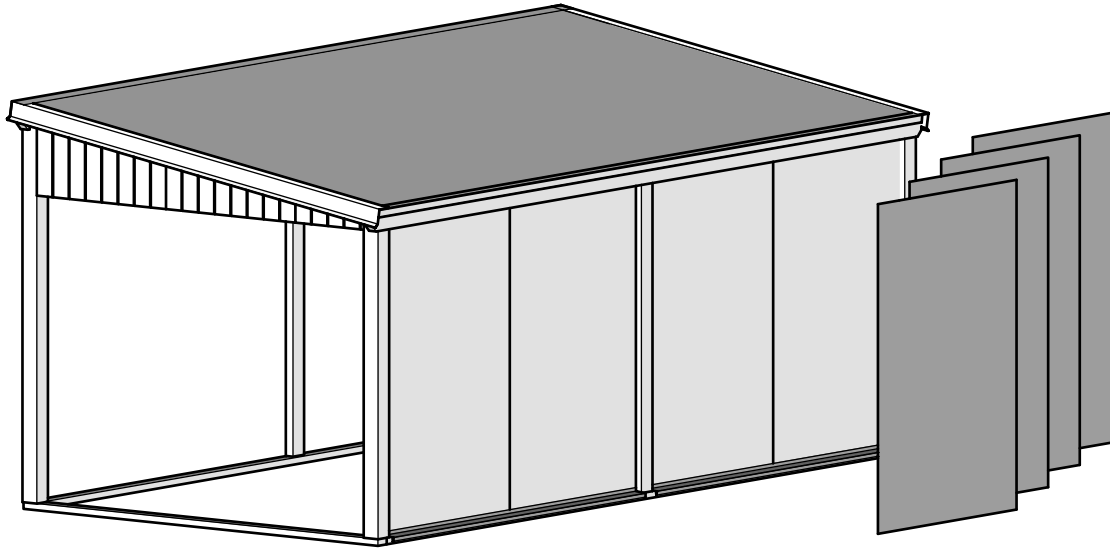
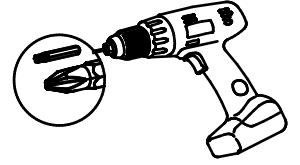
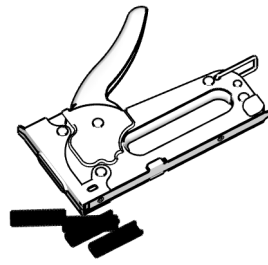
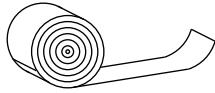

IB1 x12

Ø4,5x60 x96 

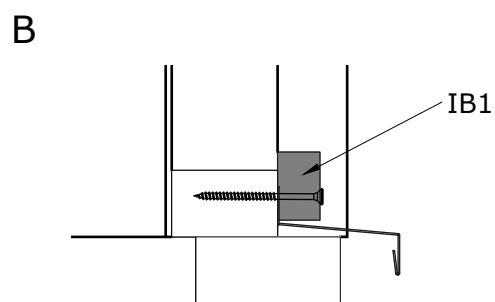
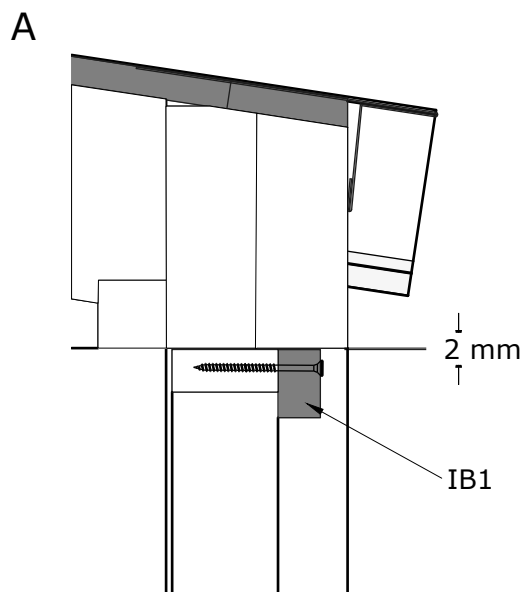
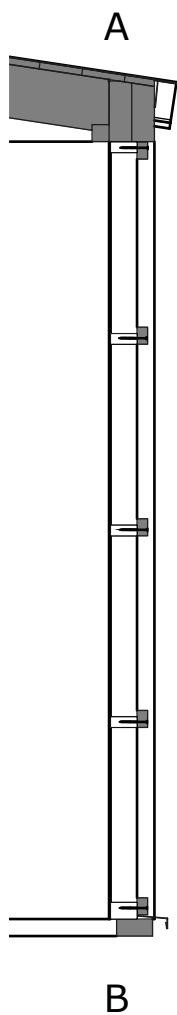
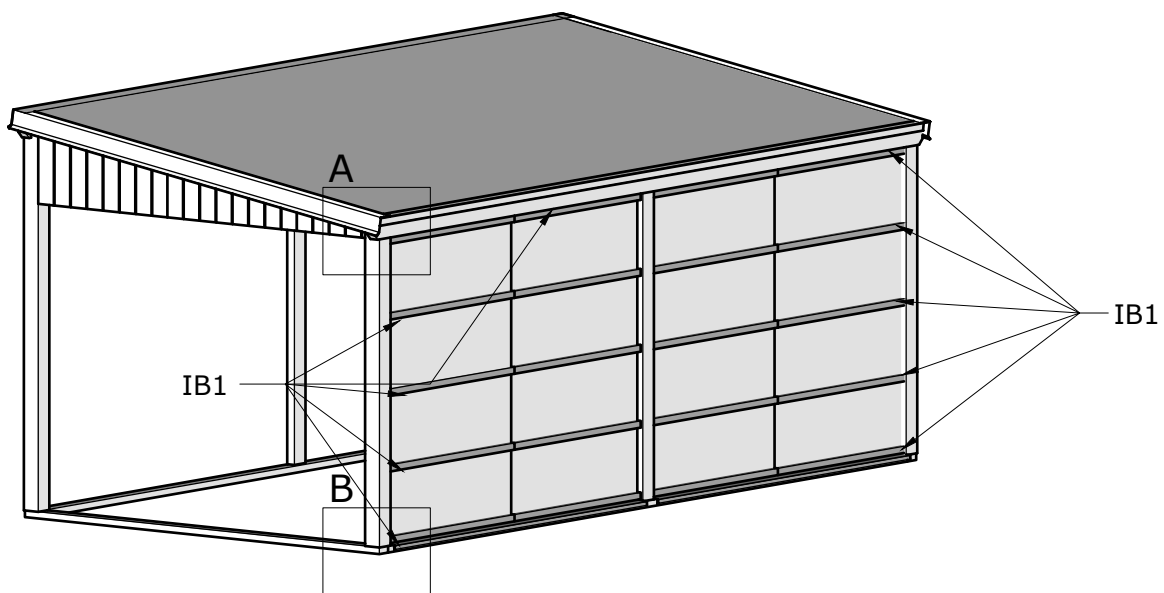
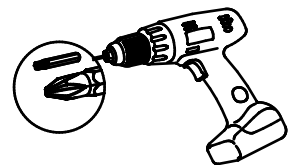

WP5-1 x44



Ø2,5x50 x250

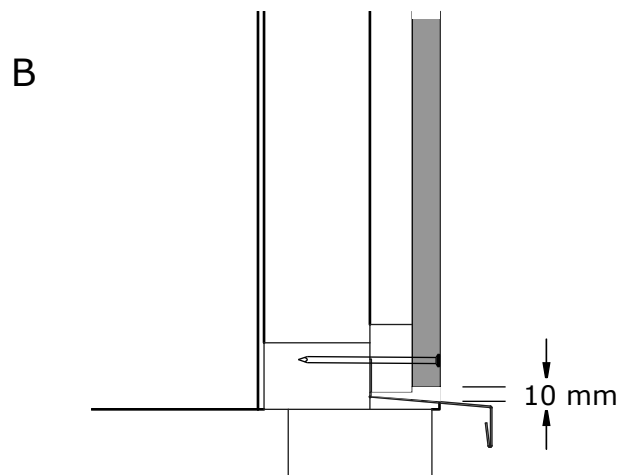
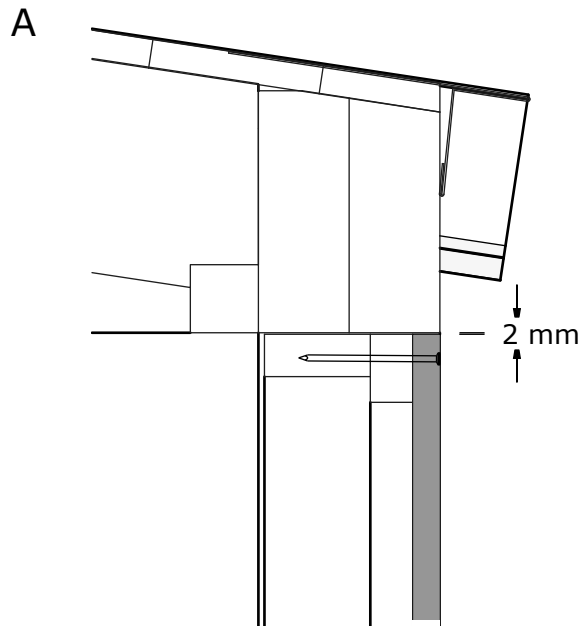
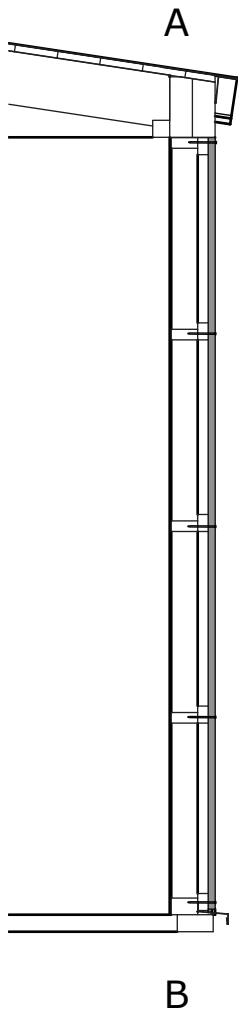
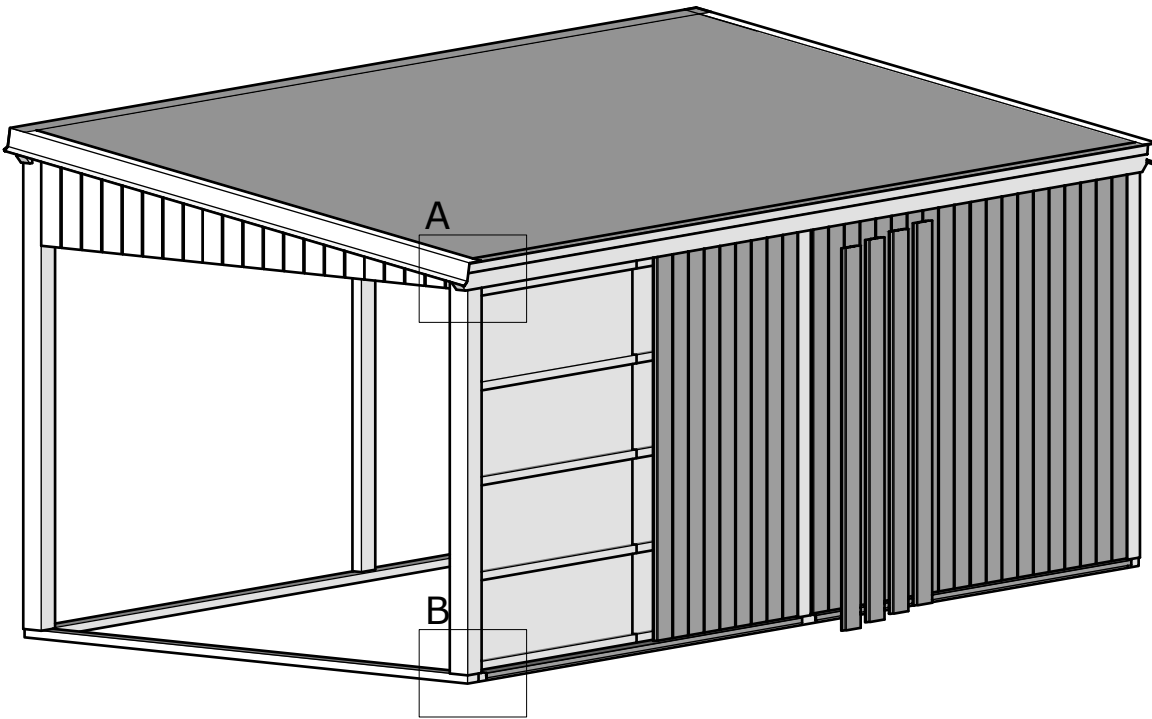
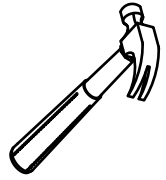
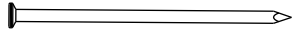

WG8-1 x2

