

AUFBAUANLEITUNG

Gewächshaus „Florentina“

- Ⓜ^{EN} Assembly manual for greenhouse Florentina
- Ⓜ^{FR} Notice de montage du serre Florentina
- Ⓜ^{NL} Opbouwbeschrijving voor tuinkas Florentina
- Ⓜ^{ES} Instrucciones de montaje de invernadero Florentina
- Ⓜ^{IT} Istruzioni di montaggio serra Florentina
- Ⓜ^{DA} Monteringsvejledning for drivhuset Florentina
- Ⓜ^{SV} Monteringsanvisning för växthus Florentina
- Ⓜ^{NO} Monteringsanvisning for drivhus Florentina
- Ⓜ^{PL} Instrukcja montażu szklarnia Florentina
- Ⓜ^{SK} Montážny návod pre skleník Florentina
- Ⓜ^{SL} Priročnik za montažo rastlinjak Florentina
- Ⓜ^{CS} Montážní návod pro skleník Florentina
- Ⓜ^{HU} Felépítési útmutató Florentina üvegház
- Ⓜ^{HR} Priručnik za montažu za staklenik Florentina
- Ⓜ^{RO} Manual asamblare pentru sera Florentina



WICHTIGE PUNKTE FÜR DEN AUFBAU!



**VORLIEGENDE AUFBAUANLEITUNG ZEIGT DEN ZUSAMMENBAU DES
GEWÄCHSHAUSES "FLORENTINA" GRÖSSE „2X1“, SIE GILT SINNGEMÄSS AUCH FÜR ALLE
ANDEREN GRÖSSEN. FÜR EINIGE MONTAGESCHRITTE BENÖTIGEN SIE EINEN HELFER.**

- EN** These assembly instructions show the assembly of a Florentina greenhouse, size „2x1“. They apply accordingly to all other sizes. For some assembly steps you will need a helper.
- FR** Vous trouverez les instructions de montage du serre Florentina pour la taille 2x1. Elles s'appliquent à toutes les autres tailles. Vous aurez besoin d'une deuxième personne pour certaines étapes de montage.
- NL** Deze montagehandleiding toont de montage van een tuinkas Florentina maat „2x1“; zij geldt analoog voor alle andere maten. Voor sommige assemblagestappen zult u een helper nodig hebben.
- ES** Estas instrucciones de montaje muestran cómo montar una invernadero Florentina de tamaño „2x1“. Estas instrucciones se aplican análogamente a todos los demás tamaños. Para algunos pasos de montaje necesitará un ayudante.
- IT** Queste istruzioni di montaggio mostrano come assemblare un serra Florentina „2x1“; si applicano analogamente a tutte le altre dimensioni. Per alcune fasi del montaggio avrete bisogno di un aiutante.
- DA** Samvejledning til drivhuset Florentina i str. 2x1 meter. Fremgangsmåden er ens for alle øvrige størrelser. Det er en god idé at være 2 personer til samlingen.
- SV** Denna monteringsanvisning visar hur man monterar en växthus Florentina i storlek „2x1“; den gäller på motsvarande sätt för alla andra storlekar. För vissa monteringssteg behöver du en medhjälpare.
- NO** Denne monteringsanvisningen viser hvordan du setter sammen et drivhus Florentina størrelse „2x1“; de gjelder analogt for alle andre størrelser. For noen av monteringsstrinnene trenger du en hjelper.
- PL** Niniejsza instrukcja montażu przedstawia sposób montażu szklarnia Florentina w rozmiarze „2x1“. Obowiązują one odpowiednio do wszystkich innych rozmiarów. Do niektórych etapów montażu będziesz potrzebować pomocnika.
- SK** Tento návod na montáž ukazuje, ako zostaviť skleník Florentina veľkosti „2x1“; platí analogicky pre všetky ostatné veľkosti. Pri niektorých krokoch montáže budete potrebovať pomocníka.
- SL** Ta navodila za montažo prikazujejo montažo za rastlinjak Florentina velikosti „2x1“, se ustrezno uporabljajo za vse druge velikosti. Za nekatere korake montaže boste potrebovali pomočnika.
- CS** Tento montážní návod ukazuje, jak sestavit skleník Florentina velikosti „2x1“ na stranách 8-15 a „Zvýšený truhlík na zeleninu“ velikosti „L“ na stranách 16-23; platí obdobně pro všechny ostatní velikosti. Při některých montážních krocích budete potřebovat pomocníka.
- HU** Ez az összeszerelési útmutató Florentina üvegház oldalon a „2x1“ méretű összeszerelését mutatja be, amely értelemszerűen az összes többi méretre is vonatkozik. Néhány összeszerelési lépésnél segítségé lesz szükségesre.
- HR** Ove upute za sastavljanje prikazuju montažu za staklenik Florentina veličine „2x1“; također se odnose na sve ostale veličine. Prilikom montaže, za neke od dijelova, će vam trebati pomoćnik.
- RO** Detalii importante pentru asamblare! Acest manual de asamblare sera Florentina marime „2x1“; este valabil si pentru toate celelalte dimensiuni. Pentru anumiti pasi de asamblare sunt necesare una sau două persoane in plus pentru ajutor.

VERWENDEN SIE BEI DER MONTAGE ARBEITSHANDSCHUHE! UM KRATZER ZU VERMEIDEN, VERWENDEN SIE BITTE GEEIGNETE UNTERLAGEN!

- GB** Wear working gloves! Please use a suitable underlay to avoid scratches!
- FR** Portez des gants de travail! Pour éviter les rayures, utilisez des supports appropriés !
- NL** Handschoenen gebruiken! Om krassen te voorkomen raden wij u aan er iets onder te leggen!
- ES** Utilice unos guantes de trabajo. Por favor, coloque en el suelo una base protectora adecuada para evitar posibles arañazos.
- IT** Utilizzare guanti da lavoro. Utilizzare una base adatta per evitare graffi!
- DK** Brug arbejdshandsker! Brug et passende underlag for at undgå ridser!
- SE** Använd arbetshandskar under monteringen! Använd lämpliga underlag för att undvika repor!
- NO** Bruk arbeidshansker! Bruk et passende underlag for å unngå riper!
- PL** Podczas montażu proszę używać rękawice ochronne. Chronić powierzchnię lakierowaną przed zarysowaniami.
- SK** Používajte pracovné rukavice! Prosím, použite vhodnú podložku, aby ste zabránili poškrábaniu!
- SI** Uporabite delovne rokavice! Uporabite ustrezno podlago, da se izognete praskam!
- CZ** Při montáži použijte pracovní rukavice! Použijte vhodné podložky, abyste se vyhnuli poškrábání!
- HU** Szerelésnél használjon védőkesztyűt! A karcolások elkerülése érdekében használjon megfelelő alátétet!
- HR** Nosite radne rukavice! Upotrijebite odgovarajuće podlagu, da se izognete praskam!
- RO** Purtati manusile de protectie! Va rog sa folositi o baza potrivita pentru a evita zgarieturile!



GRÖSSENABHÄNGIGER MONTAGESCHRITT

Arbeitsschritte, die rot eingerahmt sind, zeigen den Zusammenbau eines größenabhängigen Montageschrittes.

- EN** Size-Dependent assembly step! Assembly steps that are framed in red show the assembly of a size-dependent assembly step
- FR** L'étape d'assemblage dépend de la taille de l'abri! Les étapes de montage encadrées en rouge sont des étapes de montage qui dépendent de la taille.
- NL** Montageshap afhankelijk van de grootte! In rood omkaderde montageschappen zijn niet voor alle maten van toepassing.
- ES** Paso de montaje dependiente del tamaño de la caseta! Los pasos de trabajo enmarcados en rojo muestran el montaje de un paso de montaje dependiente del tamaño.
- IT** Misura-dipendente fase di montaggio! Le fasi di lavoro incorniciate in rosso mostrano l'assemblaggio di una fase di assemblaggio dipendente dalle dimensioni.
- DA** Størrelses-afhængig montage skridt! Monteringsstrin, der er indrammet i rødt, viser samlingen af et størrelsesafhængigt samlingstrin
- SV** Storleksberoende monteringssteg! Monteringssteg som är inramade i rött visar monteringen av ett storleksberoende monteringssteg
- NO** Størrelsesavhengig monteringsstrinn! Monteringsstrinn som er innrammet i rødt viser monteringen av et størrelsesavhengig monteringsstrinn
- PL** Sposób montażu zależny od wielkości. Wskazówki, które są obramowane na czerwono, pokazują kroki montażowe w zależności od rozmiaru
- SK** Montážny krok závislý od veľkosti! Pracovný postup orámovaný červenou farbou znázorňuje montáž montážneho kroku závislého od veľkosti.
- SL** Korak montaže odvisen od velikosti! Koraki montaže, ki so uokvirjeni z rdečo barvo, prikazujejo sestavo koraka montaže, ki je odvisen od velikosti
- CS** Montážní krok závislý na velikosti! Červené orámování znázorňuje sestavení montážního postupu v závislosti na velikosti.
- HU** Mérettől függő összerakási lépés! A piros kerettel ellátott munkalépések egy mérettől függő munkalépés elvégzését jelölik.
- HR** Korak sklopa ovisno o veličini! Koraci montaže koji su uokvirjeni crvenom bojom, prikazuju sastavljanje koraka montaže koji ovisi o veličini
- RO** Pas de asamblare în funcție de mărimea produsului! Pașii de asamblare marcați cu roșu indică asamblarea anumitor componente în funcție de mărimea produsului.



MASSTABSGETREUE ABBILDUNGEN DER ZU VERWENDENDEN SCHRAUBEN (M 1:1)

- EN** Scale drawing 1:1 of the screws in use
- FR** Reproduction selon l'échelle 1:1.
- NL** Afbeelding : schaal 1:1 (ware grootte)
- ES** Reproducción a escala 1:1 de los tornillos que se utilizan para el montaje.
- IT** Immagine in scala delle viti da utilizzare!
- DA** Skala tegning af skruer er 1:1
- SV** Skalenliga ritningar av skruvarna som ska användas:
- NO** Måltegning 1: 1 av skruene som er i bruk
- PL** Skalowane ilustracje używanych śrub:
- SK** Mierka výkresu 1: 1 použitých skrutiek
- SL** Risba v merilu 1: 1 uporabljenih vijakov
- CS** Měřitko výkresu 1: 1 použitých šroubů
- HU** A felhasználandó csavarok méretarányos ábrái:
- HR** Crtež veličine 1: 1 vijaka koji se koriste
- RO** Scala desenului pentru suruburi este 1:1

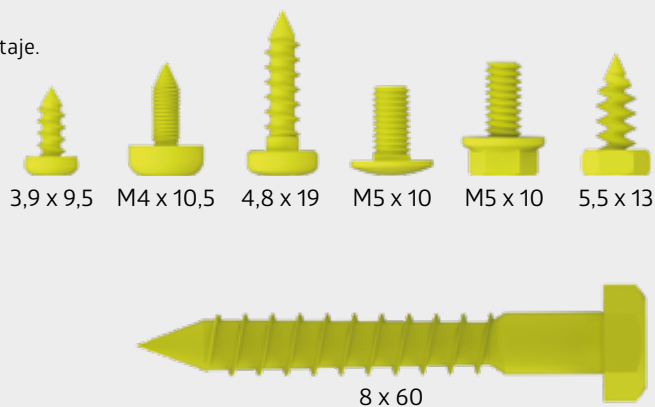

BENÖTIGTE HILFSMITTEL

- EN** Tools required
- FR** Outils requis
- NL** Benodigd gereedschap
- ES** Herramientas necesarias
- IT** Strumenti necessari
- DA** Nødvendigt værktøj
- SV** Verktyg som krävs
- NO** Nødvendig verktøy
- PL** Wymagane narzędzia
- SK** Potrebne nástroje
- SL** Potrebno orodje
- CS** Požadované nástroje
- HU** Szükséges eszközök
- HR** Potrebni alati
- RO** Instrumente necesare





TEILEÜBERSICHT

Parts list · Liste des pièces · Stuklijst · Lista de piezas · Lista de parti · Deloversigt · Delöversikt · Del liste · Przegląd elementów · Zoznam dielov · Seznam delov · Seznam dílů · Tételtekintése · Popis dijelova · Lista pieselor



PROFILPAKET

Profile package · Carton de profils · Profielpakket · Kit de perfiles · Pacco profili · Profilpakke · Profilpaket · Profilpakke · opakowanie zawierające elementy profilowe · Balenie profilov · Profilni paket · Balení profilů · Profilsomag · Paket profila · Pachet profile

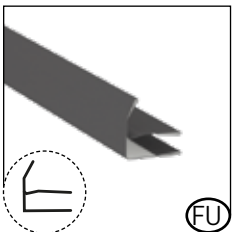
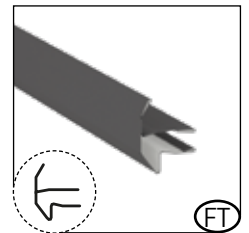
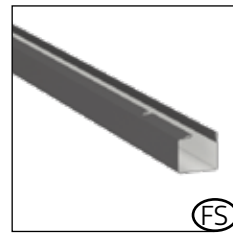
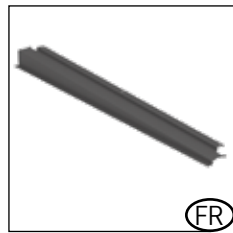
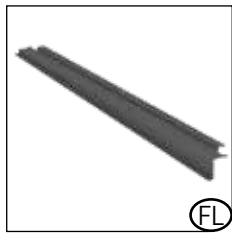
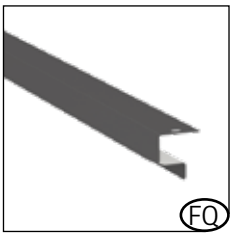
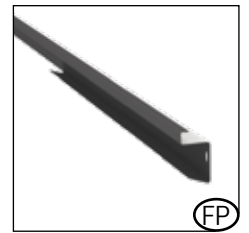
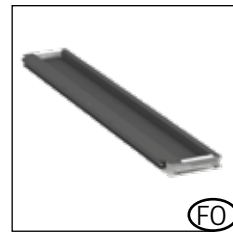
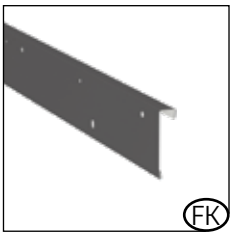
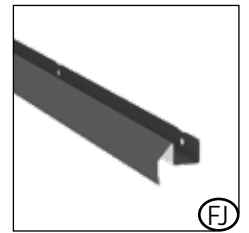
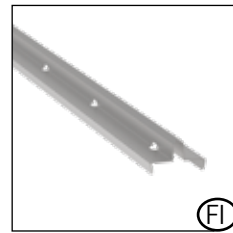
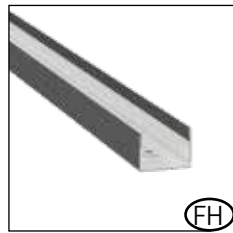
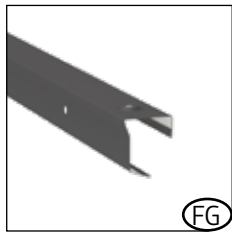
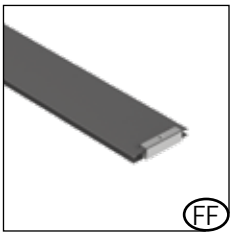
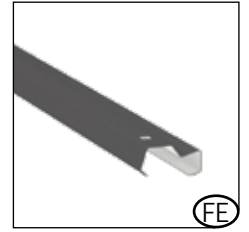
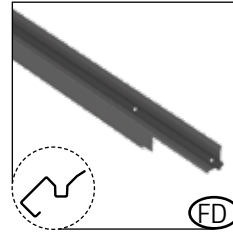
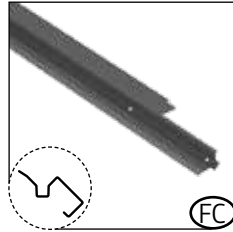
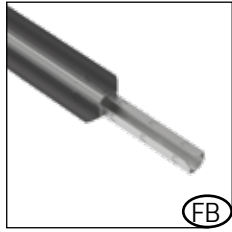
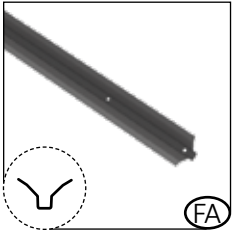

Multi-skin sheet package · paquet de plaques alvéolaires · Pakket met stegplaten · Paquete de placas alveolares · pacchetto lastre alveolari · Pakke med dobbeltvægspalter · paket med multi-skin-ark · Pakke med flere vegger · Pakiet płyt wielokomorowych · Viacvrstvový balík dosiek · Paket večstenskih plošč · Balení vícevrstvých desek · Többrétegű lemezcsomag · Paket višeslojnih ploča · Pachet de foi cu pereți multipli

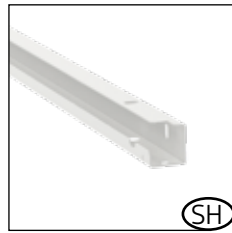
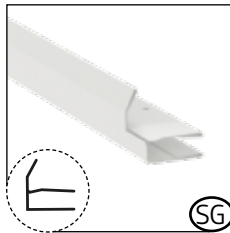
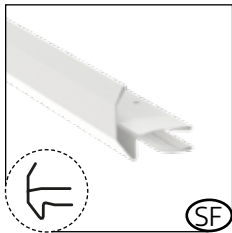
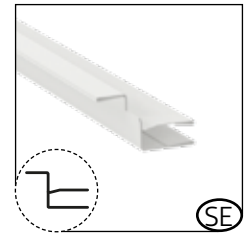
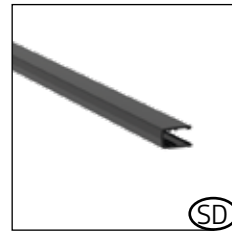
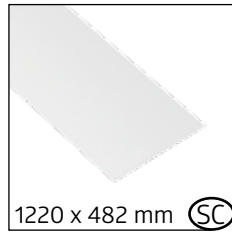
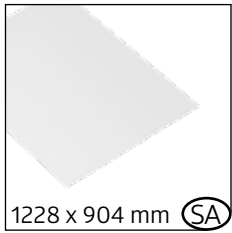

*** NUR FÜR GRÖSSE 2X1M**

(NO) Bare til str 2x1m	(PL) Czynność tylko dla wielkości 2x1m
(GB) Only for size 2x1m	(SK) Len pre veľ. 2x1m
(FR) Uniquement pour taille 2x1m	(SI) Samo za velikosti 2x1m
(NL) Alleen voor maat 2x1m	(CZ) Pouze pro vel. 2x1m
(ES) Sólo para el tamaño 2x1m	(HU) Csak 2x1m-es mérethez
(IT) Solo per misura 2x1m	(HR) Samo za veličine 2x1m
(DK) Kun for størrelse 2x1m	(RO) Doar pentru marime 2x1m
(SE) Endast för storlek 2x1m	

**** NUR FÜR GRÖSSE 2X0,5M**

(NO) Bare til str 2x0.5m	(PL) Czynność tylko dla wielkości 2x0.5m
(GB) Only for size 2x0.5m	(SK) Len pre veľ. 2x0.5m
(FR) Uniquement pour taille 2x0.5m	(SI) Samo za velikosti 2x0.5m
(NL) Alleen voor maat 2x0.5m	(CZ) Pouze pro vel. 2x0.5m
(ES) Sólo para el tamaño 2x0.5m	(HU) Csak 2x0.5m-es mérethez
(IT) Solo per misura 2x0.5m	(HR) Samo za veličine 2x0.5m
(DK) Kun for størrelse 2x0.5m	(RO) Doar pentru marime 2x0.5m
(SE) Endast för storlek 2x0.5m	



TEILEÜBERSICHT

Parts list · Liste des pièces · Stuklijst · Lista de piezas · Lista de parti · Deloversigt · Delöversikt · Del liste · Przegląd elementów · Zoznam dielov · Seznam delov · Seznam dílů · Tétélek áttekintése · Popis dijelova · Lista pieselor



Raised Bed · Potager surélevé · MoestuinBox · huerto urbano elevado · Aiuola Rialzata · Højbed · upphöjd grönsaksbädd · Høybed · Grządka Podwyższona · Vysoký záhon · Visoke grede · Zvýšený truhlík na zeleninu · Magaságyás · Visoka gredica · Jardiniera

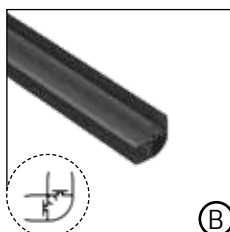
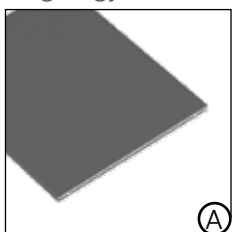

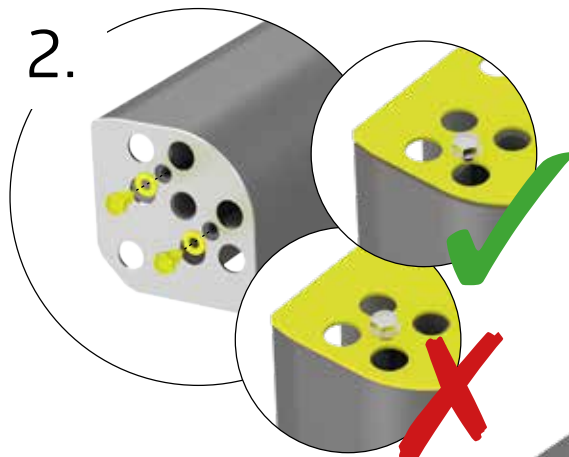
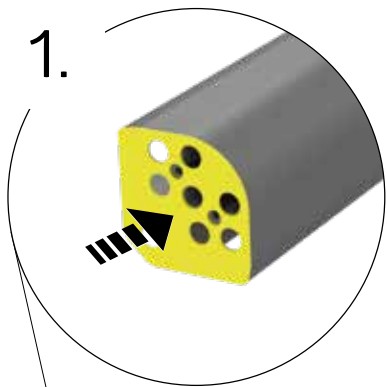
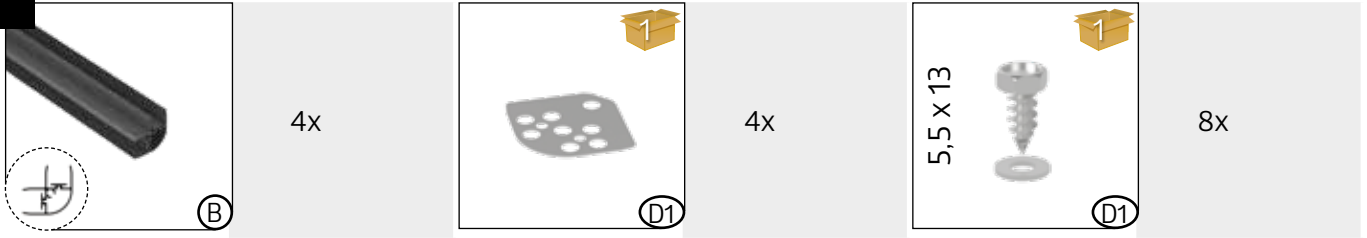

1.



4x

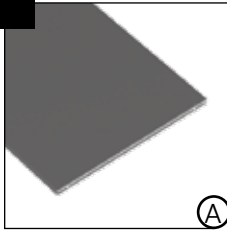

2.

 <p>A</p>	<p>2x0,5: 2X (1928 mm) 1X (451 mm) 2x1: 2X (1928 mm) 1X (943 mm)</p>	<p>4,8 x 19</p>  <p>D1</p>	<p>6x</p>	<p>8 x 60</p>  <p>D1</p>	<p>2x</p>
--	--	---	-----------	---	-----------

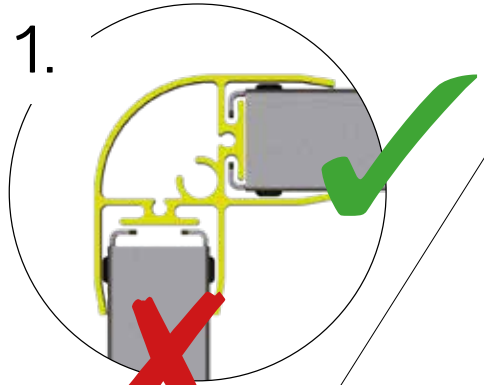
1. 

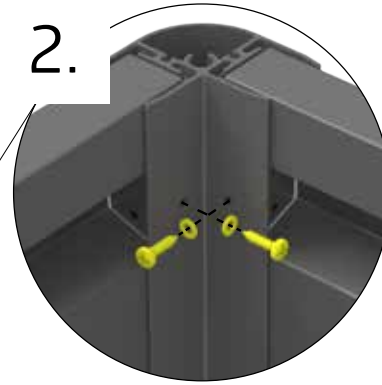
2. 

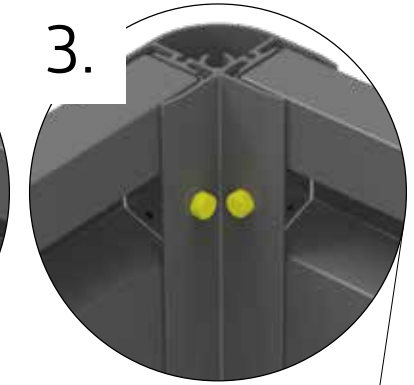
3. 

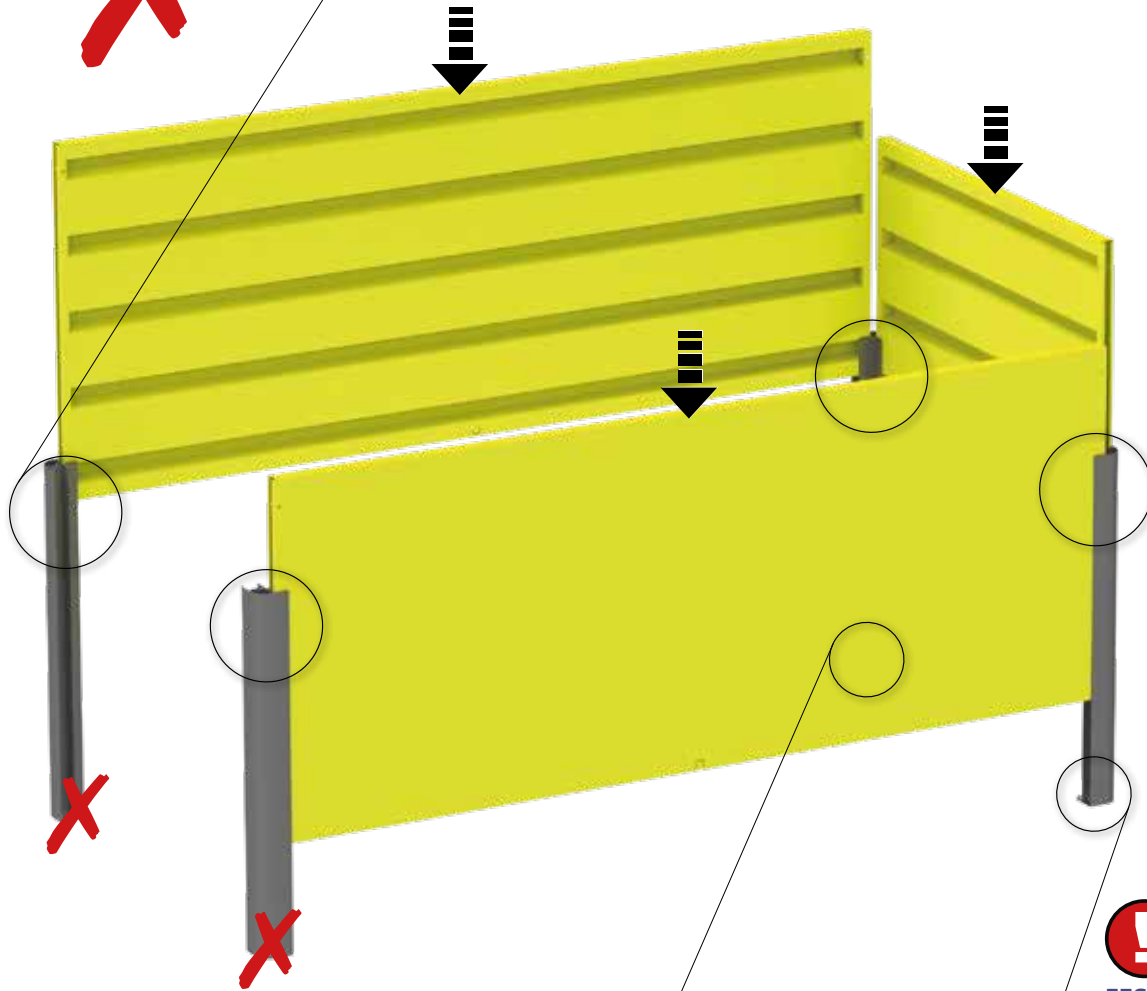

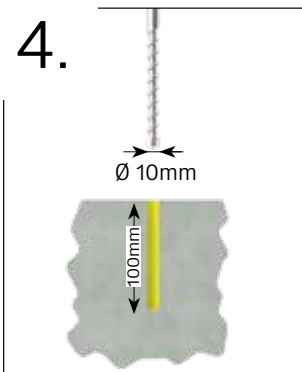

FESTZIEHEN

- ⒺN tighten
- ⒻR serrez fort
- ⒼL vastdraaien
- ⒺS apriete
- ⒾT serrare a fondo
- ⒹA fastspænding
- ⒺV Dra åt
- ⒼO Stramme
- ⒼL Dokręć
- ⒺK Dotiahnuť
- ⒺL Zategnite
- ⒸS Dotáhnout
- ⒼU Erősen meghúzni
- ⒼR Zategnite
- ⒹO Strangeti

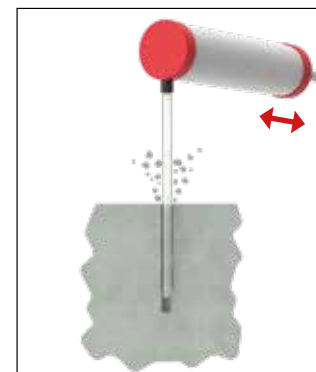
4. 

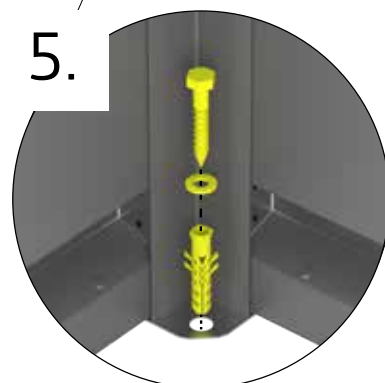
5. 

5. 



AB DIESEM PUNKT DIE ZWISCHENBODEN AUFBAUANLEITUNG VERWENDEN. MUSS NUR AUSGEFÜHRT WERDEN, WENN SIE DAS ZUBEHÖR AUCH BESTELLT HABEN.

(EN) From this point on, please follow the assembly manual for intermediate floor. Only if you have ordered this accessory.

(FR) A partir de cette étape, veuillez utiliser les instructions de montage du sol intermédiaire. A utiliser uniquement si vous avez commandé cet ccessoire.

tillbehör - Tilbehør - akesoría - příslušenstvo - Dodatki - Příslušenství - Tartozék - dodaci - Accesorii

3.

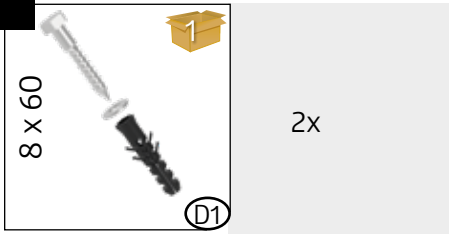

1. RECHTWINKELIG EINRICHTEN

- (EN) Set up at right angles
- (FR) Ajuster en forme rectangulaire
- (NL) Rechthoekig instellen
- (ES) Colóquelo en ángulo recto
- (IT) Installare ad angolo retto
- (DA) Opsættes i rette vinkler
- (SV) Ställ in rät vinkel
- (NO) Settes opp i rett vinkel
- (PL) Ustawić prostopadle
- (SK) Zrovnať do pravého uhla
- (SL) Pripravite in postavite kvadrat
- (CS) Srovnat do pravého úhlu
- (HU) Derékszögbe beállítani
- (HR) Kvadrat osnovice
- (RO) Ajustat rectangular

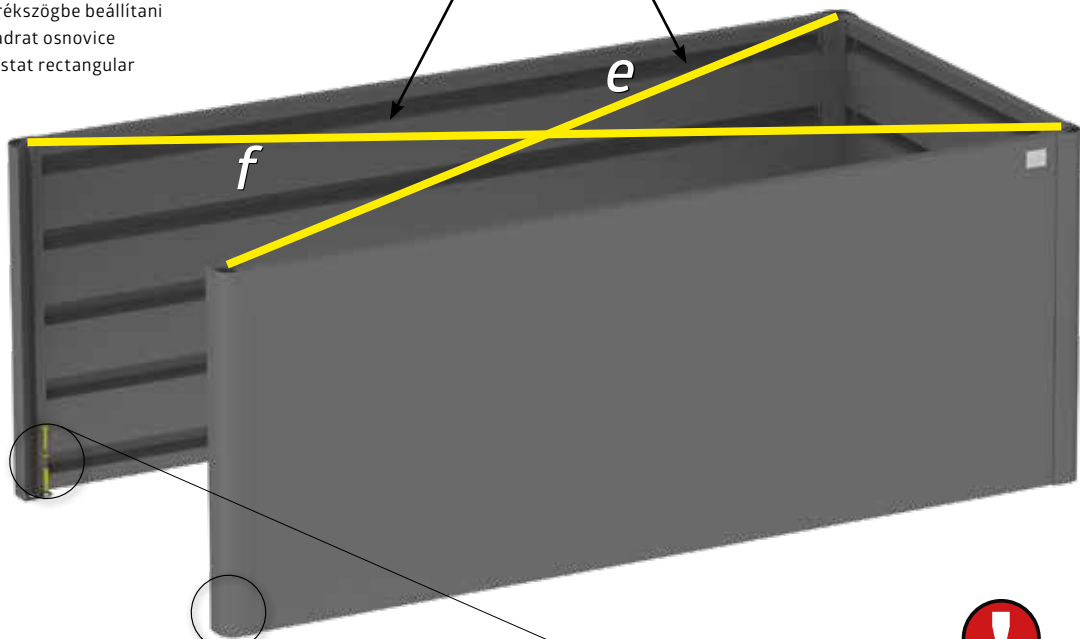

2.

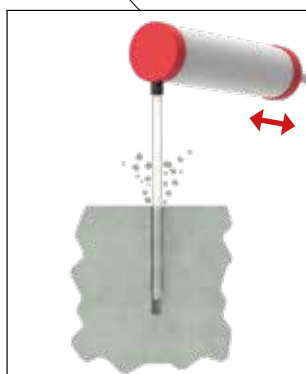
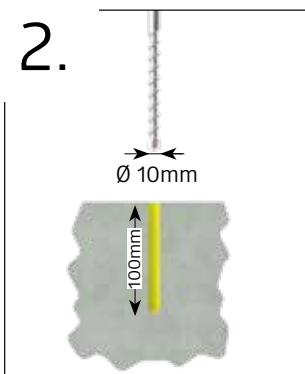

3.

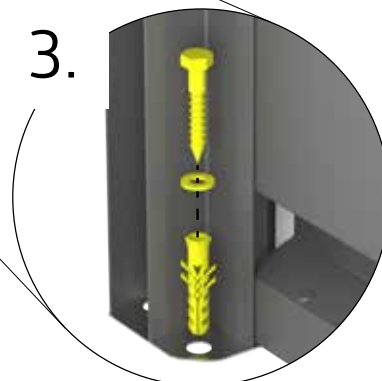

FESTZIEHEN

- (EN) tighten
- (FR) serrez fort
- (NL) vastdraaien
- (ES) apriete
- (IT) serrare a fondo
- (DA) fastspænding
- (SV) Dra åt
- (NO) Stramme
- (PL) Dokręcić
- (SK) Dotiahnuť
- (SL) Zategnite
- (CS) Dotáhnout
- (HU) Erősen meghúzni
- (HR) Zategnite
- (RO) Strangeti

4.

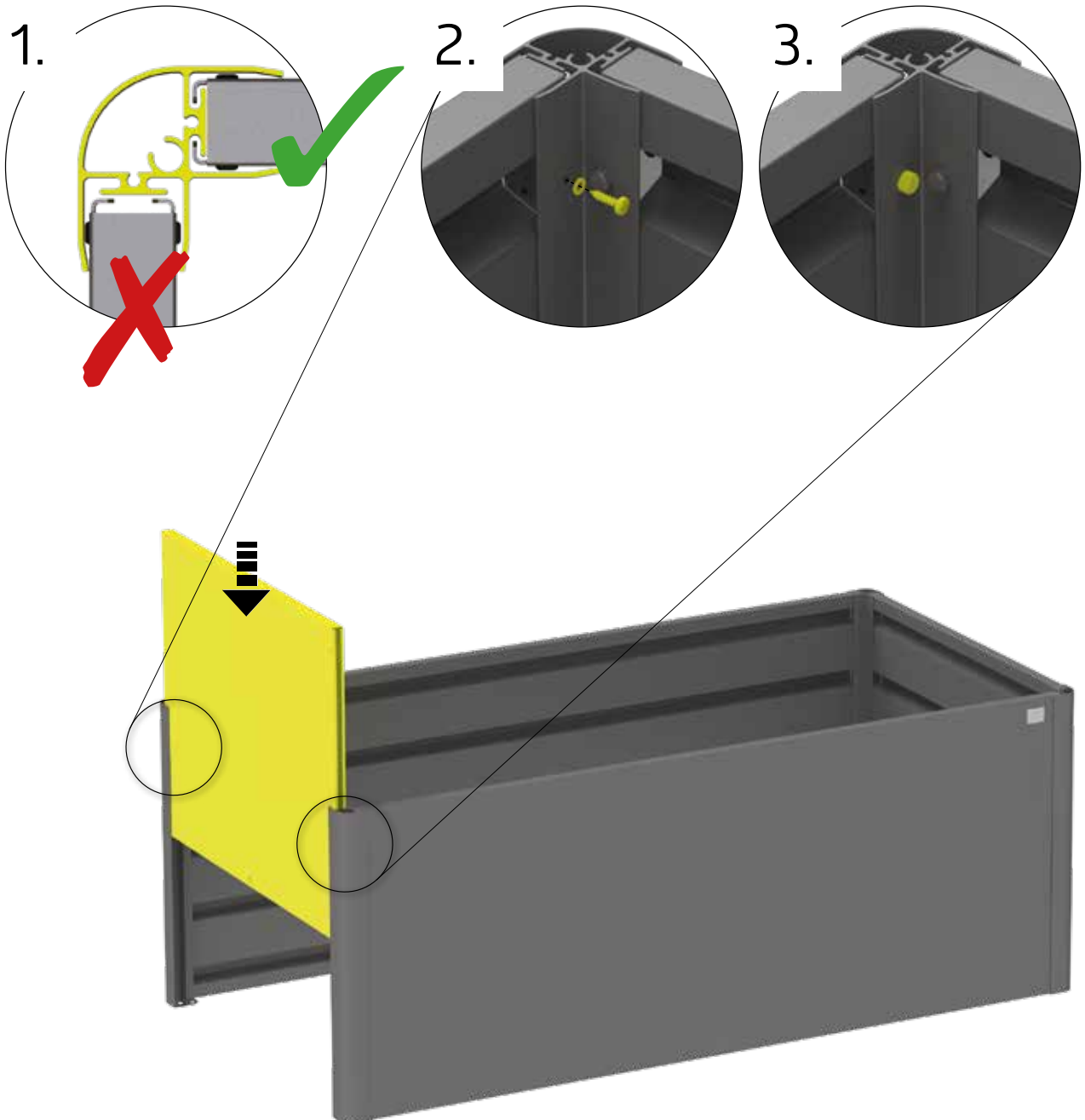
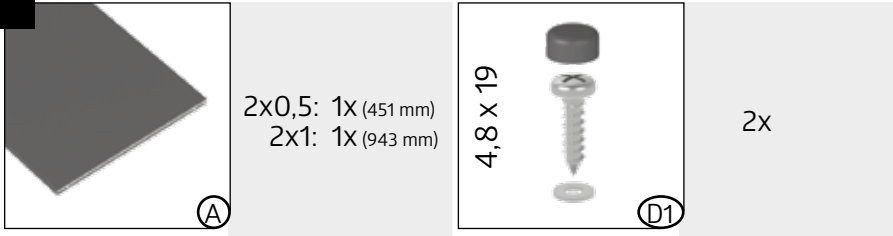

5.

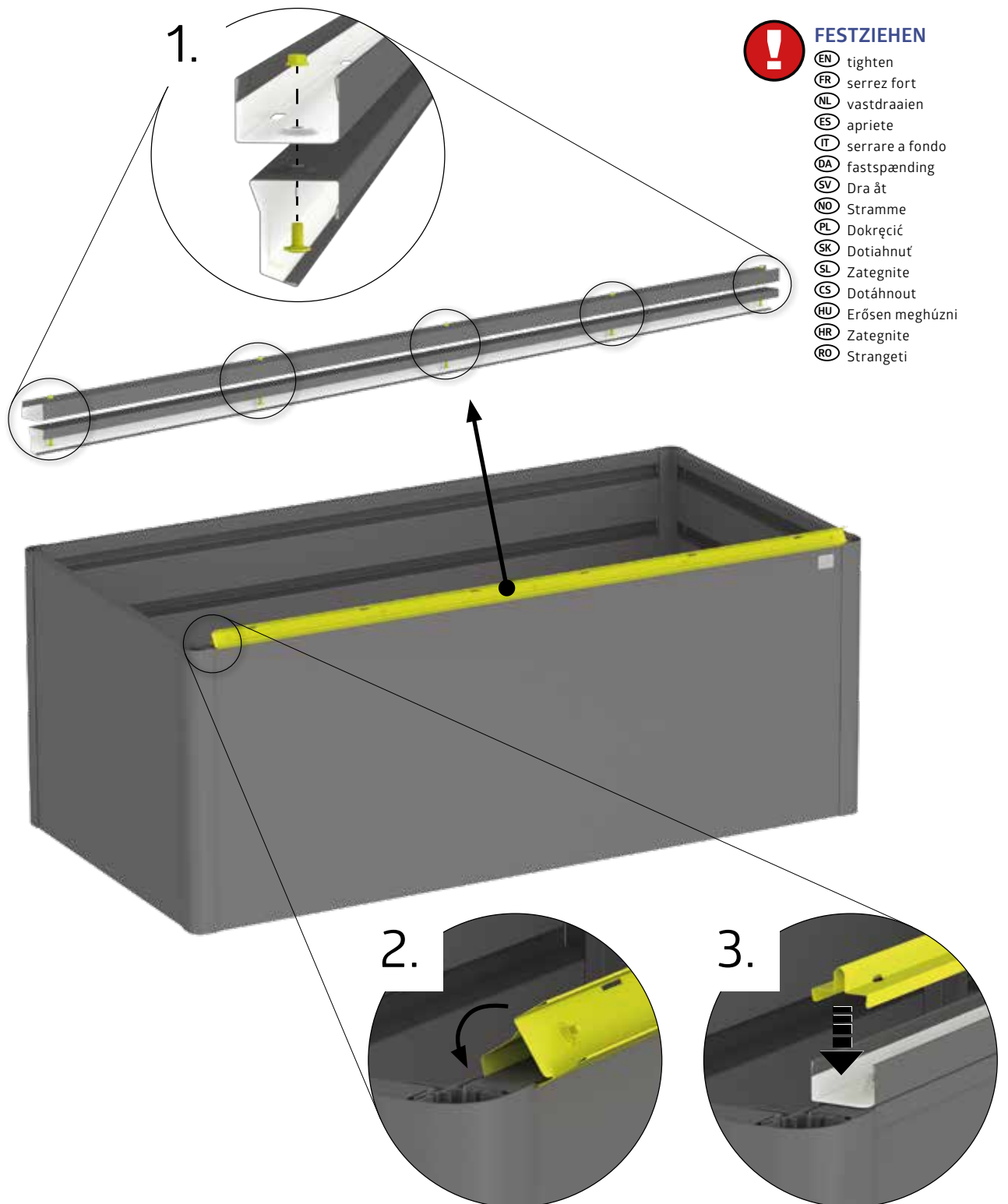
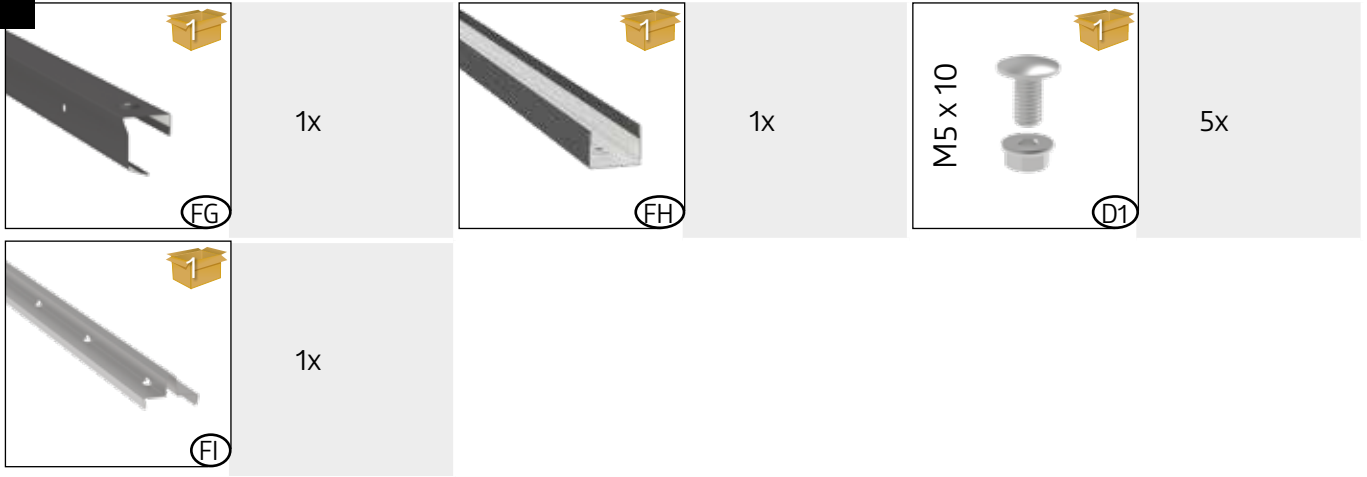

6.

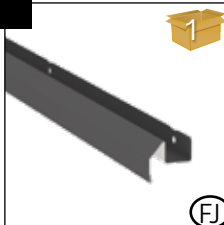
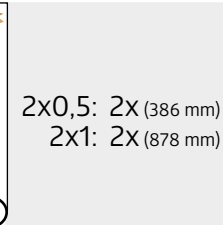
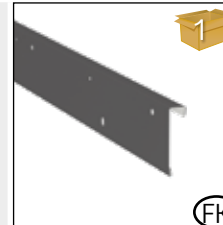
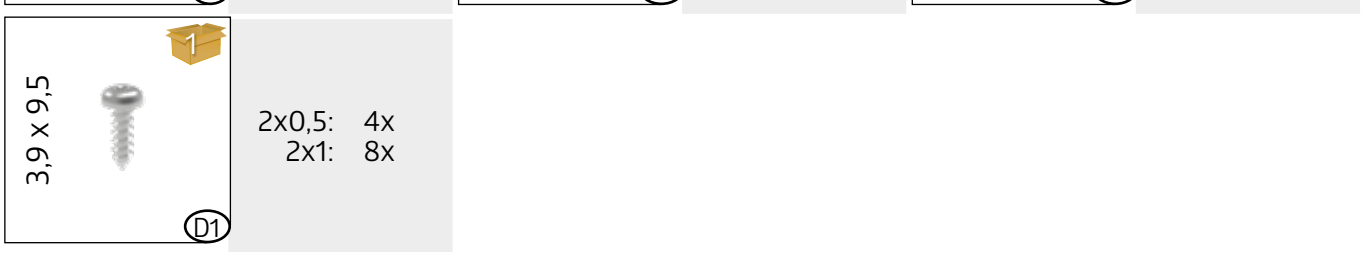
 <p>2x0,5: 2x (386 mm) 2x1: 2x (878 mm)</p> <p>(FJ)</p>	 <p>2x0,5: 2x (386 mm) 2x1: 2x (878 mm)</p> <p>(FK)</p>	 <p>2x0,5: 4x 2x1: 8x</p> <p>(D1)</p>
 <p>3,9 x 9,5</p> <p>2x0,5: 4x 2x1: 8x</p> <p>(D1)</p>		

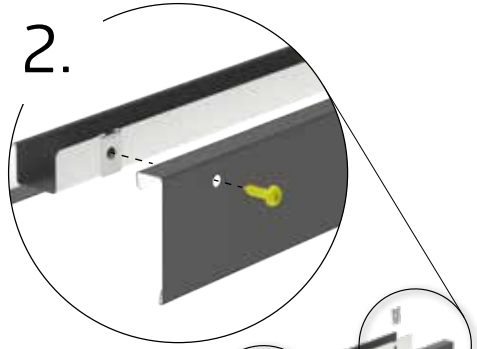
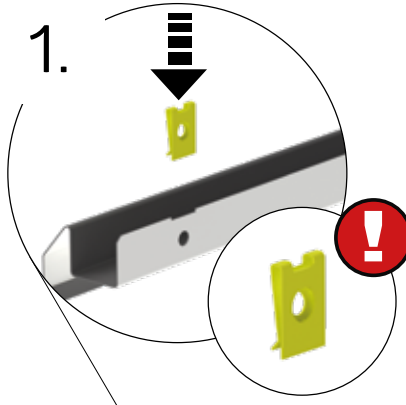

- FESTZIEHEN**
- (EN) tighten
 - (FR) serrez fort
 - (NL) vastdraaien
 - (ES) apriete
 - (IT) serrare a fondo
 - (DA) fastspænding
 - (SV) Dra åt
 - (NO) Stramme
 - (PL) Dokręcić
 - (SK) Dotiahnuť
 - (SL) Zategnite
 - (CS) Dotáhnout
 - (HU) Erősen meghúzni
 - (HR) Zategnite
 - (RO) Strangeti

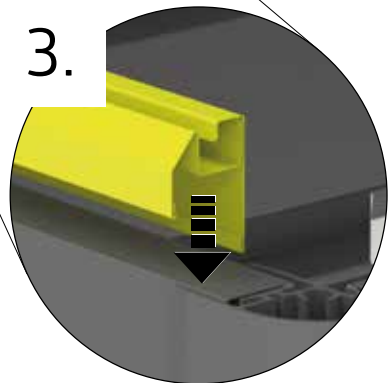
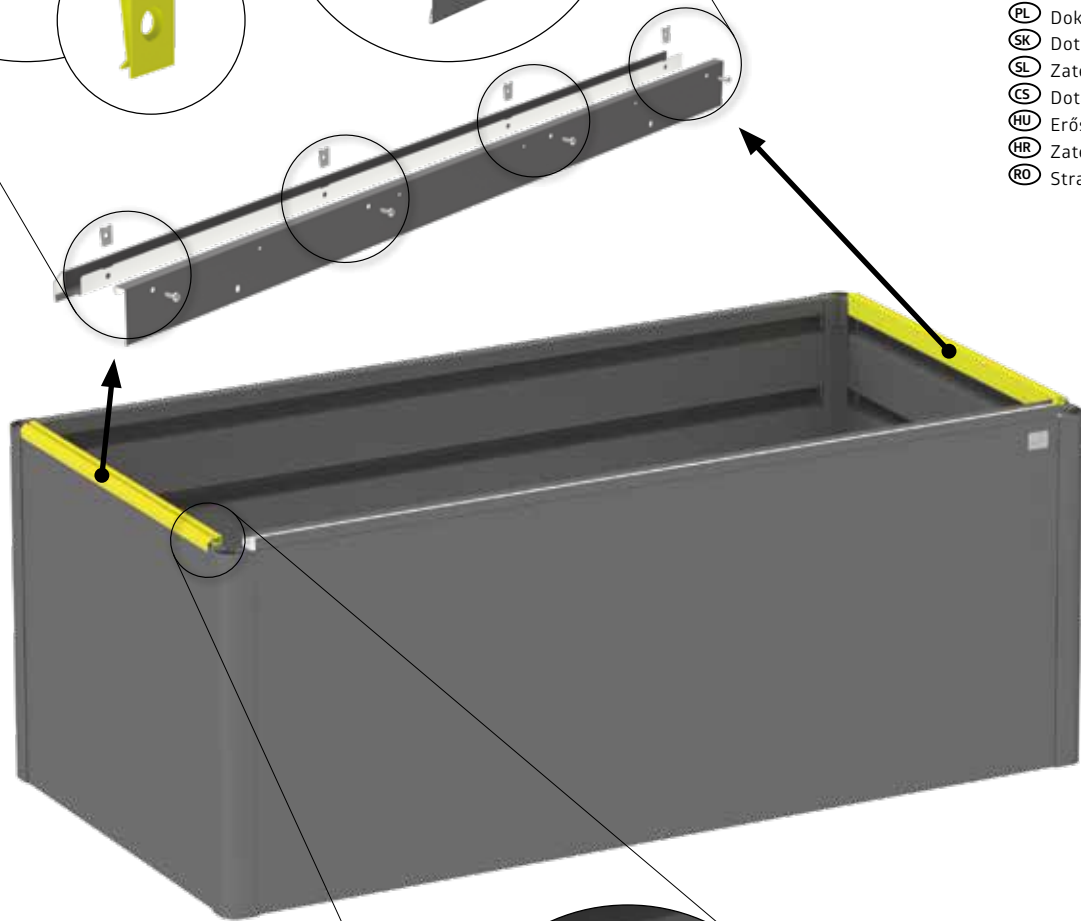

7.

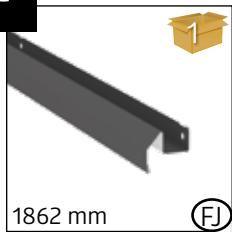

1x

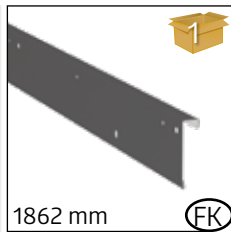

1x

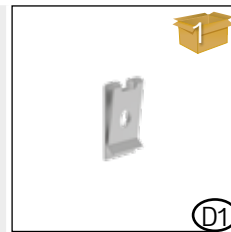

6x

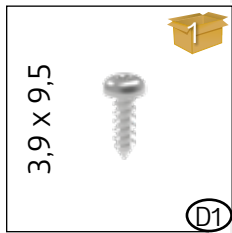

14x



FESTZIEHEN

- (EN) tighten
- (FR) serrez fort
- (NL) vastdraaien
- (ES) apriete
- (IT) serrare a fondo
- (DA) fastspænding
- (SV) Dra åt
- (NO) Stramme
- (PL) Dokręcić
- (SK) Dotiahnuť
- (SL) Zategnite
- (CS) Dotáhnout
- (HU) Erősen meghúzni
- (HR) Zategnite
- (RO) Strangeti

1.

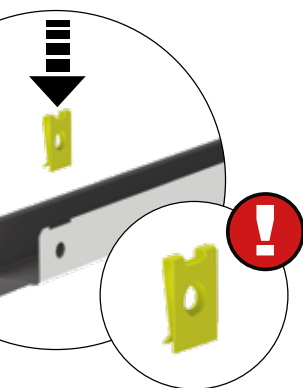

2.

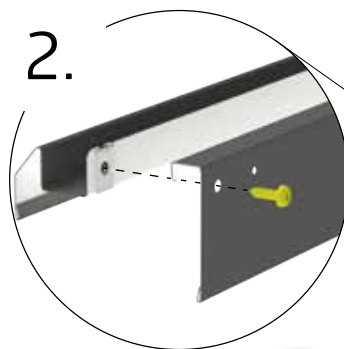

3.

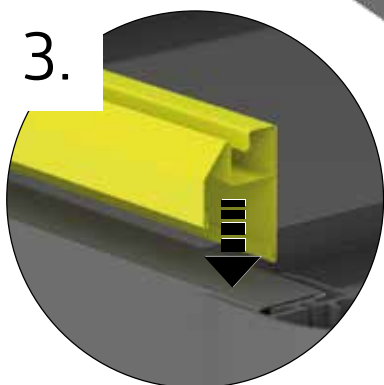

4.

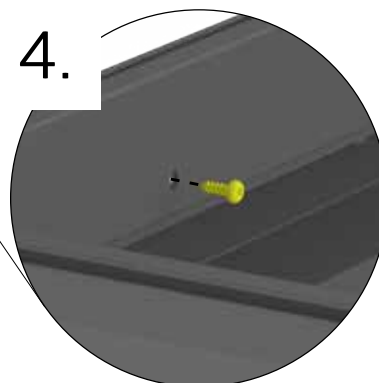

FESTZIEHEN

- (EN) tighten
- (FR) serrez fort
- (NL) vastdraaien
- (ES) apriete
- (IT) serrare a fondo
- (DA) fastspænding
- (SV) Dra åt
- (NO) Stramme
- (PL) Dokręcić
- (SK) Dotiahnuť
- (SL) Zategnite
- (CS) Dotáhnout
- (HU) Erősen meghúzni
- (HR) Zategnite
- (RO) Strangeti

8.

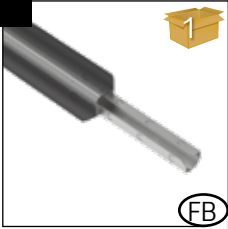
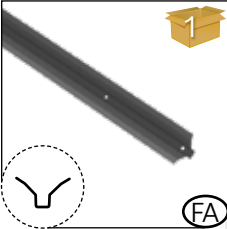
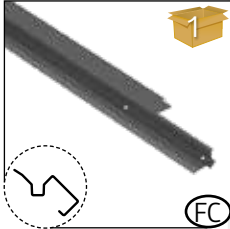
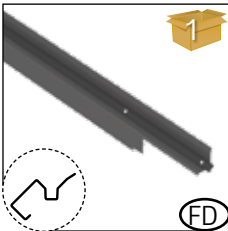
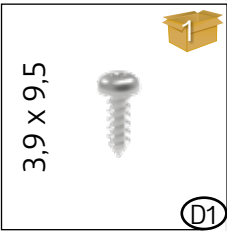
 1 FB	4x	 1 FA	2x	 1 FC	1x
 1 FD	1x	 1 3,9 x 9,5 D1	20x		

2x

1x

1x

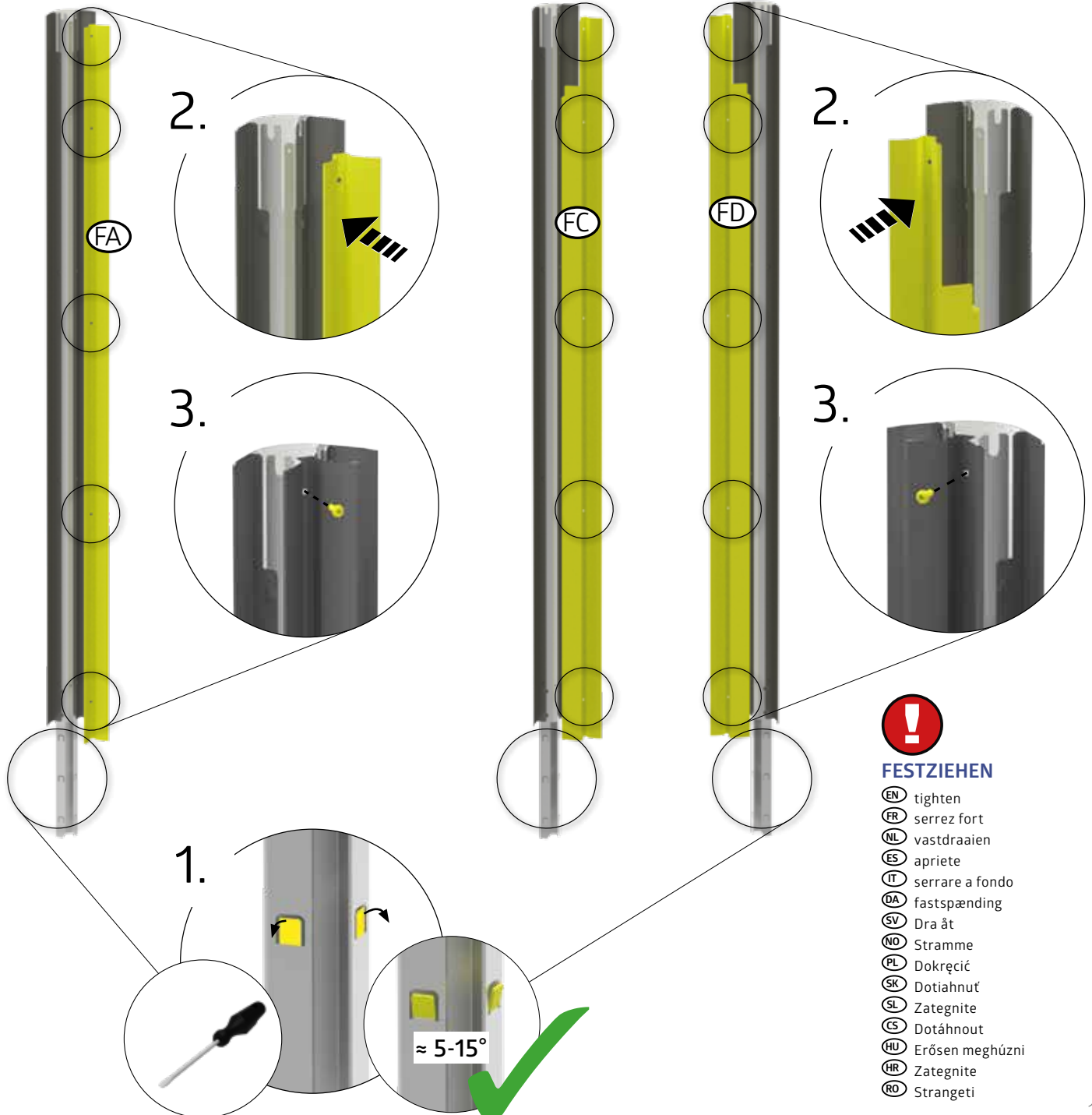

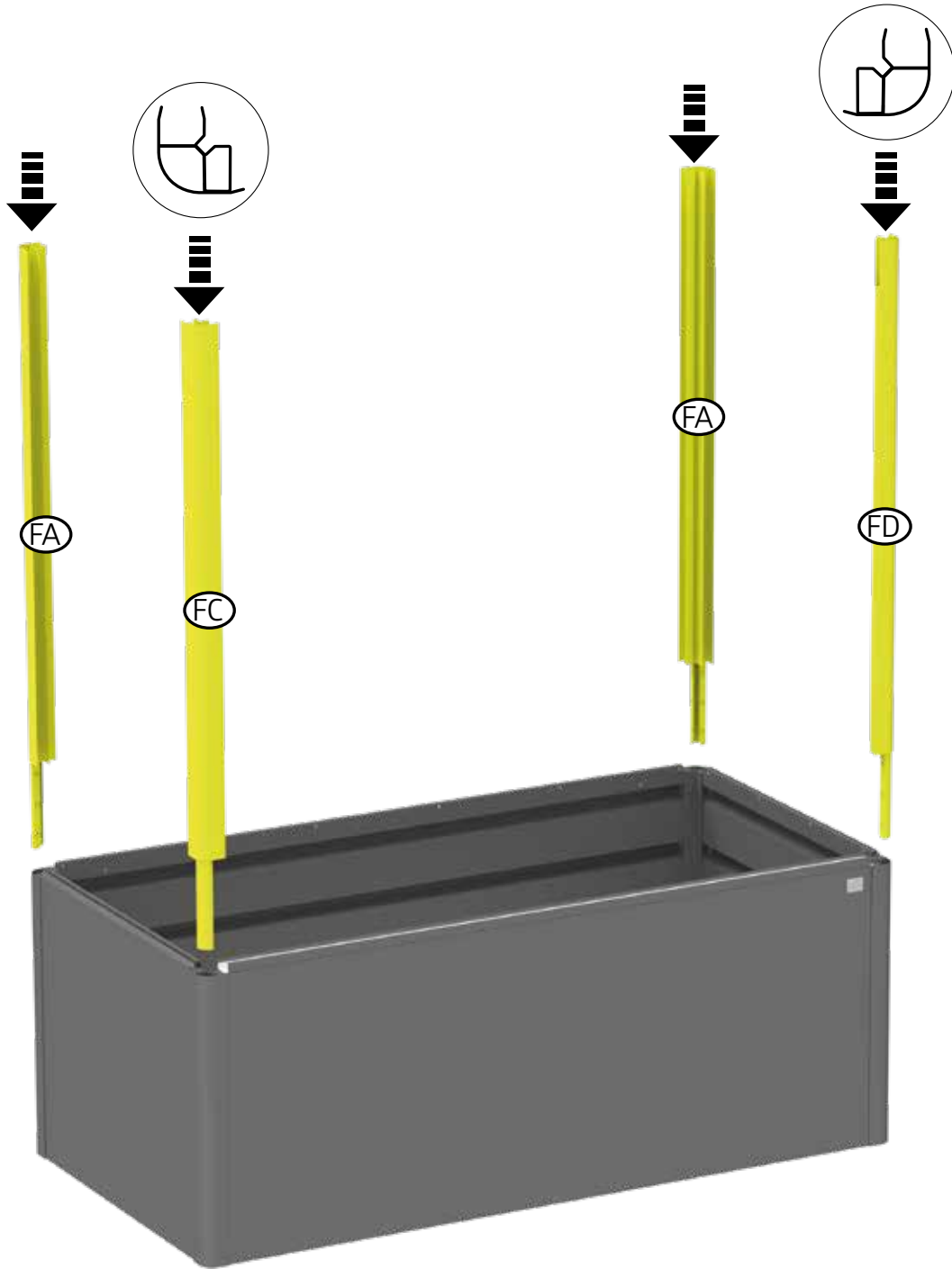



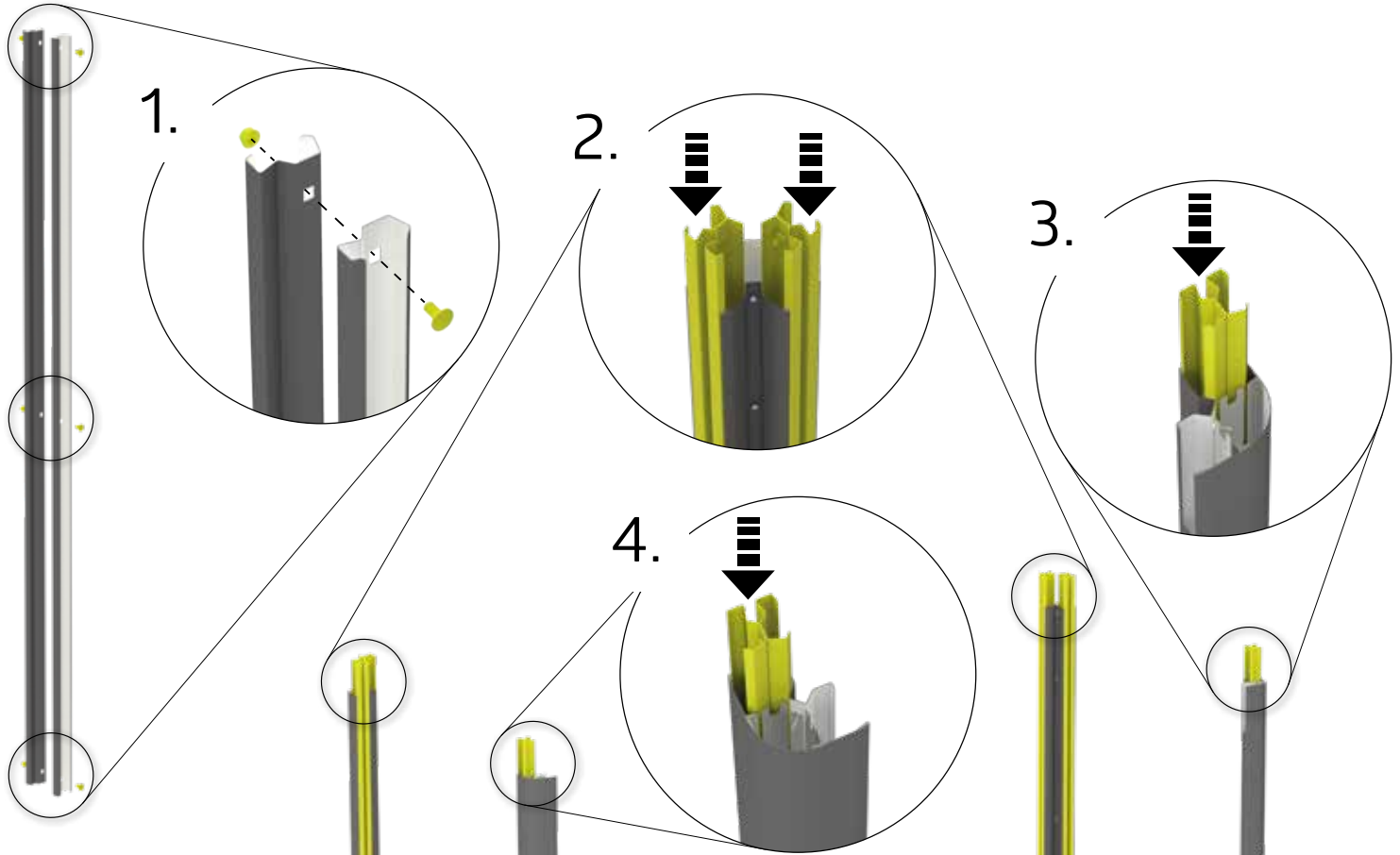
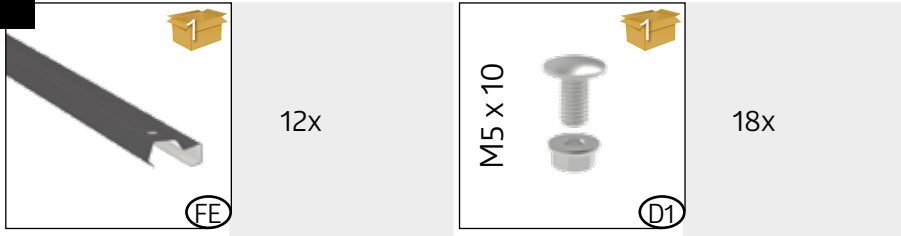



10.

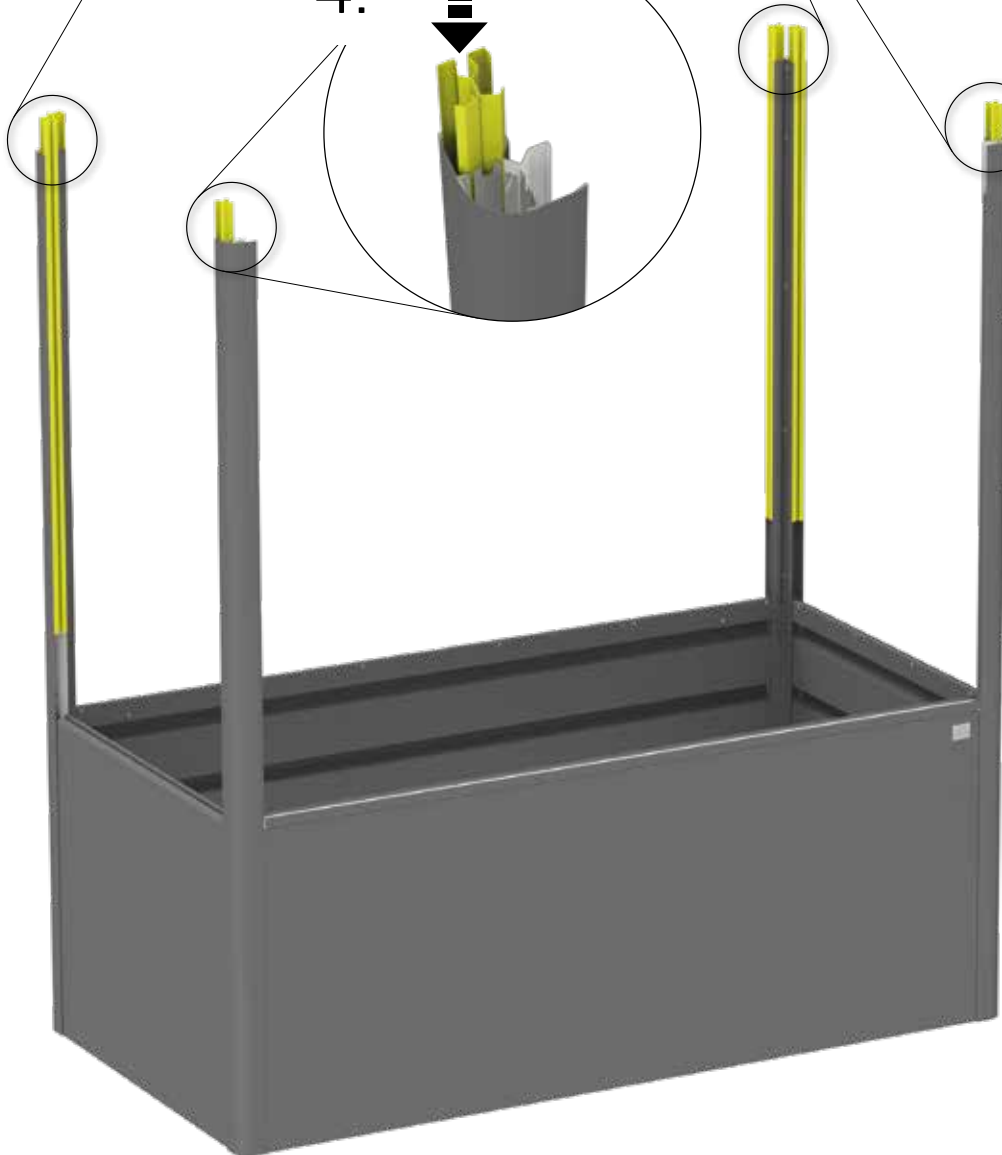

FESTZIEHEN

- (EN) tighten
- (FR) serrez fort
- (NL) vastdraaien
- (ES) apriete
- (IT) serrare a fondo
- (DA) fastspænding
- (SV) Dra åt
- (NO) Stramme
- (PL) Dokręcić
- (SK) Dotiahnuť
- (SL) Zategnite
- (CS) Dotáhnout
- (HU) Erősen meghúzni
- (HR) Zategnite
- (RO) Strangeti



 <p>1228 x 904 mm (SA)</p>	<p>2x0,5: 2x 2x1: 4x</p>	 <p>985 x 630 mm (SB)</p>	<p>2x0,5: 0x 2x1: 3x</p>	 <p>1220 x 482 mm (SC)</p>	<p>4x</p>
 <p>(D1)</p>	<p>1x</p>	 <p>1228 x 412 mm (SA)</p>	<p>2x0,5: 2x 2x1: 0x</p>	 <p>493 x 630 mm (SB)</p>	<p>2x0,5: 3x 2x1: 0x</p>

SCHUTZFOLIE ABZIEHEN!

- (EN) Remove the protective film!
- (FR) Retirez le film protecteur !
- (NL) Verwijder de beschermfolie!
- (ES) ¡Retire la película protectora!
- (IT) Rimuovere la pellicola protettiva!
- (DA) Fjern beskyttelsesfilmen!
- (SV) Ta bort skyddsfilmen!
- (NO) Fjern beskyttelsesfilmen!
- (PL) Zdejmij folię ochronną!
- (SK) Odstráňte ochrannú fóliu!
- (SL) Odstranite zaščitno folijo!
- (CS) Odstraňte ochrannou fólii!
- (HU) Erősen meghúzni
- (HR) Távolítsa el a védőfóliát!
- (RO) Îndepărtați folia de protecție!

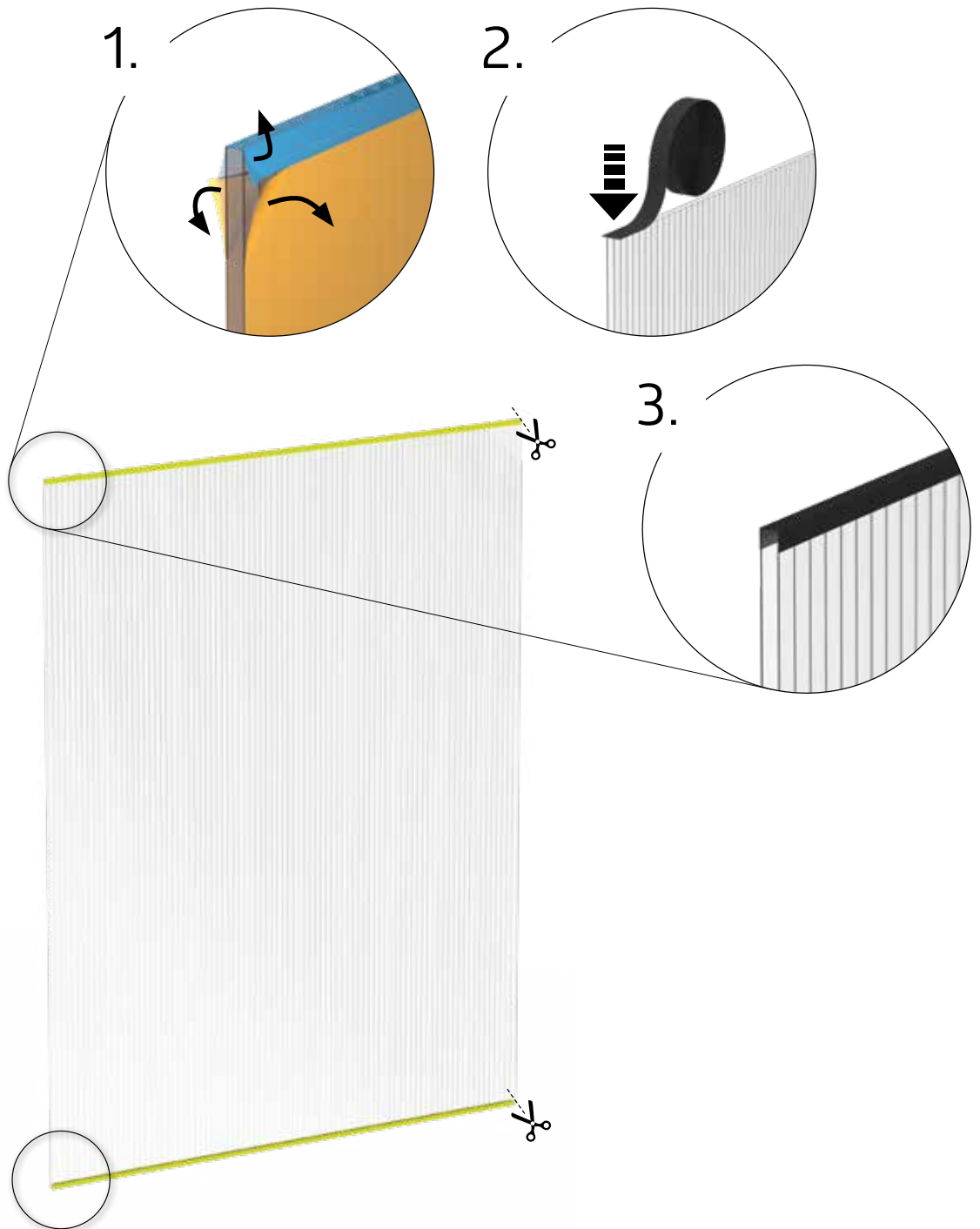

12.

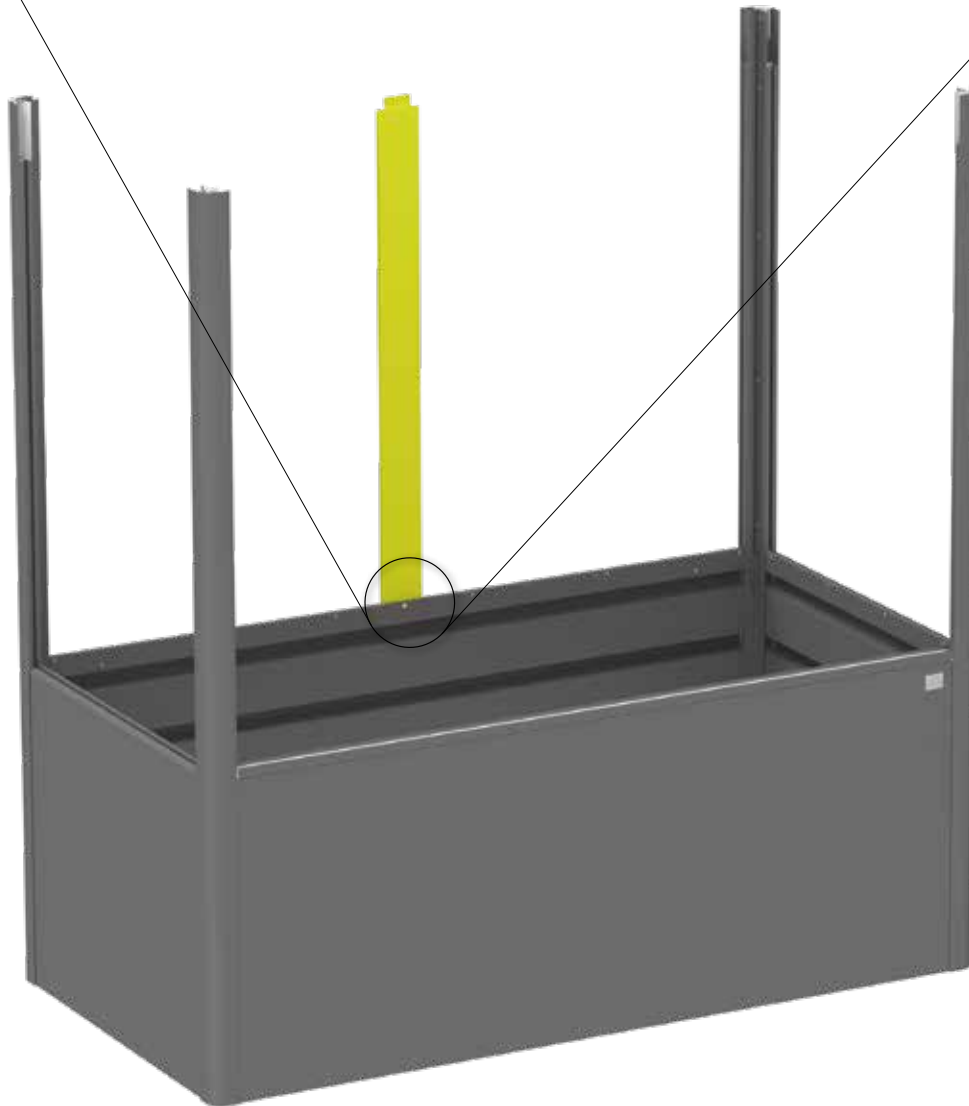
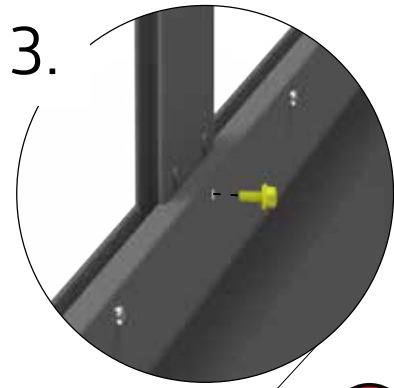
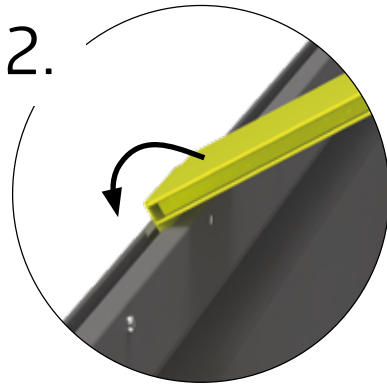
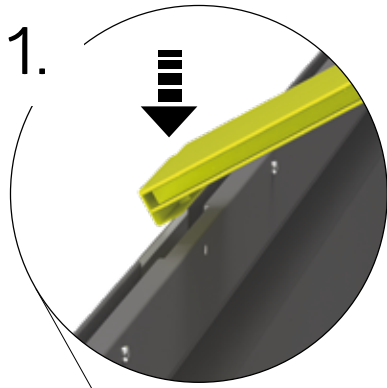
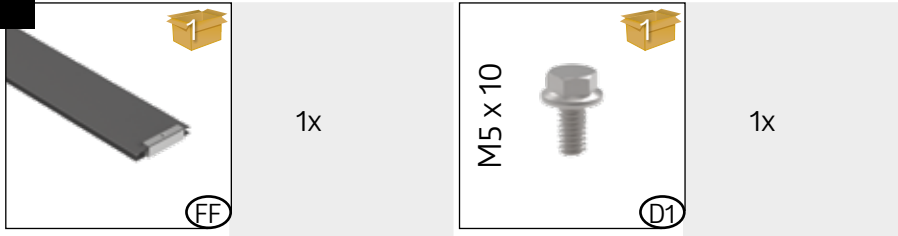

FESTZIEHEN

- (EN) tighten
- (FR) serrez fort
- (NL) vastdraaien
- (ES) apriete
- (IT) serrare a fondo
- (DA) fastspænding
- (SV) Dra åt
- (NO) Stramme
- (PL) Dokręcić
- (SK) Dotiahnuť
- (SL) Zategnite
- (CS) Dotáhnout
- (HU) Erősen meghúzni
- (HR) Zategnite
- (RO) Strangeti

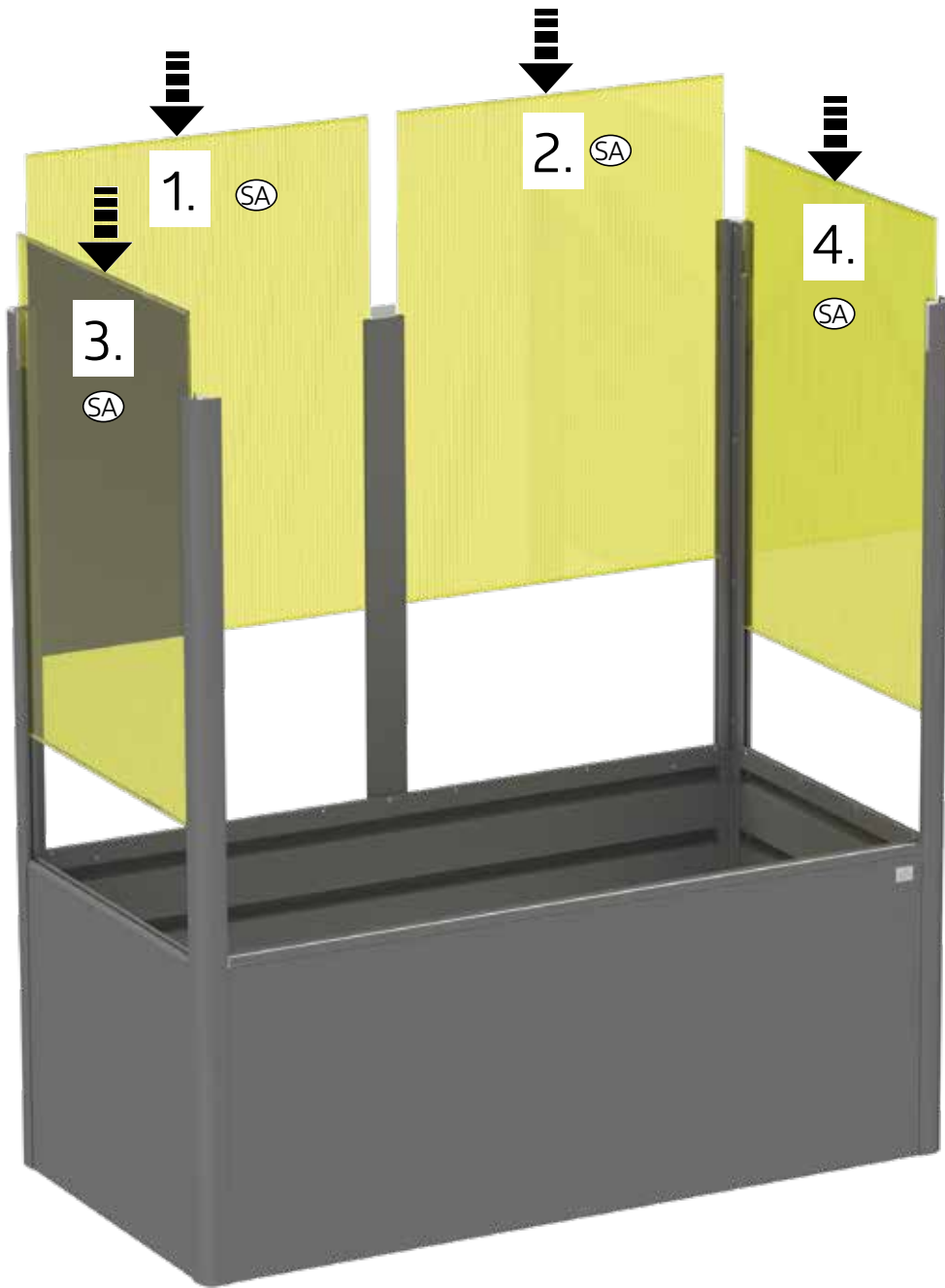

14.

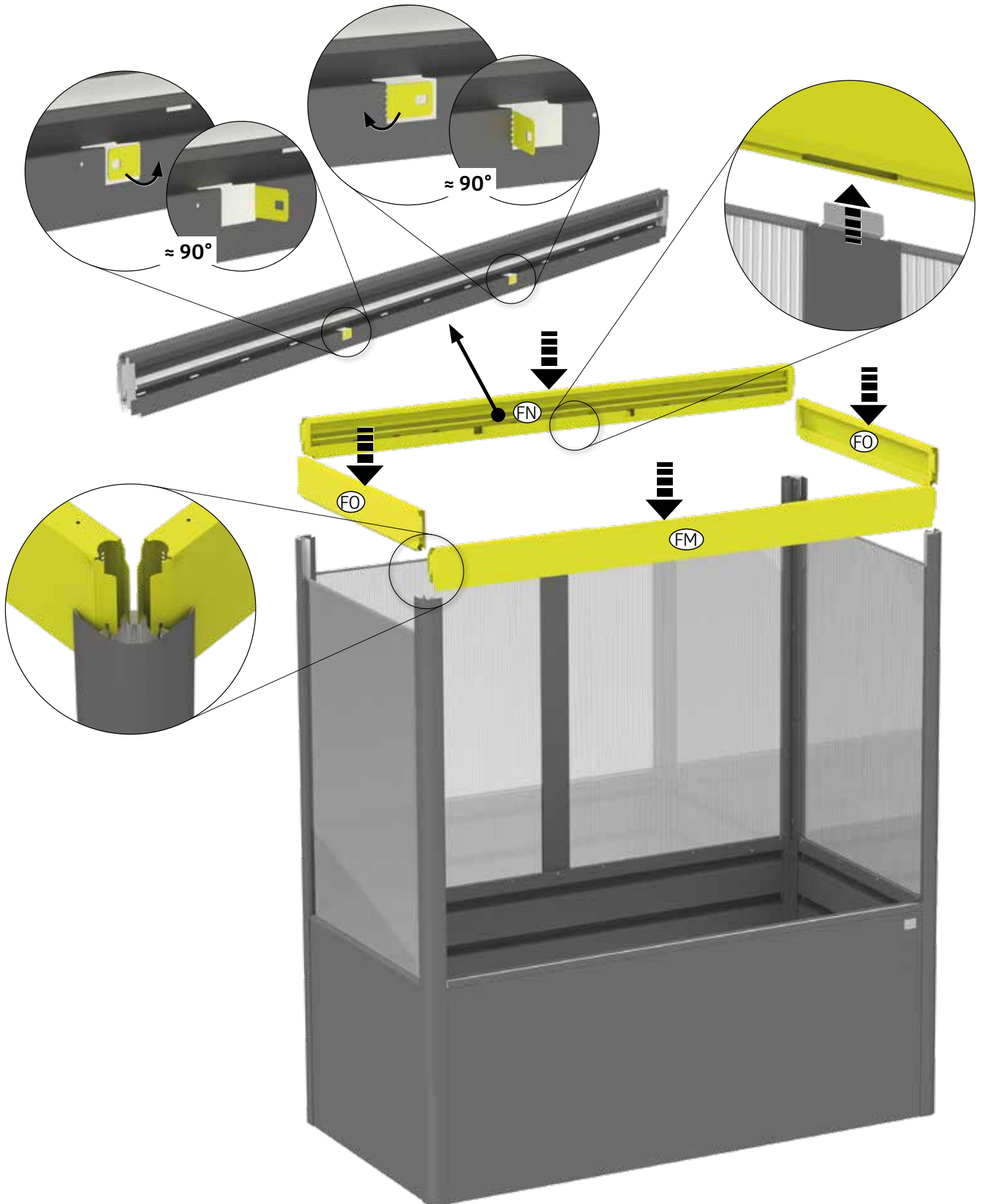
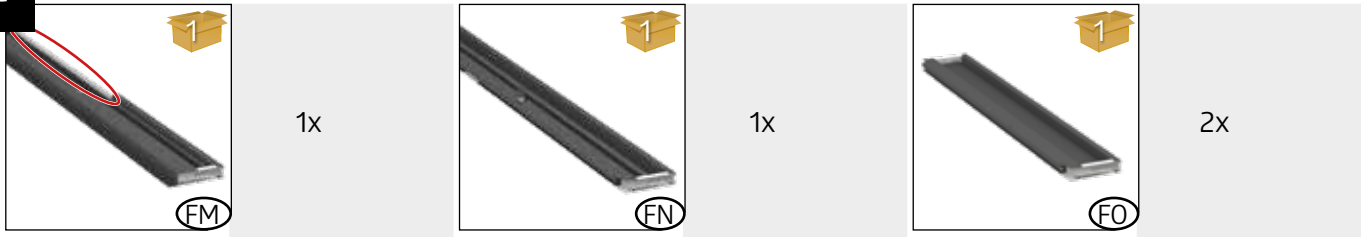

15.

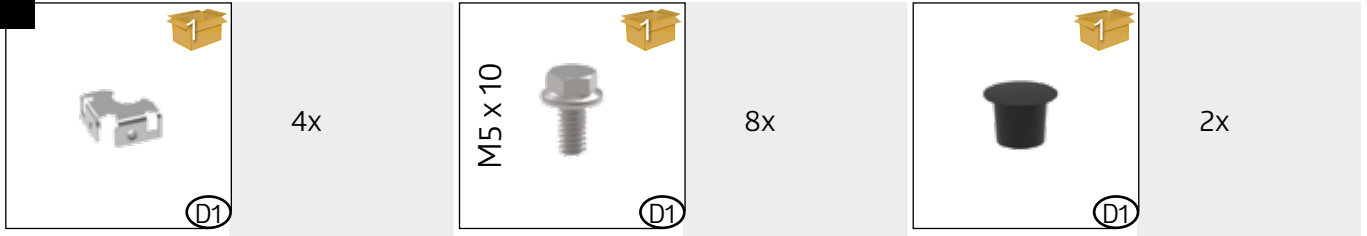

1.

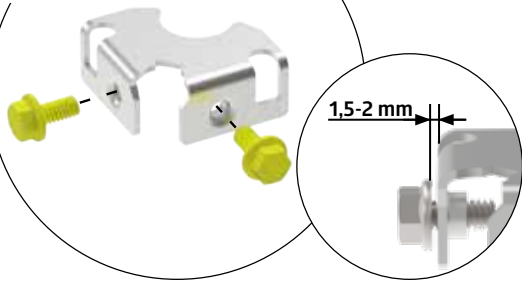

2.

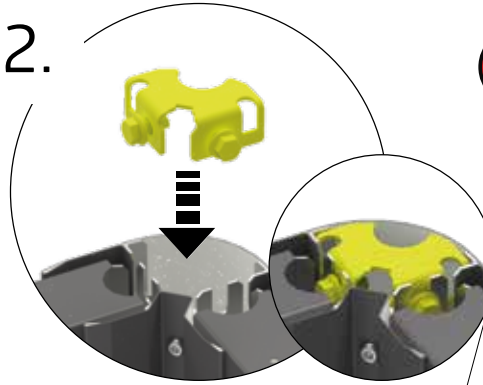

FESTZIEHEN

- ⒺⓃ tighten
- ⒻⓇ serrez fort
- ⓃⓁ vastdraaien
- ⒺⓈ apriete
- ⒾⓉ serrare a fondo
- Ⓓⓐ fastspænding
- ⓈⓋ Dra åt
- Ⓝⓞ Stramme
- ⓅⓁ Dokrećić
- ⓈⓀ Dotiahnuť
- ⓈⓁ Zategnite
- ⒸⓈ Dotáhnout
- ⒽⓊ Erősen meghúzni
- ⒽⓇ Zategnite
- Ⓡⓞ Strangeti

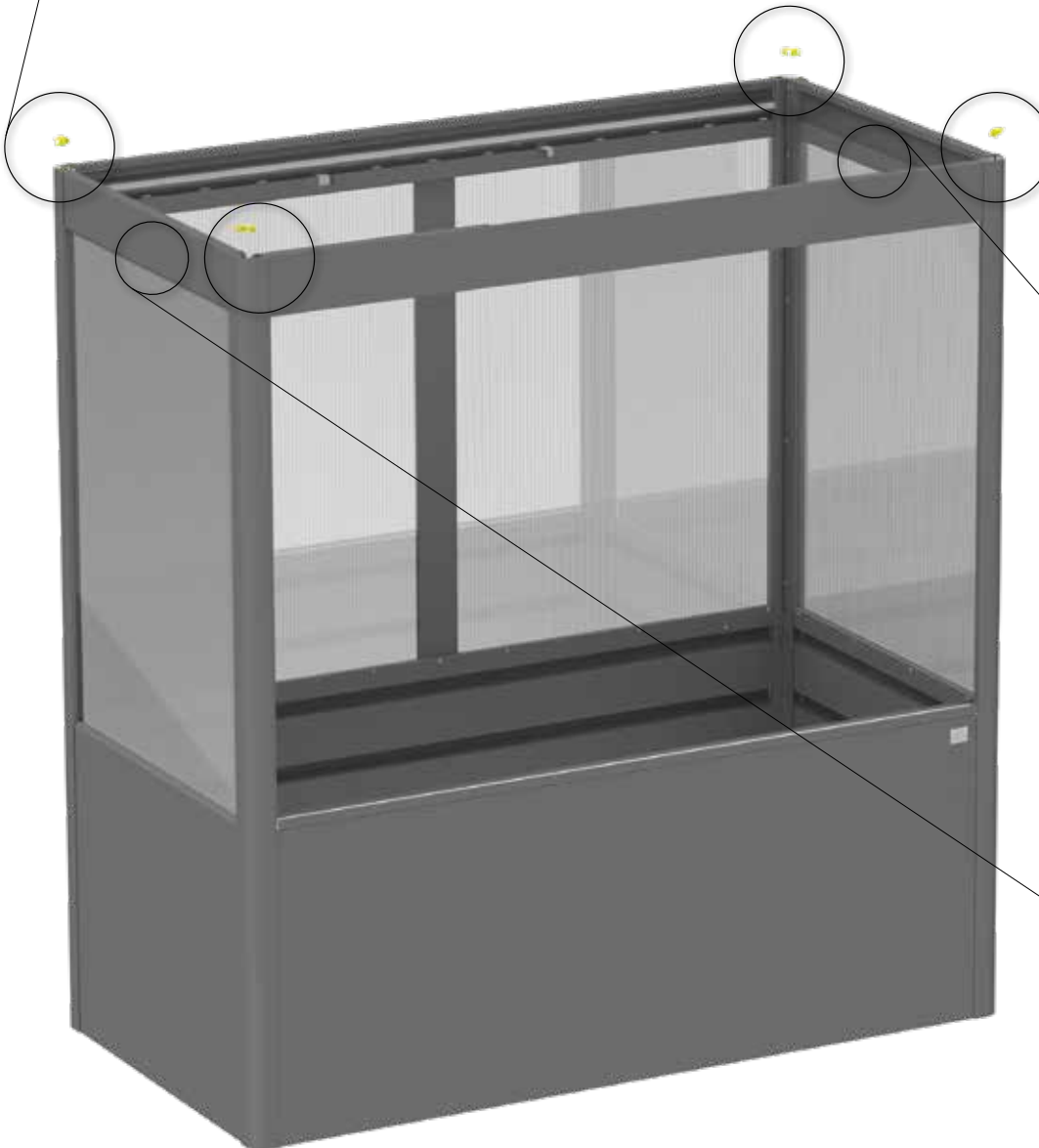

3.

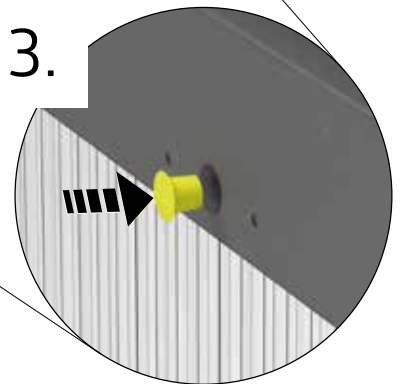

16.

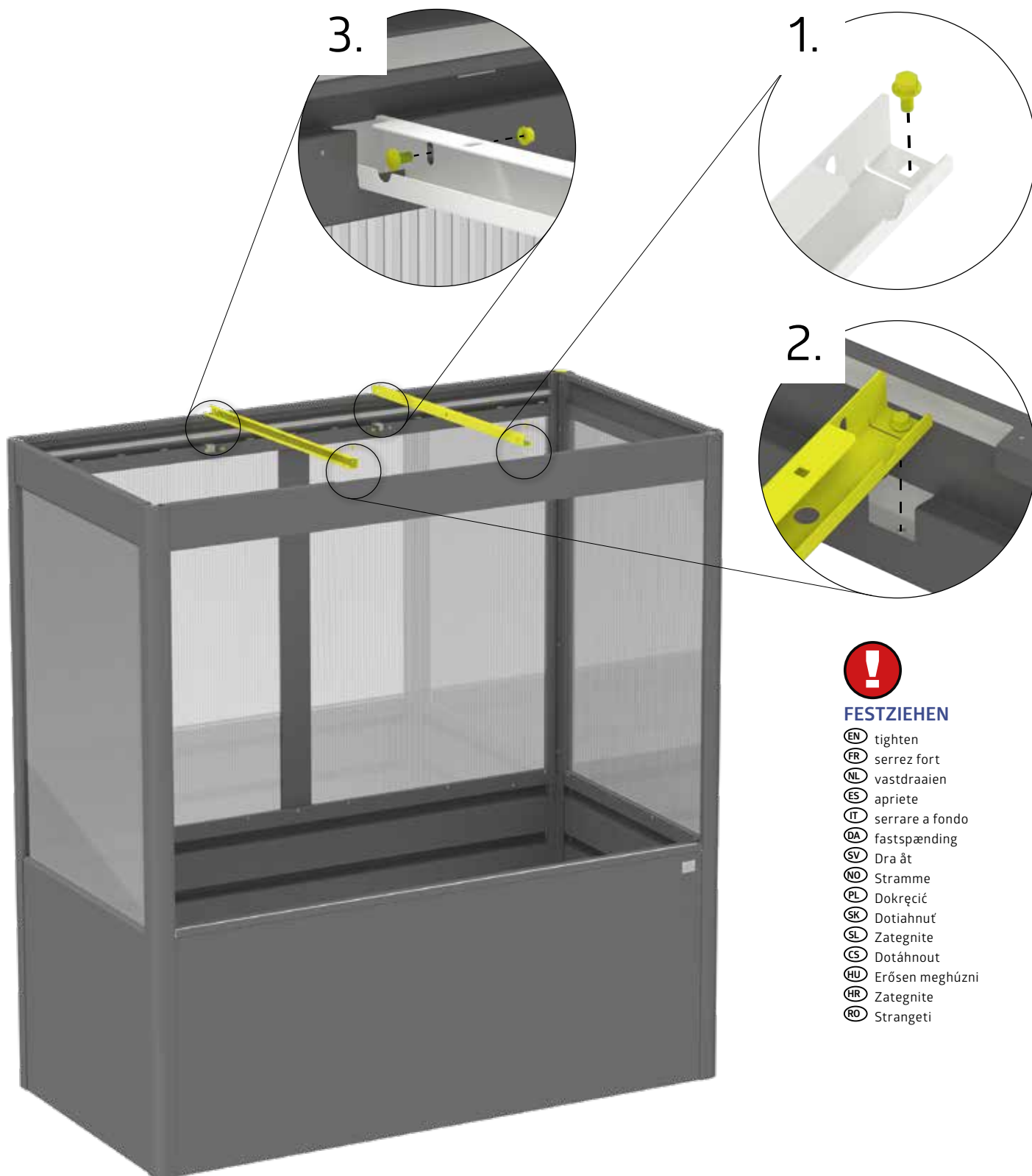
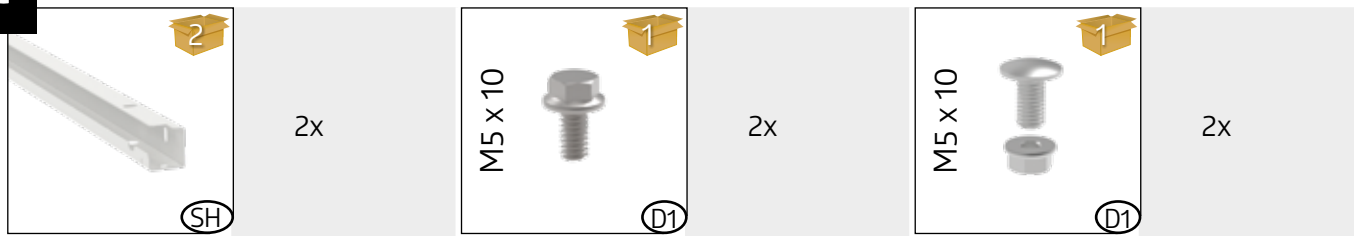

FESTZIEHEN

- EN tighten
- FR serrez fort
- NL vastdraaien
- ES apriete
- IT serrare a fondo
- DA fastspænding
- SV Dra åt
- NO Stramme
- PL Dokręcić
- SK Dotiahnuť
- SL Zategnite
- CS Dotáhnout
- HU Erősen meghúzni
- HR Zategnite
- RO Strangeti

17.

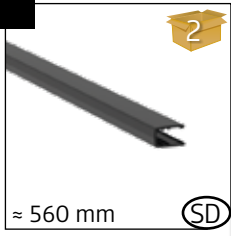
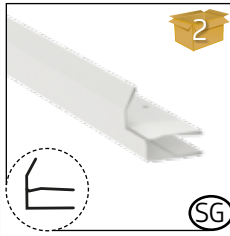
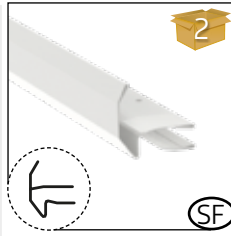
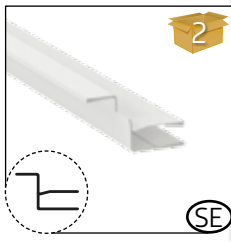
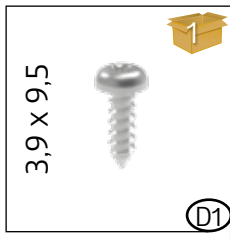
	6x		2x		2x
	2x		8x		

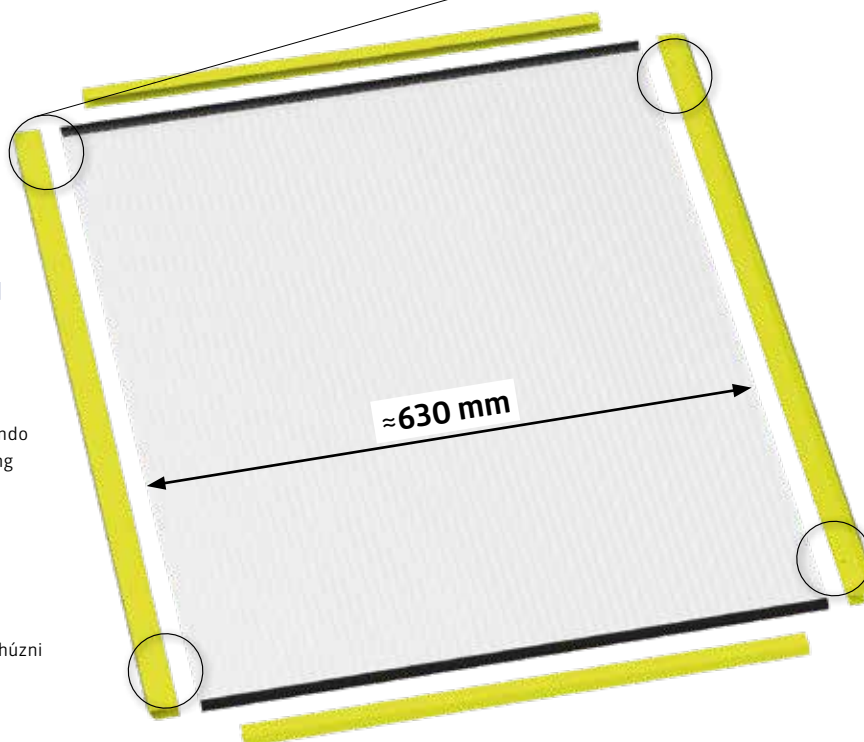
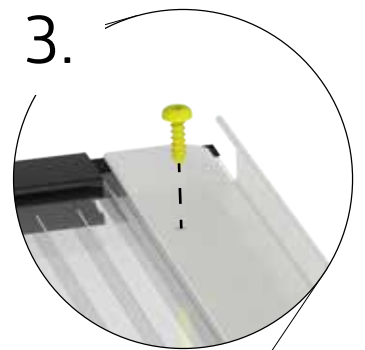
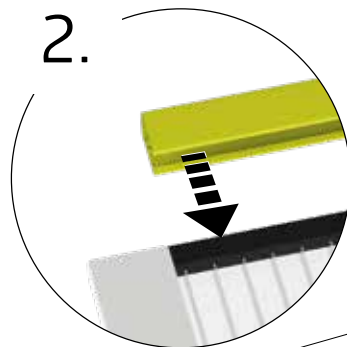
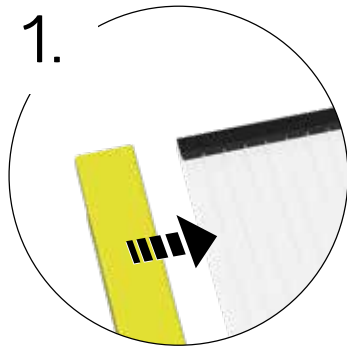

FESTZIEHEN

- Ⓔ tighten
- Ⓕ serrez fort
- Ⓖ vastdraaien
- Ⓔ apriete
- Ⓗ serrare a fondo
- Ⓓ fastspænding
- Ⓔ Dra åt
- Ⓖ Stramme
- Ⓖ Dokrećić
- Ⓔ Dotiahnuť
- Ⓔ Zategnite
- Ⓔ Dotáhnout
- Ⓔ Erősen meghúzni
- Ⓔ Zategnite
- Ⓔ Strangeti

18.

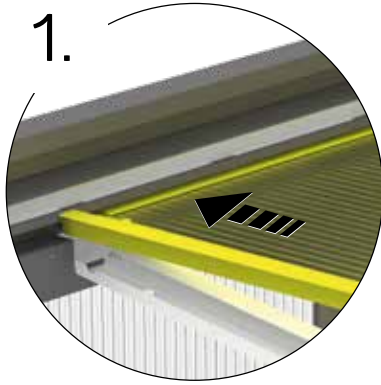
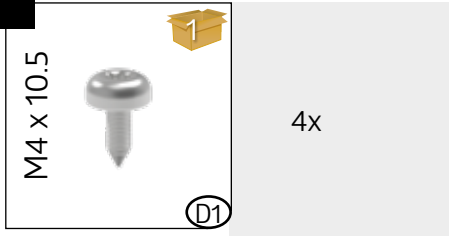

1.

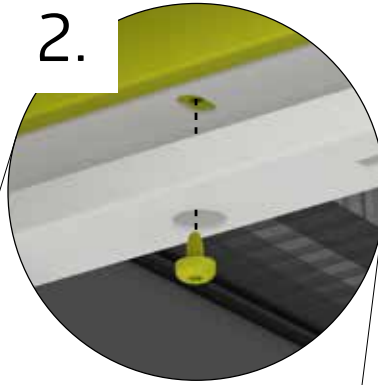

2.



FESTZIEHEN

- EN tighten
- FR serrez fort
- NL vastdraaien
- ES apriete
- IT serrare a fondo
- DA fastspænding
- SV Dra åt
- NO Stramme
- PL Dokręcić
- SK Dotiahnuť
- SL Zategnite
- CS Dotáhnout
- HU Erősén meghúzni
- HR Zategnite
- RO Strangeti

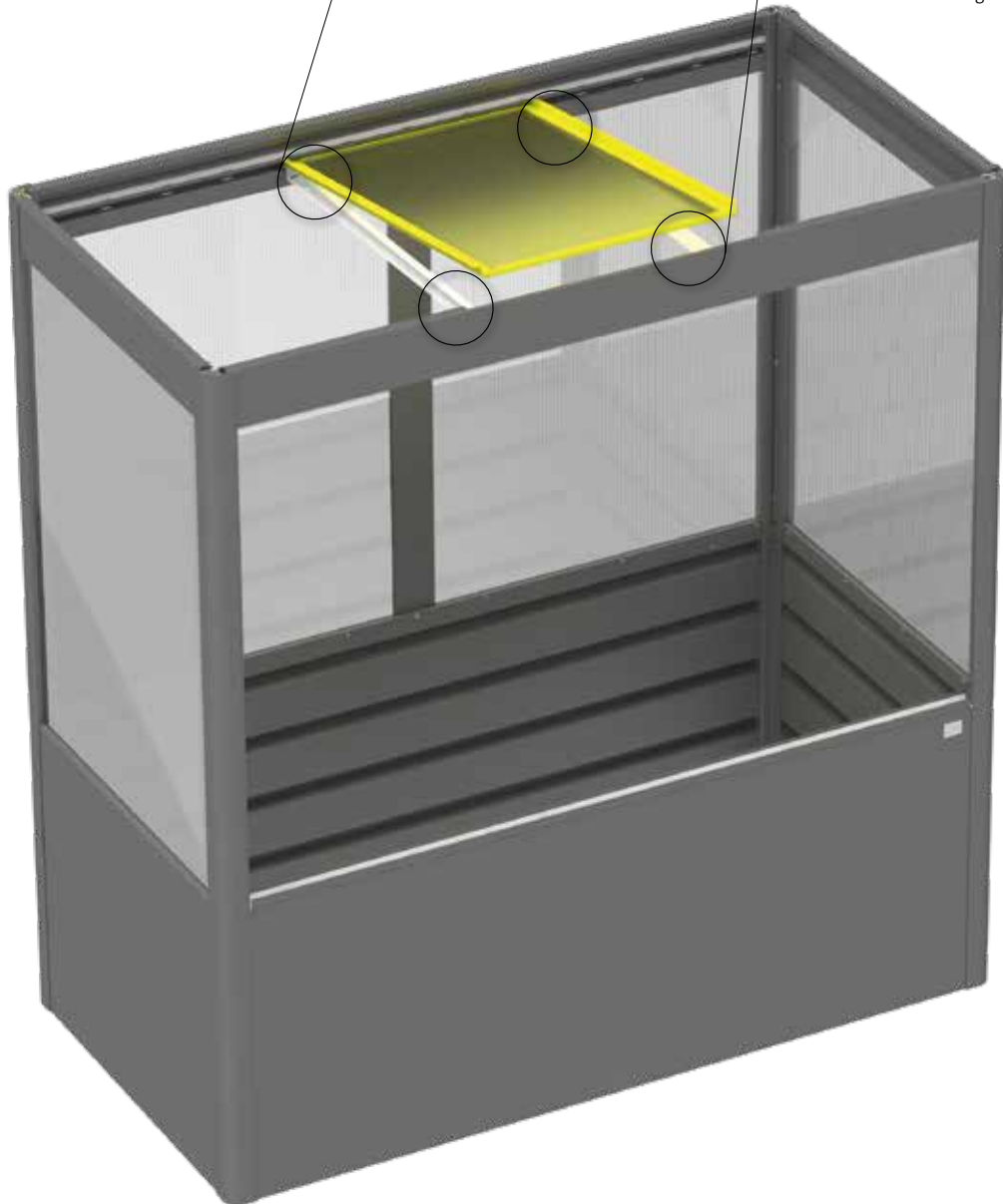

19.

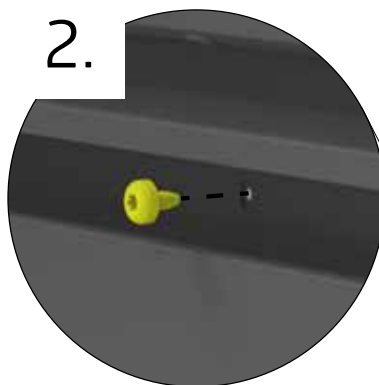
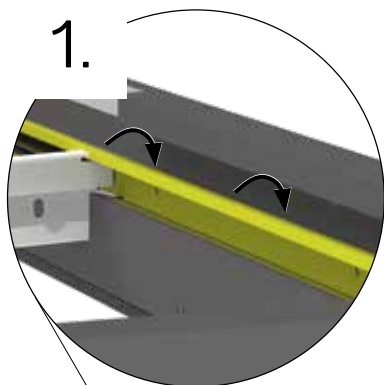

FESTZIEHEN

- (EN) tighten
- (FR) serrez fort
- (NL) vastdraaien
- (ES) apriete
- (IT) serrare a fondo
- (DA) fastspænding
- (SV) Dra åt
- (NO) Stramme
- (PL) Dokręcić
- (SK) Dotiahnuť
- (SL) Zategnite
- (CS) Dotáhnout
- (HU) Erősen meghúzni
- (HR) Zategnite
- (RO) Strangeti

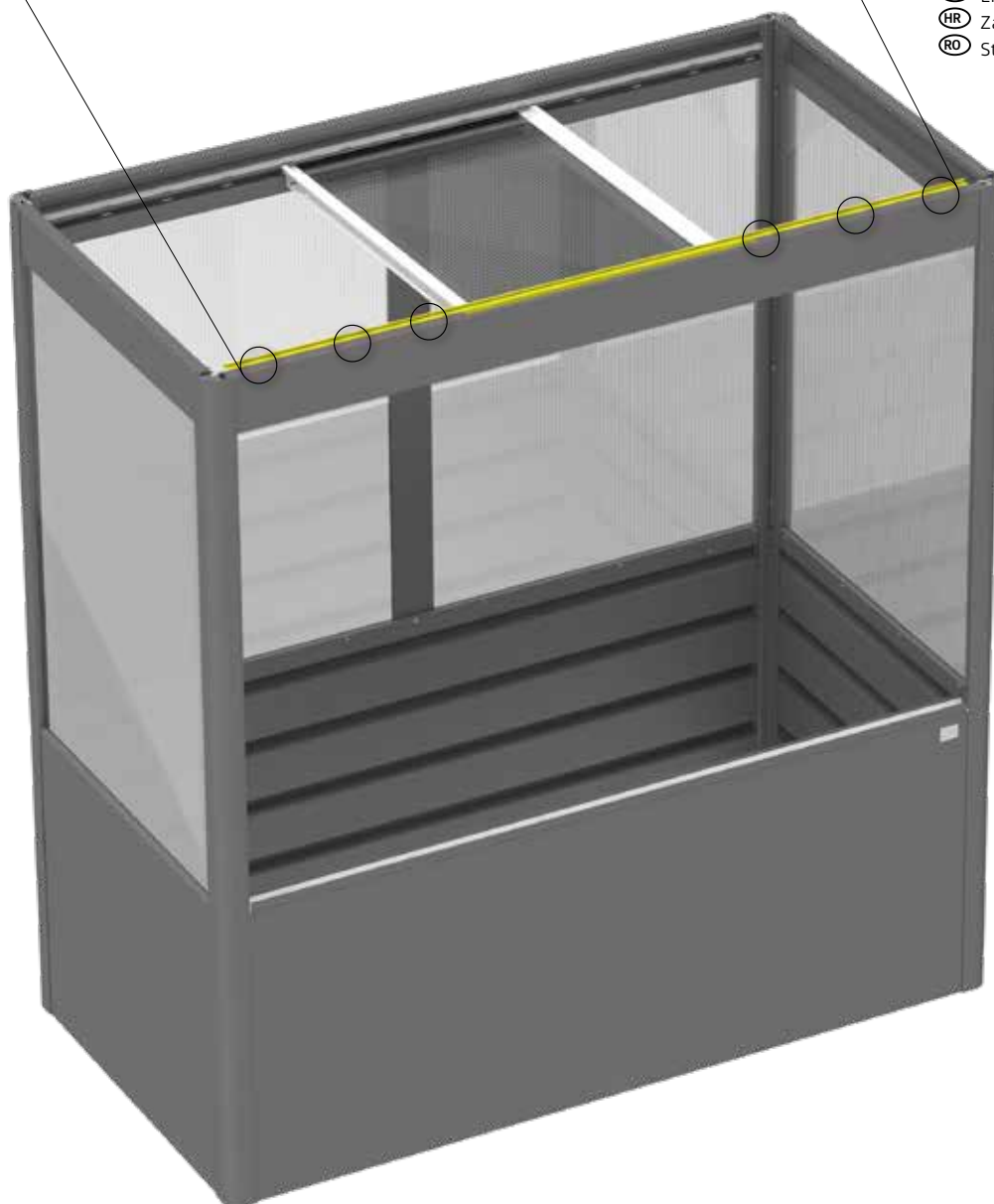

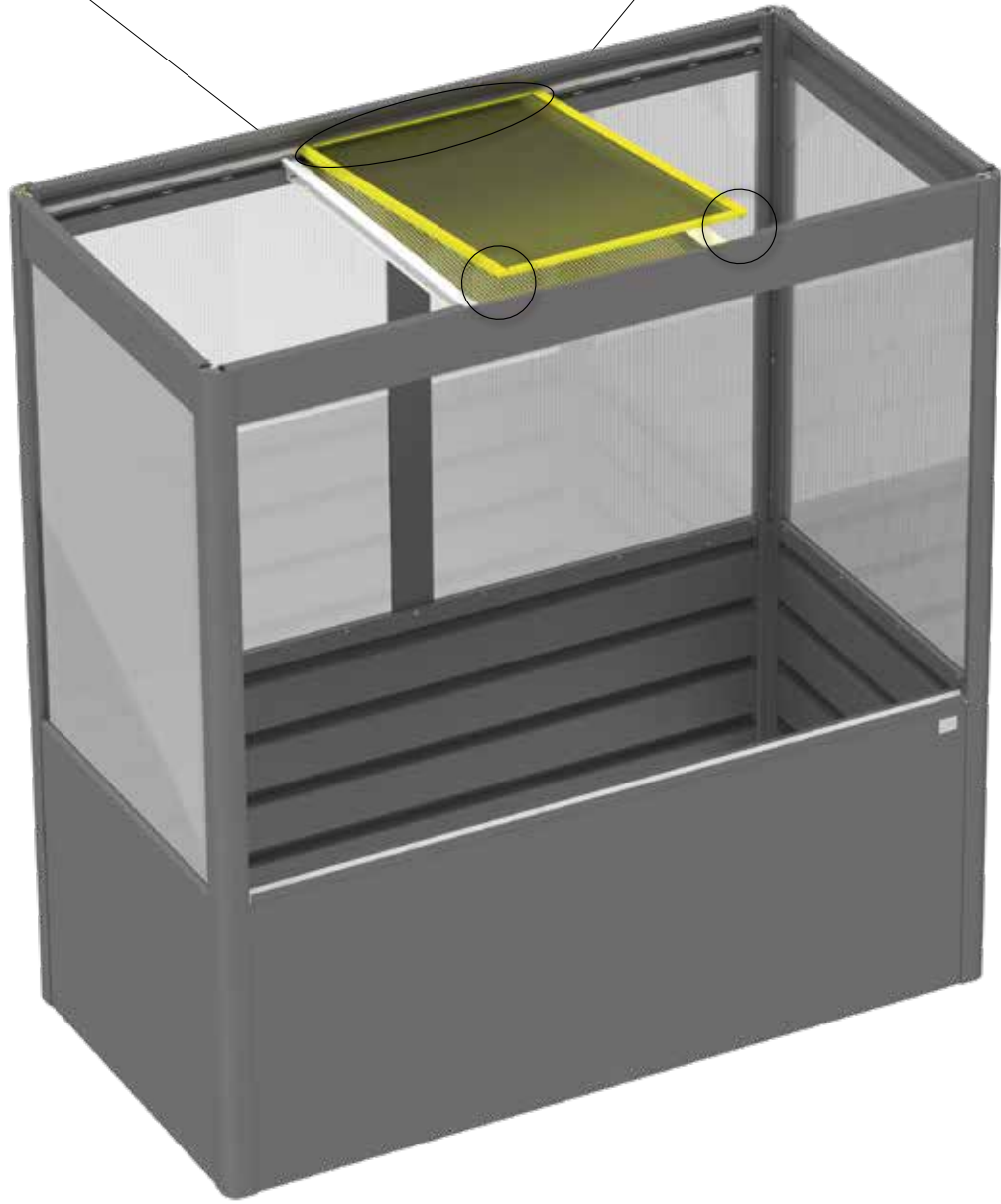
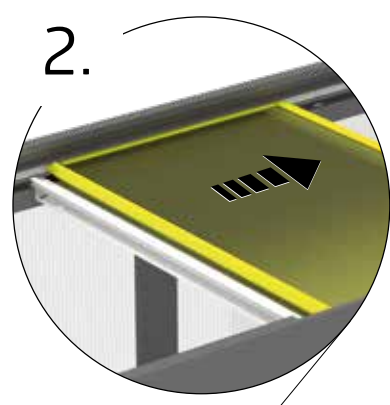
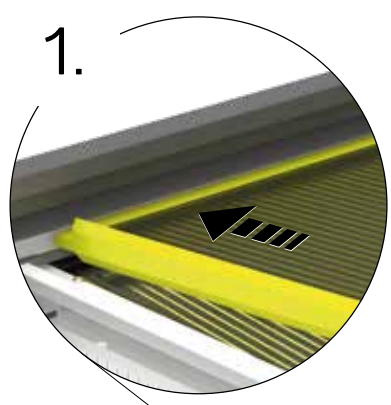

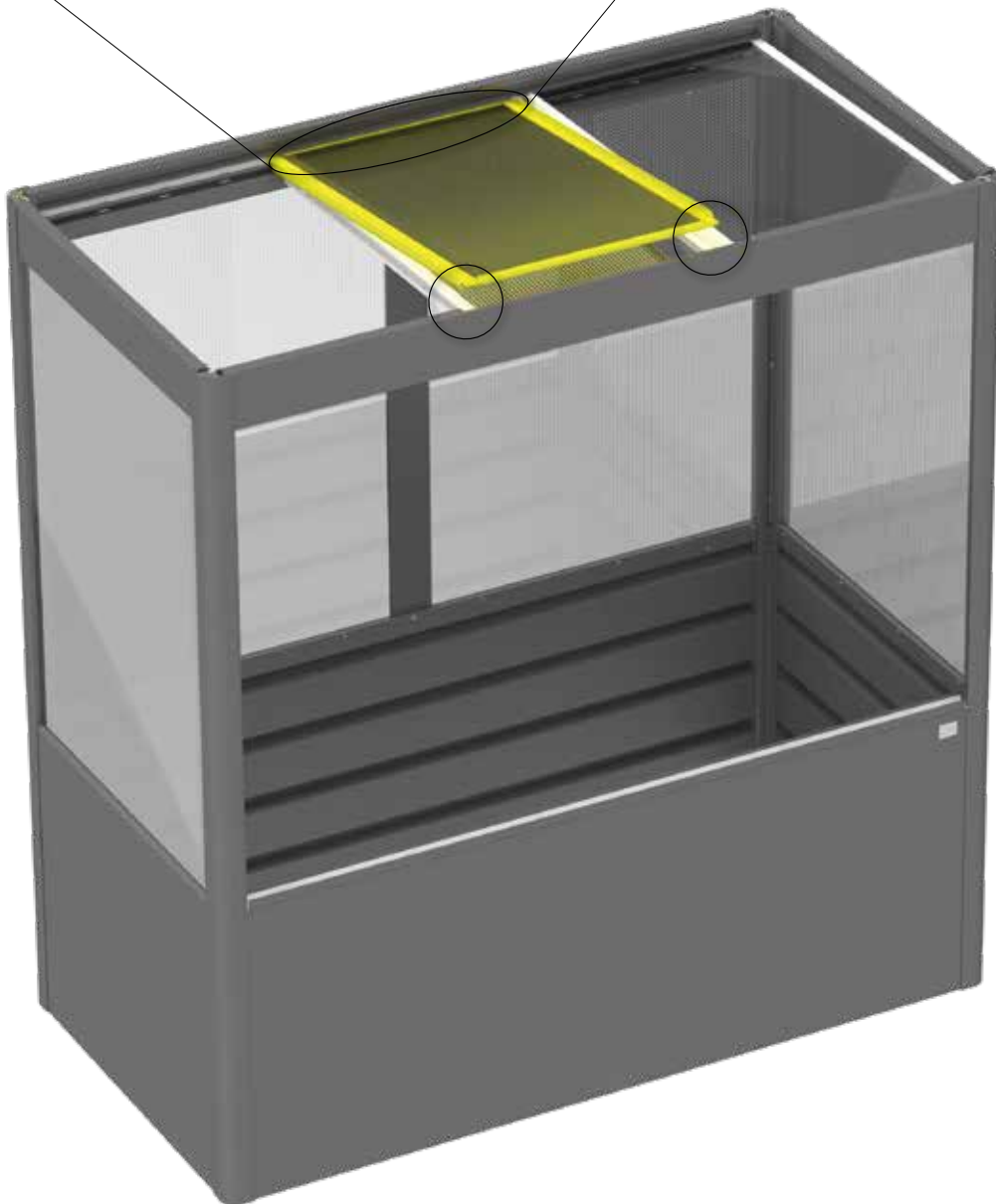
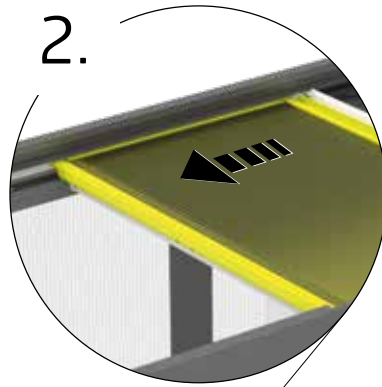
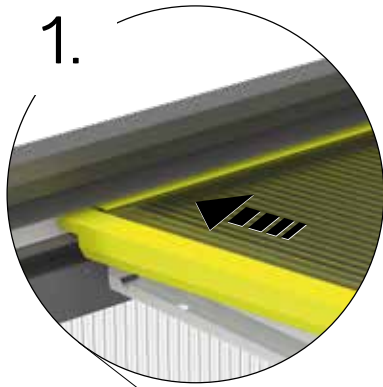

22.

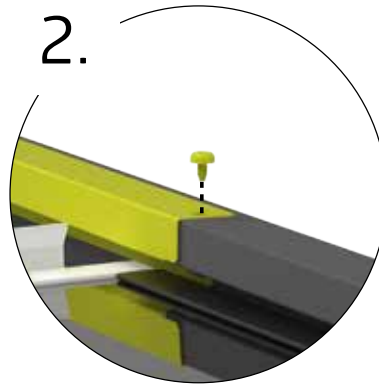
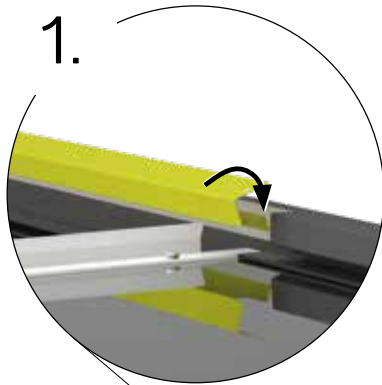

FESTZIEHEN

- (EN) tighten
- (FR) serrez fort
- (NL) vastdraaien
- (ES) apriete
- (IT) serrare a fondo
- (DA) fastspænding
- (SV) Dra åt
- (NO) Stramme
- (PL) Dokręć
- (SK) Dotiahnuť
- (SL) Zategnite
- (CS) Dotáhnout
- (HU) Erősen meghúzni
- (HR) Zategnite
- (RO) Strangeti

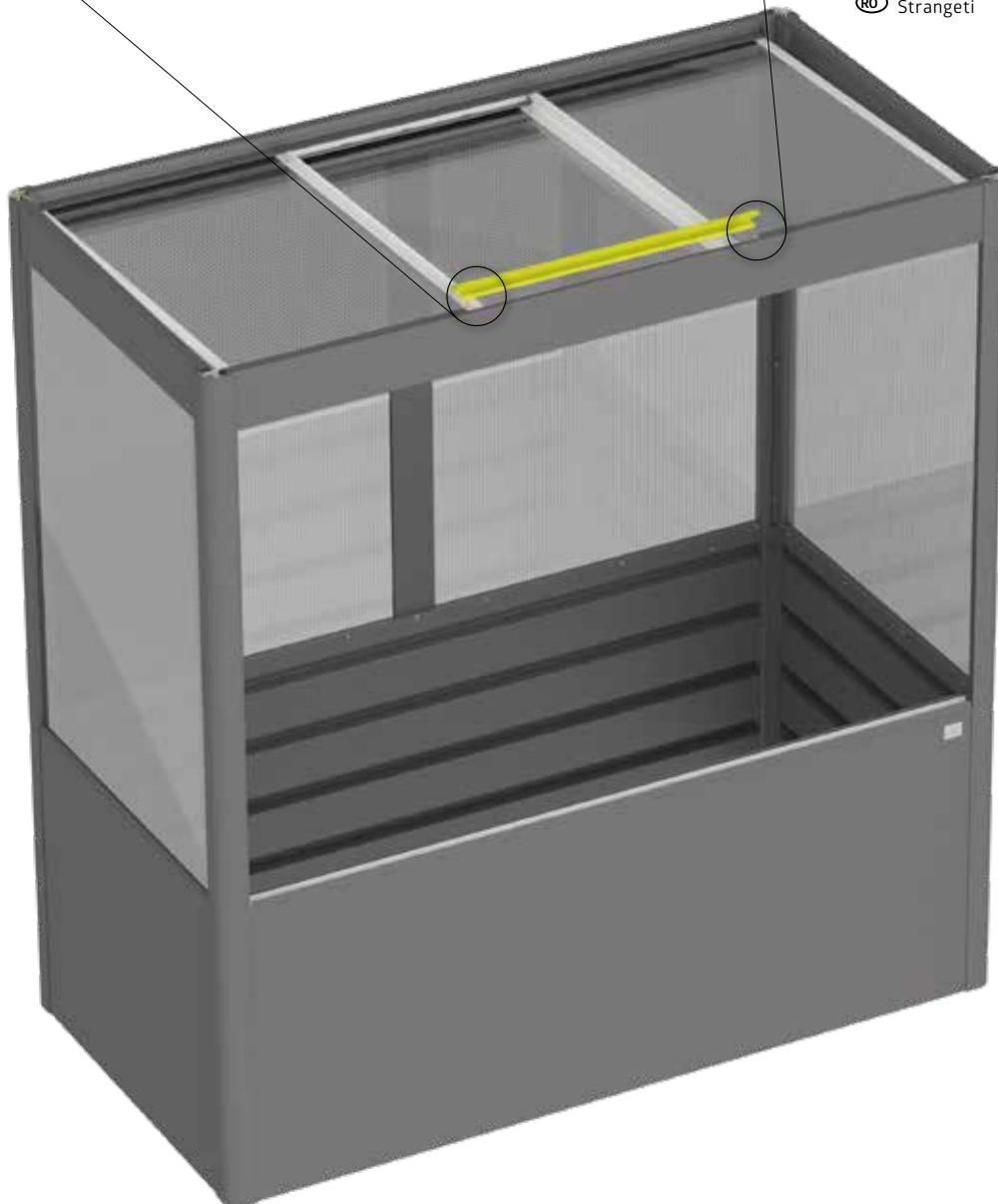

23.

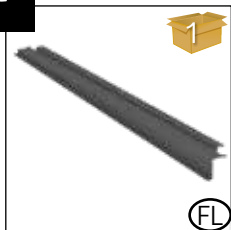

1x

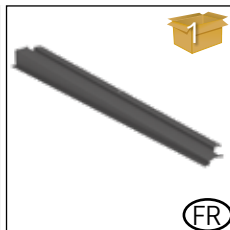

1x



M4 x 10.5

2x0,5: 4x
2x1: 6x

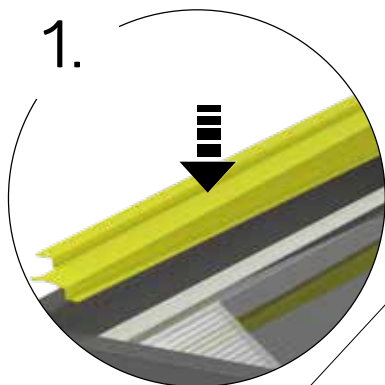

1.

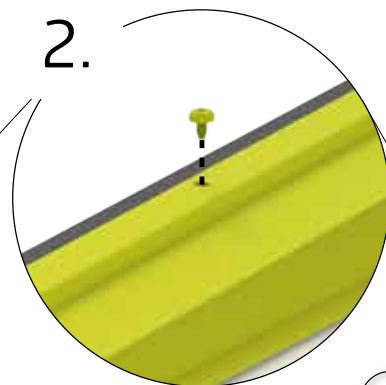

2.



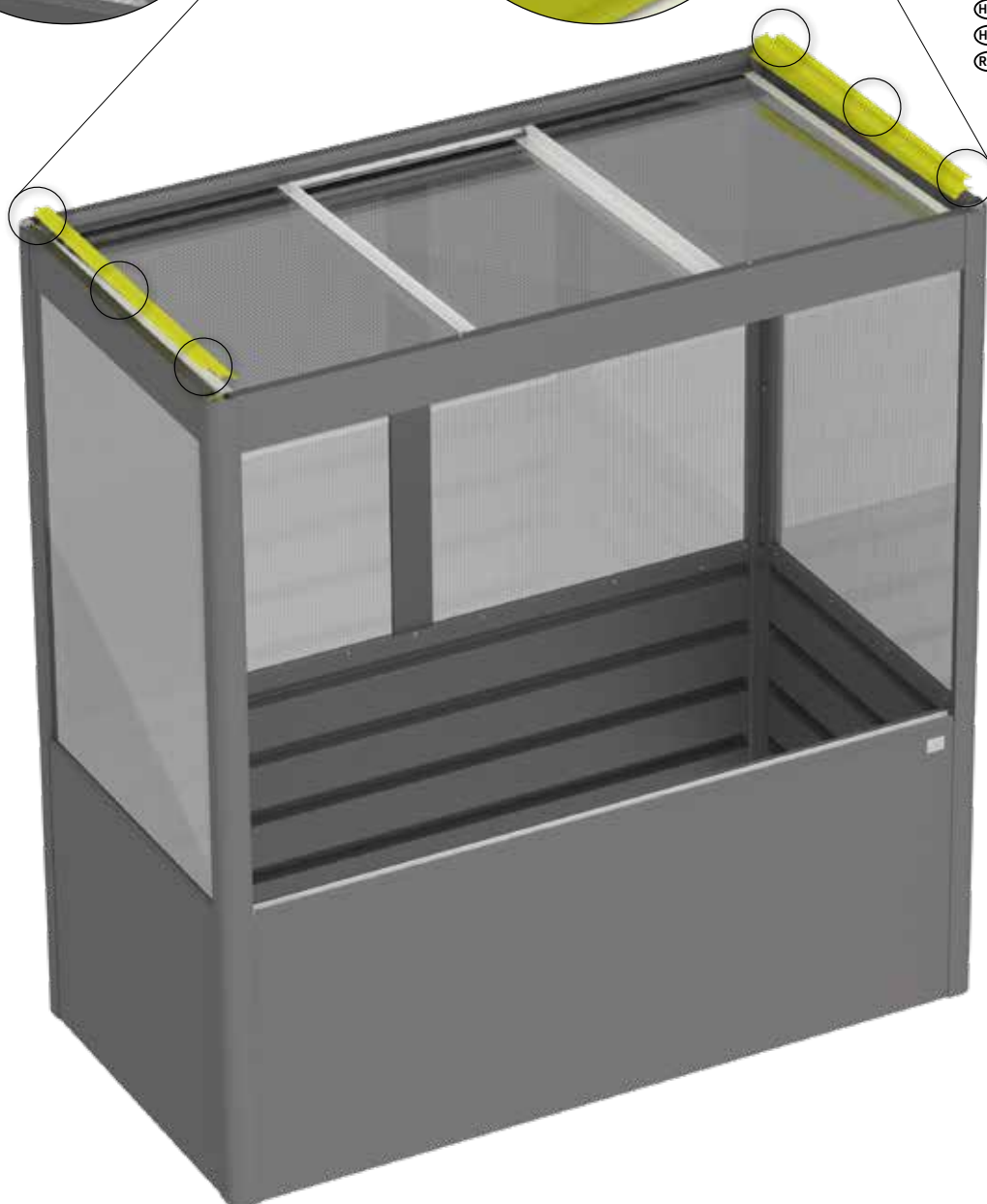

FESTZIEHEN

- (EN) tighten
- (FR) serrez fort
- (NL) vastdraaien
- (ES) apriete
- (IT) serrare a fondo
- (DA) fastspænding
- (SV) Dra åt
- (NO) Stramme
- (PL) Dokręcić
- (SK) Dotiahnuť
- (SL) Zategnite
- (CS) Dotáhnout
- (HU) Erősen meghúzni
- (HR) Zategnite
- (RO) Strangeti

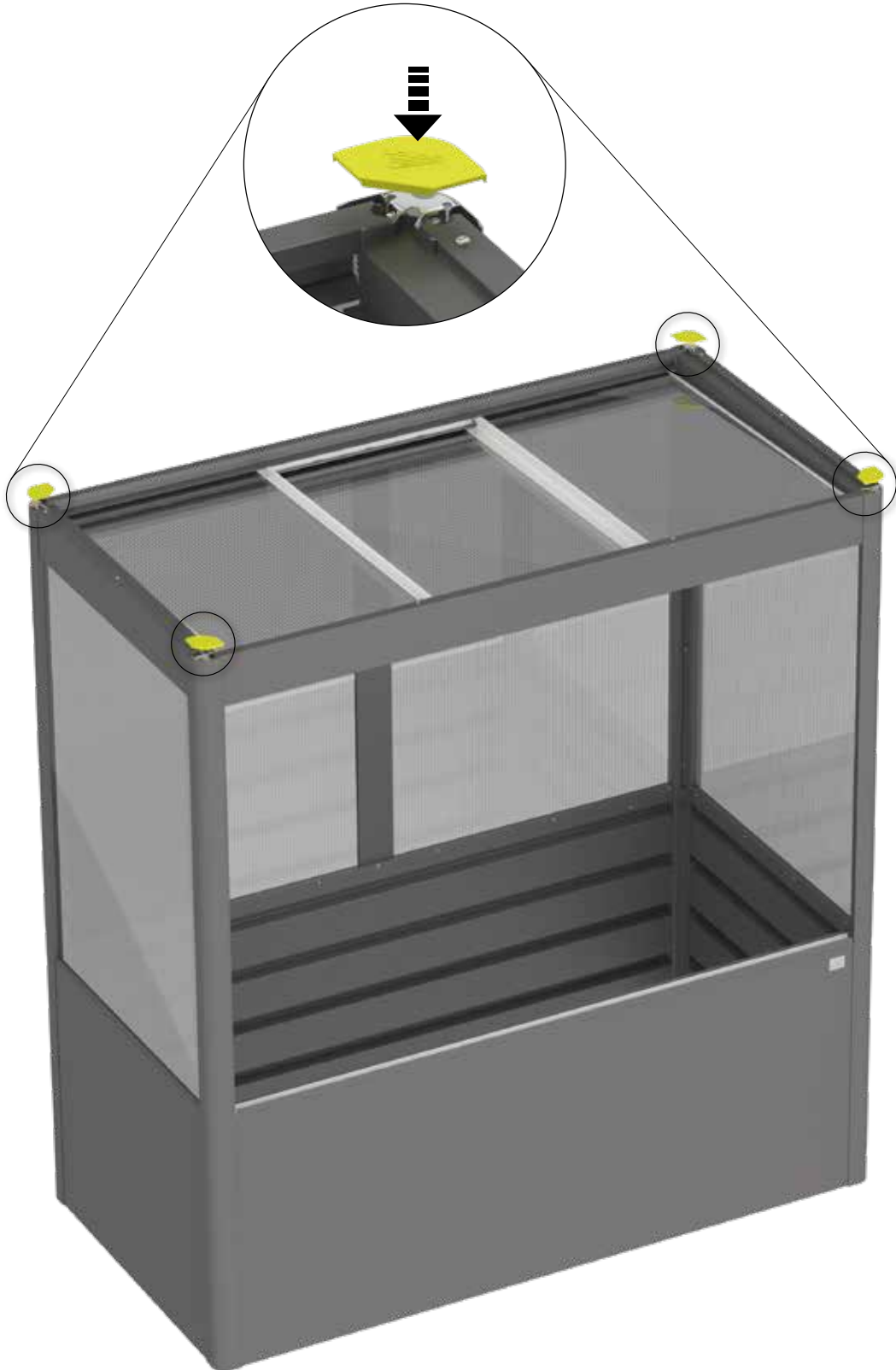
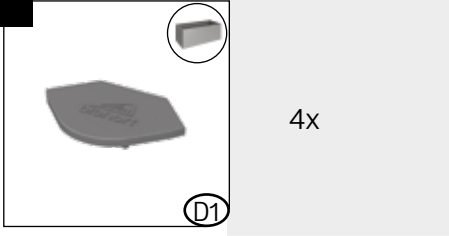

24.

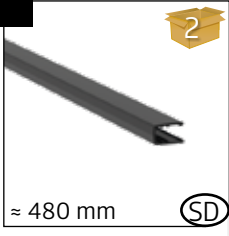
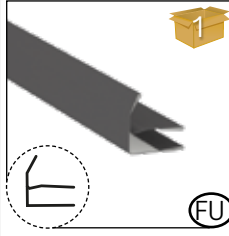
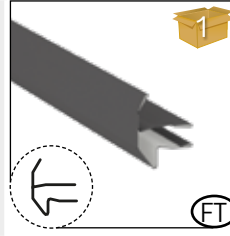

 <p>2</p> <p>~ 480 mm</p> <p>SD</p>	8x	 <p>1</p> <p>FU</p>	4x	 <p>1</p> <p>FT</p>	4x
 <p>1</p> <p>3,9 x 9,5</p> <p>D1</p>	16x				

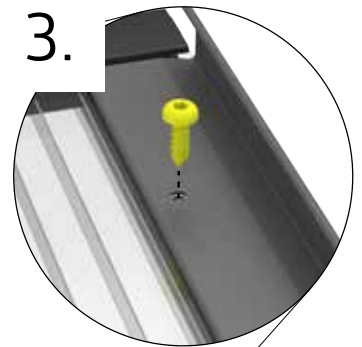
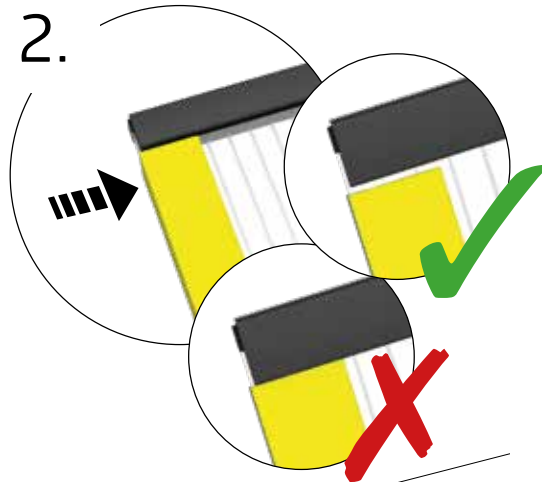
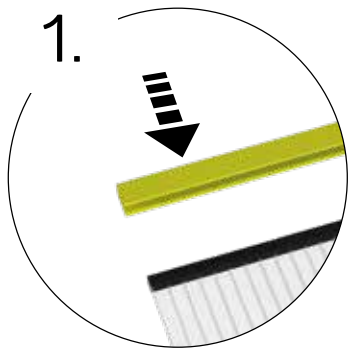

4x

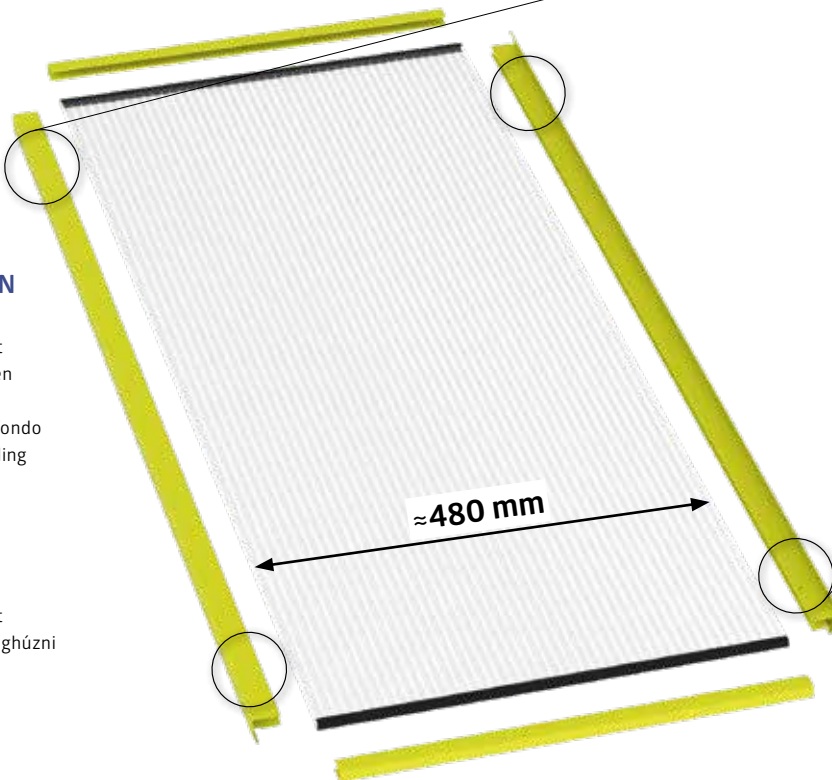

FESTZIEHEN

- Ⓔ tighten
- Ⓕ serrez fort
- Ⓖ vastdraaien
- Ⓔ apriete
- Ⓙ serrare a fondo
- Ⓓ fastspænding
- Ⓔ Dra át
- Ⓗ Stramme
- Ⓖ Dokręcić
- Ⓔ Dotiahnuť
- Ⓔ Zategnite
- Ⓔ Dotáhnout
- Ⓔ Erősén meghúzni
- Ⓔ Zategnite
- Ⓔ Strangeti



26.

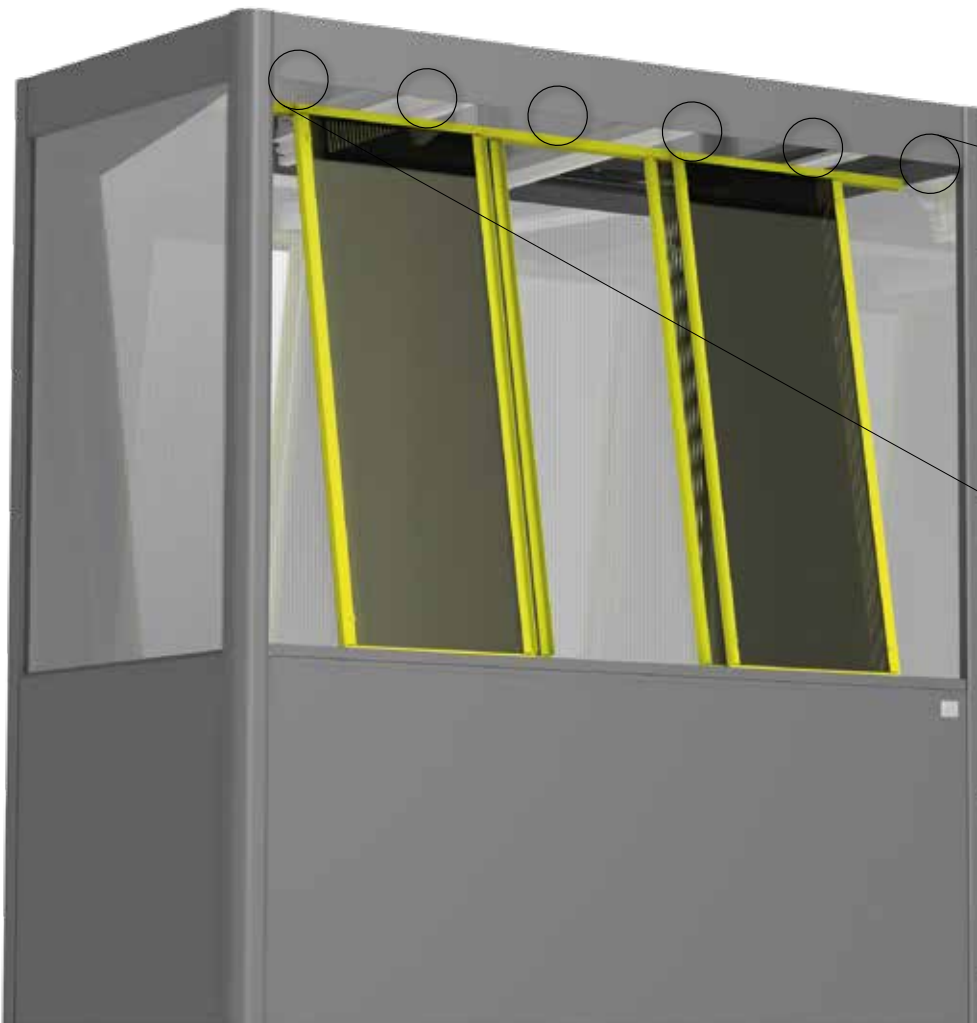
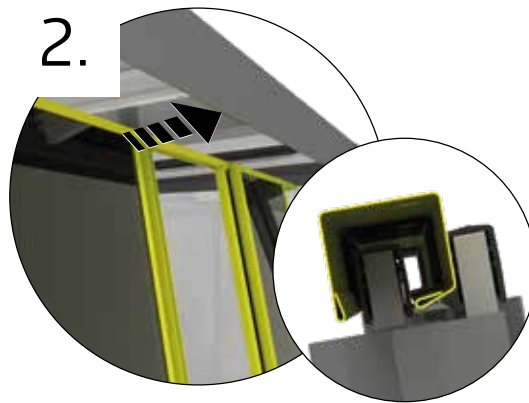
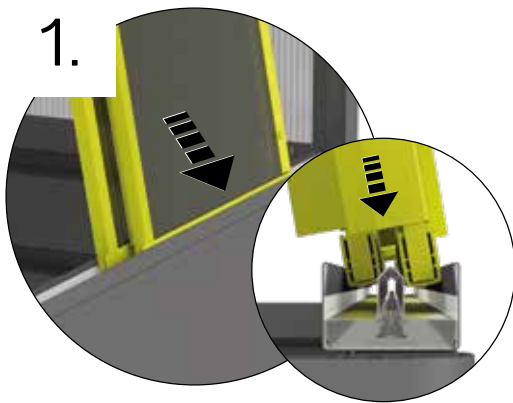
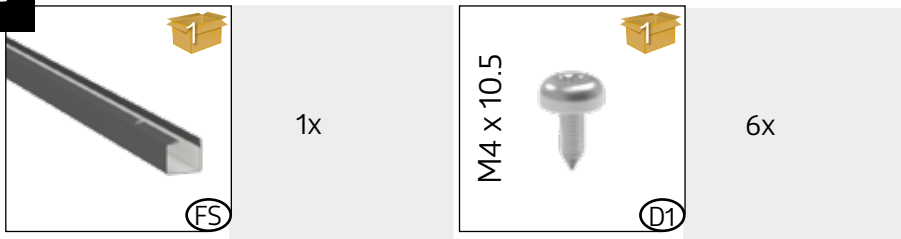

FESTZIEHEN

- (EN) tighten
- (FR) serrez fort
- (NL) vastdraaien
- (ES) apriete
- (IT) serrare a fondo
- (DA) fastspænding
- (SV) Dra åt
- (NO) Stramme
- (PL) Dokręcić
- (SK) Dotiahnuť
- (SL) Zategnite
- (CS) Dotáhnout
- (HU) Erősen meghúzni
- (HR) Zategnite
- (RO) Strangeti

27.

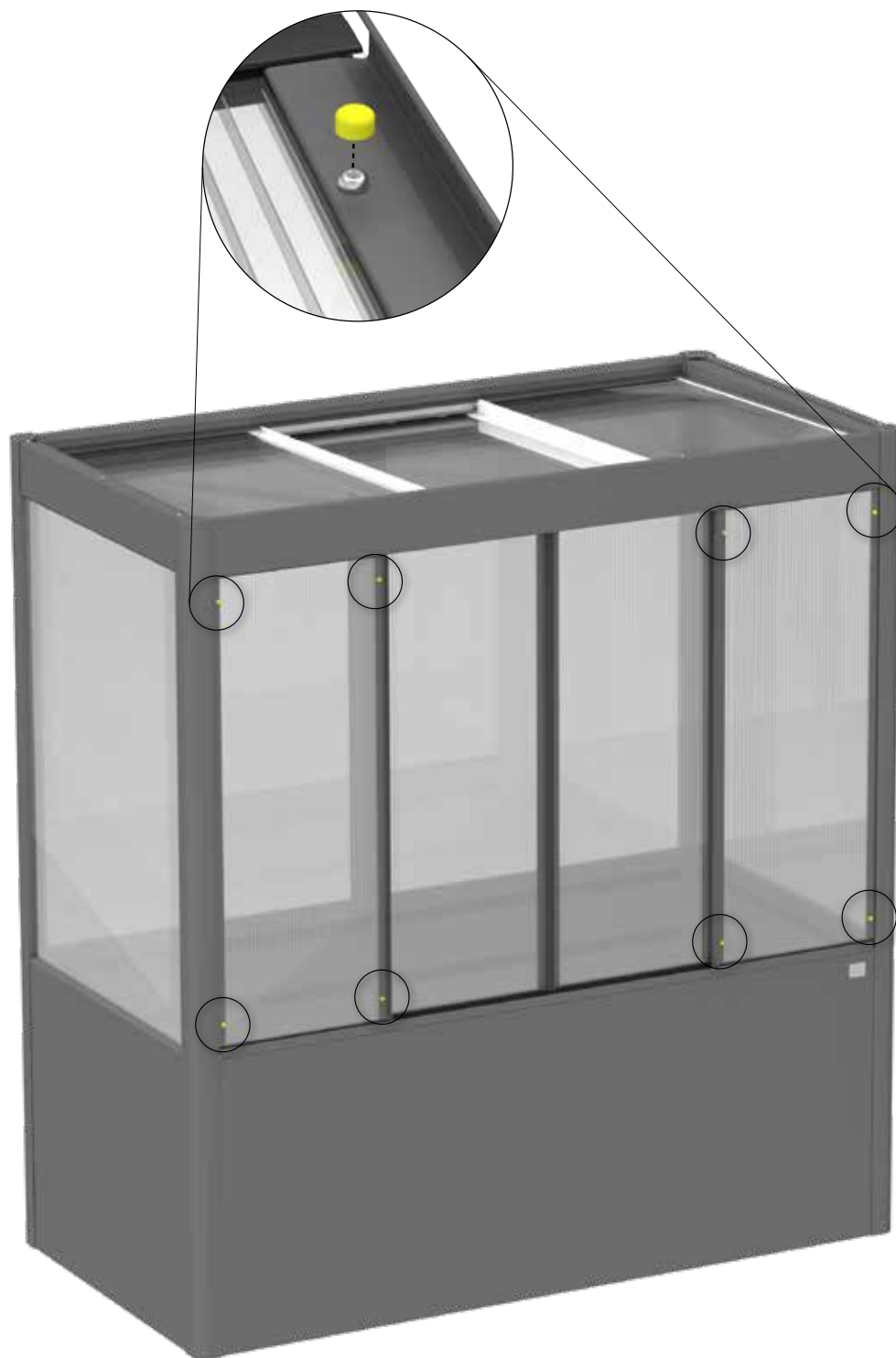
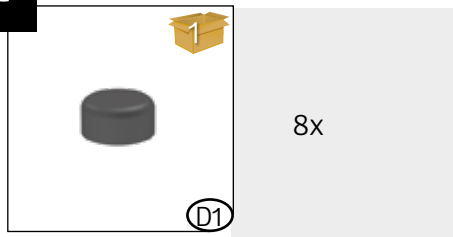

Gerätehäuser
Garden Sheds



Geräteschränke
Outdoor Lockers



Gartenboxen & Multitalente
Outdoor Boxes & Multi-Functional Storage



Outdoor Living
Outdoor Living



Gewächshäuser
Greenhouses



Pflanzbeete
Planting Beds



Gartenhelfer
Gardening Helpers



follow us:

- 📷 biohort
- 📘 biohort
- 📺 Biohort GmbH
- 📌 Biohort GmbH



Adresses sur quefairedemesdechets.fr

Biohort GmbH
PürNSTein 43, 4120
Neufelden, Österreich
+43 7282 / 7788 0
office@biohort.at
www.biohort.com