

Plus XL

V.2

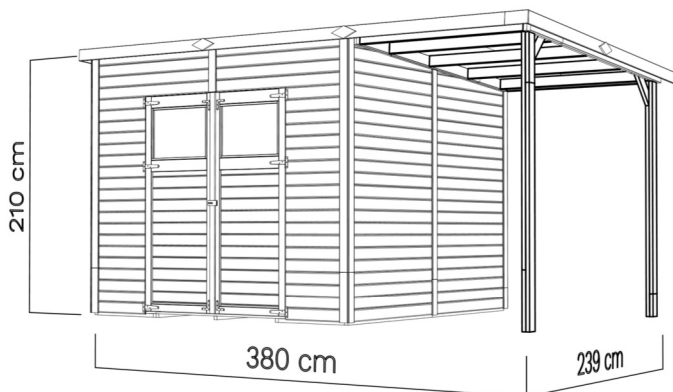

BSHPE8x8OTS

(Amrum 4 Plus)

S.S.; pp. 6-12

OTALS8x8P

(Alster 4 Plus)

S.S.; pp. 6-12

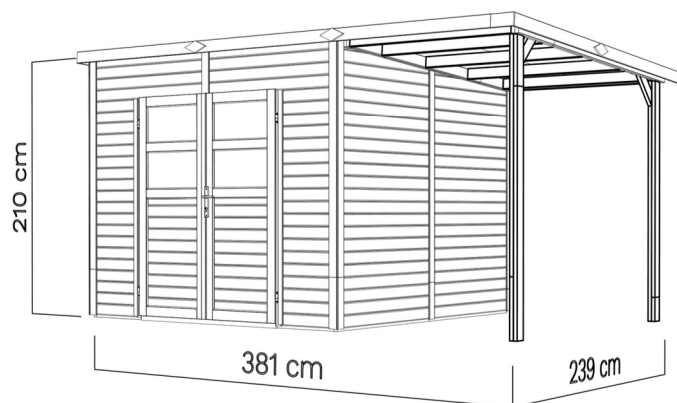
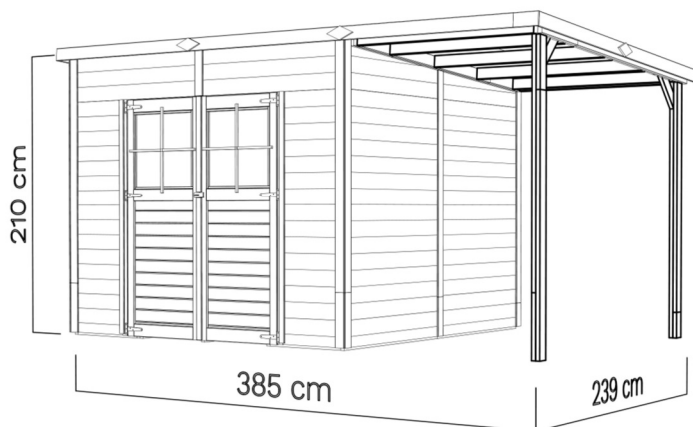

OTFEL8x8P

(Felix 3 Plus)

S.S.; pp. 6-12

OTFEL10x8P

(Felix 4 Plus)

S.S.; pp. 13-18

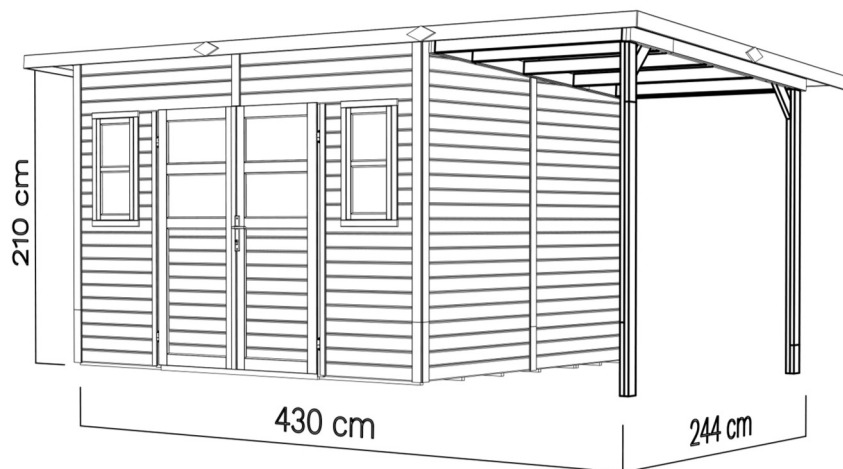

DE - Technische Änderungen vorbehalten.

Alle Maße sind ca. Maße.

EN - Technical modifications reserved.

All dimensions are approximate dimensions.

Plus XL

DE **Bevor Sie beginnen**

• Es ist empfehlenswert sich etwas Zeit zu nehmen, um die Aufbauanleitung anzusehen, bevor mit dem Aufbau begonnen wird. • Alle Schritte für den Aufbau werden – auch in Detailbildern – dargestellt. • Die vorgegebene Reihenfolge ist zu beachten. • Bitte prüfen Sie vor dem Aufbau anhand der Teileliste die Vollständigkeit und den Zustand der Lieferung. • Besonders wichtig ist der Holzschutz! Die Boden-elemente sind vor dem Aufbau von unten mit einem geeigneten Holzschutz zu behandeln! • Das für die meisten Produkte online verfügbare Datenblatt bietet weitere wichtige Hinweise für den Aufbau. • Beigefügt sind auch die Garantiebedingungen.

FR **Avant de commencer**

• il est recommandé de prendre le temps de lire les instructions de montage avant de commencer. • Toutes les étapes du montage sont présentées, y compris sur des illustrations détaillées. • L'ordre prescrit doit être respecté. • Avant le montage, vérifiez l'exhaustivité et l'état de la livraison à l'aide de la liste des pièces. • La protection du bois est particulièrement importante! Avant le montage, les éléments de plancher doivent être traités par le bas avec un produit de protection du bois approprié! • La fiche technique disponible en ligne pour la plupart des produits fournit d'autres informations importantes pour le montage. • Les conditions de garantie y sont également jointes.

CZ **Než začnete**

• Doporučujeme, abyste si vzali trochu času k prohlédnutí montážního návodu, než s montáží začnete. • Všechny montážní kroky jsou zobrazeny - také na podrobných obrázcích. • Je nutné dodržovat uvedený postup. • Před montáží zkontrolujte podle seznamu dílů, zda jste obdrželi všechny díly a zda je dodávka v dobrém stavu. • Obzvláště důležitá je dřevěná botka! Podlahové prvky musí být před montáží zespoda ošetřeny vhodným ochranným přípravkem na dřevo! • Datový list, který je k dispozici online pro většinu produktů, poskytuje další důležité pokyny k montáži. • V příloze naleznete také záruční podmínky.

DK **Før du starter**

• Det kan anbefales at tage sig tid til at kigge på samlevejledningen, før du starter samlingen. • Alle trin i samlingen bliver vist – også i detaljerede billeder. • Overhold den angivne rækkefølge. • Kontrollér, at leveringen er fuldstændig og i den rette tilstand ved hjælp af delelisten, før du starter samlingen. • Særligt vigtig er træbeskyttelsen! Gulvelementerne skal behandles med egnede træbeskyttelse nedefra, før du starter samlingen! • Til de fleste produkter kan du finde datablade online, der indeholder yderligere vigtige informationer til samlingen. • Garantibetingelserne er også vedlagt.

NL **Voordat u begint**

• Het is aan te bevelen om de tijd te nemen om de opbouwhandleiding door te nemen voordat er met het opbouwen wordt begonnen. • Alle stappen voor het opbouwen worden - ook met gedetailleerde afbeeldingen - weergegeven. • Neem de aangegeven volgorde in acht. • Controleer voor het opbouwen aan de hand van de onderdelenlijst de volledigheid en de hoedanigheid van de levering. • Bijzonder belangrijk is de bescherming van het hout! De vloerelementen moeten voor het opbouwen van anderen met een geschikt houtbeschermingsmiddel worden behandeld! • Het voor de meeste producten online beschikbare gegevensblad bevat verdere belangrijke aanwijzingen voor de opbouw. • Bijgevoegd zijn ook de garantiebepalingen.

PL **Przed rozpoczęciem**

• Wskazane jest, aby przed przystąpieniem do montażu zapoznać się z instrukcją montażu. • Pokazane są wszystkie etapy montażu – również na szczegółowych zdjęciach. • Należy przestrzegać podanej kolejności. • Przed montażem należy skorzystać z listy części, aby sprawdzić, czy dostawa jest kompletna i w dobrym stanie. • Ochrona drewna jest szczególnie ważna! Przed montażem elementy podłogowe należy zabezpieczyć od dołu odpowiednim środkiem do konserwacji drewna! • Arkusz danych, który jest dostępny online dla większości produktów, zawiera dalsze ważne informacje dotyczące montażu. • Załączone są również warunki gwarancji.

SV **Innan du börjar**

• Vi rekommenderar att du åsidosätter lite tid för att titta igenom monteringsanvisningen innan du påbörjar monteringen. • Alla monteringsstegen visas – även med detaljerade bilder. • Den angivna ordningen måste följas. • Kontrollera att leveransen är komplett och i gott skick innan monteringen påbörjas med hjälp av listan över delar. • Träskyddet är av yttersta vikt! Golvelementen ska behandlas underifrån med lämpligt träskyddsmedel före monteringen! • Annan viktig information före montering finns i databladet (tillgängligt online för de flesta produkter). • Garantivillkoren bifogas också.

RO **Înainte să începeți**

• Vă recomandăm să dedicați puțin timp pentru a consulta Instrucțiunile de asamblare înainte de a începe asamblarea. • Toate etapele de asamblare sunt prezentate amănunțit - și în forma unor figuri detaliate. • Respectați ordinea specificată. • Înainte de asamblare, vă rugăm să verificați lista de componente pentru a vă asigura că furnitura este completă și în stare bună. • Acordați o deosebită atenție protecției lemnului! Elementele de podea trebuie tratate de dedesubt cu o substanță conservantă adecvată pentru protecția lemnului înainte de asamblare! • Fișa de date, care este disponibilă și online pentru majoritatea produselor, oferă informații suplimentare importante cu privire la asamblare. • Atașat veți găsi și condițiile de garanție.













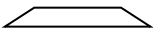



EE **Soovitused enne paigalduse alustamist**

• Soovitame enne paigalduse alustamist võtta aega ja tutvuda paigaldusjuhendiga. • Kõik kokkupaneku etapid on näidatud ka üksikasjalikel piltidel. • Paigaldustööd tuleks teha etteantud järjekorras. • Enne paigalduse alustamist kontrollige detailide nimekirja alusel, kas kõik elemendid on olemas ja ega need pole kahjustada saanud. • Puidukaitse on eriti oluline! Põrandaelemente tuleb enne kokkupanekut töödelda altpoolt sobiva puidukaitsevahendiga! • Andmeleht, mis on enamiku toodete kohta internetis saadaval, pakub kokkupanekuks täiendavat olulist teavet. • Lisatud on ka garantiitingimused.

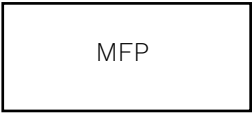
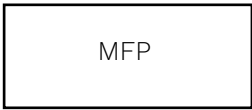
EN **Before assembly**

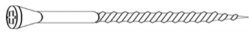
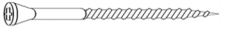
• We recommend that time is taken to read the assembly instructions prior to assembly. • All assembly steps are shown – also in detailed images. • The step-by-step instructions must be followed. • Before assembly, please use the parts list to check that all components are accounted for and in good condition. • Wood protection is particularly important! The floor elements must be treated from below with a suitable wood preservative before assembly! • The data sheet, which is available online for most products, offers further important information for assembly. • The guarantee conditions are also attached.

Plus XL

ID	Details in mm (Tolerance/Toleranz ...+ 2mm)	Pcs.	ID	Details in mm (Tolerance/Toleranz ...+ 2mm)	Pcs.
2028	28 x 80 x 1286 	x 6			
932	28 x 80 x 1650 	x 8			
2030	28 x 80 x 840  	x 2	2032	28 x 80 x 1300 	x 1
2031	28 x 80 x 609 	x 4	938	28 x 28 x 1430 	x 2
939	12 x 90 x 1430 	x 1	628	12 x 90 x 201 	x 1
516	12 x 830 x 1150 	x 2	940	12 x 595 x 1150 	x 2
2029	12 x 230 x 595 	x 2	678	12 x 280 x 830 	x 2
1502	Ø5 x 120 	x 28	1505	Ø4,5 x 90 	x 8
1502	Ø4,5 x 70 	x 4	1505	Ø4,5 x 50 	x 76
1506	Ø3,5 x 35 	x 110			

Plus XL

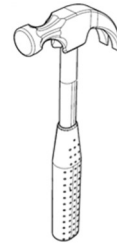
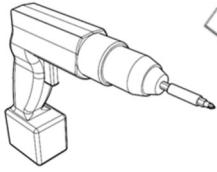

Ø 4 mm

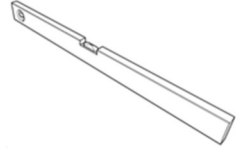
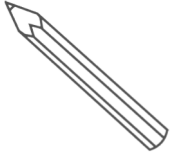

1.

OTFEL8x8P
OTFEL10x8P
BSHPE8x8OTS
OTALS8x8P

2.

Plus XL

3.

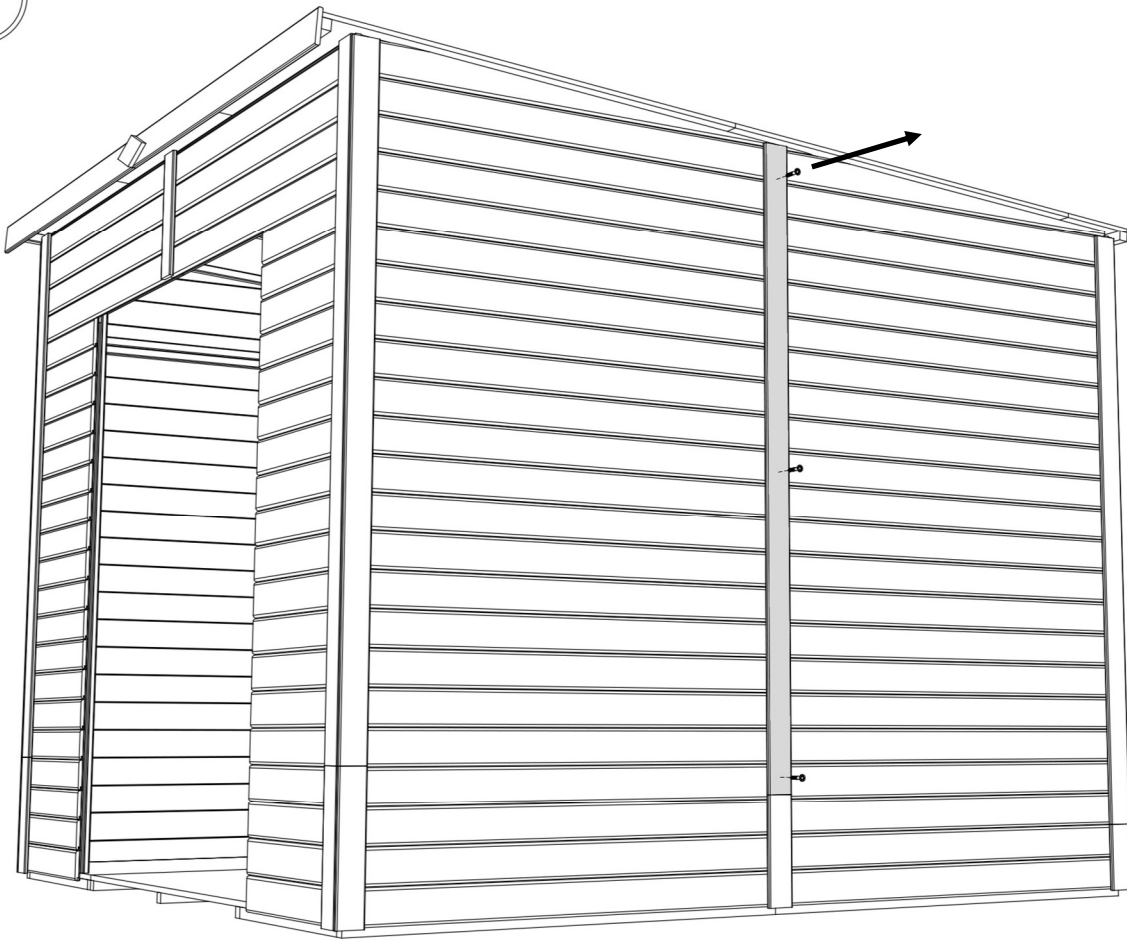

4.

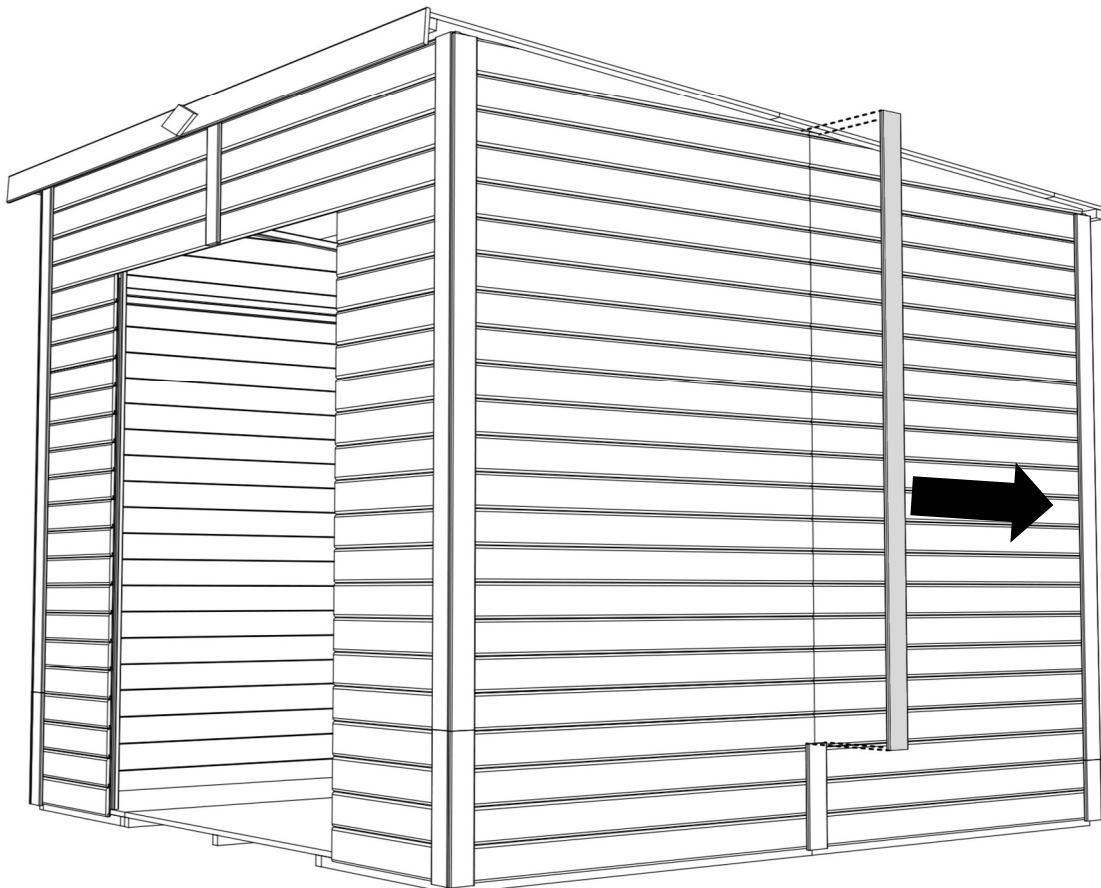

Plus XL

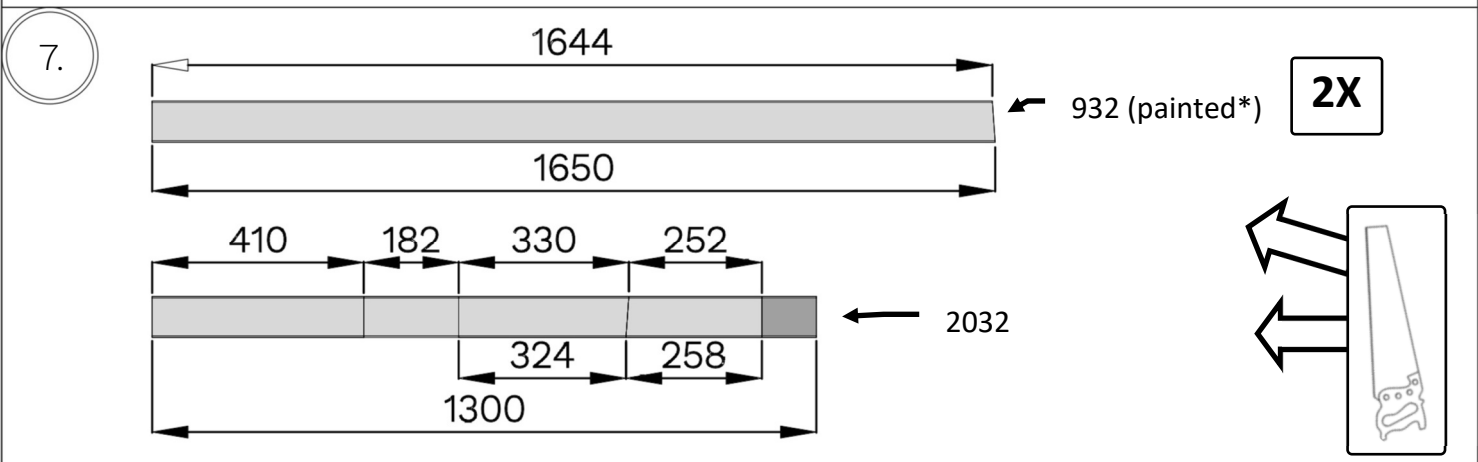
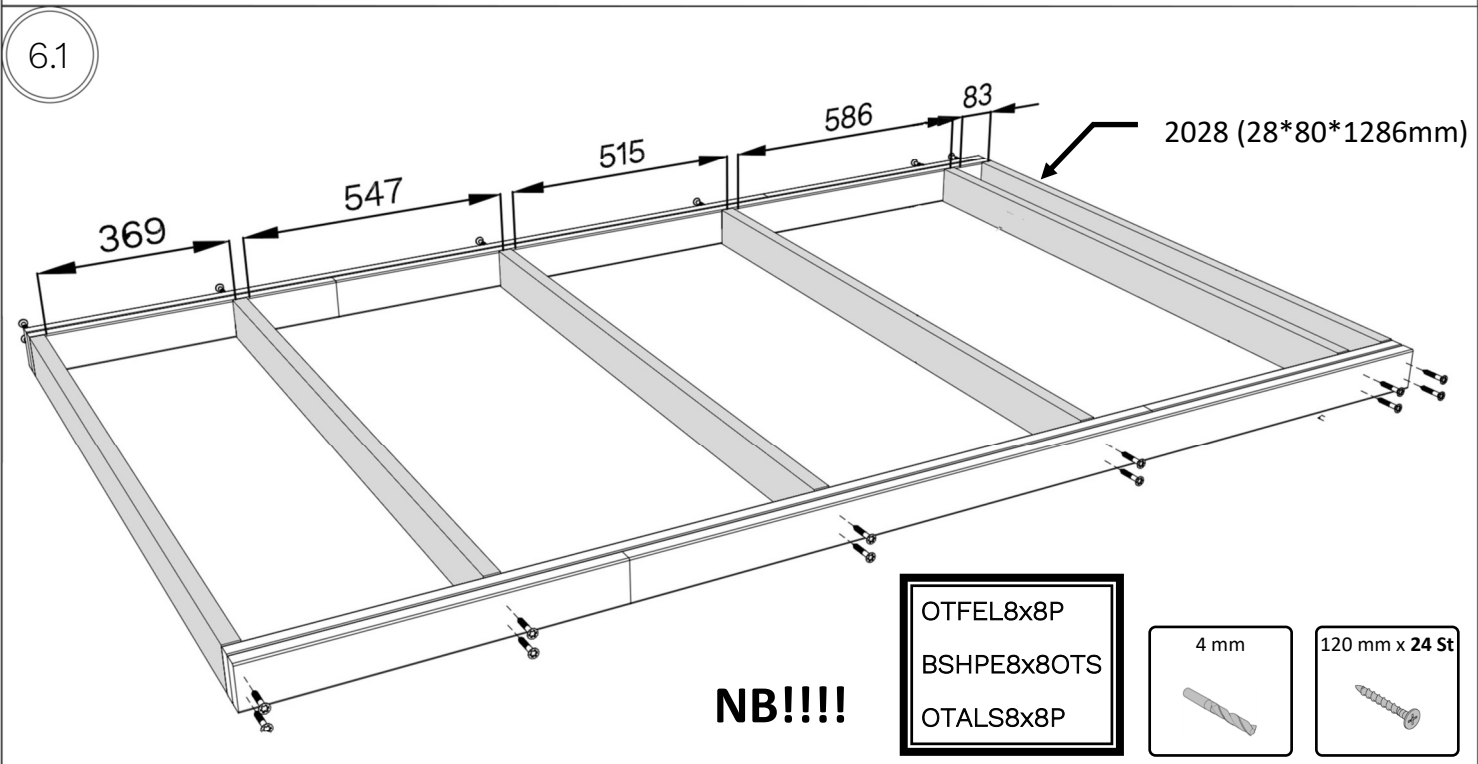
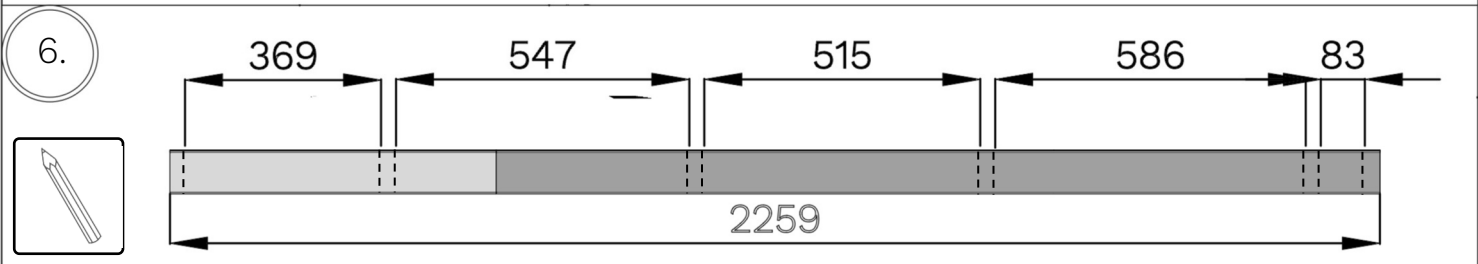
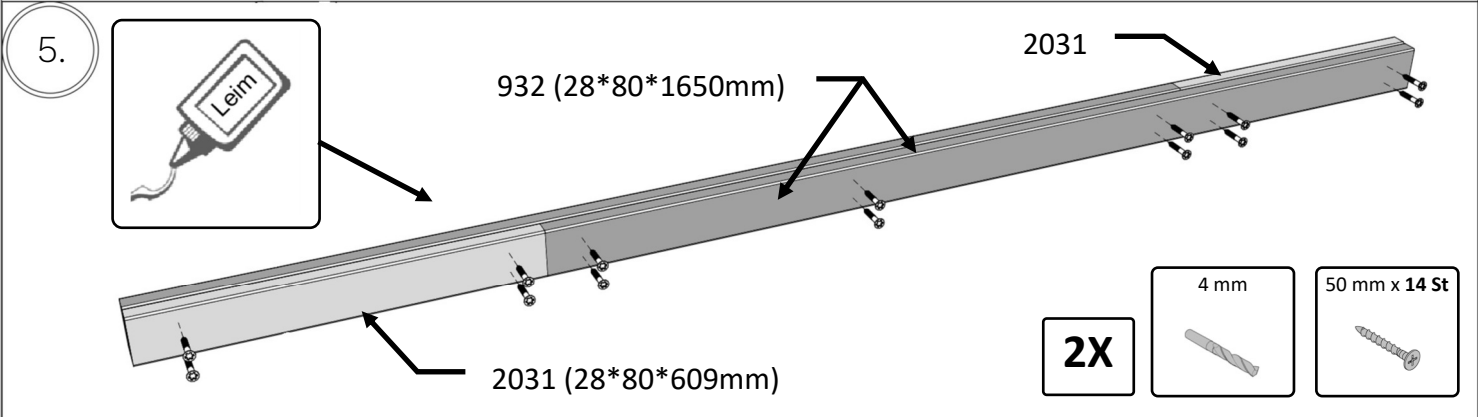

Plus XL

8.

4 mm



50 mm x 18 St



(28*80*330mm)

932

932

2060 mm

1650 mm

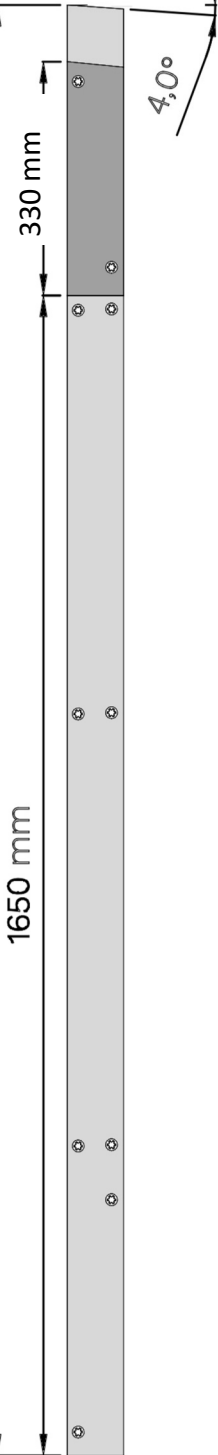

(28*80*410mm)

9.

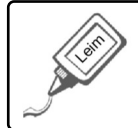

4 mm

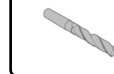

50 mm x 18 St



(28*80*258mm)

932

932

1908 mm

1650 mm

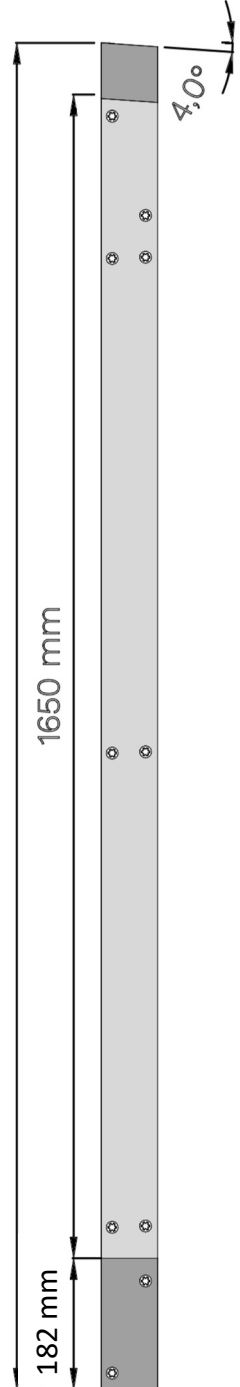

(28*80*182mm)

Plus XL

10.

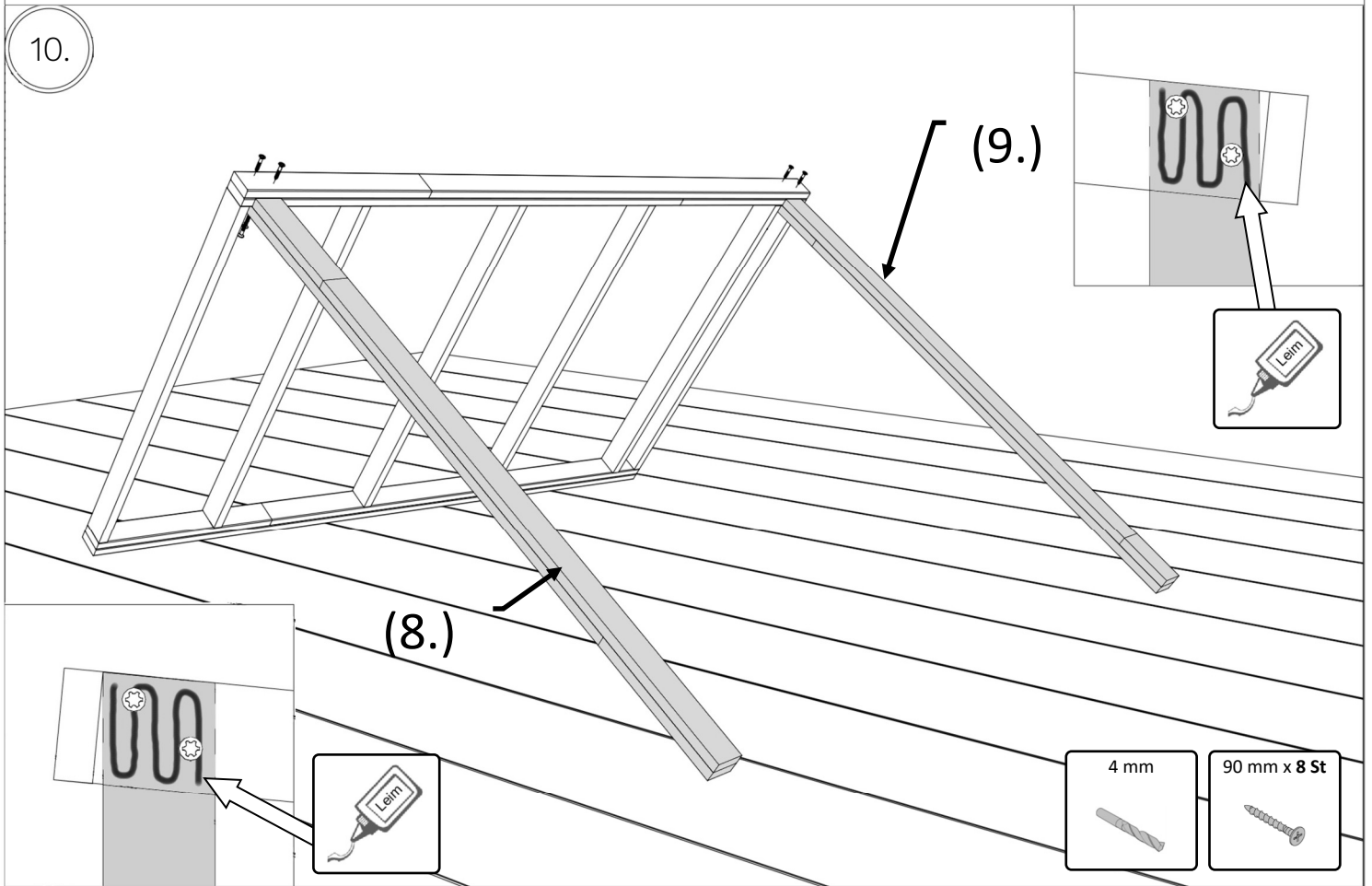

10.1

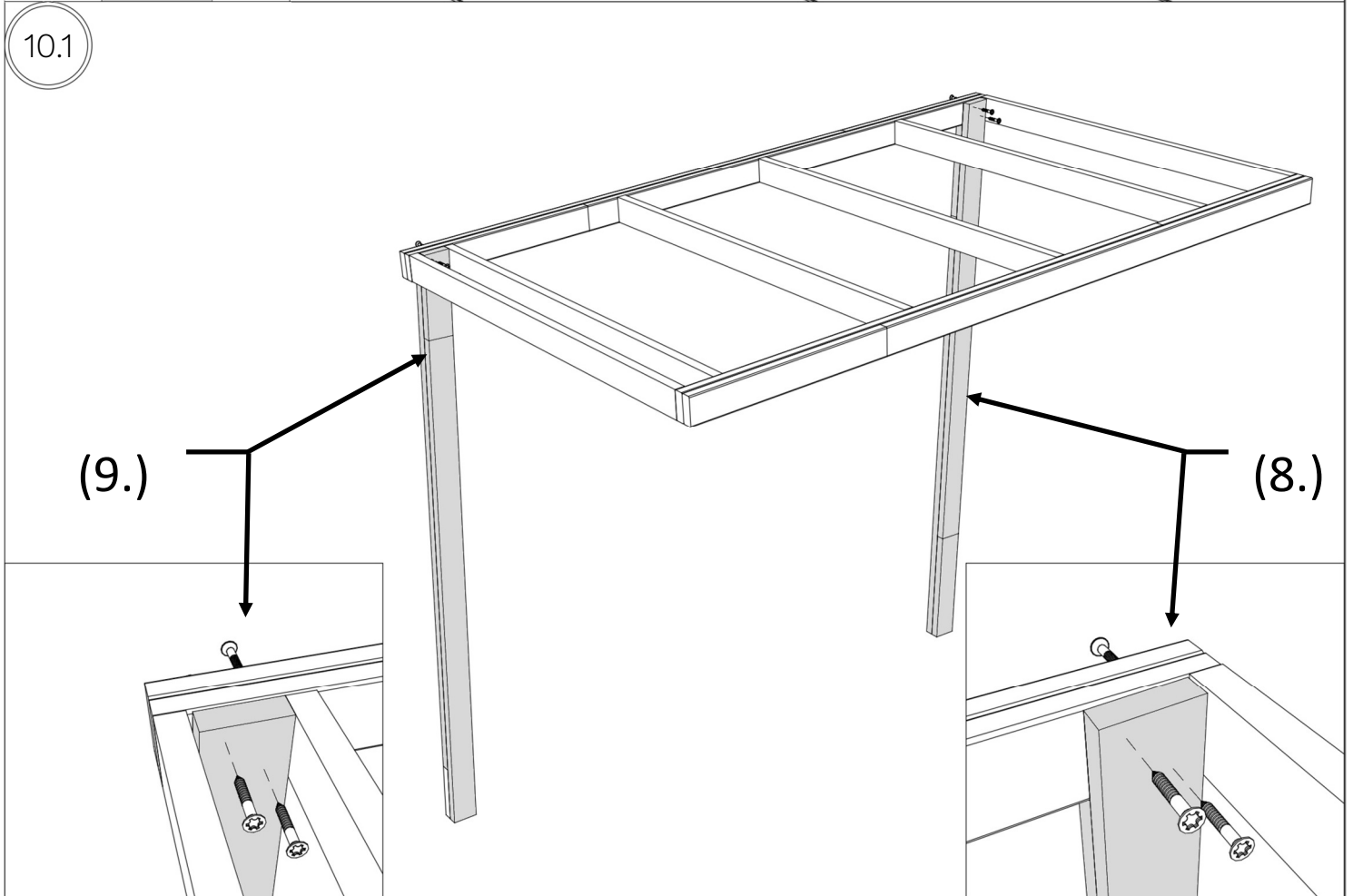

Plus XL

11.

2030 (28*80*840mm)

4 mm

70 mm x 4 St

120 mm x 4 St

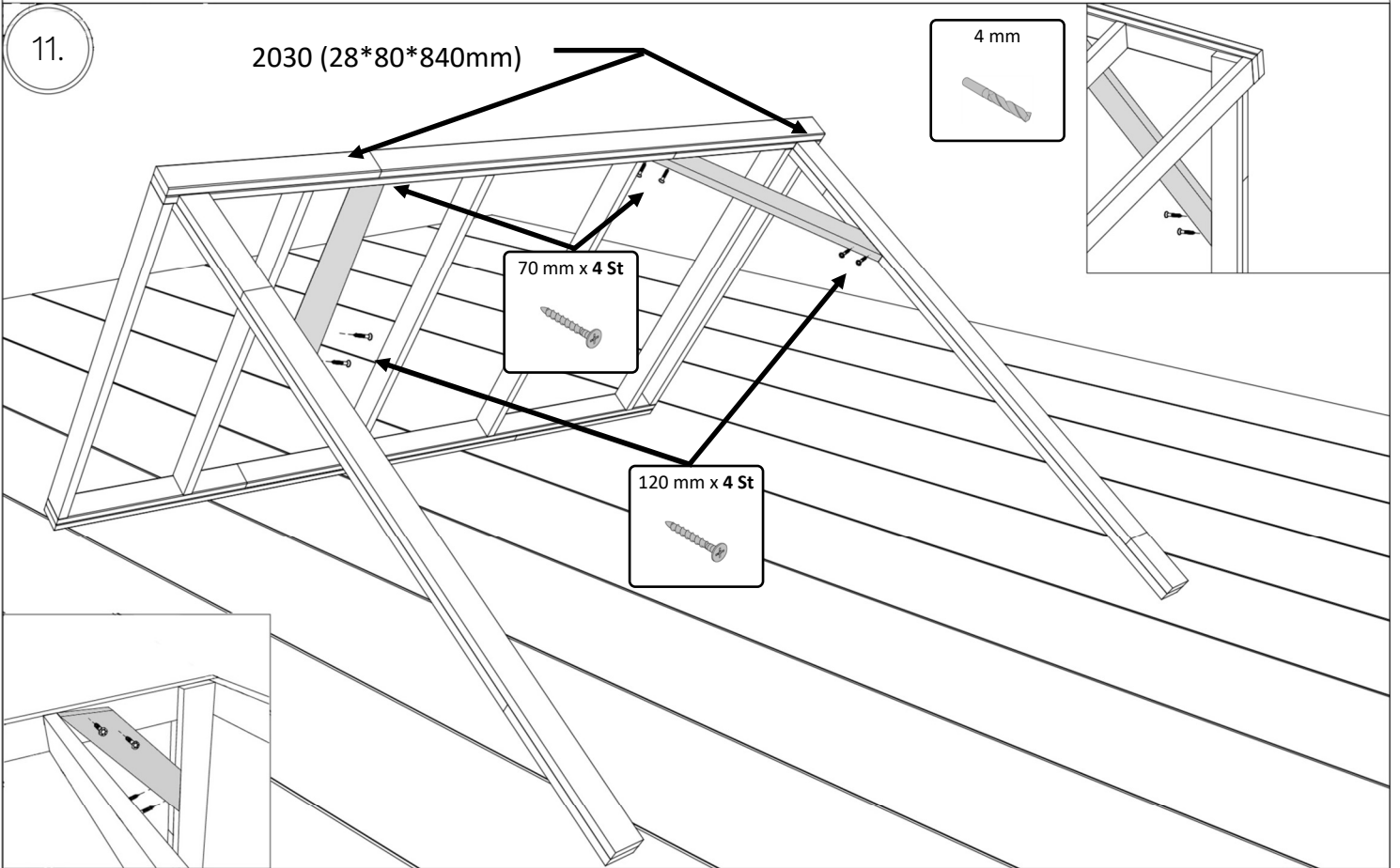

12.

50 mm x 6 St

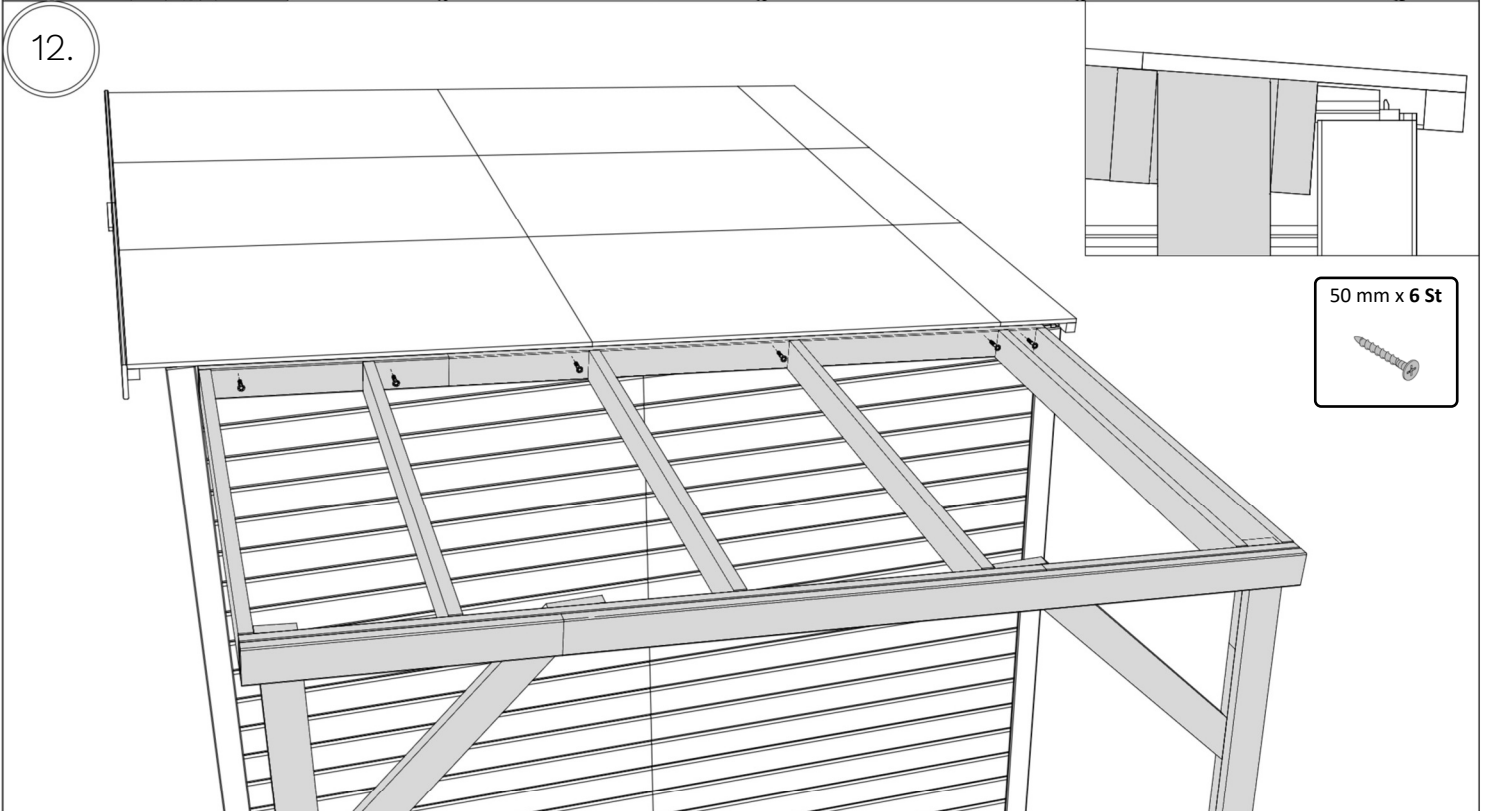

12.1

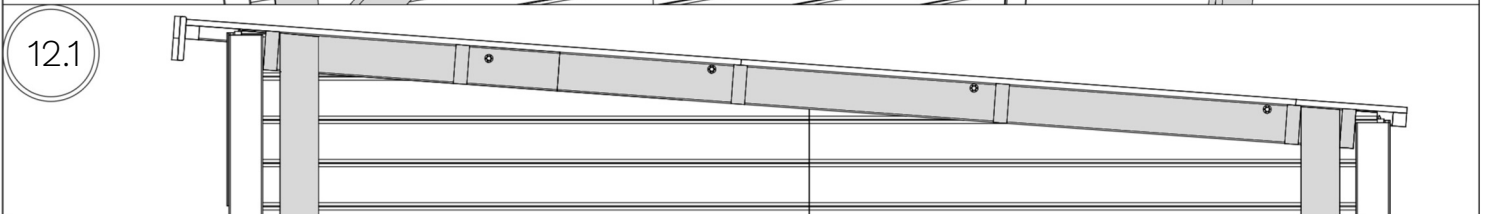

Plus XL

13.

4 mm



50 mm x 6 St

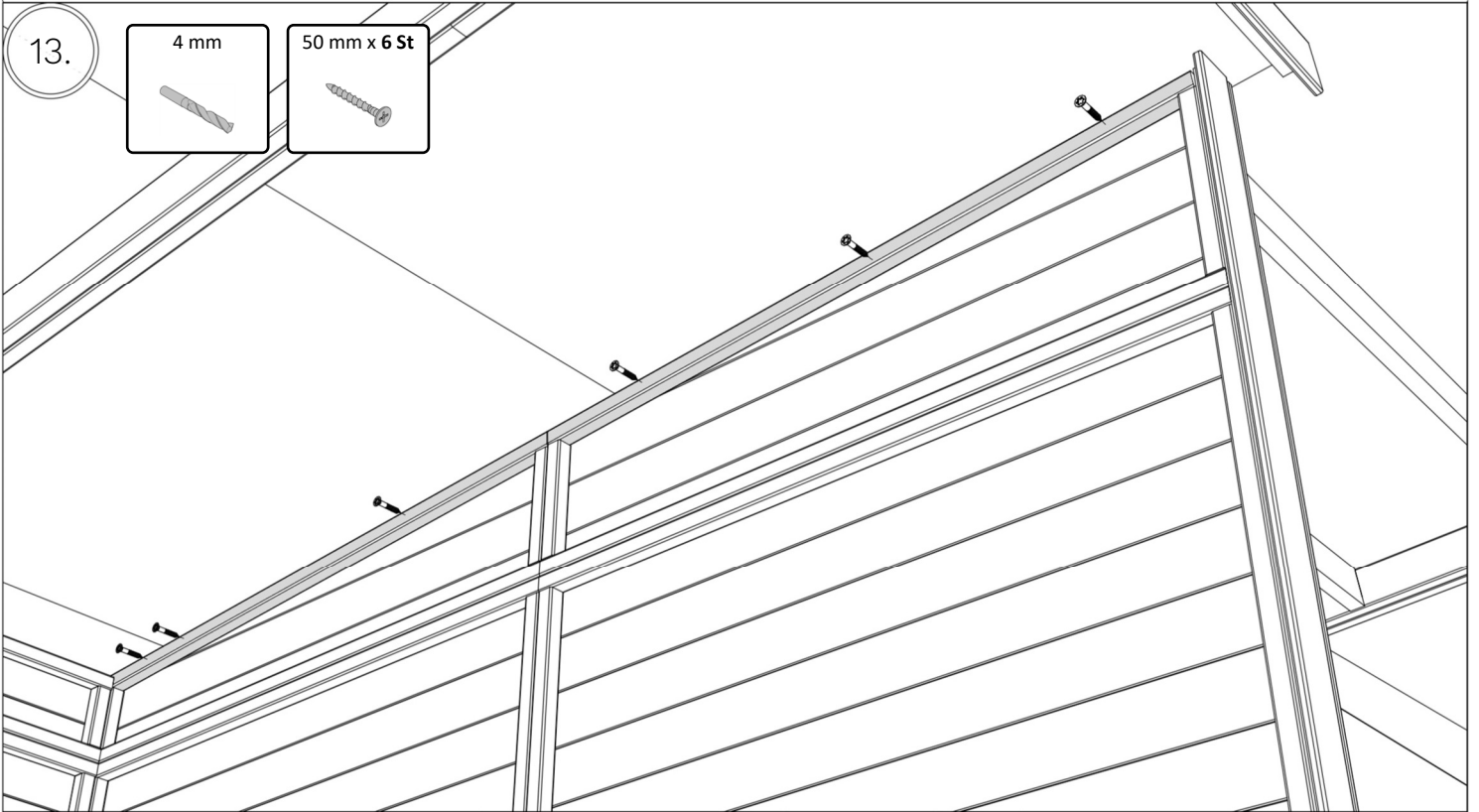

14.

35 mm x 7 St

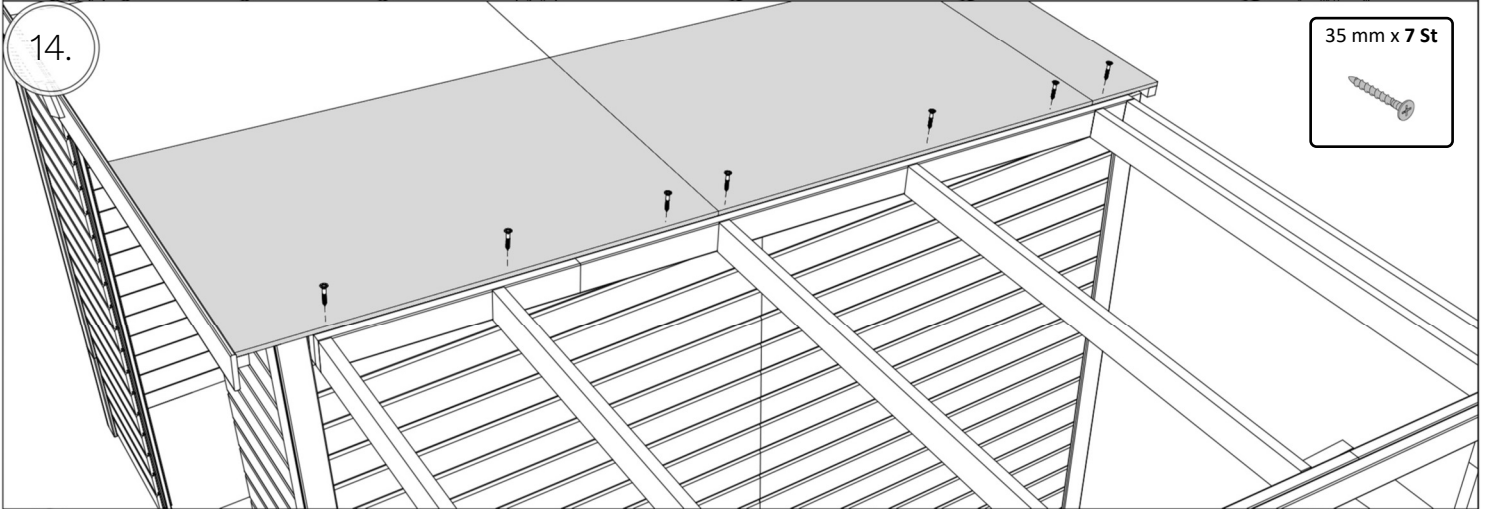

15.

940 (12*595*1150mm)

2023 (12*230*595mm)

35 mm x 10 St

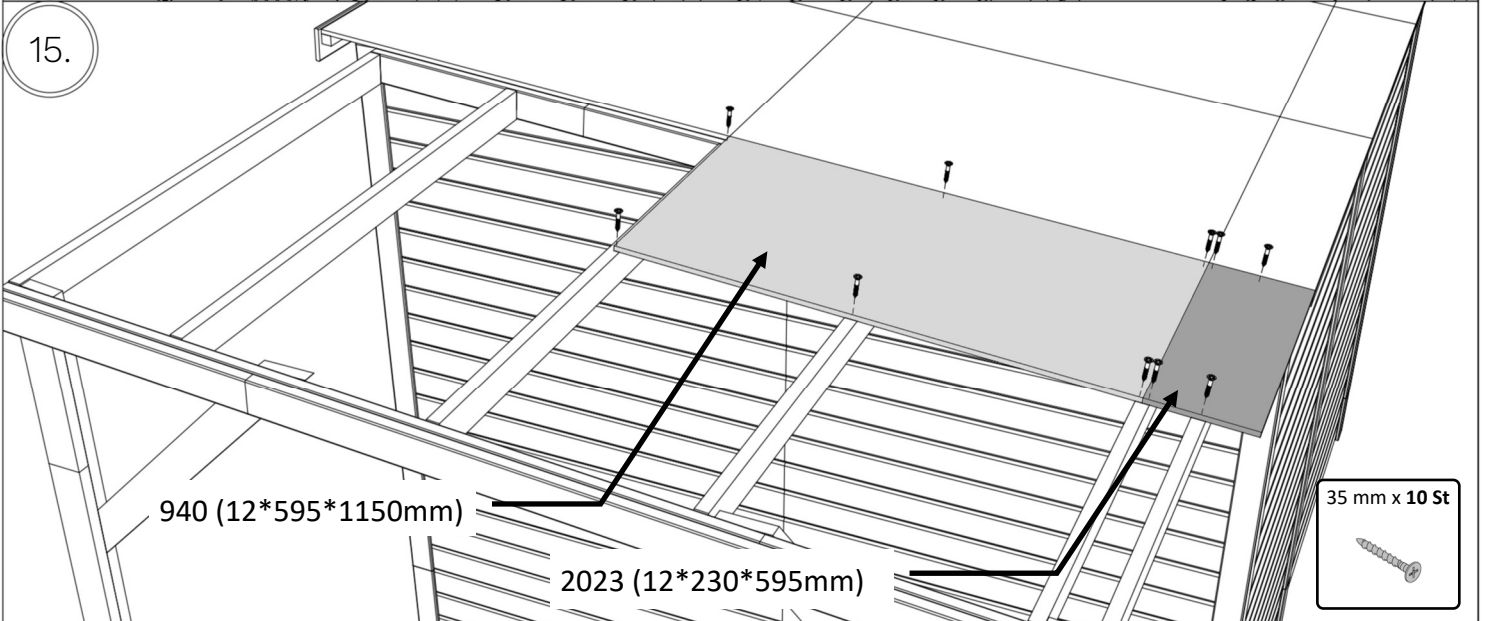

Plus XL

16.

35 mm x 6 St



940 (12*595*1150mm)

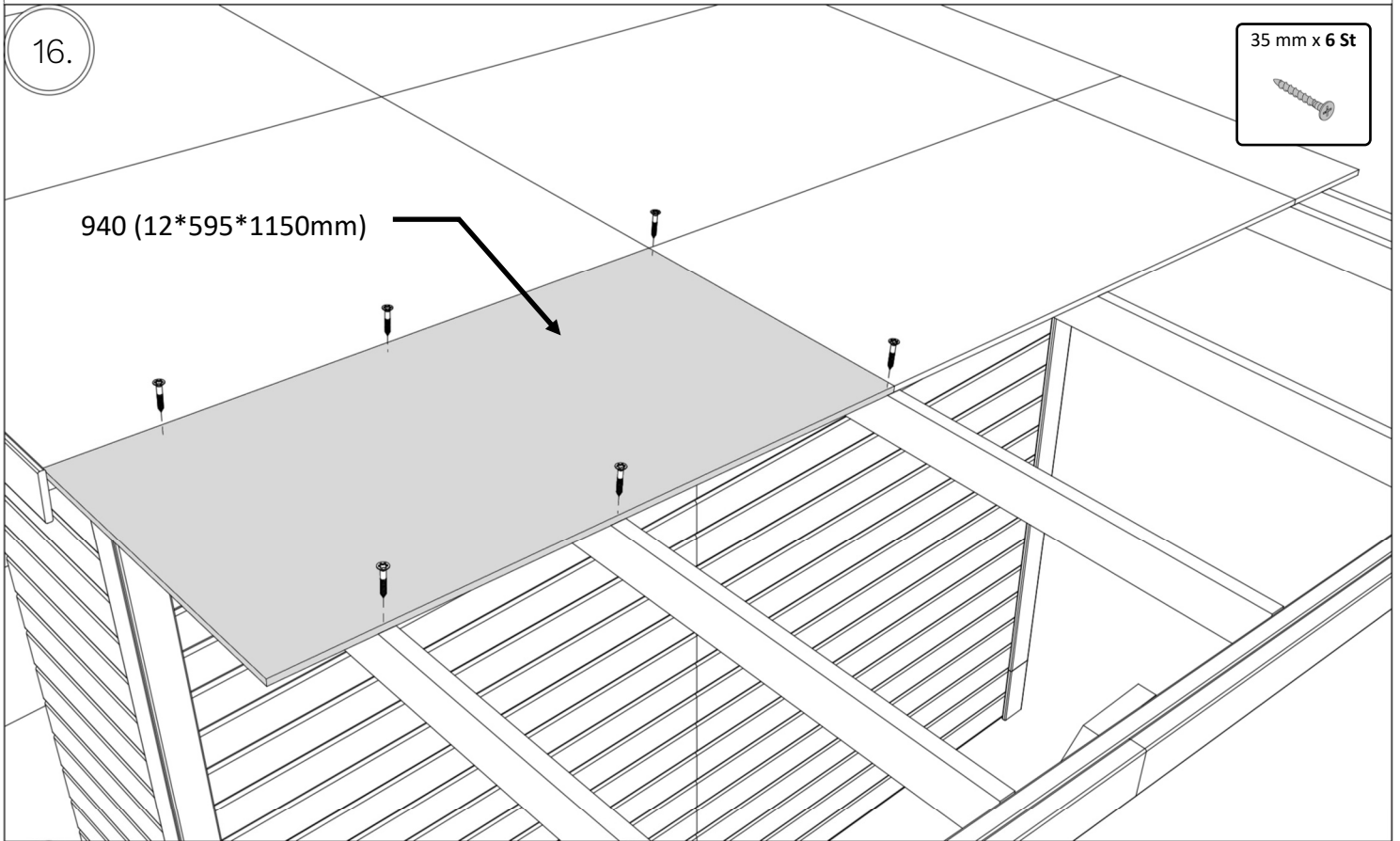

17.

516 (12*830*1150mm)

35 mm x 28 St



678 (12*230*830mm)

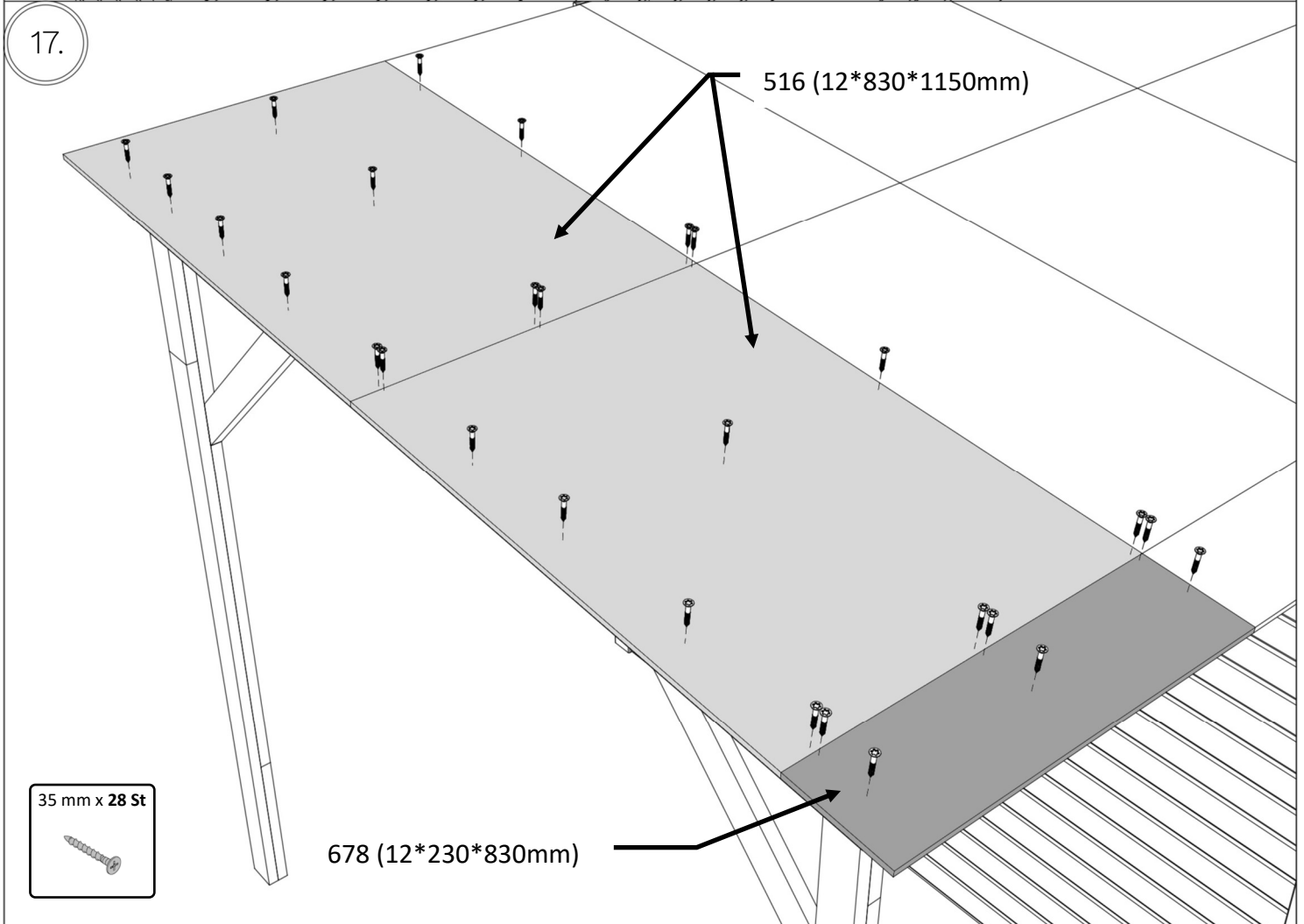

Plus XL

18.

35 mm x 19 St

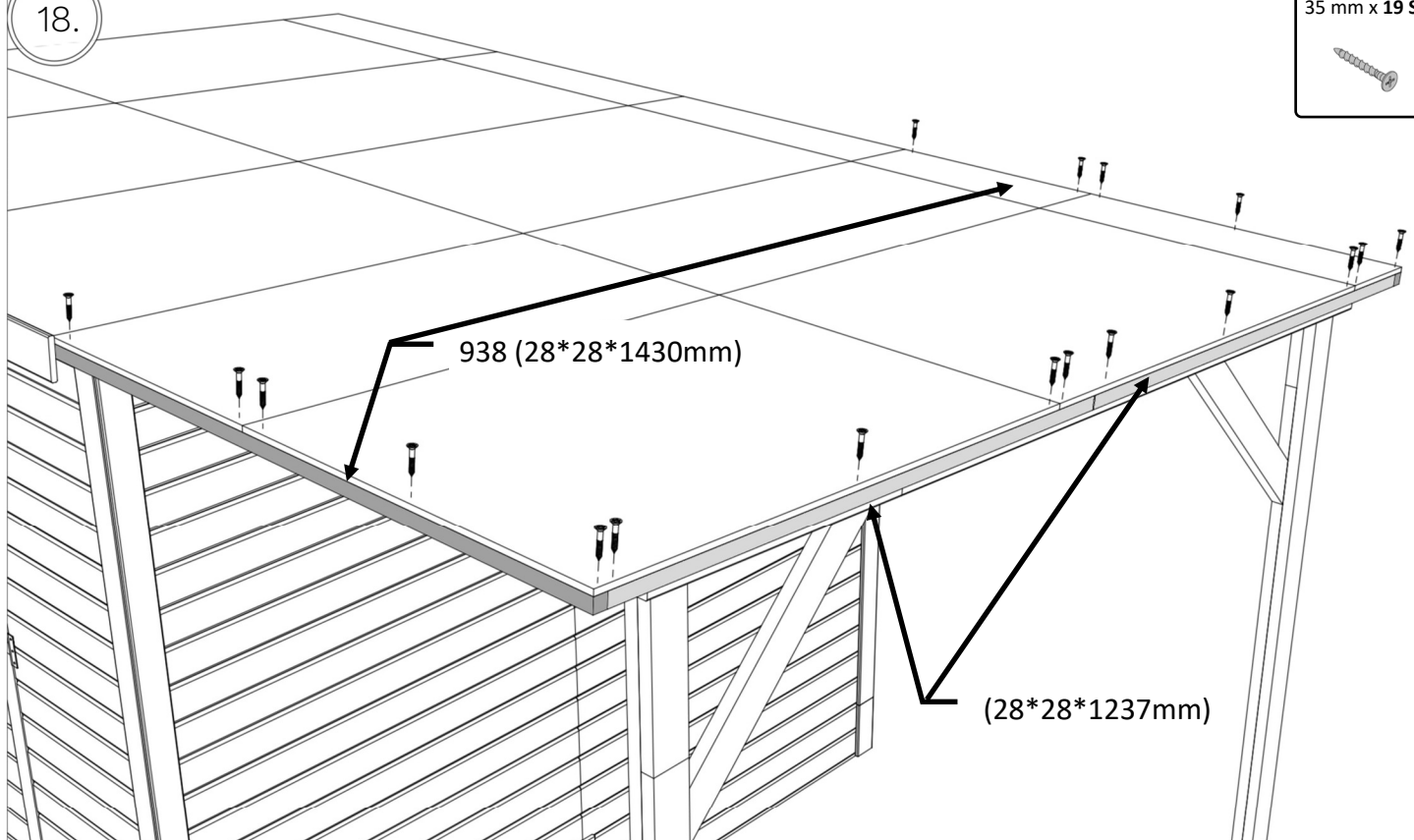

19.

939 (12*90*1430mm)

628

628

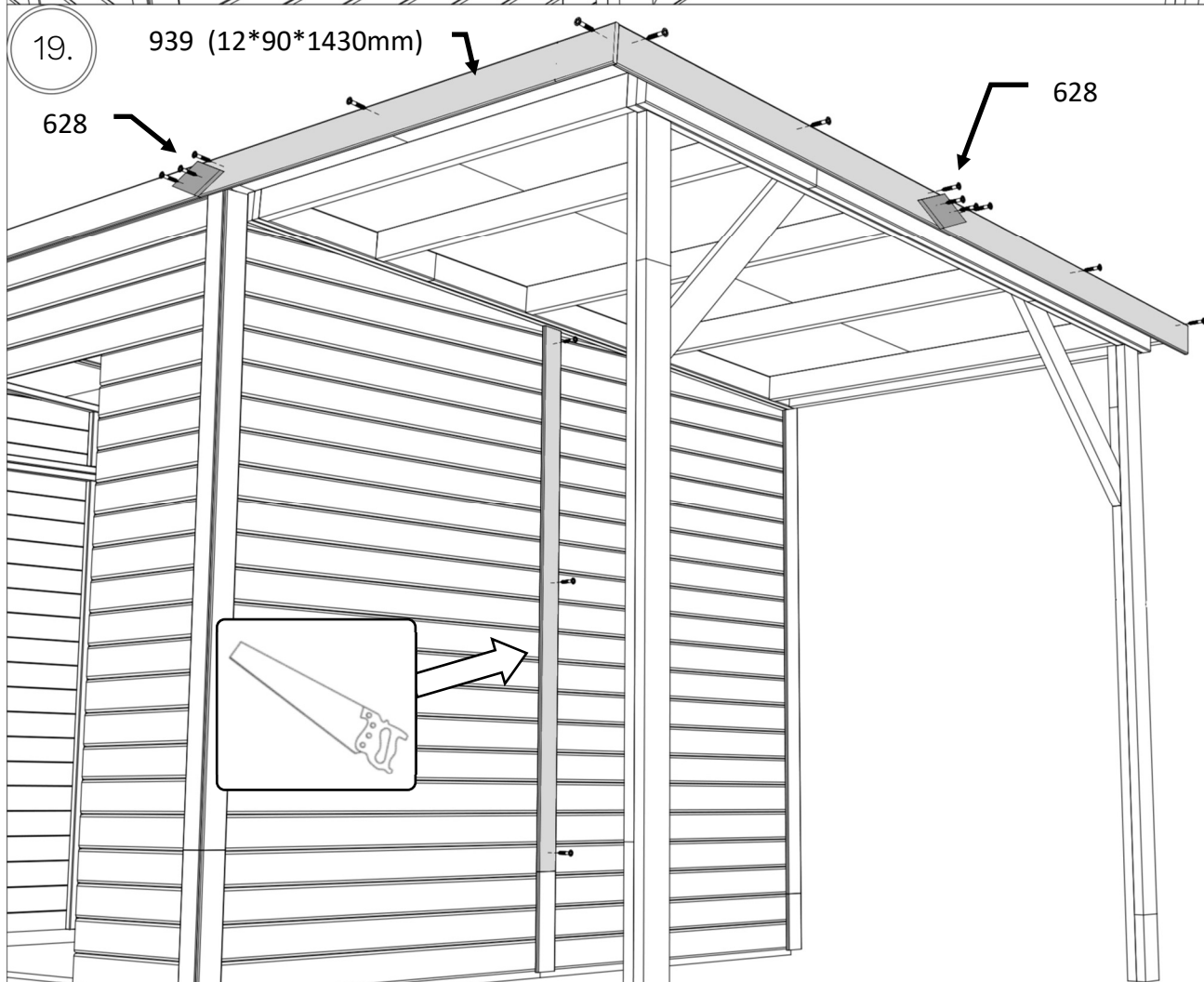

4 mm



35 mm x 16 St



Plus XL

20.

932 (28*80*1650mm)

2031

2031 (28*80*609mm)

4 mm

50 mm x 14 St

2X

21.

710

206

515

586

83

2259

21.1

710

206

515

586

83

2028 (28*80*1286mm)

NB!!!! OTFEL10x8P

4 mm

120 mm x 24 St

22.

1644

1650

410

182

330

252

324

258

1300

932 (painted)

2X

2032

Plus XL

23.

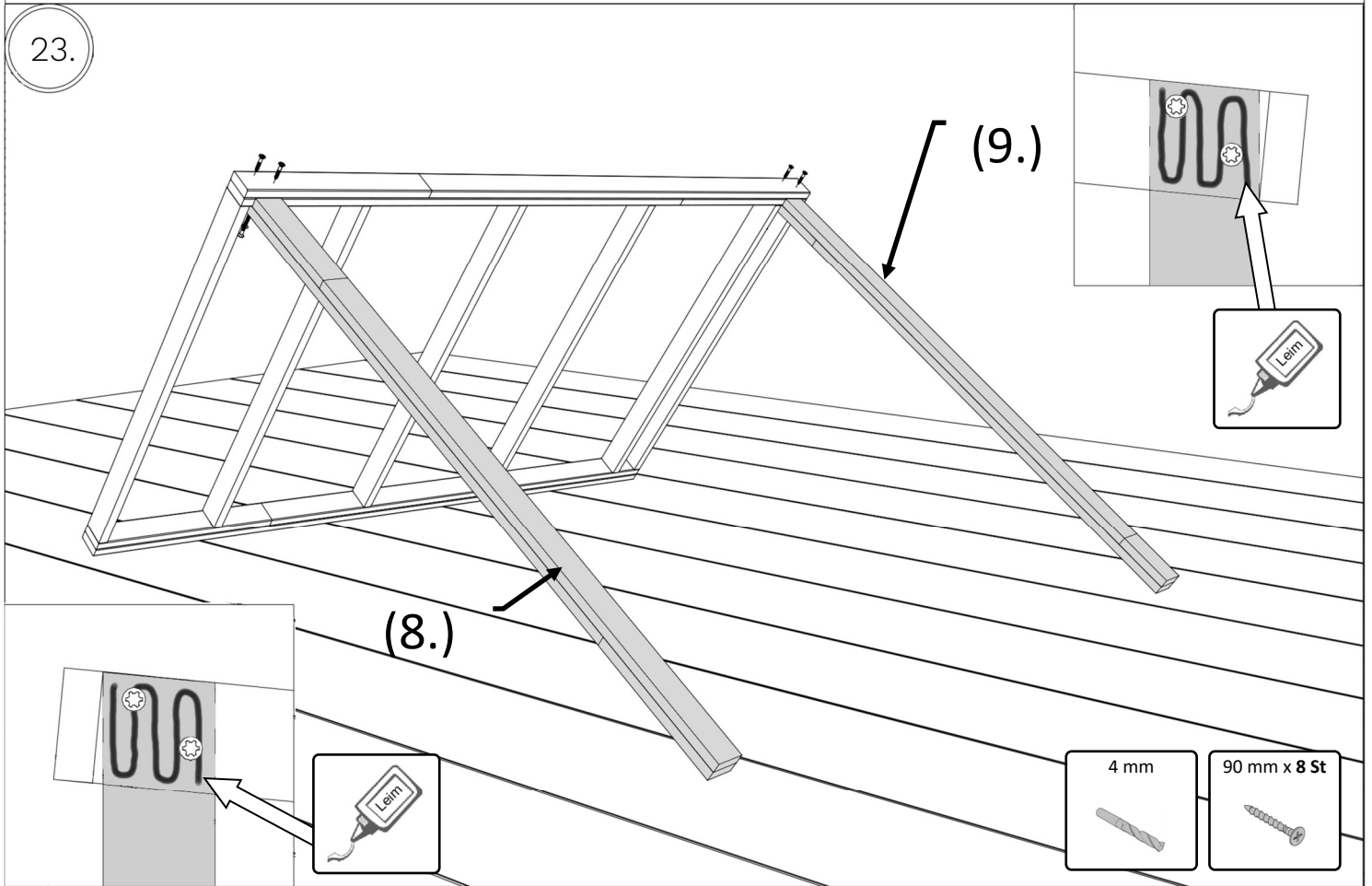

23.1

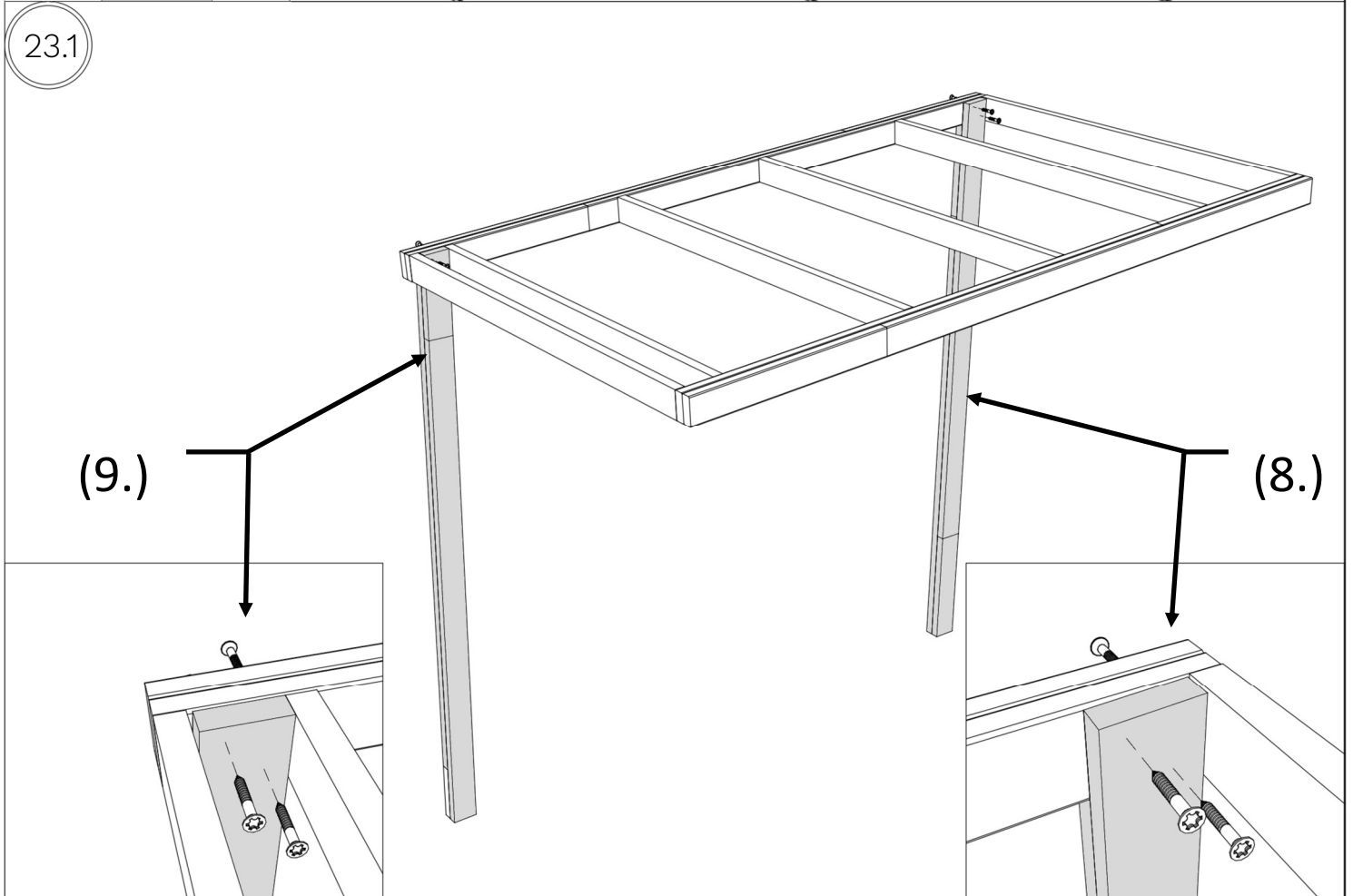

Plus XL

24. 2030 (28*80*840mm)

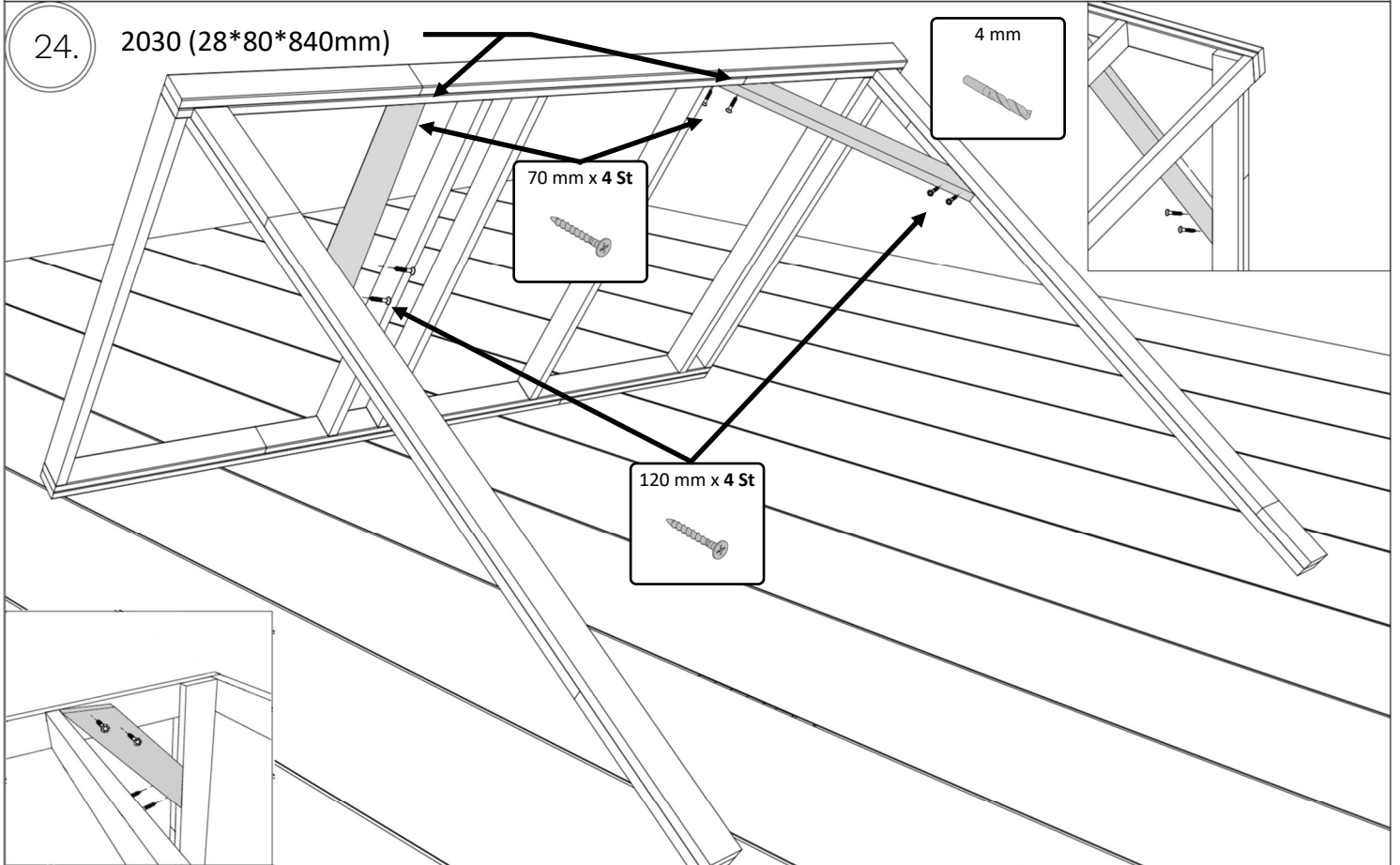

25.

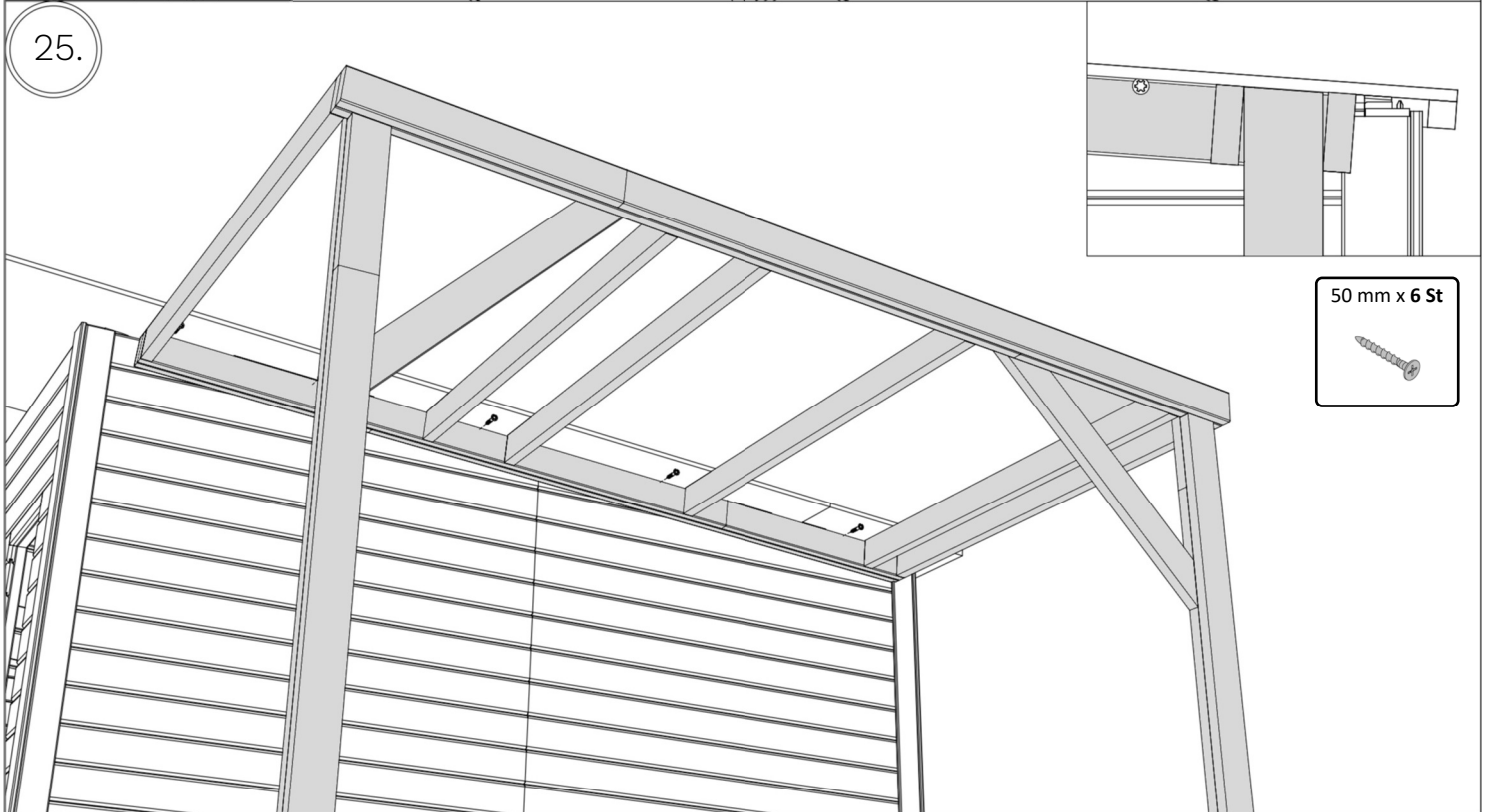

25.1

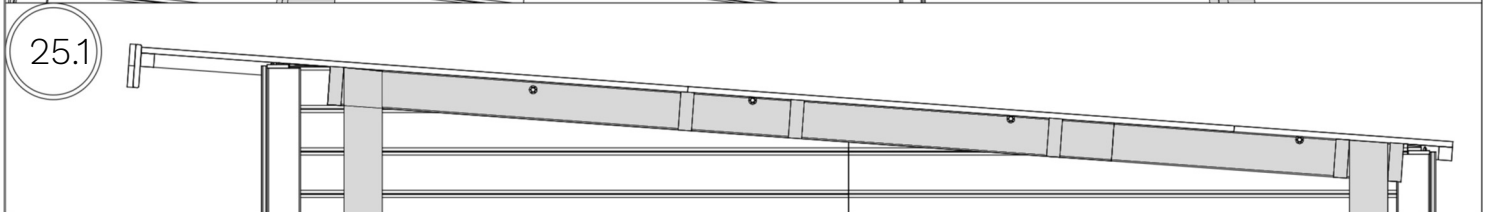

Plus XL

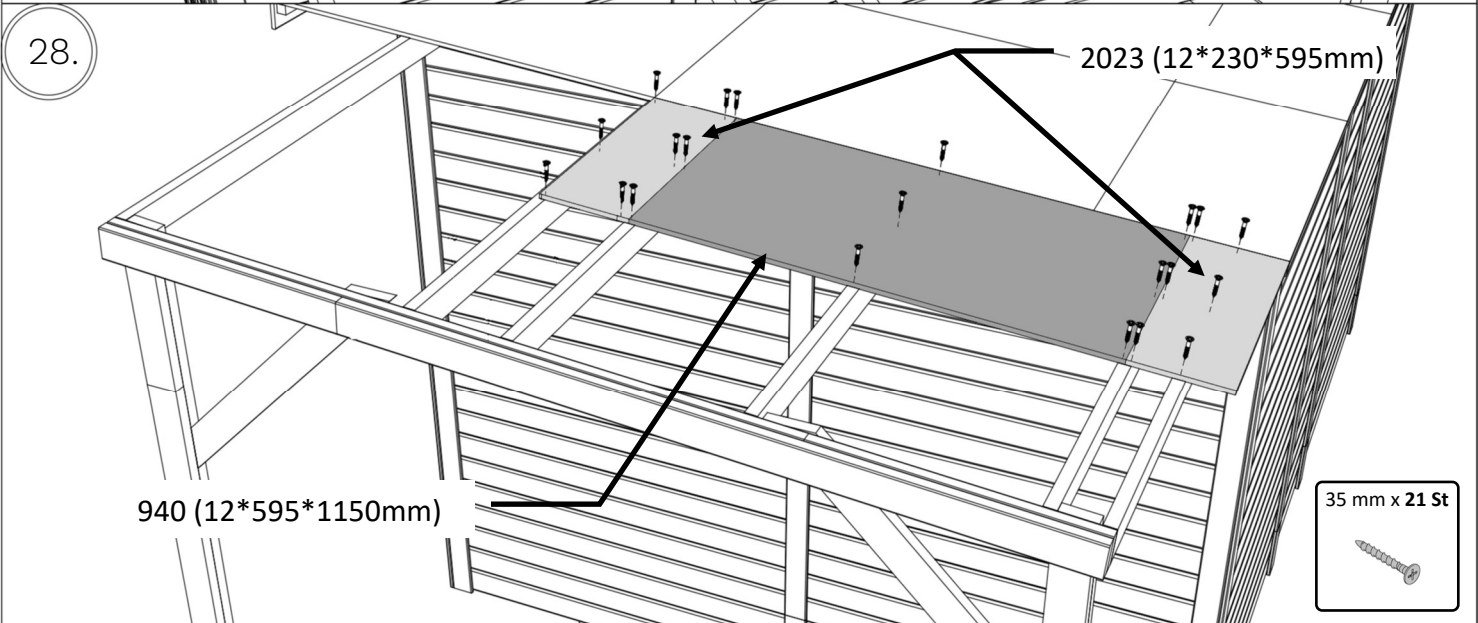
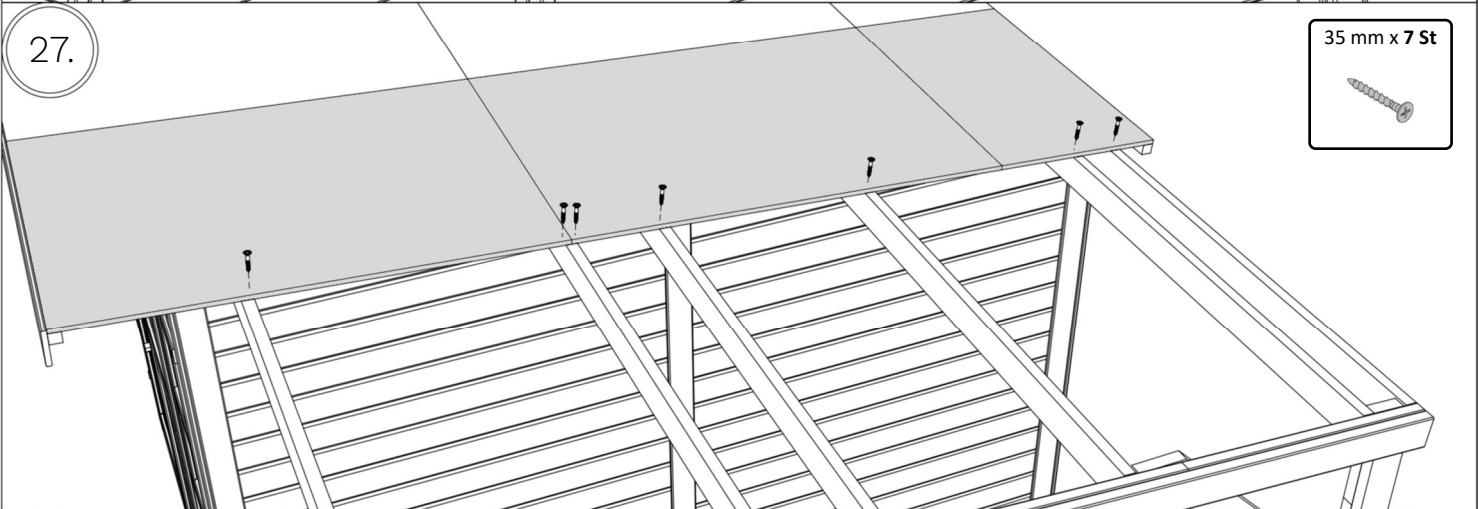
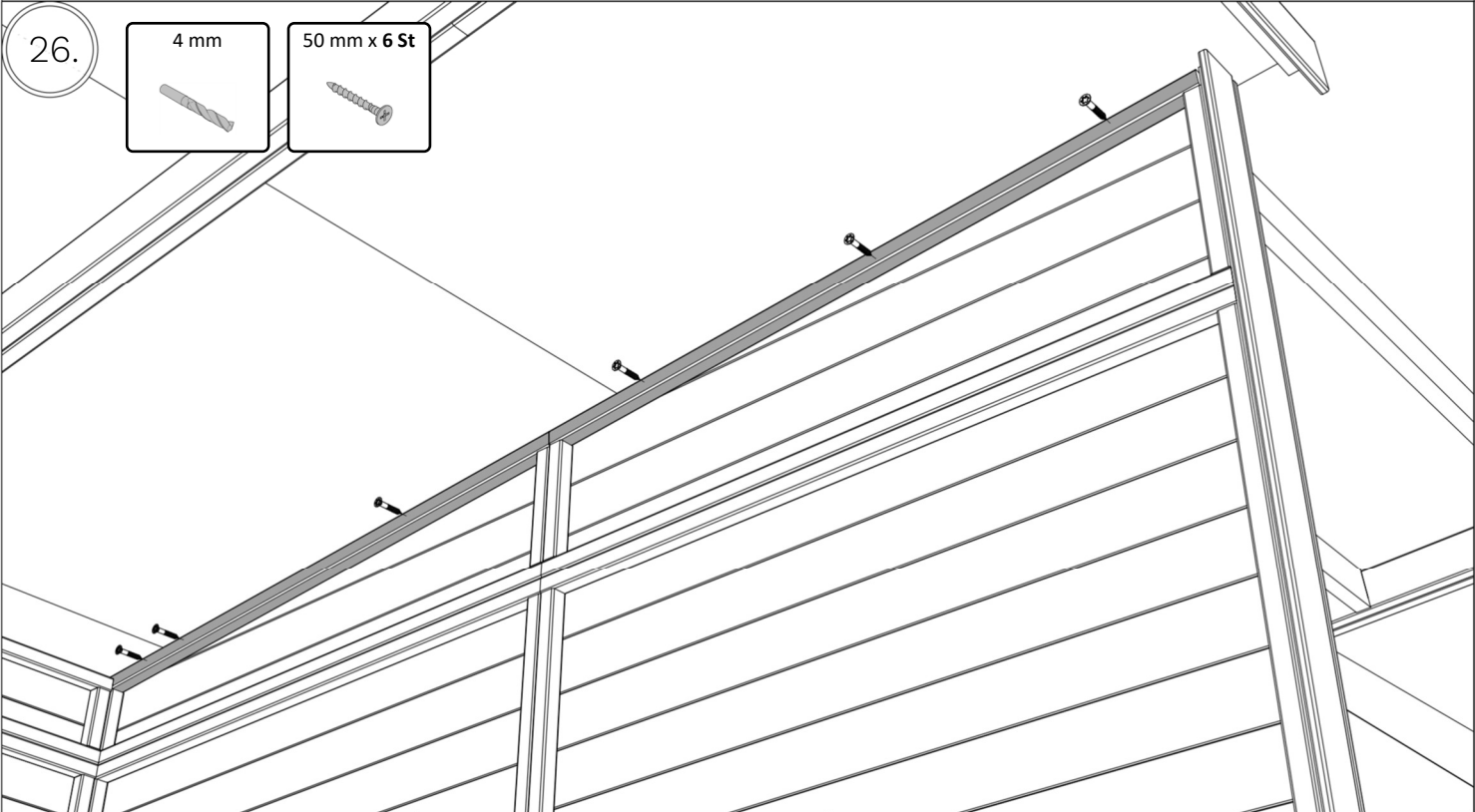

Plus XL

29.

35 mm x 6 St



940 (12*595*1150mm)

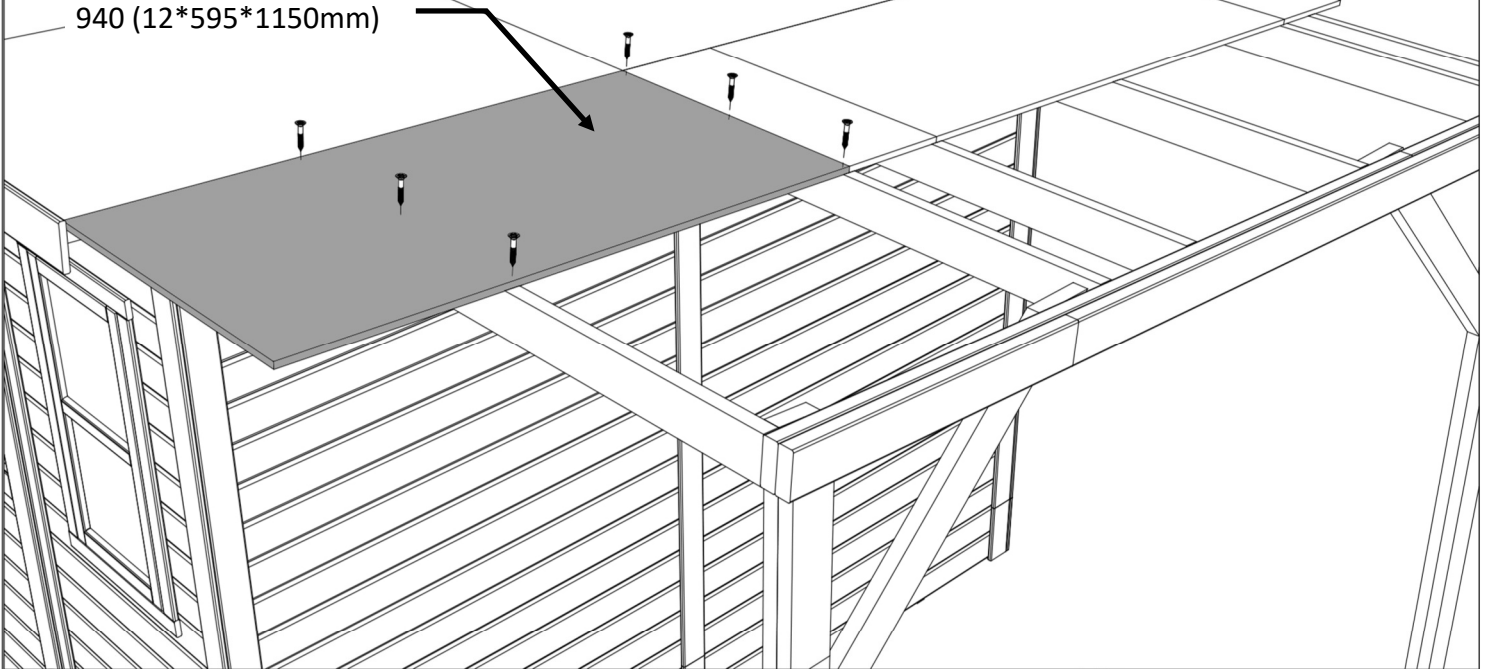

30.

516 (12*830*1150mm)

678 (12*230*830mm)

35 mm x 31 St

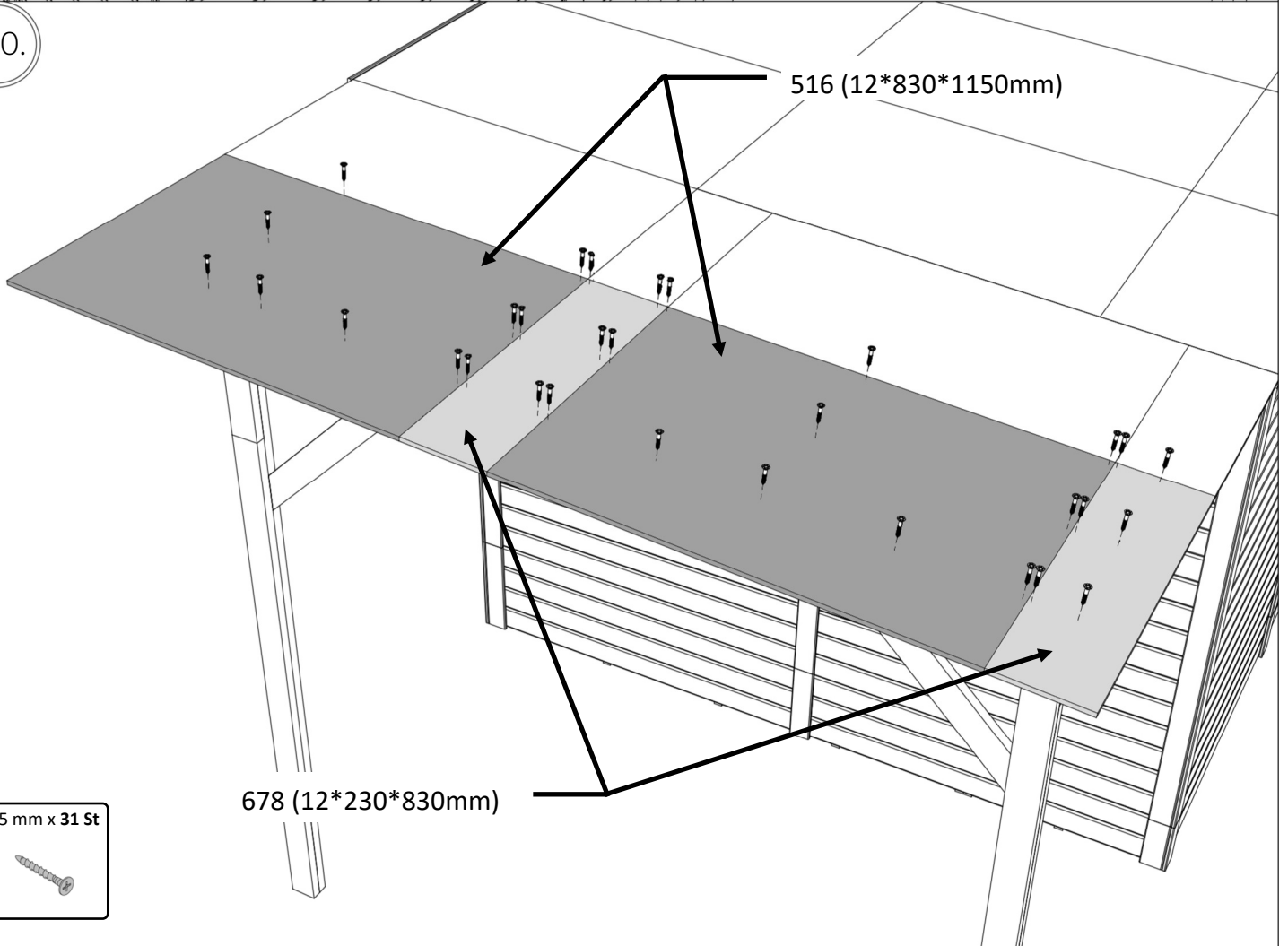

Plus XL

31.

35 mm x 19 St

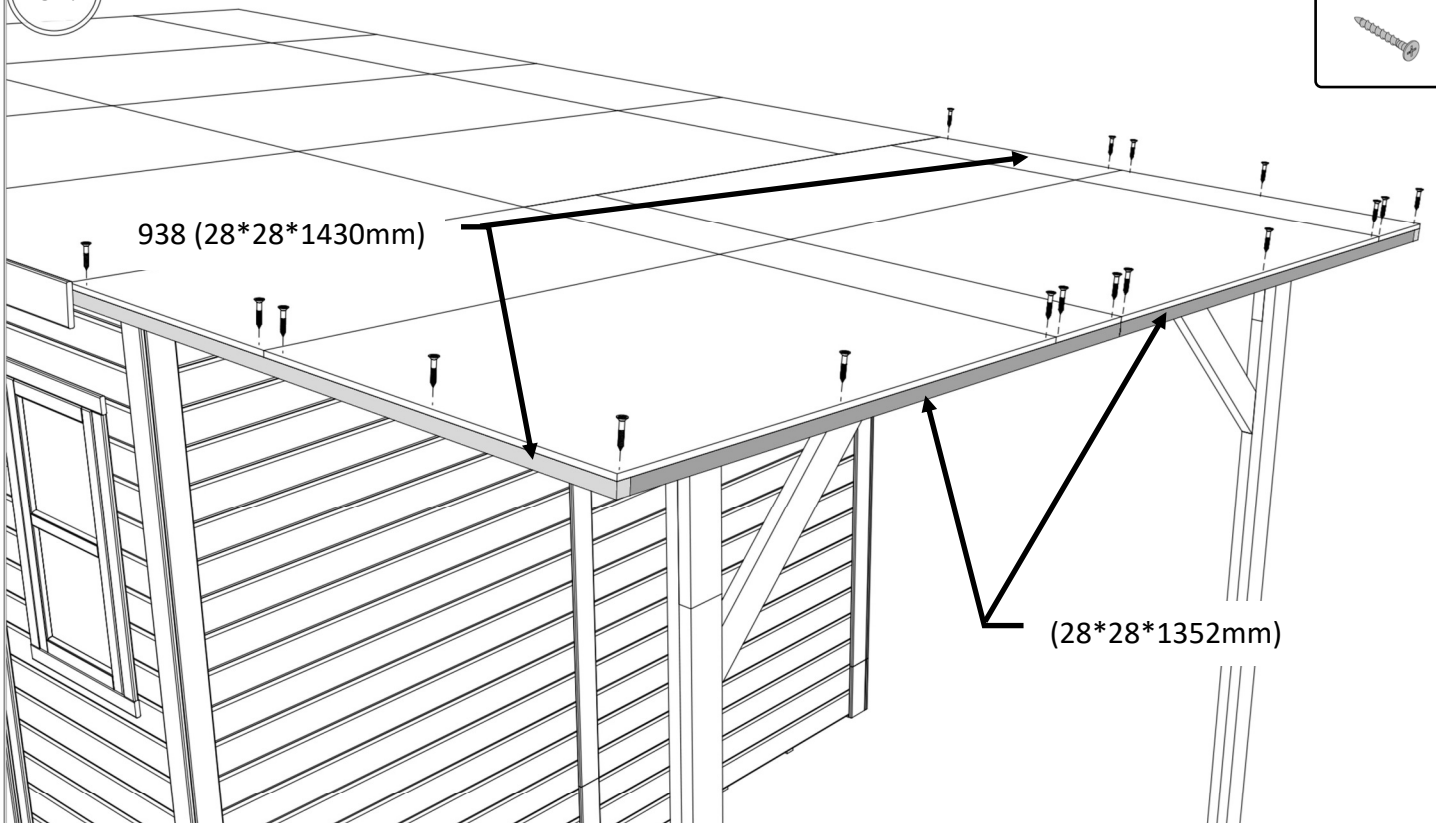

32.

939 (12*90*1430mm)

628

628

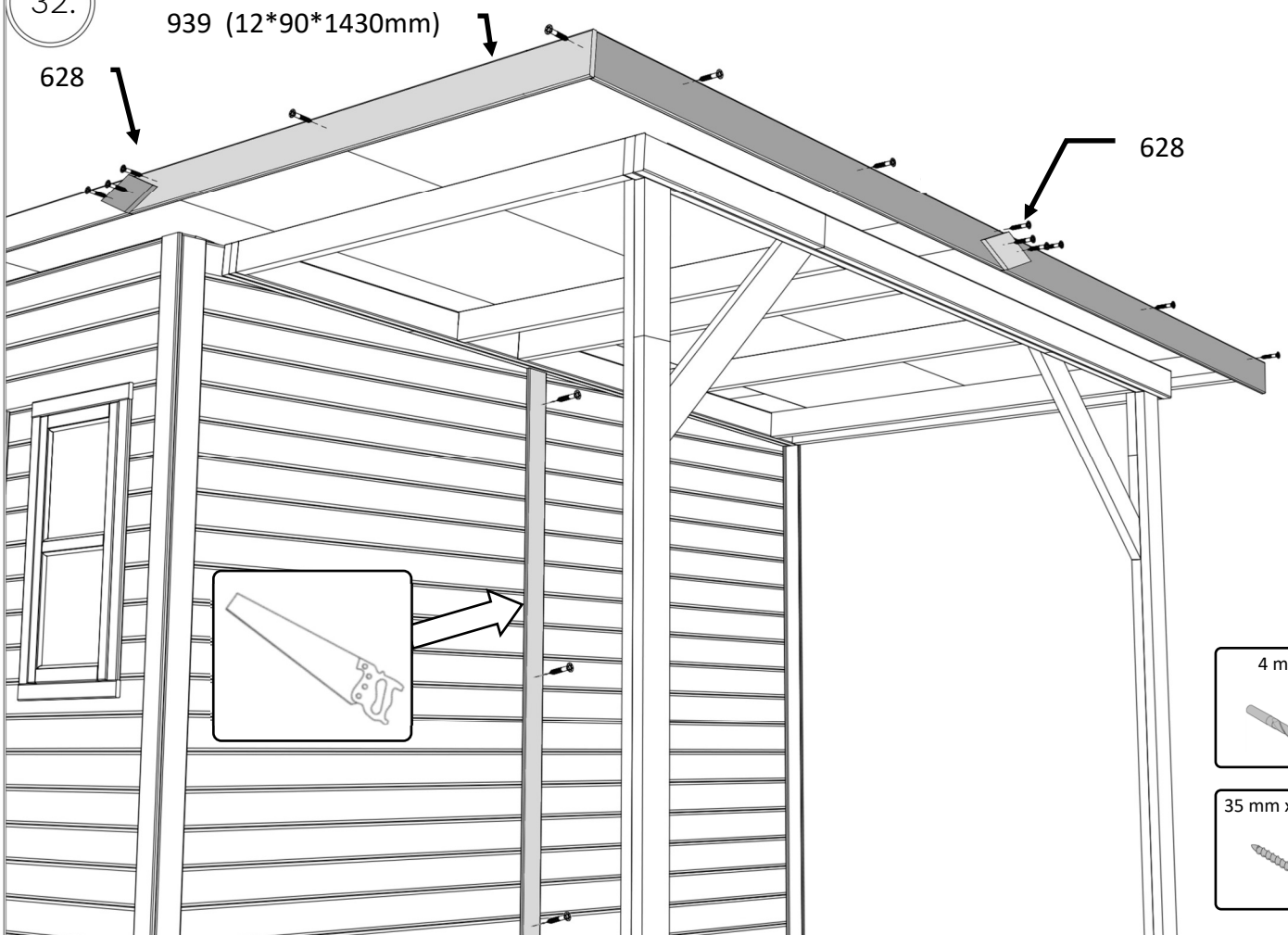

4 mm



35 mm x 16 St

